

Document Title: <b>Description</b>	Function Group: <b>000</b>	Information Type: <b>Service Information</b>	Date: <b>4/28/2026</b>
Profile: <b>P6870D Volvo PID:12841268</b>			

## Description

Showing Selected Profile

Valid for serial numbers			
Model	Production site	Serial number start	Serial number stop
P6870D Volvo PID:12841268			

The machine is designed for application of all types of graded asphalt aggregates, hydraulically bonded graded aggregates, graded ballast, sand or gravel.

The engine is a six-cylinder, four-stroke, in-line diesel engine with direct injection and water cooling.

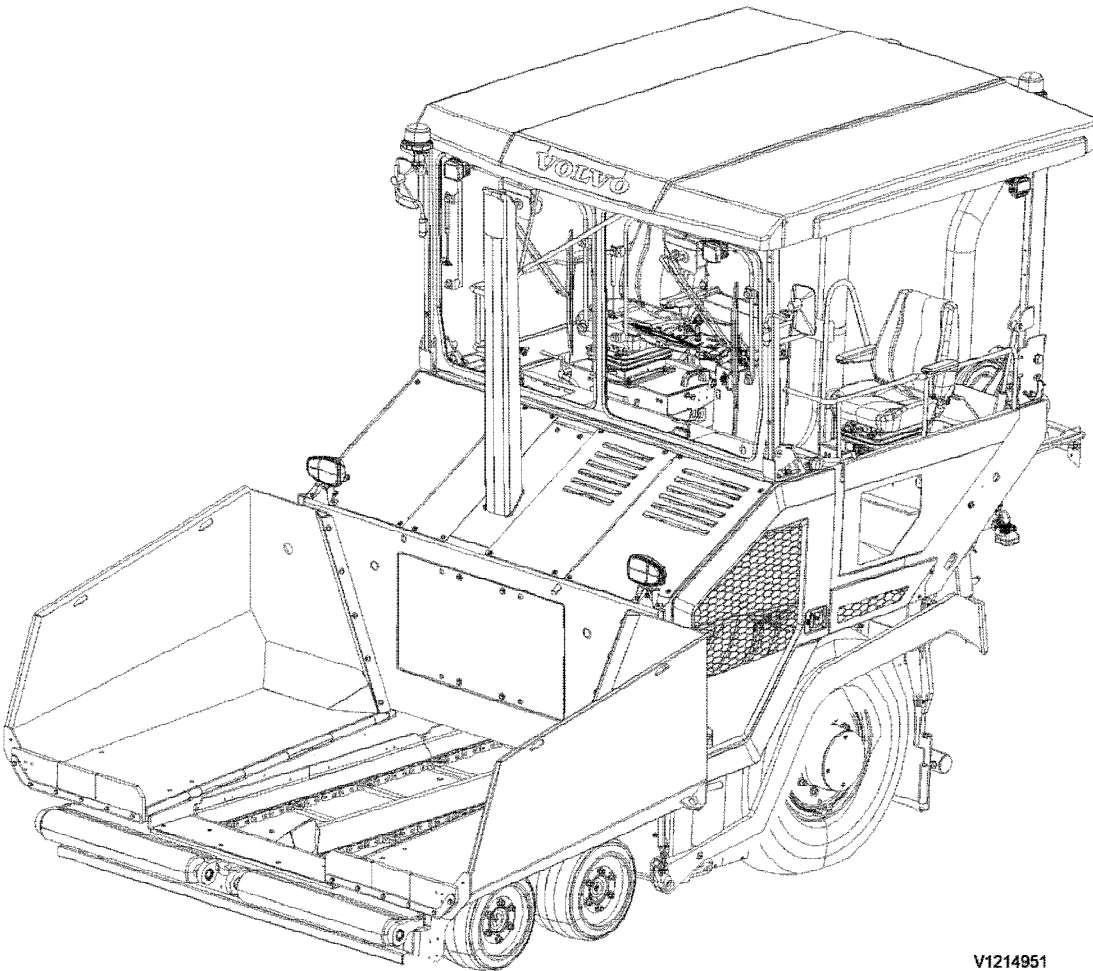

V1214951

**Figure 1**  
General View

Document Title: <b>Standard tightening torques</b>	Function Group: <b>030</b>	Information Type: <b>Service Information</b>	Date: <b>4/28/2026</b>
Profile: <b>P6870D Volvo PID:12841268</b>			

## Standard tightening torques

Showing Selected Profile

Valid for serial numbers			
Model	Production site	Serial number start	Serial number stop
P6870D Volvo PID:12841268			

Tightening torques in the following tables refer to bolted joints with tensile strength according to the below. The tables should be regarded as general guidelines for tightening bolted joints where nothing else is specified.

**NOTE!**

Increase the values by 10% for flange bolt type U6FS. Bolts and nuts should be clean and lubricated with oil.

Surface coating		Coefficient of friction	
Non-electrolytic zinc plate coatings	ISO10683-FLZN/ZN/TL/480	0.08	
	ISO10683-FLZN/ZN/TL/720		
	(ISO10683) Geomet 500A		
Yellowish iridescent	ISO4042-A2C	0.12	
Electrolytic coating	ASTMF 1941 Fe/Zn5ANS	0.24	

Dimension s	Strength classes	Coefficient of friction					
		0.08		0.12		0.24	
		Tightening torque (Nm)	Tightening torques: (lbf ft)	Tightening torque (Nm)	Tightening torques: (lbf ft)	Tightening torque (Nm)	Tightening torques: (lbf ft)
M4	8.8	2.3	1.7	3	2.21	3.8	2.8
	10.9	3.3	2.43	4.6	3.39	5.5	4.06
	12.9	3.9	2.87	5.1	3.76	6.5	4.79
M5	8.8	4.4	3.24	5.9	4.35	7.5	5.53
	10.9	6.5	4.79	8.6	6.34	11	8.11
	12.9	7.6	5.61	10	7.37	12.9	9.51
M6	8.8	7.7	5.67	10.1	7.44	13	9.59
	10.9	11.3	8.33	14.9	10.98	19.1	14.09
	12.9	13.2	9.73	17.4	12.83	22.3	16.45
M7	8.8	12.6	9.29	16.8	12.39	21.8	16.08
	10.9	18.5	13.64	24.7	18.21	32	23.6
	12.9	21.6	15.93	28.9	21.31	37.5	27.66
M8	8.8	18.5	13.64	24.6	18.14	31.7	23.38
	10.9	27.2	20.06	36.1	26.62	46.4	34.22
	12.9	31.8	23.45	42.2	31.12	54.4	40.12
M10	8.8	36	26.55	48	35.4	62.8	46.32
	10.9	53	39.09	71	52.36	92.3	68.08

Sample manual. Download All 2298 pages at:

<https://www.arepairmanual.com/downloads/p6870d-volvo-wheeled-pavers-service-manual/>

M12	12.9	62	45.72	83	61.21	107	78.92
	8.8	63	46.46	84	61.95	108	79.66
	10.9	92	67.85	123	90.72	158.8	117.12
	12.9	108	79.65	144	106.20	185.5	136.82
M14	8.8	100	73.75	133	98.09	172.6	127.3
	10.9	146	107.68	195	143.82	252.9	186.53
	12.9	171	126.12	229	168.90	296.3	218.54
M16	8.8	153	112.84	206	151.93	268.6	198.11
	10.9	224	165.21	302	222.74	395.1	291.41
	12.9	262	193.24	354	261.09	462.5	341.12
M18	8.8	220	162.26	295	217.58	383.1	282.56
	10.9	314	231.59	421	310.51	546.5	403.08
	12.9	367	270.68	492	362.88	638.8	471.15
M20	8.8	308	227.16	415	306.08	542.8	400.35
	10.9	438	323.05	592	436.63	773.5	570.5
	12.9	513	378.36	692	510.39	904.6	667.2
M22	8.8	417	307.56	567	418.19	745.8	550.07
	10.9	595	438.84	807	595.21	1062.5	783.66
	12.9	696	513.34	945	696.99	1243.4	917.08
M24	8.8	529	390.17	714	526.61	933.2	688.29
	10.9	754	556.12	1017	750.1	1329.2	980.37
	12.9	882	650.52	1190	877.69	1555.4	1147.2
M27	8.8	772	569.39	1050	774.44	1382.8	1019.9
	10.9	1100	811.31	1496	1103.39	1969.8	1452.85
	12.9	1287	949.24	1750	1290.73	2304.9	1700
M30	8.8	1053	776.65	1428	1053.23	2090.8	1542.09
	10.9	1500	1106.34	2033	1499.46	2670.5	1969.66
	12.9	1755	1294.42	2380	1755.39	3125.5	2305.25

UNC threads, coarse pitch	Nm	lbf ft
1/4"	9 ±2	6.6 ±1.5
5/16"	18 ±4	13 ±3.0
3/8"	33 ±8	24 ±5.9
7/16"	54 ±14	40 ±10
1/2"	80 ±20	59 ±15
9/16"	120 ±30	89 ±22
5/8"	170 ±40	130 ±30
3/4"	300 ±70	220 ±52
7/8"	485 ±115	360 ±85
1"	725 ±175	530 ±130

Document Title: <b>Component locations</b>	Function Group: <b>030</b>	Information Type: <b>Service Information</b>	Date: <b>4/28/2026</b>
Profile: <b>P6870D Volvo PID:12841268</b>			

## Component location

Showing Selected Profile

Valid for serial numbers			
Model	Production site	Serial number start	Serial number stop
P6870D Volvo PID:12841268			

### Main components

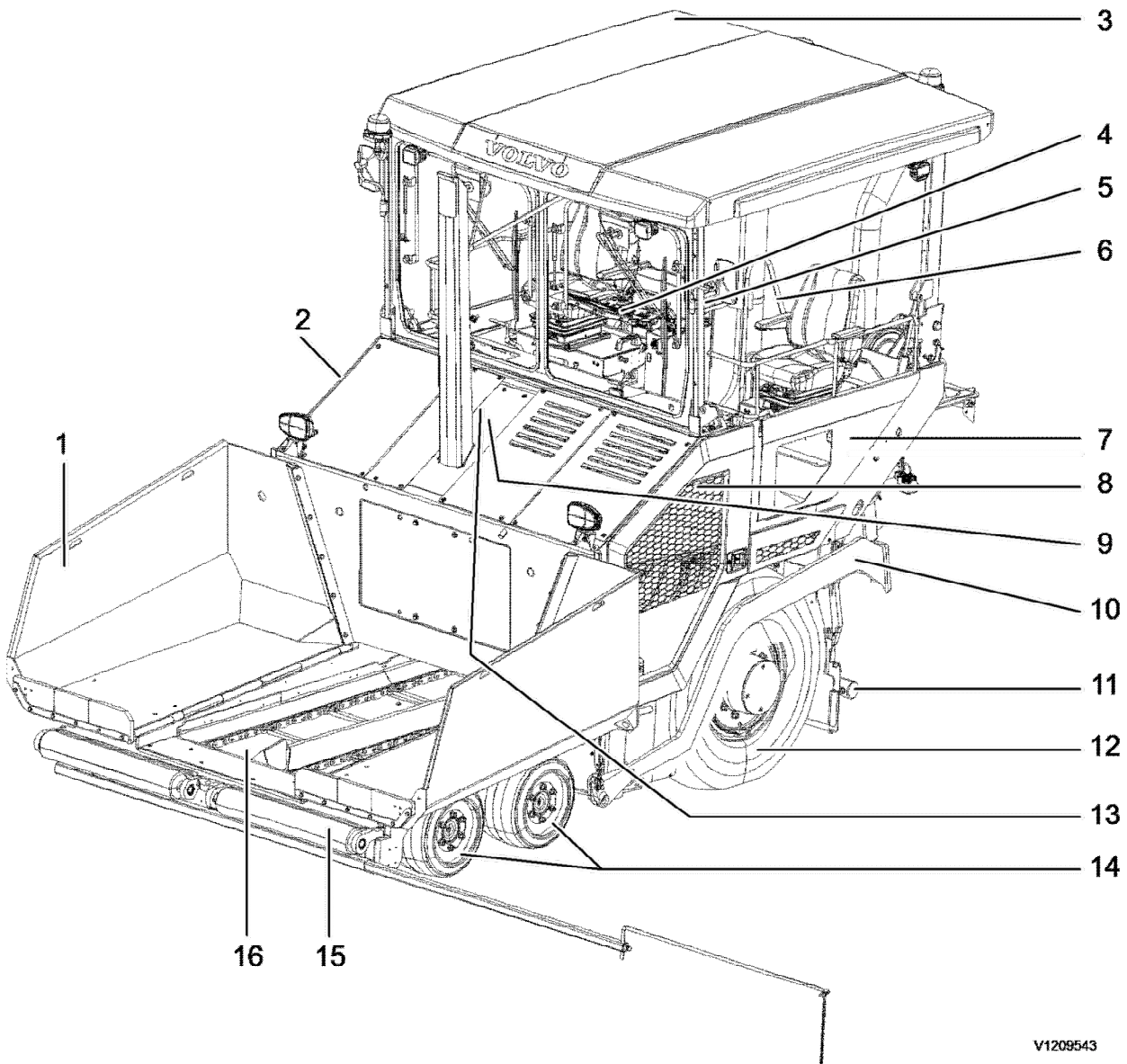

V1209543

**Figure 1**  
Main components

Position	Description	Position	Description	Position	Description
1	Hopper	7	Fold-out operator's platform	13	Exhaust aftertreatment system
2	Radiator	8	Hydraulic oil tank	14	Front wheels
3	All-weather roof	9	Engine Pump gearbox	15	Oscillating beam with push rollers and direction indicator
4	Paving panel and driving panel	10	Towing arm	16	Conveyor
5	Switch cabinet screed heating	11	Auger		
6	Ladder	12	Rear wheel		

### Maintenance hatches

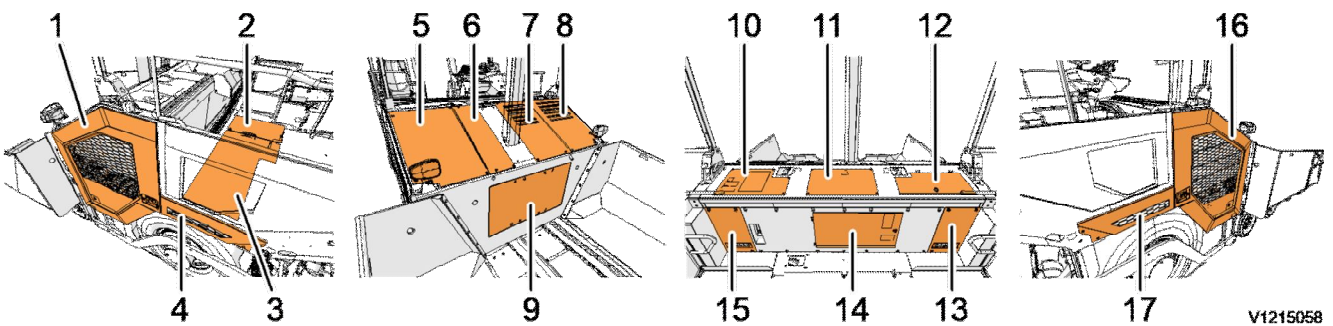

V1215058

**Figure 2**  
Maintenance hatches

Position	Description	Position	Description	Position	Description
1	Left service door	7	Left service plate	13	Service plate, operator's platform right
2	Left service hatch	8	Left service plate	14	Service hatch, operator's platform centre
3	Right service hatch	9	Service hatch, hopper	15	Service plate, operator's platform left
4	Protective grille, left	10	Service plate, top left	16	Right service door
5	Right service plate	11	Service plate, top centre	17	Protective grille right
6	Right service plate	12	Service hatch, top right		

Document Title: <b>Machine weights</b>	Function Group: <b>030</b>	Information Type: <b>Service Information</b>	Date: <b>4/28/2026</b>
Profile: <b>P6870D Volvo PID:12841268</b>			

[Go back to Index Page](#)

## Machine weights

Showing Selected Profile

<b>Valid for option/configuration</b>			
<b>Model</b>	<b>Option no.</b>	<b>Option</b>	<b>Configuration</b>
P6870D Volvo PID:12841268	17668820	Engine	D6J EU Stage V
P6870D Volvo PID:12841268	17668849	Engine	D6J China Stage IV

<b>Machine weight</b>	<b>14300 kg (31526 lb)</b>
<b>Machine weight (with balancing weight)</b>	<b>14720 kg (32452 lb)</b>

The machine weight is stated under the following conditions:

- Without screed
- With standard hopper
- Fuel tank half full
- Operator's weight 75 kg

Document Title: <b>Machine weights</b>	Function Group: <b>030</b>	Information Type: <b>Service Information</b>	Date: <b>4/28/2026</b>
Profile: <b>P6870D Volvo PID:12841268</b>			

[Go back to Index Page](#)

## Machine weights

Showing Selected Profile

<b>Valid for option/configuration</b>			
<b>Model</b>	<b>Option no.</b>	<b>Option</b>	<b>Configuration</b>
P6870D Volvo PID:12841268	17506505	Engine	D6E Stage IIIA

<b>Machine weight</b>	<b>14200 kg (31305 lb)</b>
<b>Machine weight (with balancing weight)</b>	<b>14620 kg (32231 lb)</b>

The machine weight is stated under the following conditions:

- Without screed
- With standard hopper
- Fuel tank half full
- Operator's weight 75 kg

Document Title: <b>Dimensions</b>	Function Group: <b>030</b>	Information Type: <b>Service Information</b>	Date: <b>4/28/2026</b>
Profile: <b>P6870D Volvo PID:12841268</b>			

### Dimensions

Showing Selected Profile

Valid for serial numbers			
Model	Production site	Serial number start	Serial number stop
P6870D Volvo PID:12841268			

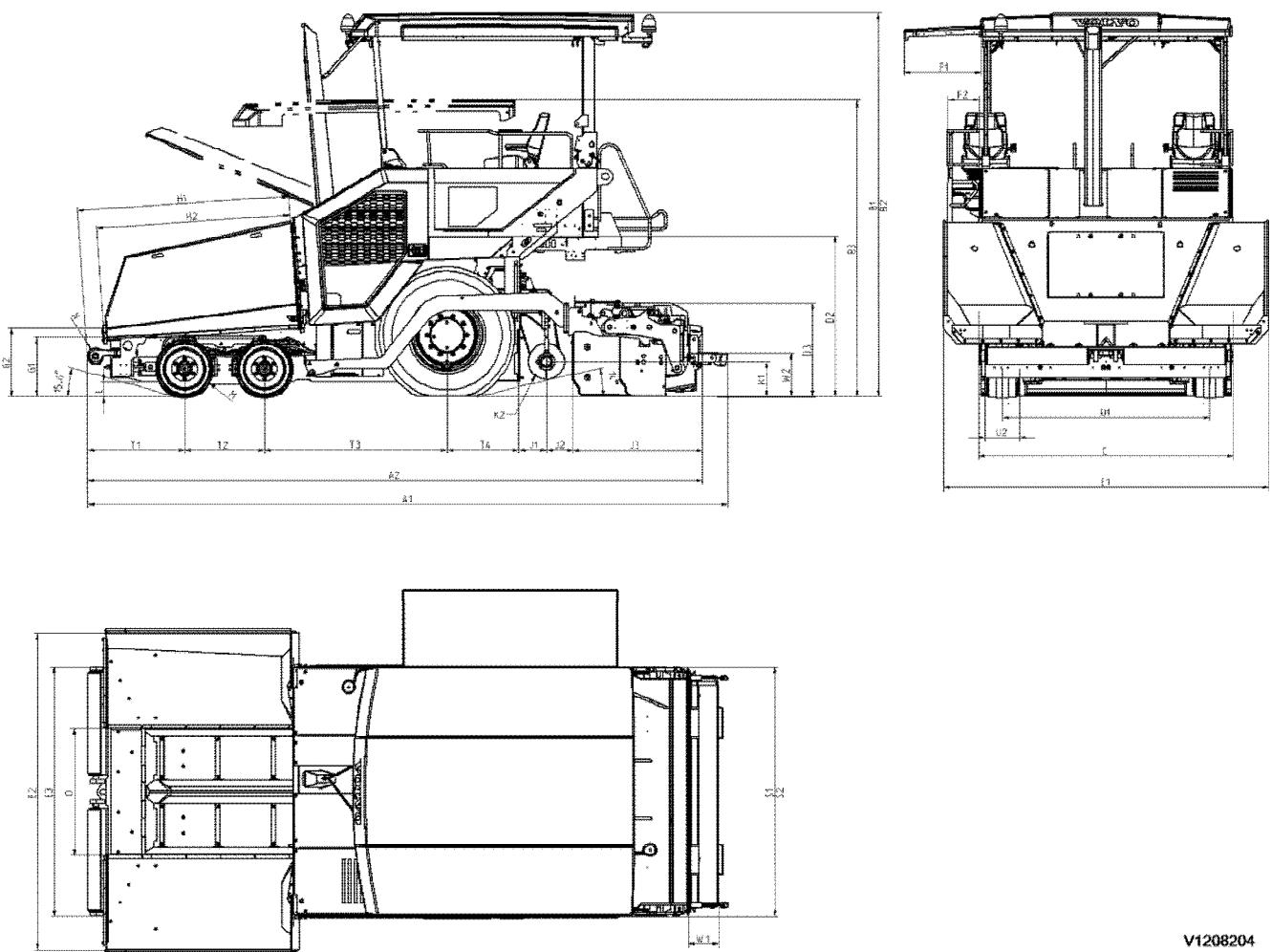

V1208204

**Figure 1**  
Dimensions, drawing

Pos.	Unit	Dimension	Designation	Remark
A1	mm	6402	Operating length	with walkway down
A2	mm	6152	Shipping length	with walkway up
B1	mm	3837	Operating height	highest point of either exhaust or rotating beacon of weather

B2	mm	3837	Height weather roof	roof height top of weather roof
B3	mm	2970	Shipping height	highest point with weather roof down or without weather roof
C	mm	2548	Tractor width	transport width of the machine
D1	mm	NA	Height railing	highest point without weather roof, often seat railing or paving panel from ground
D2	mm	1605	Deck height	height of platform to ground
D3	mm	938	Screed height	
E1	mm	3256	Outer hopper width	
E2	mm	3176	Inner hopper width	
E3	mm	2495	Width oscillating beam	width of oscillating beam with push rollers down
F1	mm	770	Extension weather roof	
F2	mm	317	Seat console extension	distance
G1	mm	592	Inner loading height	height to lowest point without rubber guard
G2	mm	688	Outer loading height	height to lowest point on hopper wings with rubber guard
H1	mm	2118	Hopper length to push roller	distance from rear wall to front cover
H2	mm	1939	Hopper length	distance from rear wall to front of hopper wing
J1	mm	275	Distance rear wall auger centre	
J2	mm	265	Distance auger centre screed	
J3	mm	1297	Screed depth	front wall screed to rear wall without walkway
K1	mm	350-60	Auger height to Ground (Centre)	position adjustment
K2	mm	360	Diameter auger	centre auger only
L	mm	145	Ground clearance	lowest point either front or tow point or rear
M	mm	540	Wheel diameter	front wheel diameter
N	mm	160	Diameter push roller	
O	mm	1270	Conveyor width	
S1	m	2.5	Basic screed width VB78+VB79	without end gates
	m	3.0	Basic screed width VB88	
S2	m	5.0	Extended screed width VB78+VB79	without end gates

	m	6.0	Basic screed width VB88	
T1	mm	970	Front wheel to push roller	distance centre front wheel to front of push roller
T2	mm	800	Distance front wheels	centre to centre
T3	mm	1825	Wheel base	centre rear wheel to centre second axle
T4	mm	720	Wheel distance to rear wall	centre rear wheel to rear wall
U1	mm	2076	Wheel gauge	wheels centre to centre
U2	mm	340	Wheel width	widest
W1	mm	305	Width of walkway	distance rear of screed to end of walkway
W2	mm	434	Height of walkway	height from ground, screed down

Document Title: <b>Conversion tables</b>	Function Group: <b>030</b>	Information Type: <b>Service Information</b>	Date: <b>4/28/2026</b>
Profile: <b>P6870D Volvo PID:12841268</b>			

## Conversion tables

Showing Selected Profile

Valid for serial numbers			
Model	Production site	Serial number start	Serial number stop
P6870D Volvo PID:12841268			

### Length

Unit	cm	m	km	in	ft	yd	mile
cm	1	0.01	0.00001	0.3937	0.03281	0.01094	0.000006
m	100	1	0.001	39.37	3.2808	1.0936	0.00062
km	100000	1000	1	39370.7	3280.8	1093.6	0.62137
in	2.54	0.0254	0.000025	1	0.08333	0.02777	0.000015
ft	30.48	0.3048	0.000304	12	1	0.3333	0.000189
yd	91.44	0.9144	0.000914	36	3	1	0.000568
mile	160930	1609.3	1.6093	63360	5280	1760	1

1 mm = 0.1 cm - 1 mm = 0.001 m

### Area

Unit	cm <sup>2</sup>	m <sup>2</sup>	km <sup>2</sup>	a	ft <sup>2</sup>	yd <sup>2</sup>	in <sup>2</sup>
cm <sup>2</sup>	1	0.0001	-	0.000001	0.001076	0.000012	0.155000
m <sup>2</sup>	10000	1	0.000001	0.01	10.764	1.1958	1550.000
km <sup>2</sup>	-	1000000	1	10000	1076400	1195800	-
a	0.01	100	0.0001	1	1076.4	119.58	-
ft <sup>2</sup>	-	0.092903	-	0.000929	1	0.1111	144.000
yd <sup>2</sup>	-	0.83613	-	0.008361	9	1	1296.00
in <sup>2</sup>	6.4516	0.000645	-	-	0.006943	0.000771	1

1 ha = 100 a - 1 mile<sup>2</sup> = 259 ha = 2.59 km<sup>2</sup>

### Volume

Unit	cm <sup>3</sup> = cc	m <sup>3</sup>	l	in <sup>3</sup>	ft <sup>3</sup>	yd <sup>3</sup>
cm <sup>3</sup> = ml	1	0.000001	0.001	0.061024	0.000035	0.000001
m <sup>3</sup>	1000000	1	1000	61024	35.315	1.30796
dm <sup>3</sup> (l)	1000	0.001	1	61.024	0.035315	0.001308
in <sup>3</sup>	16.387	0.000016	0.01638	1	0.000578	0.000021
ft <sup>3</sup>	28316.8	0.028317	28.317	1728	1	0.03704
yd <sup>3</sup>	764529.8	0.76453	764.53	46656	27	1

1 gal (US) = 3785.41 cm<sup>3</sup> = 231 in<sup>3</sup> = 0.83267 gal (UK)

### Weight

Unit	g	kg	t	oz	lb
g	1	0.001	0.000001	0.03527	0.0022
kg	1000	1	0.001	35.273	2.20459
t	1000000	1000	1	35273	2204.59
oz	28.3495	0.02835	0.000028	1	0.0625
lb	453.592	0.45359	0.000454	16	1

1 ton (metric) = 1.1023 ton (US) = 0.9842 ton (UK)

### Pressure

Unit	kp/cm <sup>2</sup>	bar	Pa=N/m <sup>2</sup>	kPa	lbf/in <sup>2</sup>	lbf/ft <sup>2</sup>
kp/cm <sup>2</sup>	1	0.98067	98066.5	98.0665	14.2233	2048.16
bar	1.01972	1	100000	100	14.5037	2088.6
Pa=N/m <sup>2</sup>	0.00001	0.001	1	0.001	0.00015	0.02086
kPa	0.01020	0.01	1000	1	0.14504	20.886
lbf/in <sup>2</sup>	0.07032	0.0689	6894.76	6.89476	1	144
lbf/ft <sup>2</sup>	0.00047	0.00047	47.88028	0.04788	0.00694	1

kg/cm<sup>2</sup> = 735.56 Dry (mmHg) = 0.96784 atm

### Unit explanations

Unit	abbreviation
Newton meter	Nm
Kilopoundmeter	kpm
Kilopascal	kPa
Megapascal	MPa
Kilowatt	kW
kilojoule	kJ
British thermal unit	Btu
Calorie	cal

### Approx. conversion

SI unit	Conversion factor	Non SI	Conversion factor	SI
<b>Torque</b>				
Nm	x10.2	=kg/cm	x0.8664	=lb in
Nm	x0.74	=lbf-ft	x1.36	=Nm
Nm	x0.102	=kg/m	x7.22	=lbft
<b>Pressure (Pa = N/m<sup>2</sup>)</b>				
kPa	x4.0	=in.H <sub>2</sub> O	x0.249	=kPa
kPa	x0.30	=in.Hg	x3.38	=kPa
kPa	x0.145	=psi	x6.89	=kPa
bar	x14.5	=psi	x0.069	=bar
kp/cm <sup>2</sup>	x14.22	=psi	x0.070	=kp/cm <sup>2</sup>
N/mm <sup>2</sup>	x145.04	=psi	x0.069	=bar
MPa	x145	=psi	x0.00689	=MPa
<b>Power (W = J/s)</b>				
kW	x1.36	=hp(cv)	x0.736	=kW

kW	x1.34	= bhp	x0.746	= kW
kW	x0.948	= Btu/s	x1.055	= kW
W	x0.74	= ft-lb/s	x1.36	= W
Energy (J = Nm)				
kJ	x0.948	= Btu	x1.055	= kJ
J	x0.239	= calorie	x4.19	= J
Speed and acceleration				
m/s <sup>2</sup>	x3.28	= ft/s <sup>2</sup>	x0.305	= m/s <sup>2</sup>
m/s	x3.28	= ft/s	x0.305	= m/s
km/h	x0.62	= mph	x1.61	= km/h
Horsepower/torque				
Bhp x5252 rpm = TQ (lb-ft)			TQ x rpm 5252 = bhp	
Temperature				
$^{\circ}\text{C} = (^{\circ}\text{F} - 32) / 1.8$			$^{\circ}\text{F} = (^{\circ}\text{C} \times 1.8) + 32$	
Flow factor				
l/min (dm <sup>3</sup> /min)	x0.264	= US gal/min	x3.785	= liter/min

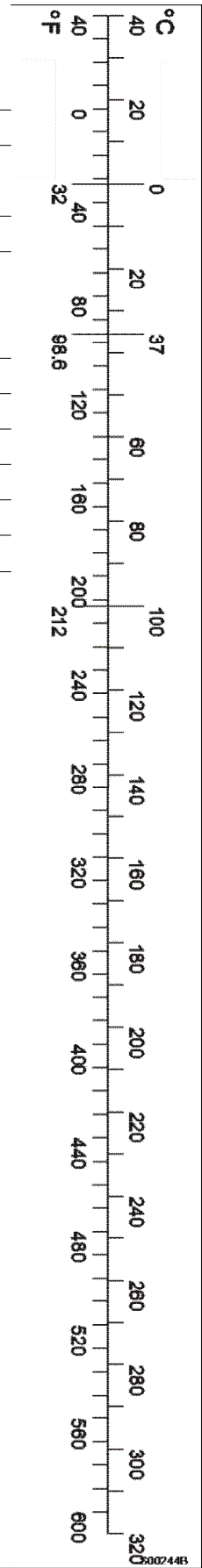

Document Title: <b>Loading</b>	Function Group: <b>050</b>	Information Type: <b>Service Information</b>	Date: <b>4/28/2026</b>
Profile: <b>P6870D Volvo PID:12841268</b>			

## Loading

Showing Selected Profile

Valid for serial numbers			
Model	Production site	Serial number start	Serial number stop
P6870D Volvo PID:12841268			

### Transport data

The given instructions for loading and securing the loaded machine are only valid if the following conditions are fulfilled:

<b>Maximum machine weight</b>		190000 N
<b>Factor longitudinal to driving direction</b>	<b>Braking</b>	0.8 (0.8)
	<b>Accelerating</b>	0.8 (0.8)
	<b>Driving in curves</b>	0.5 (0.5)
<b>Friction angle <math>\gamma</math></b> (Steel with rubber)		24 ° (24°)
<b>Friction coefficient <math>\mu</math></b>		0.45 (0.45)
<b>Loading platform surface</b>		Wood or metal <b>No oil — No ice — No soil — No mud</b>

<b>Load handling attachments and slings according to standard</b>	EN 12195
<b>Chain lashing capacity</b>	10000 daN
<b>Appropriate slings</b>	textile lashing belt with protective cover or edging strip
<b>Standard chain tension force for one chain</b>	depending on the lashing method, page <a href="#">Tying down machine</a>

Document Title: <b>Tying down machine</b>	Function Group: <b>050</b>	Information Type: <b>Service Information</b>	Date: <b>4/28/2026</b>
Profile: <b>P6870D Volvo PID:12841268</b>			

## Tying down machine

Showing Selected Profile

Valid for serial numbers			
Model	Production site	Serial number start	Serial number stop
P6870D Volvo PID:12841268			

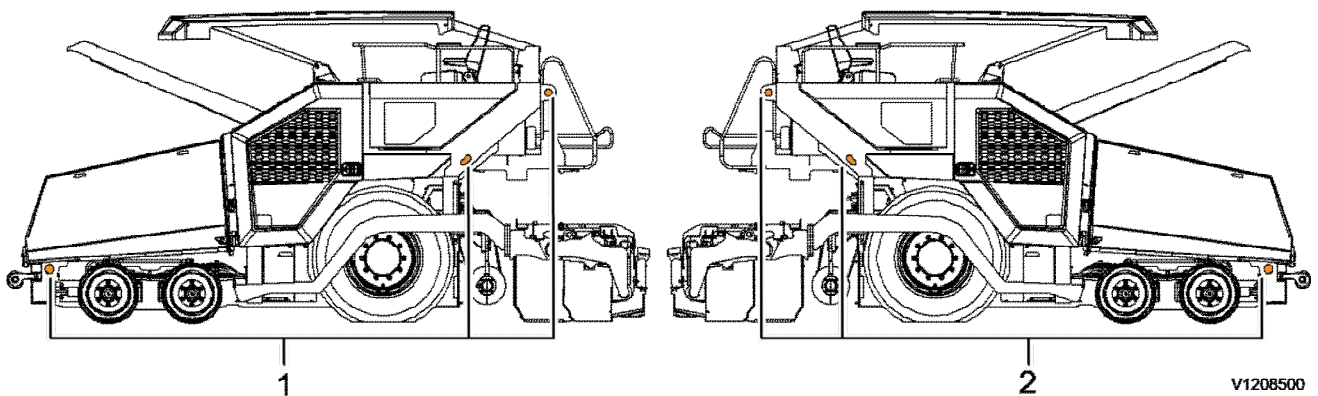

**Figure 1**

Lashing points

1. Machine lashing points, left
  2. Machine lashing points, right
- 
1. From the following lashing methods, select the one that is best suited to your situation.
  2. Select suitable load handling attachments, see also page [Loading](#).
  3. Lash the machine according to the lashing method selected so that the machine cannot tip over or roll away. The positions of all lashing eyes and lifting points can be found on page [International decals](#).

### Lashing method 1

<b>APPLY Chain tension STF</b>	<b>min. 400 daN</b>
--------------------------------	---------------------

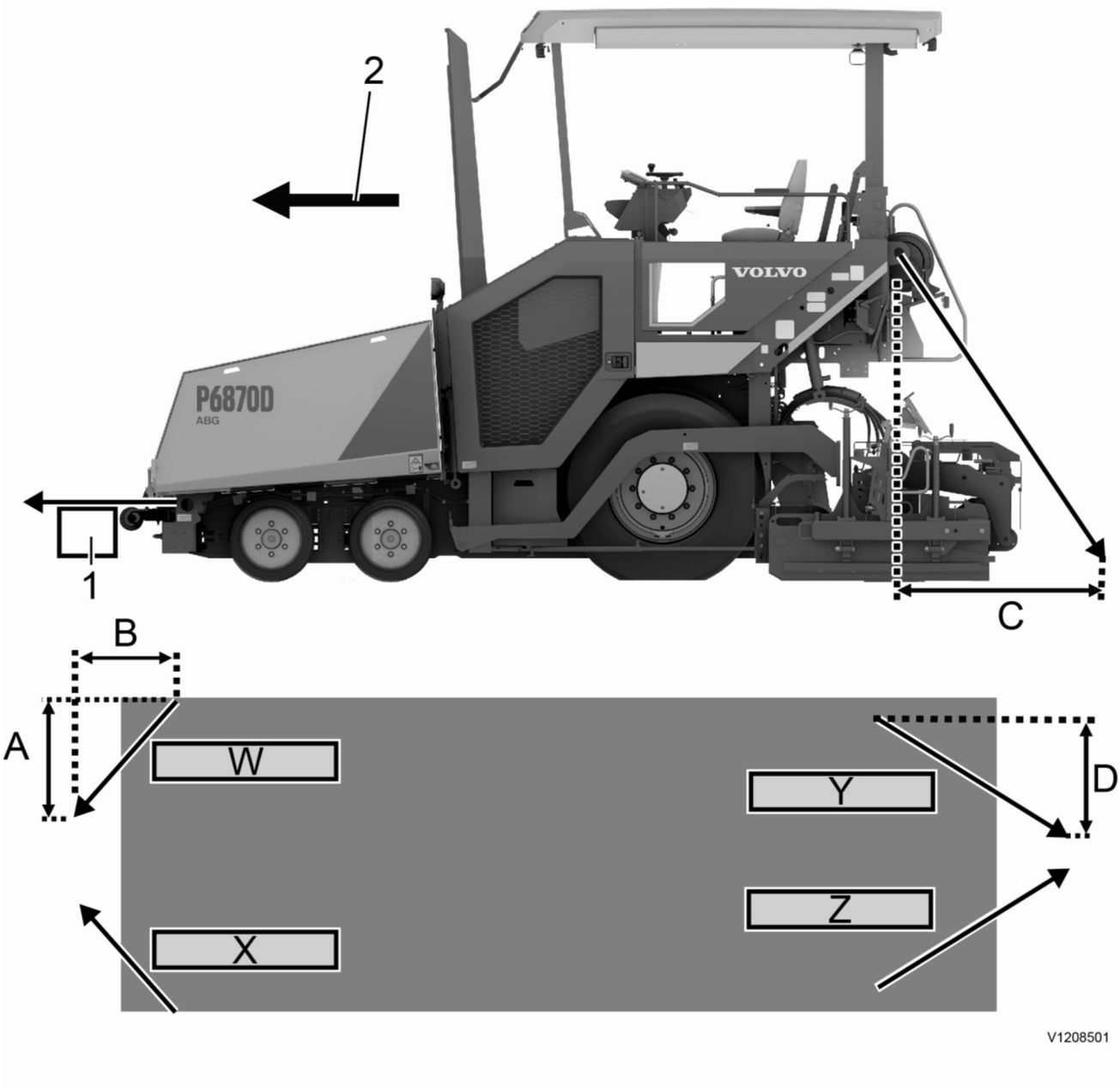

**Figure 2**  
Lashing method 1

1. Stop (fixed to low loader), recommended
2. Loading direction

Distance between lashing point and projected tie-down point		Standard Tension Force (STF)	
A	0.3 m - 2.8 m (0,98 ft - 9,19 ft)	W	Min. 400 daN
B	1.3 m - 3 m (4,27 ft - 9,84 ft)	X	
C	1.3 m - 3 m (4,27 ft - 9,84 ft)	Y	
D	0.5 m - 2.8 m (1,64 ft - 9,19 ft)	Z	

**Lashing method 2**

APPLY Chain tension STF W/X	min. 400 daN
APPLY Chain tension STF Y/Z	min. 2800 daN

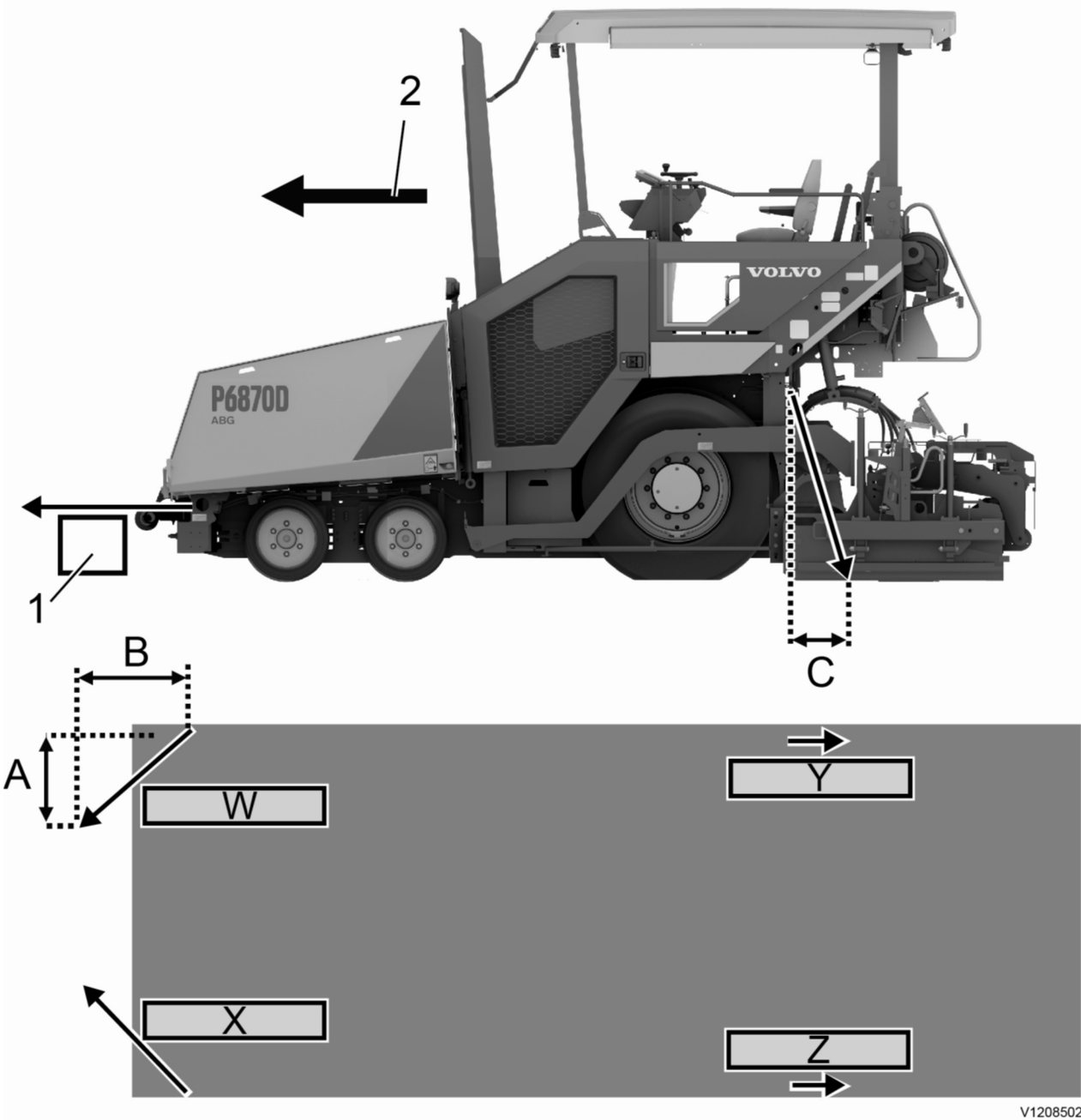

V1208502

**Figure 3**  
Lashing method 2

1. Stop (fixed to low loader), recommended
2. Loading direction

Distance between lashing point and projected tie-down point		Standard Tension Force (STF)	
A	0.3 m - 2.8 m (0,98 ft - 9,19 ft)	W	400 daN
B	1.3 m - 3 m (4,27 ft - 9,84 ft)	X	2800 daN
C	0.1 m - 0.4 m (0,33 ft - 1,31 ft)	Y	
		Z	

**Lashing method 3**

<b>APPLY Chain tension STF</b>	<b>min. 2800 daN</b>
--------------------------------	----------------------

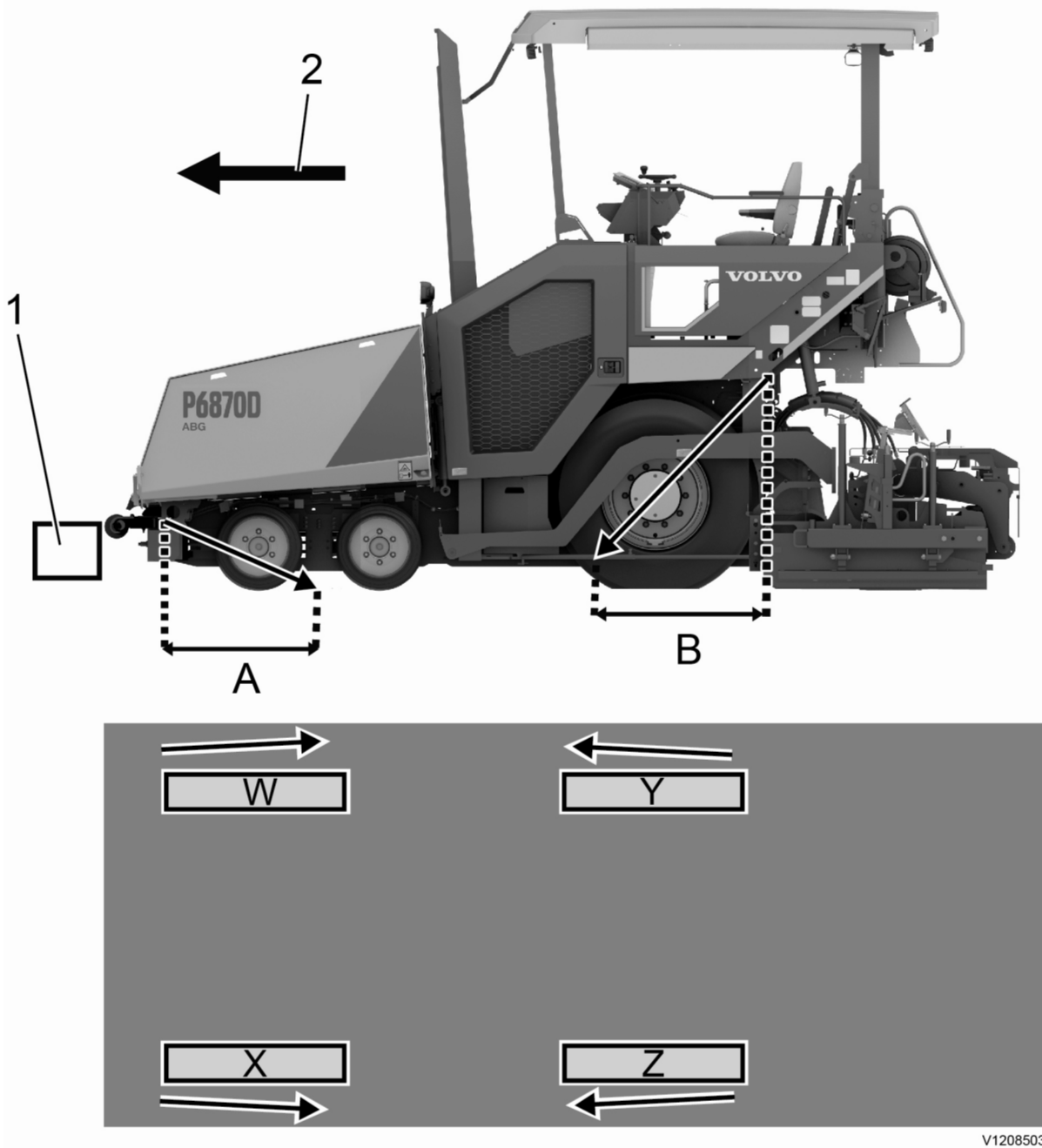

V1208503

**Figure 4**  
Lashing method 3

1. Stop (fixed to low loader), recommended
2. Loading direction

Distance between lashing point and projected tie-down point		Standard Tension Force (STF)	
A	0.2 m - 1 m (0,66 ft - 3,28 ft)	W	2800 daN
		X	
B	0 m - 1.8 m (0 ft - 5,91 ft)	Y	
		Z	

Document Title: <b>Transporting the machine under its own power</b>	Function Group: <b>050</b>	Information Type: <b>Service Information</b>	Date: <b>4/28/2026</b>
Profile: <b>P6870D Volvo PID:12841268</b>			

## Transporting the machine under its own power

Showing Selected Profile

Valid for serial numbers			
Model	Production site	Serial number start	Serial number stop
P6870D Volvo PID:12841268			



**Risk of serious accidents.**

**Unexpectedly moving machine parts may cause serious injuries.**

**Carefully follow the locking procedures before travelling on public roads.**

**NOTE!**

If you intend to drive on public roads, make sure that the machine complies with all local regulations for driving on public roads.

**You may need approval for road use from the regional authority, a rotating beacon or on-street lights.**

1. Raise the all-weather roof. Lock the all-weather roof support.
2. Remove all loose objects from the machine.
3. Raise the augers to their highest position.
4. Empty the hopper.
5. Close and lock the hopper.
6. Lock the direction indicator.
7. Remove all screed attachments, see the operator's manual for the screed.
8. Lock the swivelling arms of the screed.
9. Raise the towing arm into transport position and lock the screed transport lock.
10. Secure and mark the machine for driving in accordance with local regulations.
11. Use all prescribed warning devices and lights.
12. Select the gear:

- Paver with screed:**

**NOTE!**

You must only use transport gear when the hopper is empty, closed and locked.

Engage the **working or transport gear**.

- Paver without screed:**



Risk of serious injuries.

Paver without screed has a longer braking distance which could cause accidents with serious injuries.

**Drive in working gear only, if no screed is attached.**

Engage the ***working gear***.

13. When driving, pay particular attention to other traffic. Observe all valid road traffic regulations.
14. If possible, do not park the machine on public roads.
15. Secure and mark the machine for parking in accordance with local regulations.

Document Title: <b>Loading the machine under its own power</b>	Function Group: <b>050</b>	Information Type: <b>Service Information</b>	Date: <b>4/28/2026</b>
Profile: <b>P6870D Volvo PID:12841268</b>			

## Loading the machine under its own power

Showing Selected Profile

Valid for serial numbers			
Model	Production site	Serial number start	Serial number stop
P6870D Volvo PID:12841268			



### **WARNING**

Risk of serious injury.

The machine could tilt while loading on to or unloading from the transporter. Tilting of the machine will cause the operator to fall off which could result in serious injury.

**Ensure to approach the loading ramps squarely. Always use a signal person to assist while loading or unloading the machine.**

1. Choose a level and firm area where the transport vehicle can stand safely.
2. Clean the transport platform and loading ramps.
3. Remove the gas cylinders, if the screed is fitted with gas heating system.
4. Move the auger to the top position.
5. Fully raise the screed and then retract it.
6. Secure the transport vehicle against rolling.
7. Accept the help of a second person.
8. Start the engine.
9. Drive straight onto the loading ramps of the transport vehicle so that the machine cannot slip sideways from the ramp.
10. Drive the machine straight onto the transport vehicle.
11. Lower the screed to the loading platform of the transport vehicle.
12. Switch off the engine.
13. Remove the paving panel and screed panels and stow them in the storage compartment provided for this purpose.
14. Secure the driving panel against vandalism.
15. Close the front windshield.
16. Lower the all-weather roof.
17. Switch off the battery disconnect switch.
18. Secure the machine onto the transport vehicle.

Document Title: <b>Loading the machine with crane</b>	Function Group: <b>050</b>	Information Type: <b>Service Information</b>	Date: <b>4/28/2026</b>
Profile: <b>P6870D Volvo PID:12841268</b>			

## Loading the machine with crane

Showing Selected Profile

Valid for serial numbers			
Model	Production site	Serial number start	Serial number stop
P6870D Volvo PID:12841268			



Risk of crushing.

A suspended machine could fall. A falling machine will cause fatal injury to persons below.

**Never step under a suspended machine.**

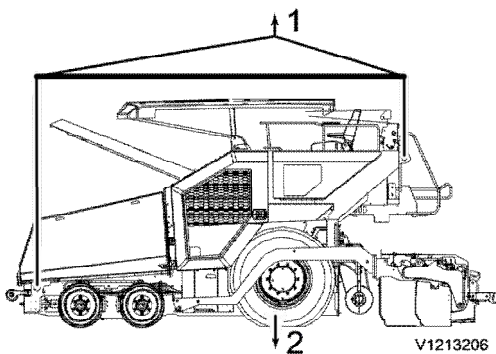

**Figure 1**

Loading with a crane

1. Suspension point
2. Centre of gravity



**Figure 2**

Sticker, "Lifting point"

1. Select an even, firm base on which the transport vehicle and crane can stand securely.
2. Select the crane, transport vehicle and lifting tool according to the weight of the machine and the lifting conditions.
3. Remove the screed end plates and all screed attachments, see the operator's manual for the screed.
4. Start the engine.
5. Lower the screed to the ground.
6. Close and lock the hopper.
7. Stop the engine.

8. Remove and stow the paving panel and screed panels.
9. Secure the driving panel to prevent vandalism.
10. Remove all loose objects from the machine.
11. Lower the all-weather roof. Lock the all-weather roof support.
12. Switch off the battery disconnect switch.
13. Position the crane with traverse close to the machine.  
Get a second person to help when positioning the crane and loading the machine.
14. **Use a traverse.**  
Attach the lifting slings to the lifting points marked with the "Lifting point" decal.
15. Balance the machine around its the centre of gravity (2).
16. After attaching the lifting slings, the suspension point (1) of the load must be brought into the vertical position above the centre of gravity of the machine.  
**The centre of gravity (2) is dependent on the mounted screed. The centre of gravity of the machine with the screed mounted is always in the area in front of the rear wheel axle.**
17. Safely lash the machine on the transport vehicle.

Document Title: <b>Operation numbers for additional work</b>	Function Group: <b>070</b>	Information Type: <b>Service Information</b>	Date: <b>4/28/2026</b>
Profile: <b>Wheeled Pavers (PAW)</b>			

## Operation numbers for additional work

Showing Selected Profile

These operations can be used to identify work that is not included in the time guide or described in the methods in the Service Manual. When these operations are used, a description of the work that has been performed must be provided.

### Other work related to engine

Op. no. 070-210

This operation can be used when work has been done related to the engine and function group 2 when no applicable method description was available. When this operation is used, additional information is required:

- Description of work that has been done

### Other work related to electrical system

Op. no. 070-310

This operation can be used when work has been done related to the electrical system and function group 3 when no applicable method description was available. When this operation is used, additional information is required:

- Description of work that has been done

### Other work related to transmission, gearbox, travel motor, swing motor

Op. no. 070-410

This operation can be used when work has been done related to the transmission, gearbox, travel motor or swing motor and function group 4 when no applicable method description was available. When this operation is used, additional information is required:

- Description of work that has been done

### Other work related to drive axle

Op. no. 070-470

This operation can be used when work has been done related to the drive axle and function group 46 when no applicable method description was available. When this operation is used, additional information is required:

- Description of required work that have been done

### Other work related to brake system

Op. no. 070-510

This operation can be used when work has been done related to the brake system and function group 5 when no applicable

method description was available. When this operation is used, additional information is required:

- Description of work that has been done

**Other work related to steering system**

Op. no. 070-610

This operation can be used when work has been done related to the steering system and function group 6 when no applicable method description was available. When this operation is used, additional information is required:

- Description of work that has been done

**Other work related to frame link, axle suspension**

Op. no. 070-710

This operation can be used when work has been done related to the frame link, axle suspension and other parts related to function group 7 when no applicable method description was available. When this operation is used, additional information is required:

- Description of work that has been done

**Other work related to cab, air conditioning**

Op. no. 070-810

This operation can be used when work has been done related to the cab, air conditioning and other parts related to function group 8 when no applicable method description was available. When this operation is used, additional information is required:

- Description of work that has been done

**Other work related to hydraulic system**

Op. no. 070-910

This operation can be used when work has been done related to the hydraulic system and other parts related to function group 9 when no applicable method description was available. When this operation is used, additional information is required:

- Description of work that has been done

Document Title: <b>E-2030</b>	Function Group: <b>080</b>	Information Type: <b>Service Information</b>	Date: <b>4/28/2026</b>
Profile: <b>P6870D Volvo PID:12841268</b>			

### E-2030

Showing Selected Profile

Valid for serial numbers			
Model	Production site	Serial number start	Serial number stop
P6870D Volvo PID:12841268			

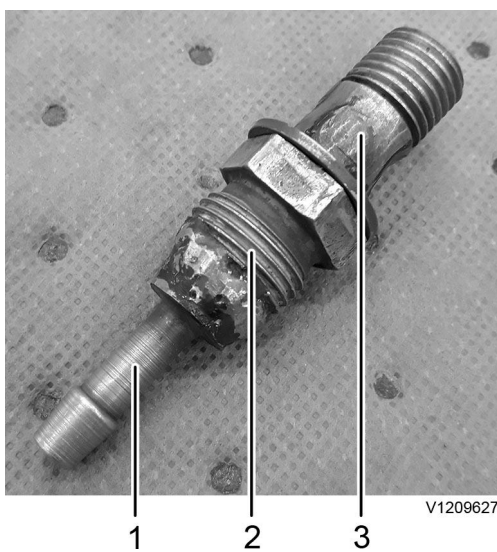

**Figure 1**

1. Hose nipple, diameter of approx. 8 mm
2. 21023622
3. Holes welded shut

Document Title: <b>E-2032</b>	Function Group: <b>080</b>	Information Type: <b>Service Information</b>	Date: <b>4/28/2026</b>
Profile: <b>P6870D Volvo PID:12841268</b>			

## E-2032

Showing Selected Profile

Valid for serial numbers			
Model	Production site	Serial number start	Serial number stop
P6870D Volvo PID:12841268			



**Figure 1**

1. 995895
2. Washers (2 pcs)

Document Title: <b>E-7008</b>	Function Group: <b>080</b>	Information Type: <b>Service Information</b>	Date: <b>4/28/2026</b>
Profile: <b>P6870D Volvo PID:12841268</b>			

### E-7008

Showing Selected Profile

Valid for serial numbers			
Model	Production site	Serial number start	Serial number stop
P6870D Volvo PID:12841268			

All dimensions in mm.

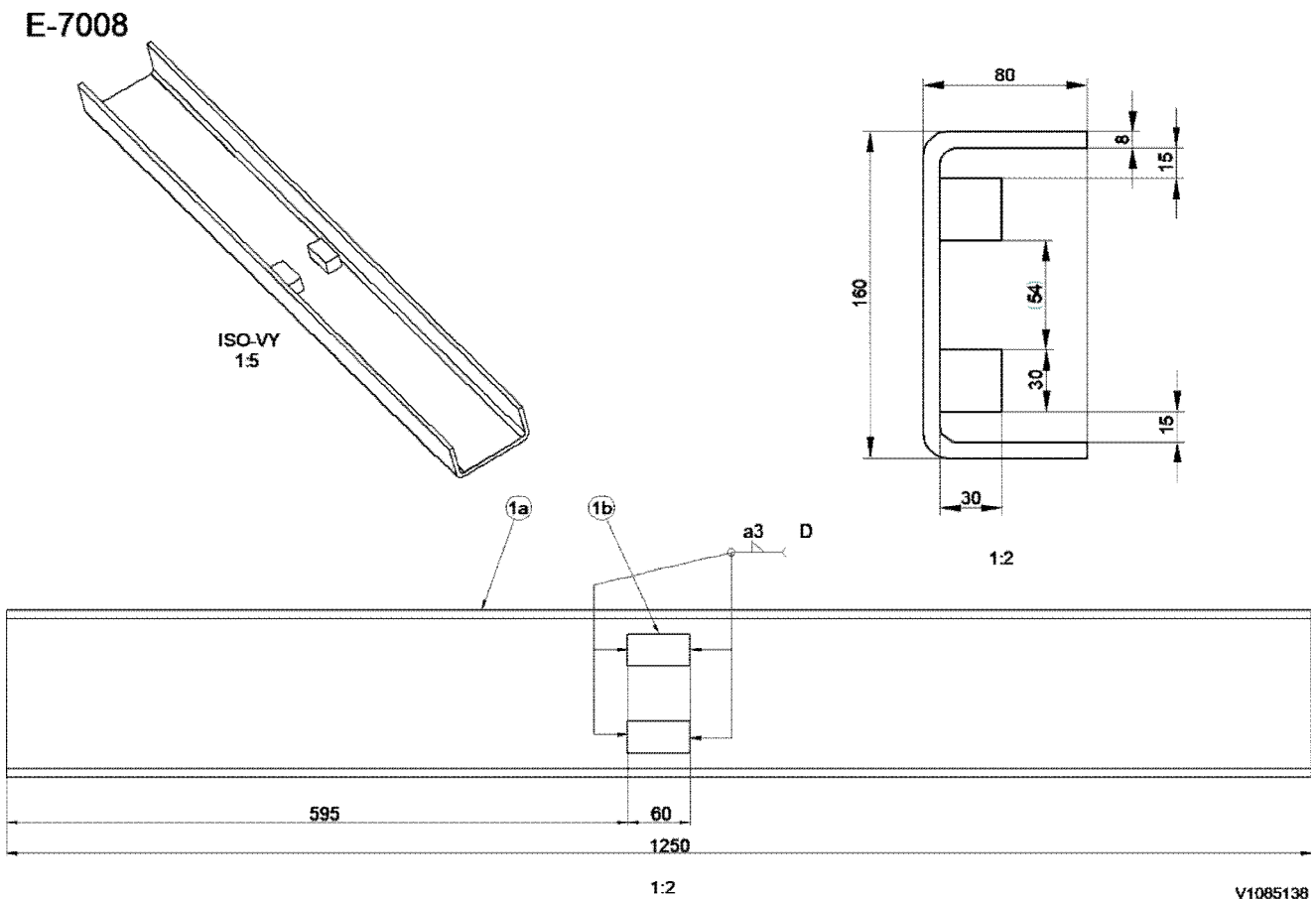

V1085138

**Figure 1**

E-7008 U bar

Material: S355 JR or better.

Document Title: <b>E-7009</b>	Function Group: <b>080</b>	Information Type: <b>Service Information</b>	Date: <b>4/28/2026</b>
Profile: <b>P6870D Volvo PID:12841268</b>			

### E-7009

Showing Selected Profile

Valid for serial numbers			
Model	Production site	Serial number start	Serial number stop
P6870D Volvo PID:12841268			

All dimensions in mm.

#### E-7009

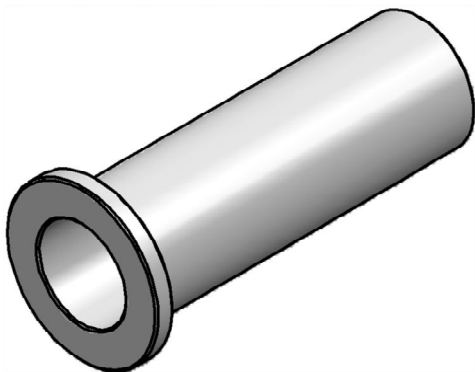
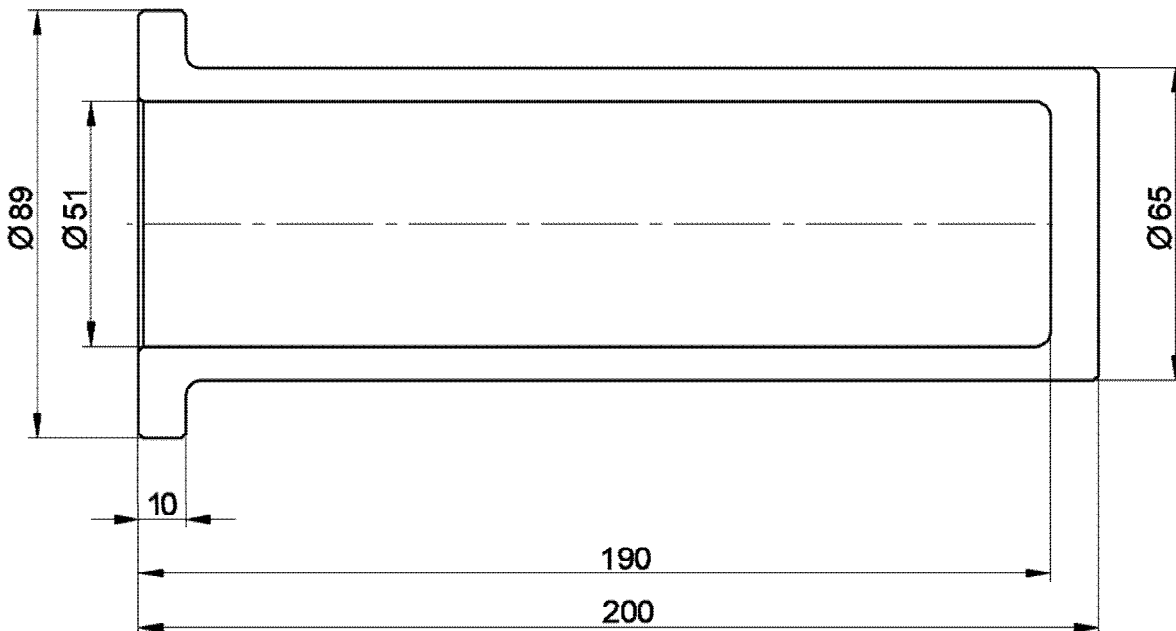

V1086432

**Figure 1**

E-7009 Drift

Material: S355 JR or better.

Product: P6870D Volvo Wheeled Pavers Service Manual

Full Download: <https://www.arepairmanual.com/downloads/p6870d-volvo-wheeled-pavers-service-manual/>

**V O L V O**

## Service Information

Document Title: <b>E-7014</b>	Function Group: <b>080</b>	Information Type: <b>Service Information</b>	Date: <b>4/28/2026</b>
Profile: <b>P6870D Volvo PID:12841268</b>			

## E-7014

Showing Selected Profile

Valid for serial numbers			
Model	Production site	Serial number start	Serial number stop
P6870D Volvo PID:12841268			

All dimensions in mm.

Sample manual. Download All 2298 pages at:

<https://www.arepairmanual.com/downloads/p6870d-volvo-wheeled-pavers-service-manual/>