



Document Title: <b>Volvo standard tightening torques</b>	Function Group: <b>030</b>	Information Type: <b>Service Information</b>	Date: <b>4/19/2026</b>
Profile: <b>L90H Volvo</b>			

## Volvo standard tightening torques

Showing Selected Profile

Valid for serial numbers			
Model	Production site	Serial number start	Serial number stop
L90H Volvo			

The tightening torques in the following tables apply to bolts and nuts with tensile strength. The tables should be used as a general instruction for tightening bolts and nuts without specified values. The charts contains values for course thread bolts and nuts.

Torque values should be increased with  $\approx 10\%$ , for flange bolts.

All standard torques for bolts are without surface treatment.

The standard torque for bolts lubricated with oil should be reduced with 20% of the given value.

### Standard tightening torque charts

Bolt size Metric Coarse Threads	Tensile strength 8.8		Tensile strength 10.9	
	(Nm)	(lbf ft)	(Nm)	(lbf ft)
M5	6	4	8	6
M6	10	7	14	11
M8	25	18	35	26
M10	50	37	70	52
M12	87	64	122	90
M14	139	103	195	144
M16	213	157	299	220
M18	293	216	413	305
M20	416	307	585	432
M24	719	530	1010	745
M27	1060	782	1490	1100
M30	1140	840	2025	1493
M36	2500	1844	3600	2653

Bolt size Inch SAE Coarse Threads	Tensile strength 5		Tensile strength 8	
	(lbf ft)	(Nm)	(lbf ft)	(Nm)
1/4	10	13,6	14	19
5/16	21	28,5	29	39,3
3/8	37	50,2	52	70
7/16	59	80	84	114
1/2	90	122	128	174
9/16	130	176	184	250
5/8	200	271	284	388
3/4	270	365	384	520
7/8	350	474	500	672
1	450	608	640	860
1 1/8	600	814	850	1130
1 1/4	750	1019	1060	1420
1 3/8	900	1224	1280	1720
1 1/2	1100	1488	1550	2090
1 3/4	1350	1842	1920	2590
2	1800	2457	2560	3440
2 1/4	2250	3072	3200	4290
2 3/4	2700	3687	3840	5140
3	3150	4302	4480	6000
3 1/2	3600	4917	5120	6850
4	4050	5532	5760	7700
4 1/2	4500	6147	6400	8550
5	4950	6762	7040	9400
5 1/2	5400	7377	7680	10250
6	5850	7992	8320	11100
6 1/2	6300	8607	8960	11950
7	6750	9222	9600	12800
7 1/2	7200	9837	10240	13650
8	7650	10452	10880	14500
8 1/2	8100	11067	11520	15350
9	8550	11682	12160	16200
9 1/2	9000	12297	12800	17050
10	9450	12912	13440	17900
10 1/2	9900	13527	14080	18750
11	10350	14142	14720	19600
11 1/2	10800	14757	15360	20450
12	11250	15372	16000	21300
12 1/2	11700	15987	16640	22150
13	12150	16602	17280	23000
13 1/2	12600	17217	17920	23850
14	13050	17832	18560	24700
14 1/2	13500	18447	19200	25550
15	13950	19062	19840	26400
15 1/2	14400	19677	20480	27250
16	14850	20292	21120	28100
16 1/2	15300	20907	21760	28950
17	15750	21522	22400	29800
17 1/2	16200	22137	23040	30650
18	16650	22752	23680	31500
18 1/2	17100	23367	24320	32350
19	17550	23982	24960	33200
19 1/2	18000	24597	25600	34050
20	18450	25212	26240	34900
20 1/2	18900	25827	26880	35750
21	19350	26442	27520	36600
21 1/2	19800	27057	28160	37450
22	20250	27672	28800	38300
22 1/2	20700	28287	29440	39150
23	21150	28902	30080	40000
23 1/2	21600	29517	30720	40850
24	22050	30132	31360	41700
24 1/2	22500	30747	32000	42550
25	22950	31362	32640	43400
25 1/2	23400	31977	33280	44250
26	23850	32592	33920	45100
26 1/2	24300	33207	34560	45950
27	24750	33822	35200	46800
27 1/2	25200	34437	35840	47650
28	25650	35052	36480	48500
28 1/2	26100	35667	37120	49350
29	26550	36282	37760	50200
29 1/2	27000	36897	38400	51050
30	27450	37512	39040	51900
30 1/2	27900	38127	39680	52750
31	28350	38742	40320	53600
31 1/2	28800	39357	40960	54450
32	29250	39972	41600	55300
32 1/2	29700	40587	42240	56150
33	30150	41202	42880	57000
33 1/2	30600	41817	43520	57850
34	31050	42432	44160	58700
34 1/2	31500	43047	44800	59550
35	31950	43662	45440	60400
35 1/2	32400	44277	46080	61250
36	32850	44892	46720	62100
36 1/2	33300	45507	47360	62950
37	33750	46122	48000	63800
37 1/2	34200	46737	48640	64650
38	34650	47352	49280	65500
38 1/2	35100	47967	49920	66350
39	35550	48582	50560	67200
39 1/2	36000	49197	51200	68050
40	36450	49812	51840	68900
40 1/2	36900	50427	52480	69750
41	37350	51042	53120	70600
41 1/2	37800	51657	53760	71450
42	38250	52272	54400	72300
42 1/2	38700	52887	55040	73150
43	39150	53502	55680	74000
43 1/2	39600	54117	56320	74850
44	40050	54732	56960	75700
44 1/2	40500	55347	57600	76550
45	40950	55962	58240	77400
45 1/2	41400	56577	58880	78250
46	41850	57192	59520	79100
46 1/2	42300	57807	60160	79950
47	42750	58422	60800	80800
47 1/2	43200	59037	61440	81650
48	43650	59652	62080	82500
48 1/2	44100	60267	62720	83350
49	44550	60882	63360	84200
49 1/2	45000	61497	64000	85050
50	45450	62112	64640	85900
50 1/2	45900	62727	65280	86750
51	46350	63342	65920	87600
51 1/2	46800	63957	66560	88450
52	47250	64572	67200	89300
52 1/2	47700	65187	67840	90150
53	48150	65802	68480	91000
53 1/2	48600	66417	69120	91850
54	49050	67032	69760	92700
54 1/2	49500	67647	70400	93550
55	49950	68262	71040	94400
55 1/2	50400	68877	71680	95250
56	50850	69492	72320	96100
56 1/2	51300	70107	72960	96950
57	51750	70722	73600	97800
57 1/2	52200	71337	74240	98650
58	52650	71952	74880	99500
58 1/2	53100	72567	75520	100350
59	53550	73182	76160	101200
59 1/2	54000	73797	76800	102050
60	54450	74412	77440	102900
60 1/2	54900	75027	78080	103750
61	55350	75642	78720	104600
61 1/2	55800	76257	79360	105450
62	56250	76872	80000	106300
62 1/2	56700	77487	80640	107150
63	57150	78102	81280	108000
63 1/2	57600	78717	81920	108850
64	58050	79332	82560	109700
64 1/2	58500	79947	83200	110550
65	58950	80562	83840	111400
65 1/2	59400	81177	84480	112250
66	59850	81792	85120	113100
66 1/2	60300	82407	85760	113950
67	60750	83022	86400	114800
67 1/2	61200	83637	87040	115650
68	61650	84252	87680	116500
68 1/2	62100	84867	88320	117350
69	62550	85482	88960	118200
69 1/2	63000	86097	89600	119050
70	63450	86712	90240	119900
70 1/2	63900	87327	90880	120750
71	64350	87942	91520	121600
71 1/2	64800	88557	92160	122450
72	65250	89172	92800	123300
72 1/2	65700	89787	93440	124150
73	66150	90402	94080	125000
73 1/2	66600	91017	94720	125850
74	67050	91632	95360	126700
74 1/2	67500	92247	96000	127550
75	67950	92862	96640	128400
75 1/2	68400	93477	97280	129250
76	68850	94092	97920	130100
76 1/2	69300	94707	98560	130950
77	69750	95322	99200	131800
77 1/2	70200	95937	99840	132650
78	70650	96552	100480	133500
78 1/2	71100	97167	101120	134350
79	71550	97782	101760	135200
79 1/2	72000	98397	102400	136050
80	72450	99012	103040	136900
80 1/2	72900	99627	103680	137750
81	73350	100242	104320	138600
81 1/2	73800	100857	104960	139450
82	74250	101472	105600	140300
82 1/2	74700	102087	106240	141150
83	75150	102702	106880	142000
83 1/2	75600	103317	107520	142850
84	76050	103932	108160	143700
84 1/2	76500	104547	108800	144550
85	76950	105162	109440	145400
85 1/2	77400	105777	110080	146250
86	77850	106392	110720	147100
86 1/2	78300	107007	111360	147950
87	78750	107622	112000	148800
87 1/2	79200	108237	112640	149650
88	79650	108852	113280	150500
88 1/2	80100	109467	113920	151350
89	80550	110082	114560	152200
89 1/2	81000	110697	115200	153050
90	81450	111312	115840	153900
90 1/2	81900	111927	116480	154750
91	82350	112542	117120	155600
91 1/2	82800	113157	117760	156450
92	83250	113772	118400	157300
92 1/2	83700	114387	119040	158150
93	84150			

Product: L90H Volvo Wheel Loaders Service Manual

Full Download: <https://www.arepairmanual.com/downloads/l90h-volvo-wheel-loaders-service-manual/>

3/4	320	434	451	612
7/8	515	700	728	988
1	775	1052	1091	1480
1 1/8	953	1290	1545	2100
1 1/4	1344	1823	2180	2960
1 3/8	1600	2170	2650	3600
1 1/2	2000	2714	3200	4340

Sample manual. Download All 4900 pages at:

<https://www.arepairmanual.com/downloads/l90h-volvo-wheel-loaders-service-manual/>

Document Title: <b>Conversion tables</b>	Function Group: <b>030</b>	Information Type: <b>Service Information</b>	Date: <b>4/19/2026</b>
Profile: <b>L90H Volvo</b>			

## Conversion tables

Showing Selected Profile

Valid for serial numbers			
Model	Production site	Serial number start	Serial number stop
L90H Volvo			

### Length

Unit	cm	m	km	in	ft	yd	mile
cm	1	0.01	0.00001	0.3937	0.03281	0.01094	0.000006
m	100	1	0.001	39.37	3.2808	1.0936	0.00062
km	100000	1000	1	39370.7	3280.8	1093.6	0.62137
in	2.54	0.0254	0.000025	1	0.08333	0.02777	0.000015
ft	30.48	0.3048	0.000304	12	1	0.3333	0.000189
yd	91.44	0.9144	0.000914	36	3	1	0.000568
mile	160930	1609.3	1.6093	63360	5280	1760	1

1 mm = 0.1 cm - 1 mm = 0.001 m

### Area

Unit	cm <sup>2</sup>	m <sup>2</sup>	km <sup>2</sup>	a	ft <sup>2</sup>	yd <sup>2</sup>	in <sup>2</sup>
cm <sup>2</sup>	1	0.0001	-	0.000001	0.001076	0.000012	0.155000
m <sup>2</sup>	10000	1	0.000001	0.01	10.764	1.1958	1550.000
km <sup>2</sup>	-	1000000	1	10000	1076400	1195800	-
a	0.01	100	0.0001	1	1076.4	119.58	-
ft <sup>2</sup>	-	0.092903	-	0.000929	1	0.1111	144.000
yd <sup>2</sup>	-	0.83613	-	0.008361	9	1	1296.00
in <sup>2</sup>	6.4516	0.000645	-	-	0.006943	0.000771	1

1 ha = 100 a - 1 mile<sup>2</sup> = 259 ha = 2.59 km<sup>2</sup>

### Volume

Unit	cm <sup>3</sup> = cc	m <sup>3</sup>	l	in <sup>3</sup>	ft <sup>3</sup>	yd <sup>3</sup>
cm <sup>3</sup> = ml	1	0.000001	0.001	0.061024	0.000035	0.000001
m <sup>3</sup>	1000000	1	1000	61024	35.315	1.30796
dm <sup>3</sup> (l)	1000	0.001	1	61.024	0.035315	0.001308
in <sup>3</sup>	16.387	0.000016	0.01638	1	0.000578	0.000021
ft <sup>3</sup>	28316.8	0.028317	28.317	1728	1	0.03704
yd <sup>3</sup>	764529.8	0.76453	764.53	46656	27	1

1 gal (US) = 3785.41 cm<sup>3</sup> = 231 in<sup>3</sup> = 0.83267 gal (UK)

### Weight

Unit	g	kg	t	oz	lb
g	1	0.001	0.000001	0.03527	0.0022
kg	1000	1	0.001	35.273	2.20459
t	1000000	1000	1	35273	2204.59
oz	28.3495	0.02835	0.000028	1	0.0625
lb	453.592	0.45359	0.000454	16	1

1 ton (metric) = 1.1023 ton (US) = 0.9842 ton (UK)

### Pressure

Unit	kp/cm <sup>2</sup>	bar	Pa=N/m <sup>2</sup>	kPa	lbf/in <sup>2</sup>	lbf/ft <sup>2</sup>
kp/cm <sup>2</sup>	1	0.98067	98066.5	98.0665	14.2233	2048.16
bar	1.01972	1	100000	100	14.5037	2088.6
Pa=N/m <sup>2</sup>	0.00001	0.001	1	0.001	0.00015	0.02086
kPa	0.01020	0.01	1000	1	0.14504	20.886
lbf/in <sup>2</sup>	0.07032	0.0689	6894.76	6.89476	1	144
lbf/ft <sup>2</sup>	0.00047	0.00047	47.88028	0.04788	0.00694	1

kg/cm<sup>2</sup> = 735.56 Dry (mmHg) = 0.96784 atm

### Unit explanations

Unit	abbreviation
Newton meter	Nm
Kilopoundmeter	kpm
Kilopascal	kPa
Megapascal	MPa
Kilowatt	kW
kilojoule	kJ
British thermal unit	Btu
Calorie	cal

### Approx. conversion

SI unit	Conversion factor	Non SI	Conversion factor	SI
<b>Torque</b>				
Nm	x10.2	=kg/cm	x0.8664	=lb in
Nm	x0.74	=lbf-ft	x1.36	=Nm
Nm	x0.102	=kg/m	x7.22	=lbft
<b>Pressure (Pa = N/m<sup>2</sup>)</b>				
kPa	x4.0	=in.H <sub>2</sub> O	x0.249	=kPa
kPa	x0.30	=in.Hg	x3.38	=kPa
kPa	x0.145	=psi	x6.89	=kPa
bar	x14.5	=psi	x0.069	=bar
kp/cm <sup>2</sup>	x14.22	=psi	x0.070	=kp/cm <sup>2</sup>
N/mm <sup>2</sup>	x145.04	=psi	x0.069	=bar
MPa	x145	=psi	x0.00689	=MPa
<b>Power (W = J/s)</b>				
kW	x1.36	=hp(cv)	x0.736	=kW

kW	x1.34	= bhp	x0.746	= kW
kW	x0.948	= Btu/s	x1.055	= kW
W	x0.74	= ft-lb/s	x1.36	= W
Energy (J = Nm)				
kJ	x0.948	= Btu	x1.055	= kJ
J	x0.239	= calorie	x4.19	= J
Speed and acceleration				
m/s <sup>2</sup>	x3.28	= ft/s <sup>2</sup>	x0.305	= m/s <sup>2</sup>
m/s	x3.28	= ft/s	x0.305	= m/s
km/h	x0.62	= mph	x1.61	= km/h
Horsepower/torque				
Bhp x5252 rpm = TQ (lb-ft)			TQ x rpm 5252 = bhp	
Temperature				
$^{\circ}\text{C} = (^{\circ}\text{F} - 32) / 1.8$			$^{\circ}\text{F} = (^{\circ}\text{C} \times 1.8) + 32$	
Flow factor				
l/min (dm <sup>3</sup> /min)	x0.264	= US gal/min	x3.785	= liter/min

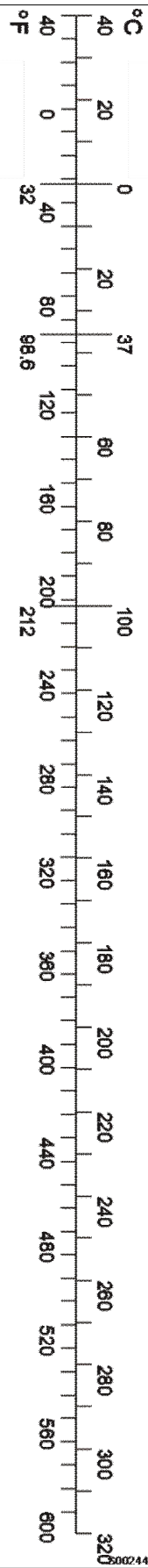

Document Title: <b>Torque wrench extension</b>	Function Group: <b>030</b>	Information Type: <b>Service Information</b>	Date: <b>4/19/2026</b>
Profile: <b>L90H Volvo</b>			

## Torque wrench extension

Showing Selected Profile

Valid for serial numbers			
Model	Production site	Serial number start	Serial number stop
L90H Volvo			

When an extension is used together with a torque wrench (e.g.88830381 Wrench), the torque applied to the screw increases since the lever arm is extended.

The following formula is used to calculate the correct torque wrench settings:

$$M1 = M2 \times (L1/L2)$$

**M1** is the torque to be set on the torque wrench.

**L1** is the normal length of the torque wrench.

**M2** is the tightening torque according to specification.

**L2** is the total length of the torque wrench and extension.

**NOTE!**

The extension and the torque wrench must be in a straight line for the calculation to be correct.

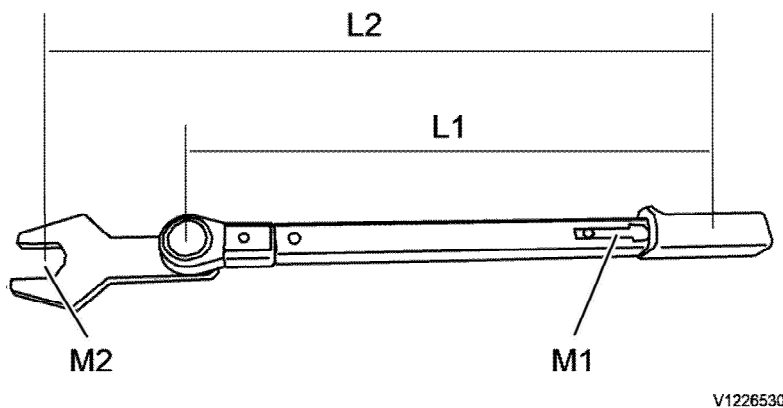

**Figure 1**

**Calculation example**

M1 is the torque to be set on the torque wrench.

M2 is the tightening torque according to specification, e.g. 100 Nm.

L1 is the measured length of the torque wrench, e.g. 45 cm.

L2 is the measured length of the extension and the torque wrench, e.g. 60 cm.

L1 = 45 cm

L2 = 60 cm

M2 = 100 Nm

$$M1 = 100 \text{ Nm} \times (45 \text{ cm}/60 \text{ cm}) = 75 \text{ Nm}$$

Document Title: <b>Operation numbers for additional work</b>	Function Group: <b>070</b>	Information Type: <b>Service Information</b>	Date: <b>4/19/2026</b>
Profile: <b>Wheel Loaders (WLO)</b>			

## Operation numbers for additional work

Showing Selected Profile

These operations can be used to identify work that is not included in the time guide or described in the methods in the Service Manual. When these operations are used, a description of the work that has been performed must be provided.

### Other work related to engine

Op. no. 070-210

This operation can be used when work has been done related to the engine and function group 2 when no applicable method description was available. When this operation is used, additional information is required:

- Description of work that has been done

### Other work related to electrical system

Op. no. 070-310

This operation can be used when work has been done related to the electrical system and function group 3 when no applicable method description was available. When this operation is used, additional information is required:

- Description of work that has been done

### Other work related to transmission, gearbox, travel motor, swing motor

Op. no. 070-410

This operation can be used when work has been done related to the transmission, gearbox, travel motor or swing motor and function group 4 when no applicable method description was available. When this operation is used, additional information is required:

- Description of work that has been done

### Other work related to drive axle

Op. no. 070-470

This operation can be used when work has been done related to the drive axle and function group 46 when no applicable method description was available. When this operation is used, additional information is required:

- Description of required work that have been done

### Other work related to brake system

Op. no. 070-510

This operation can be used when work has been done related to the brake system and function group 5 when no applicable

method description was available. When this operation is used, additional information is required:

- Description of work that has been done

**Other work related to steering system**

Op. no. 070-610

This operation can be used when work has been done related to the steering system and function group 6 when no applicable method description was available. When this operation is used, additional information is required:

- Description of work that has been done

**Other work related to frame link, axle suspension**

Op. no. 070-710

This operation can be used when work has been done related to the frame link, axle suspension and other parts related to function group 7 when no applicable method description was available. When this operation is used, additional information is required:

- Description of work that has been done

**Other work related to cab, air conditioning**

Op. no. 070-810

This operation can be used when work has been done related to the cab, air conditioning and other parts related to function group 8 when no applicable method description was available. When this operation is used, additional information is required:

- Description of work that has been done

**Other work related to hydraulic system**

Op. no. 070-910

This operation can be used when work has been done related to the hydraulic system and other parts related to function group 9 when no applicable method description was available. When this operation is used, additional information is required:

- Description of work that has been done

Document Title: <b>E1706</b>	Function Group: <b>080</b>	Information Type: <b>Service Information</b>	Date: <b>4/19/2026</b>
Profile: <b>L90H Volvo</b>			

### E1706

Showing Selected Profile

Valid for serial numbers			
Model	Production site	Serial number start	Serial number stop
L90H Volvo			

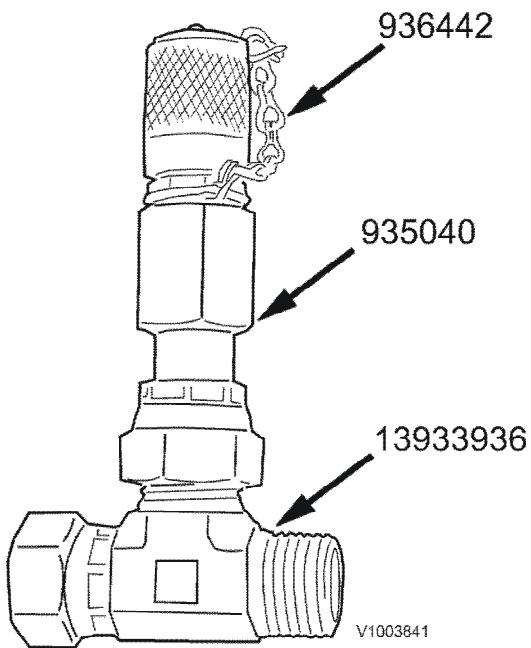

Figure 1

Document Title: <b>E 1708, Checking point</b>	Function Group: <b>080</b>	Information Type: <b>Service Information</b>	Date: <b>4/19/2026</b>
Profile: <b>L90H Volvo</b>			

### E 1708, Checking point

Showing Selected Profile

Valid for serial numbers			
Model	Production site	Serial number start	Serial number stop
L90H Volvo			

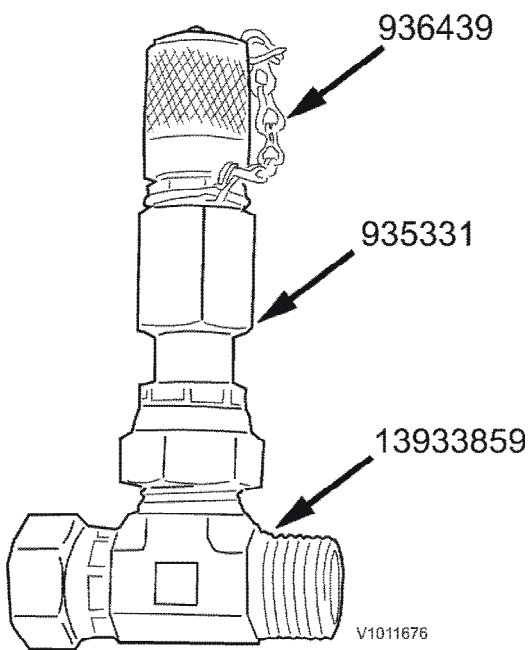

Figure 1

Document Title: <b>E1711</b>	Function Group: <b>080</b>	Information Type: <b>Service Information</b>	Date: <b>4/19/2026</b>
Profile: <b>L90H Volvo</b>			

### E1711

Showing Selected Profile

Valid for serial numbers			
Model	Production site	Serial number start	Serial number stop
L90H Volvo			

### E1711

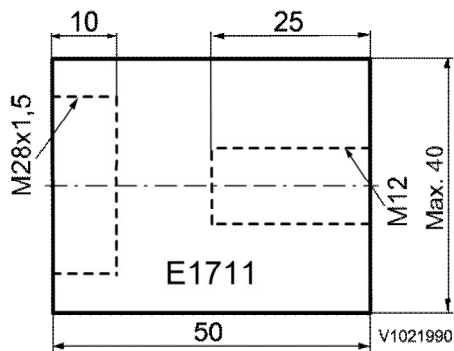

**Figure 1**

E1711

Document Title: <b>E-2001</b>	Function Group: <b>080</b>	Information Type: <b>Service Information</b>	Date: <b>4/19/2026</b>
Profile: <b>L90H Volvo</b>			

### E-2001

Showing Selected Profile

Valid for serial numbers			
Model	Production site	Serial number start	Serial number stop
L90H Volvo			

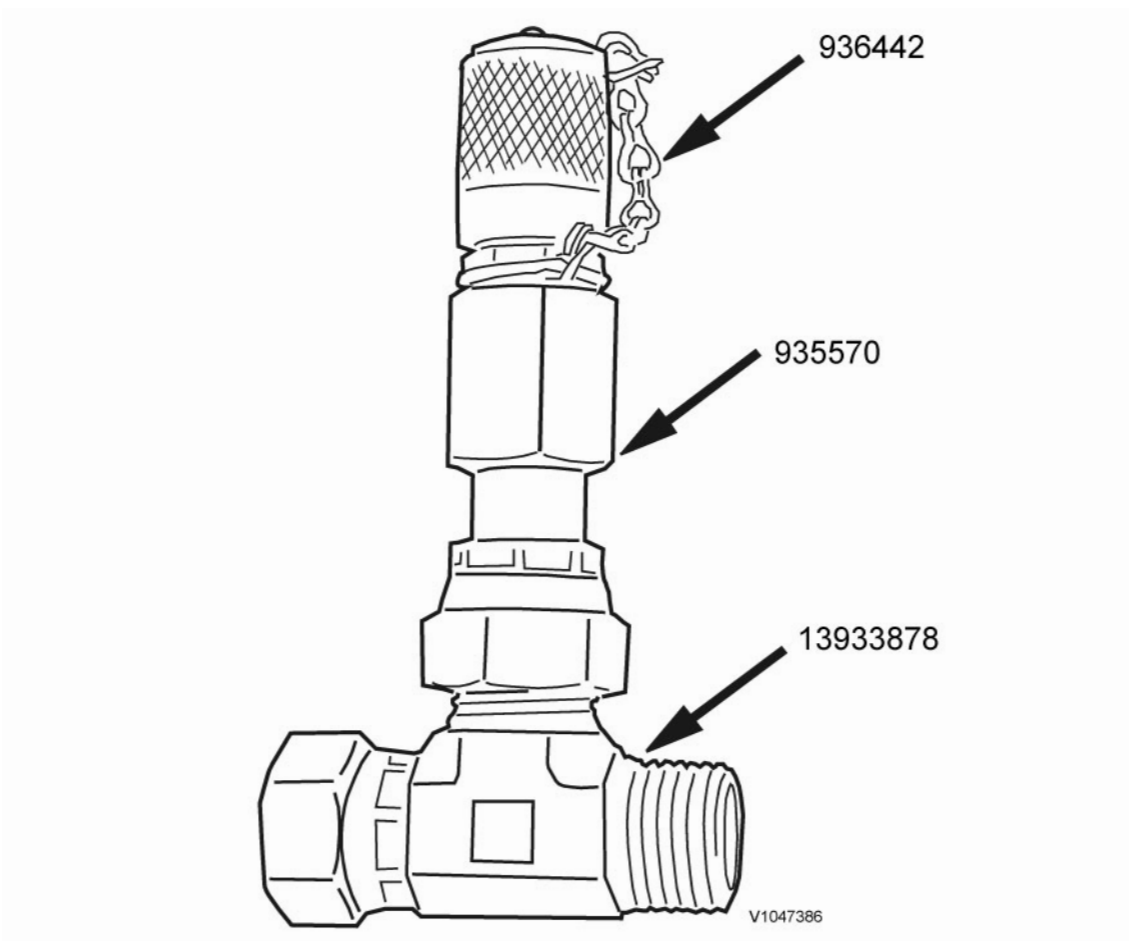

Figure 1

Document Title: <b>E-2005</b>	Function Group: <b>080</b>	Information Type: <b>Service Information</b>	Date: <b>4/19/2026</b>
Profile: <b>L90H Volvo</b>			

## E-2005

Showing Selected Profile

Valid for serial numbers			
Model	Production site	Serial number start	Serial number stop
L90H Volvo			

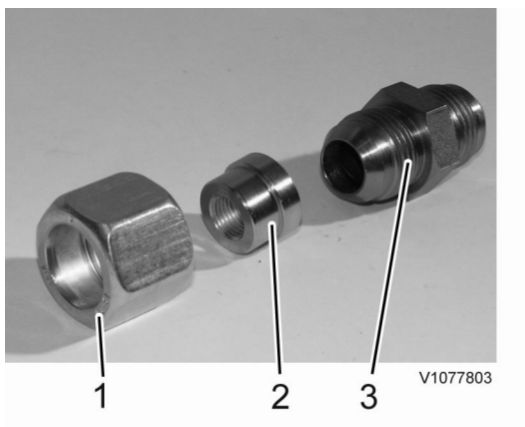

**Figure 1**

E-tool 2005

1. Coupling nut 931206
2. Test nipple 11054368 Thread R1/4"
3. Nipple 929315

Document Title: <b>E-2014</b>	Function Group: <b>080</b>	Information Type: <b>Service Information</b>	Date: <b>4/19/2026</b>
Profile: <b>L90H Volvo</b>			

### E-2014

Showing Selected Profile

Valid for serial numbers			
Model	Production site	Serial number start	Serial number stop
L90H Volvo			

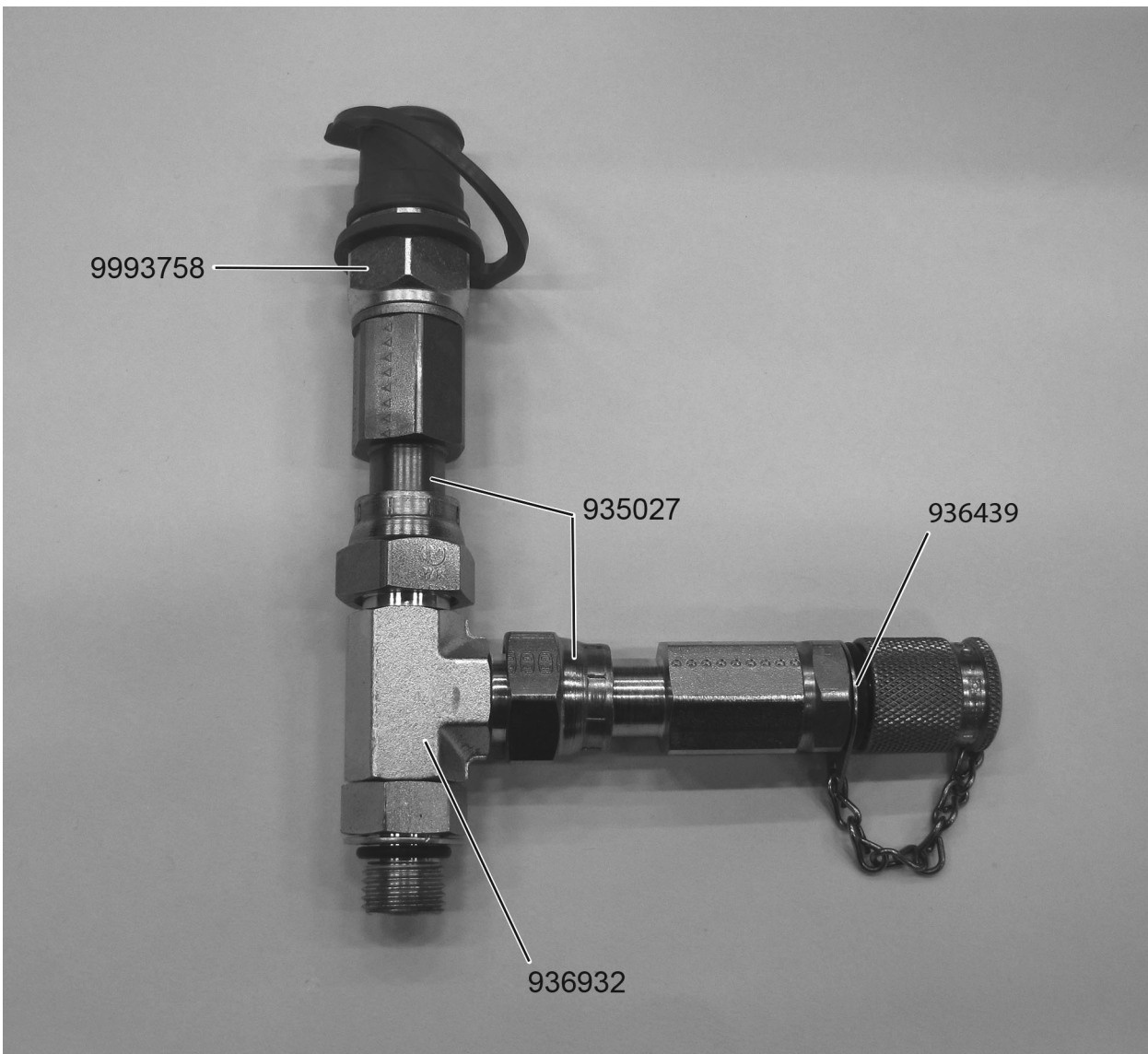

V1138633

Figure 1

Document Title: <b>E-2015</b>	Function Group: <b>080</b>	Information Type: <b>Service Information</b>	Date: <b>4/19/2026</b>
Profile: <b>L90H Volvo</b>			

### E-2015

Showing Selected Profile

Valid for serial numbers			
Model	Production site	Serial number start	Serial number stop
L90H Volvo			

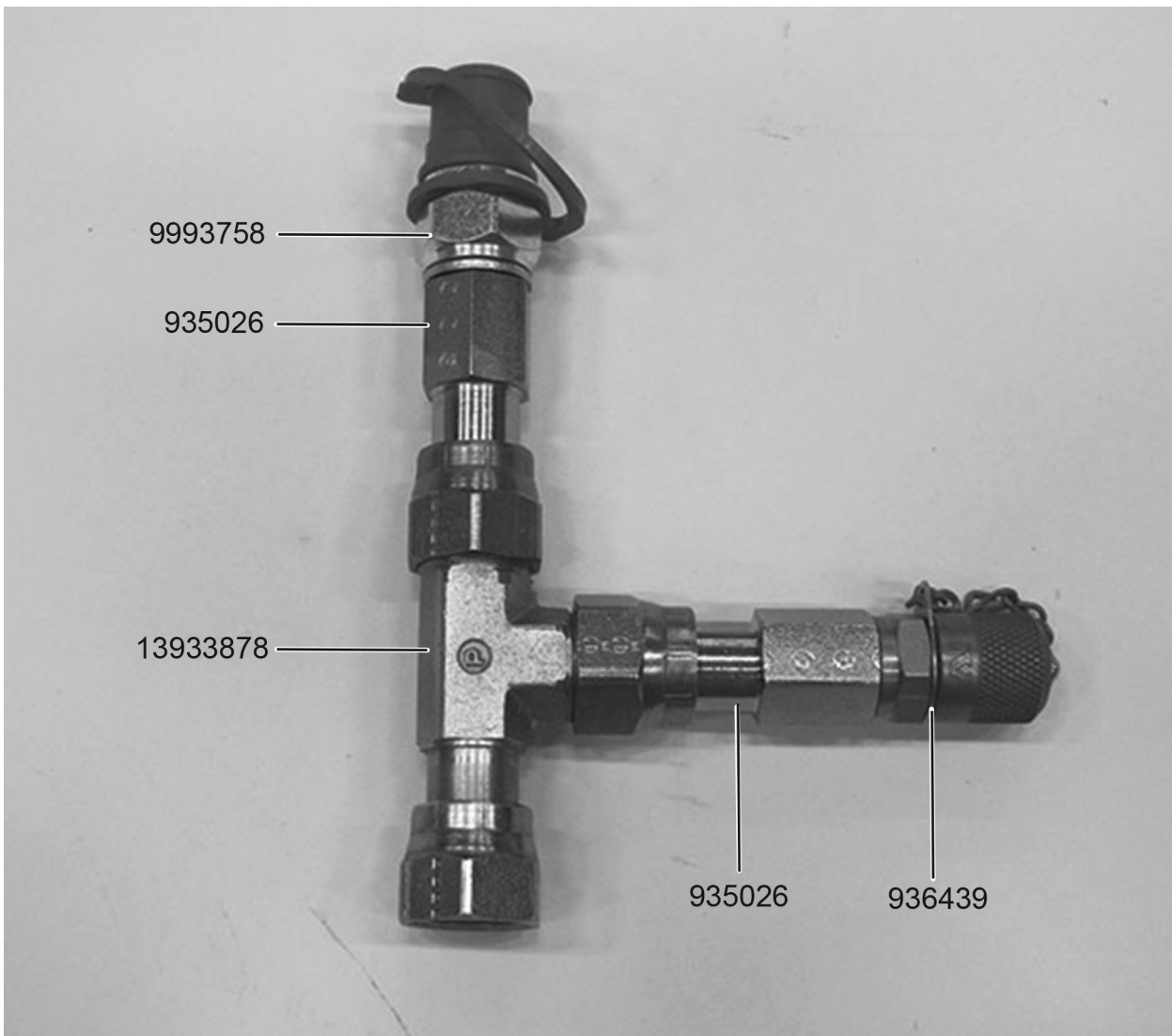

V1138746

Figure 1

Document Title: <b>E-2030</b>	Function Group: <b>080</b>	Information Type: <b>Service Information</b>	Date: <b>4/19/2026</b>
Profile: <b>L90H Volvo</b>			

### E-2030

Showing Selected Profile

Valid for serial numbers			
Model	Production site	Serial number start	Serial number stop
L90H Volvo			

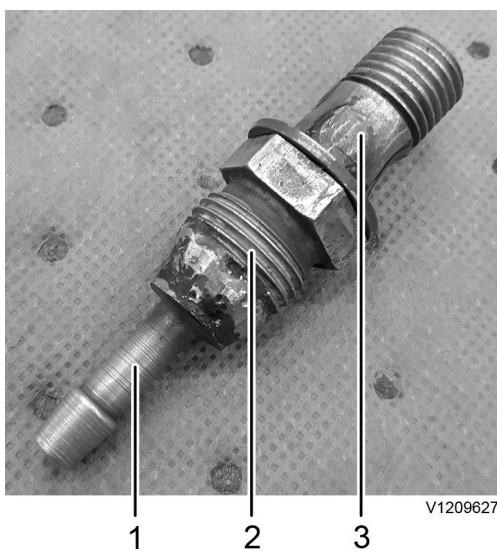

**Figure 1**

1. Hose nipple, diameter of approx. 8 mm
2. 21023622
3. Holes welded shut

Document Title: <b>E-2032</b>	Function Group: <b>080</b>	Information Type: <b>Service Information</b>	Date: <b>4/19/2026</b>
Profile: <b>L90H Volvo</b>			

### E-2032

Showing Selected Profile

Valid for serial numbers			
Model	Production site	Serial number start	Serial number stop
L90H Volvo			



**Figure 1**

1. 995895
2. Washers (2 pcs)

Document Title: <b>9993807 Lifting tool user instructions</b>	Function Group: <b>080</b>	Information Type: <b>Service Information</b>	Date: <b>4/19/2026</b>
Profile: <b>L90H Volvo</b>			

## 9993807 Lifting tool user instructions

Showing Selected Profile

Valid for serial numbers			
Model	Production site	Serial number start	Serial number stop
L90H Volvo			

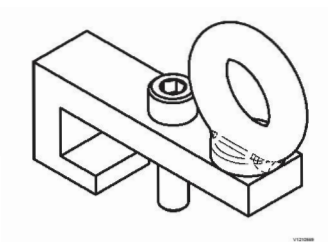

**Figure 1**

9993807 Lifting tool

### Instructions

This instruction is a guide on how to use and maintain the lifting tool correctly. The instructions must be studied carefully by the personnel concerned before the lifting tool can be put into use.

The instructions must always be available to the personnel maintaining and using the lifting tool daily.

### It is also important to:

- Keep the instructions and other applicable documents during the entire lifetime of the lifting tool.
- Pass the instructions to other owners or users of the lifting tool.
- Update the instructions with additions or changes made by the manufacturer.

Pay careful attention to information about warnings mentioned in the instructions and found on the warning signs on the lifting tools. If this information is not observed, severe personal injuries and equipment damage can arise.

### Responsibility

The instructions describe the authorized method to use the lifting tool.

The lifting tool may only be used by personnel with adequate technical training or corresponding professional experience and in consultation with the manufacturer.

If the instructions have not been followed, the manufacturer is not responsible for personal injuries or damage to equipment.

### Marking

Do not remove or make machine labels or other labels unreadable.

The lifting tool is marked with a CE mark, which means that it is designed, manufactured and described in accordance with EC Machinery Directive 2006/42/EC.

Warning decals and CE mark on lifting tool must be clearly visible. If a part provided with warning decals or CE mark is changed, a new warning decal and CE mark must be mounted in the same place. Defective decals and CE marks must be replaced immediately.



V1141218

## Figure 2

CE-marking

### Manufacturer

Company: Volvo Construction Equipment AB

Address: CE-46840, RLA 0301

Postal address: 631 85 Eskilstuna, Sweden

### Rebuilding

If the lifting tool is rebuilt or supplemented with other parts without permission by the manufacturer, the CE marking does not include this part. If such rebuilding or added parts changes the function of the lifting tool, the CE marking in its entirety is no longer valid. After rebuilding, it is important that the instructions are supplemented with the necessary illustrations, photos and texts.

### NOTE!

If not explicitly stated otherwise, always assume this instruction reference the use of two 9993807 Lifting tools.

### Intended usage

The lifting toll specified in this document is only intended for lifting torque converters with a maximum weight of 100 kg. Intended users are appointed and trained personnel, the lifting gear is not intended to be used by unauthorised or underage personnel.

To fulfil the requirements for intended use, the user must follow all instructions and maintenance directions written by the manufacturer.

### Technical data

Type designation: lifting tool for torque converter

Maximum load, lifting tool x 2: 100 kg (220 lb)

Mass, lifting tool x 2 with shackles and chain slings: 5 kg (11 lb)

Test factor for static testing (for lifting tools): 1.5

### Safety information

### Limits of use

The lifting tools may only be used for the intended purpose. All other use is forbidden.

Lifting hooks must be equipped with a self-locking hook.

Shackles should be used for connecting the tools.

Lifting sling and straps should be marked with lifting capacity.

All accessories for the lift must have sufficient lifting capacity.

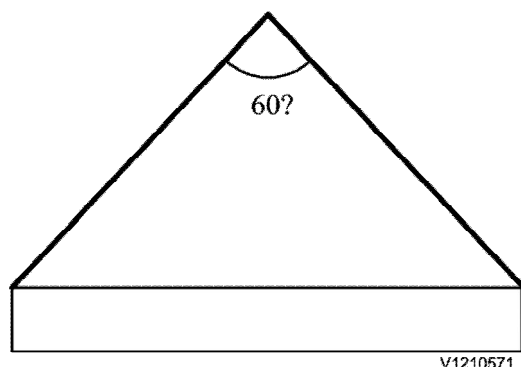

## Figure 3

Max lift-angle

Maximum lift angles must not exceed 60°.

### Handling

To meet the requirements for intended use, the user must observe all user and maintenance instructions prescribed by the manufacturer.

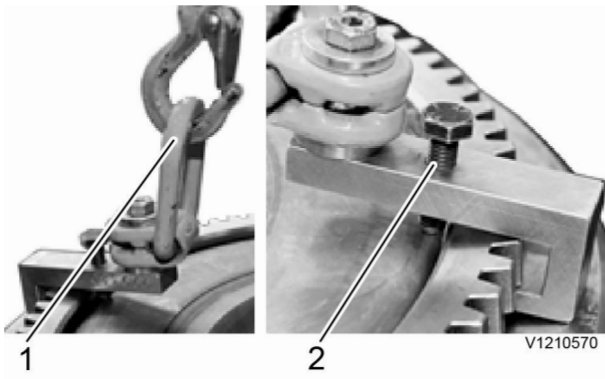

**Figure 4**

1. **Lifting equipment**  
 Use lifting sling with sufficient lifting capacity, 100 kg (220 lb).  
 Always use lifting hooks equipped with a self-locking hook.  
 Use shackles with sufficient lifting capacity, 100 kg (220 lb).
2. **Bolts**  
 Position the lifting tool under gear ring and tighten the bolts.  
 Tighten until the lifting tool is unable to move independently of the gear ring.

**Intended user**

The lifting device is intended to be used by trained personnel, it is not intended to be used by unauthorized or underage personnel.

**Conditions and preparatory measures**

Lifting tool with damaged parts must not be used.

Before lifting, check that the lifting tool does not have indications of cracks or deformations.

**Maintenance**

Maintenance must be performed by person with appropriate technical training or equivalent professional experience and in consultation with the manufacturer.

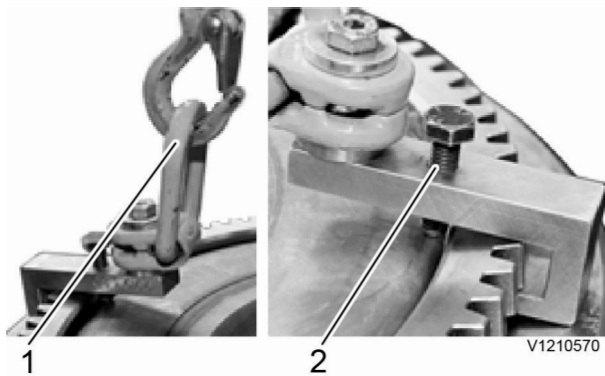

**Figure 5**

Detail/interval	Control/oversight
1 Shackles. Annual check.	Check that shackles does no have visible defects, cracks or deformations.
2 9993807 Lifting tool. Annual check.	Check that the lifting tool with threads and bolt does no have visible defects, cracks or deformations.

**General**

A defective lifting tool must be replaced.

**Workplace**

Protective shoes must be used.

The workplace should be kept free from equipment that can cause slipping or tripping risks.

The lifting tool is intended to be used in a workshop environment, outdoor usage is forbidden.

**Continuous supervision**

The lifting tool must be subjected to continuous supervision before use.

- Check for cracks.
- Check if the lifting tool is bent or deformed.
- Check that threaded screws and bolts are intact and do not have indications of breakage or deformation.

Document Title: <b>11668007 Lifting tool user instructions</b>	Function Group: <b>080</b>	Information Type: <b>Service Information</b>	Date: <b>4/19/2026</b>
Profile: <b>L90H Volvo</b>			

## 11668007 Lifting tool user instructions

Showing Selected Profile

Valid for serial numbers			
Model	Production site	Serial number start	Serial number stop
L90H Volvo			



V1210648

**Figure 1**  
11668007 lifting tool

**Instructions**

This instruction is a guide on how to use and maintain the lifting tool correctly. The instructions must be studied carefully by the personnel concerned before the lifting tool can be put into use.

The instructions must always be available to the personnel maintaining and using the lifting tool daily.

**It is also important to:**

- Keep the instructions and other applicable documents during the entire lifetime of the lifting tool.
- Pass the instructions to other owners or users of the lifting tool.
- Update the instructions with additions or changes made by the manufacturer.

Pay careful attention to information about warnings mentioned in the instructions and found on the warning signs on the lifting tools. If this information is not observed, severe personal injuries and equipment damage can arise.

**Responsibility**

The instructions describe the authorized method to use the lifting tool.

The lifting tool may only be used by personnel with adequate technical training or corresponding professional experience and in consultation with the manufacturer.

If the instructions have not been followed, the manufacturer is not responsible for personal injuries or damage to

equipment.

### Marking

Do not remove or make machine labels or other labels unreadable.

The lifting tool is marked with a CE mark, which means that it is designed, manufactured and described in accordance with EC Machinery Directive 2006/42/EC.

Warning decals and CE mark on lifting tool must be clearly visible. If a part provided with warning decals or CE mark is changed, a new warning decal and CE mark must be mounted in the same place. Defective decals and CE marks must be replaced immediately.

### Manufacturer

Company: BM Lindahl AB

Address: Älmedal 6

Postal address: 364 33 Åseda, Sweden

### Rebuilding

If the lifting tool is rebuilt or supplemented with other parts without permission by the manufacturer, the CE marking does not include this part. If such rebuilding or added parts changes the function of the lifting tool, the CE marking in its entirety is no longer valid. After rebuilding, it is important that the instructions are supplemented with the necessary illustrations, photos and texts.

### Intended usage

11668007 Lifting tool consists of stand, lifting jack, extensions and locking pins.

Intended users are appointed and trained personnel, the lifting tool is not intended to be used by unauthorized or underage personnel.

To fulfil the requirements for intended use, the user must follow all instructions and maintenance directions written by the manufacturer.

The lifting tool is only intended for lifting Volvo Wheel Loaders and Volvo Articulated Haulers. Maximum load: 15 000 kg (33 070 lb).

### Technical data

Type designation: lifting tool

Maximum load: 15 000 kg (33 070 lb), with two 11668007 lifting tools: 30 000 kg (66 140 lbs)

Mass: 78 kg (172 lb)

Test factor for static testing: For lifting tools and manually operated machines: 1.5. For other machines: 1.25

Height: 500–800 mm (19.7–31.5 in), with extensions: 600–900 mm (23.6–35.4 in)

### Safety information

#### Limits of use

The lifting tools may only be used for the intended purpose. All other use is forbidden.

For Volvo Wheel Loaders, the lifting tool is only intended to lift the rear axle.



V1071600

Always secured loads with safety pins. To stay under raised load without locking pins, is associated with life danger.



V1071600

To prevent breakage and sliding, the lifting tool must always be used with a vertical load.

To prevent oblique loads, always use two 11668007 lifting tools.

#### Handling

To meet the requirements for intended use, the user must observe all user and maintenance instructions prescribed by the manufacturer.

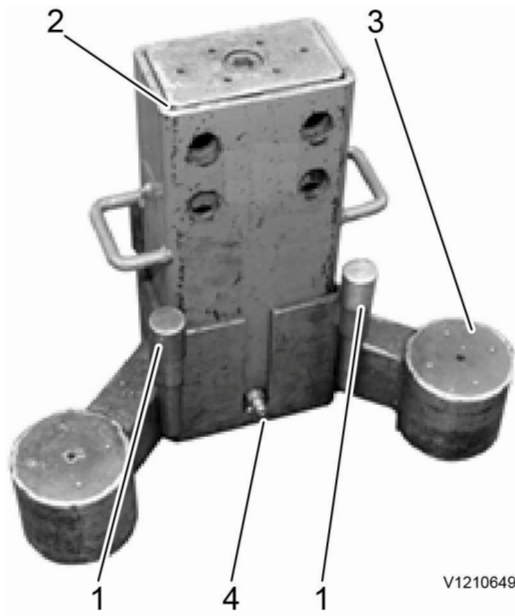

**Figure 2**

Pre use check

1. **Safety pins**  
Make sure that safety pins are supplied along with the lifting tool.  
Check that the safety pins are intact and do not have indications of breakage or deformation.
2. **Inner and outer lifting beam**  
Check that the beam with pin holes is intact and do not have indications of breakage or deformation.
3. **Support legs**  
The lifting tool has three support legs.  
Check that the stand is intact and does not have indications of breakage or deformation.
4. **Connection nipple**  
Connection nipple for pneumatic pump.

**Pneumatic pump**

Check that pneumatic pump with hose kit and couplings does not have indications of breakage or deformation. Always replace defective units.

**Intended user**

The lifting device is intended to be use by trained personnel, it is not intended to be used by unauthorized or underage personnel.

**Conditions and preparatory measures**

Lifting tool with damaged parts must not be used.



V1071600

Make sure that there are no people in the vicinity who may be at risk when operating this lifting tool.

**Lifting**



V1071600

Never stay under raised load with the safety pins disconnected.

1. **Steering linkage lock**  
Lock steering linkage with steering linkage lock.  
If an articulated hauler is being lifted, place body support.  
Connect stops.
2. **Assemble**  
Place the lifting jack into the stand.  
Make sure the nipple fits in the groove.
3. **Place the lifting tool**

Place the lifting tool under wheel axle lifting point.

If needed, connect extensions.

Connect pneumatic pump to the respective nipple on the lifting tools.

To ensure a parallel lift, lower the lifting tools to their lower end point.

Start the pneumatic pump (pumps) and lift to the desired level.

4. **Safety pins**

Connect all safety pins. Make sure that all safety pins are fully inserted.

Lower until the load rests on the safety pins.



**Figure 3**

### Lowering

1. **Steering linkage lock**

Remove steering linkage lock.

Remove stops.

2. **Remove safety pins**

Lift the load with the lifting tools to release the safety pins.

Remove all safety pins and place the safety pins at their designed holders on the lifting tools.

3. **Lower the load**

Lower the load.

Lower the lifting tools to their lower end point.

Make sure that the lifting tools are lowered parallel to avoid uneven weight distribution.

4. **Remove pump and lifting tool**

Disconnect the pneumatic pump (pumps) from the nipples on the lifting tools.

Remove the lifting tool and place it at the designated location.

### Maintenance

Maintenance must be performed by person with appropriate technical training or equivalent professional experience and in consultation with the manufacturer.

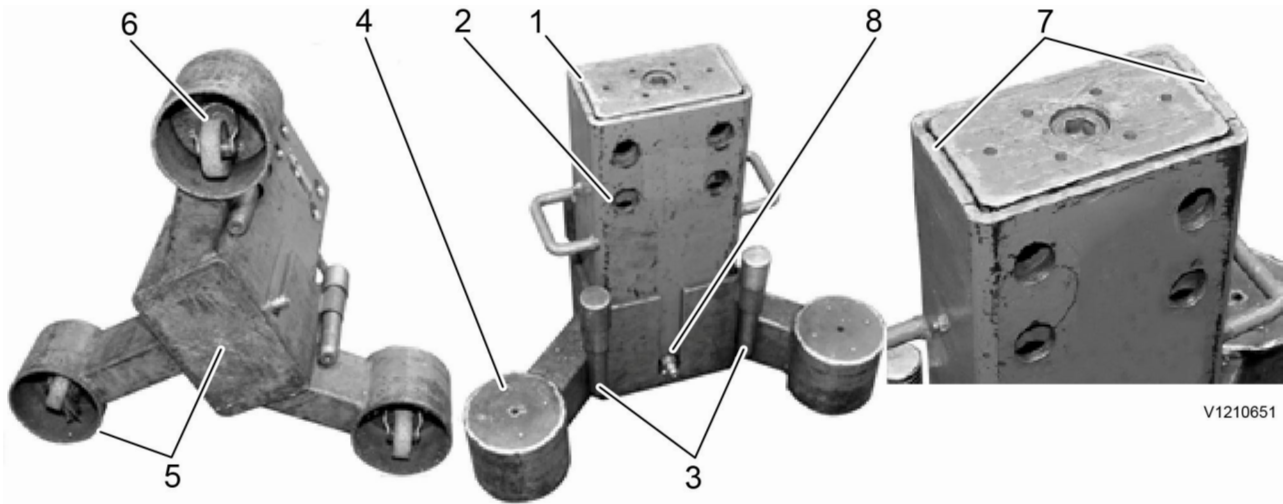

V1210651

**Figure 4**

<b>Detail/interval</b>	<b>Control/oversight</b>
<b>1. Inner and outer beam</b> Before use.	Check that beams are intact and does not have indications of breakage or deformation.
<b>2. Pin holes, inner and outer beam</b> Before use.	Check that all holes in beams are intact and does not have indications of breakage or deformation.
<b>3. Pins</b> Before use.	Check that all pins are intact and does not have indications of breakage or deformation. Before lifting, make sure that no pins are missing.
<b>4. Support legs</b> Before use.	Check that the support legs are intact and does not have indications of breakage or deformation.
<b>5. Supporting surfaces</b> Monthly check.	Check that all supporting areas are intact and does not have indications of breakage or deformation.
<b>6. Castor</b> As needed.	Replaced as needed.
<b>7. Friction plate</b> Annual check or as needed.	Lift the inner beam to its upper end point. Grease the friction plates and lower the beam to its lower end point to disperse the grease.
<b>8. Quick coupling</b> Before use.	Check that the quick coupling is clean. Clean dirty quick coupling with cloth. Protect quick coupling with plastic cover.

**General**

A defective lifting tool must be replaced.

**Workplace**

Protective shoes must be used.

The workplace should be kept free from equipment that can cause slipping or tripping risks.

The lifting tool is intended to be used in a workshop environment, outdoor usage is forbidden.

The lifting tool is intended to be used on a level and stable surface.

Leaked or spilled hydraulic oil should be taken care of immediately with an absorbent to prevent slipping. The supplier/ manufacturers product sheet regarding safe handling of hydraulic oil must be followed.

**Continuous supervision**

The lifting tool must be subjected to continuous supervision before use.

- Check for cracks.
- Check if the lifting tool is bent or deformed.
- Make sure that quick couplings are clean.

Document Title: <b>11668008 Lifting tool user instructions</b>	Function Group: <b>080</b>	Information Type: <b>Service Information</b>	Date: <b>4/19/2026</b>
Profile: <b>L90H Volvo</b>			

## 11668008 Lifting tool user instructions

Showing Selected Profile

Valid for serial numbers			
Model	Production site	Serial number start	Serial number stop
L90H Volvo			



V1210596

**Figure 1**  
11668008 lifting tool

### Instructions

This instruction is a guide on how to use and maintain the lifting tool correctly. The instructions must be studied carefully by the personnel concerned before the lifting tool can be put into use.

The instructions must always be available to the personnel maintaining and using the lifting tool daily.

### It is also important to:

- Keep the instructions and other applicable documents during the entire lifetime of the lifting tool.
- Pass the instructions to other owners or users of the lifting tool.
- Update the instructions with additions or changes made by the manufacturer.

Pay careful attention to information about warnings mentioned in the instructions and found on the warning signs on the lifting tools. If this information is not observed, severe personal injuries and equipment damage can arise.

### Responsibility

The instructions describe the authorized method to use the lifting tool.

The lifting tool may only be used by personnel with adequate technical training or corresponding professional experience and in consultation with the manufacturer.

If the instructions have not been followed, the manufacturer is not responsible for personal injuries or damage to equipment.

### Marking

Do not remove or make machine labels or other labels unreadable.

The lifting tool is marked with a CE mark, which means that it is designed, manufactured and described in accordance with EC Machinery Directive 2006/42/EC.

Warning decals and CE mark on lifting tool must be clearly visible. If a part provided with warning decals or CE mark is changed, a new warning decal and CE mark must be mounted in the same place. Defective decals and CE marks must be

replaced immediately.



V1141218

## Figure 2

CE-marking

### Manufacturer

Company: BM Lindahl AB

Address: Älmedal 6

Postal address: 364 33 Åseda, Sweden

### Rebuilding

If the lifting tool is rebuilt or supplemented with other parts without permission by the manufacturer, the CE marking does not include this part. If such rebuilding or added parts changes the function of the lifting tool, the CE marking in its entirety is no longer valid. After rebuilding, it is important that the instructions are supplemented with the necessary illustrations, photos and texts.

### Intended usage

11668008 lifting tool consists of stand, lifting jack, extensions and locking pins.

Intended users are appointed and trained personnel, the lifting tool is not intended to be used by unauthorized or underage personnel.

To fulfil the requirements for intended use, the user must follow all instructions and maintenance directions written by the manufacturer.

### Technical data

Type designation: lifting tool

Maximum load: 30 000 kg (66 140 lb)

Mass: 117 kg (257.9 lb)

Test factor for static testing: For lifting tools and manually operated machines: 1.5. For other machines: 1.25

Height: 500–800 mm (19.7–31.5 in), with extensions: 600–900 mm (23.6–35.4 in)

### Safety information

#### Limits of use

The lifting tools may only be used for the intended purpose. All other use is forbidden.

The lifting tool is only intended for lifting Volvo Wheel Loaders and Volvo Articulated Haulers. Maximum load: 30 000 kg (66 140 lb).

For Volvo Wheel Loaders, the lifting tool is only intended to lift the rear axle.



V1071600 Always secured loads with safety pins. To stay under raised load without locking pins, is associated with life danger.



V1071600 Make sure that there are no people in the vicinity who may be at risk when operating this lifting tool.

### Handling

To meet the requirements for intended use, the user must observe all user and maintenance instructions prescribed by the manufacturer.

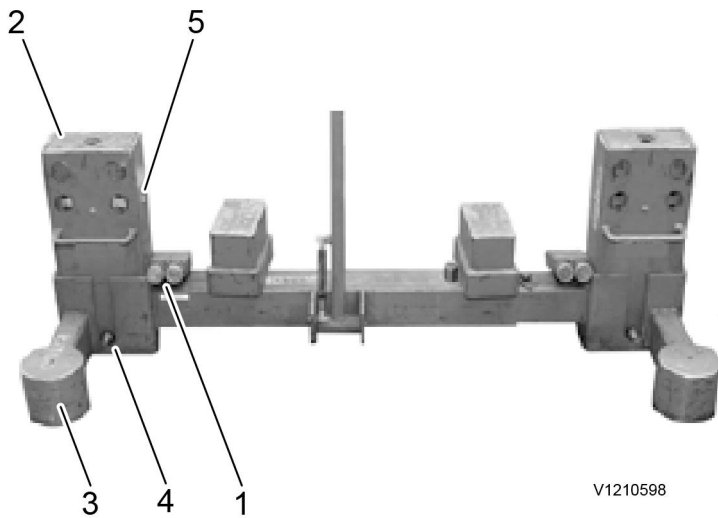

V1210598

**Figure 3**

Pre use check

1. **Safety pins**  
Make sure that safety pins are supplied along with the lifting tool.  
Check that safety pins are intact and do not have indications of breakage or deformation.
2. **Inner and outer lifting beam**  
Check that the beams with pin holes are intact and do not have indications of breakage or deformation.
3. **Support legs**  
The lifting tool with double stand has four support legs.  
Check that the stand is intact and does not have indications of breakage or deformation.
4. **Connection nipple**  
Connection nipple for pneumatic pump.
5. **Mounting point**  
Mounting point for friction plate, 4 per unit.

**Pneumatic pump**

Check that pneumatic pump with hose kit and couplings does not have indications of breakage or deformation. Always replace defective units.

**Adjust width**

Adjust the lifting tool to fit the axle lifting points.

**Intended user**

The lifting device is intended to be used by trained personnel, it is not intended to be used by unauthorized or underage personnel.

**Conditions and preparatory measures**

Lifting tool with damaged parts must not be used.

**Lifting**



V1071600 Never stay under a raised load with the safety pins disconnected.

1. **Steering linkage lock**  
Lock steering linkage with steering linkage lock.  
If an articulated hauler is being lifted, place body support.  
Connect stops.
2. **Place the lifting tool**  
Place the lifting tool under wheel axle lifting points.  
If needed, connect extensions.  
Connect pneumatic pump to the respective nipple on the lifting tool.  
To ensure a parallel lift, lower the lifting tool to its lower end point.  
Start the pneumatic pump and lift to the desired level.

3. **Safety pins**

Connect all safety pins. Make sure that all safety pins are fully inserted.  
Lower until the load rests on the safety pins.

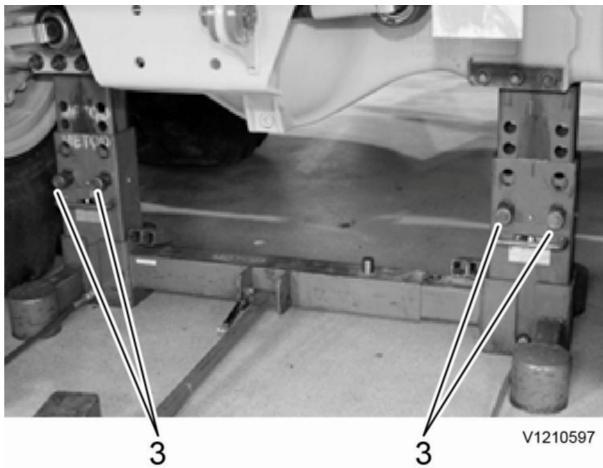

**Figure 4**

### Lowering

1. **Steering linkage lock**  
Remove steering linkage lock.  
Remove stops.
2. **Remove safety pins**  
Lift the load with the lifting tool to release the safety pins.  
Remove all safety pins and place the safety pins at their designed holders on the lifting tool.
3. **Lower the load**  
Lower the load.  
Lower the lifting tool to its lower end point.  
Make sure that the lifting tool is lowered parallel to avoid uneven weight distribution.
4. **Remove pump and lifting tool**  
Disconnect the pneumatic pump from the nipples on the lifting tool.  
Remove the lifting tool and place it at the designated location.

### Maintenance

Maintenance must be performed by person with appropriate technical training or equivalent professional experience and in consultation with the manufacturer.