

Document Title: Description	Function Group: 000	Information Type: Service Information	Date: 4/19/2026
Profile:			

Description

The machine is a four-wheel drive loader with articulated frame steering.

The engine is a six-cylinder, four-stroke, direct-injection, turbocharged, diesel engine with the designation TD63KBE (L90C), TD73KDE (L120C).

The transmission is hydro-mechanical of the power shift type, where all gears are in constant mesh, with the designation HT131 for L90C and HT205 for L120C.

Between the engine and the transmission there is a single stage hydraulic torque converter.

Front and rear axles have fully floating drive shafts with planetary type gears in the hubs. The front axle is provided with a differential lock.

The service brakes are wet type disc brakes, built integrally with the planetary gear in each wheel hub. The parking brake on L90C is of the disc brake type and it is positioned externally on the transmission output shaft. The parking brake on L120C is of the wet type disc brake and positioned inside the transmission on the output shaft.

The steering system is hydrostatic with a variable axial piston pump and two hydraulic cylinders (steering cylinders).

For further description of function and components, see the respective sections.



Figure 1

Loader L90C / L120C

Document Title: Product identification plates	Function Group: 000	Information Type: Service Information	Date: 4/19/2026
Profile:			

Product identification plates

The illustration below shows which plates should be fitted on the machine and where they are positioned.

When ordering spare parts and in all enquiries by telephone or correspondence, the model designation and Product Identification Number, (PIN) should be stated.

When applicable, any information on the additional plate, "INCL. PARTS" should be stated.

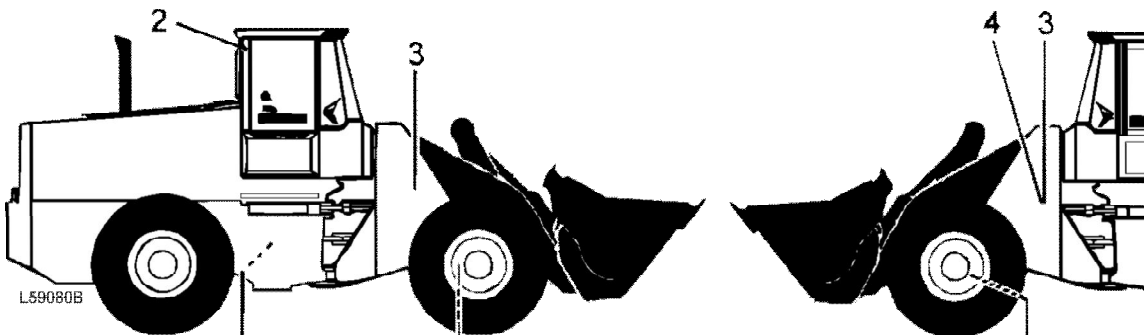

Figure 1

Product identification plates

1. Engine type designation, part and serial numbers are stamped into the side of the cylinder block (left side of machine)
2. Cab type, type approval and serial number are positioned by the right roof post inside the cab.
3. Product plate with Product Identification Number, PIN for the complete machine (shows model designation, engine manufacturer and serial number). The plate is fitted on the left side of the front frame. Model designation and serial number are also visibly stamped-in on the right side of the front frame.
4. Additional plate to product plate, which shows machine weight, engine output, year of manufacture and has a space for the CE mark (only EU/EEA countries), is positioned below the product plate.
5. Rear drive axle product and serial numbers are positioned on the right side of the axle housing.
6. Transmission product and serial numbers are positioned on the right side of the transmission.
7. Front drive axle product and serial numbers are positioned on the axle housing (above the differential lock connector).
8. Component plate with Component Identification Number, CIN for differential carrier assembly is positioned on the lower part of the differential casing.

Document Title: Volvo standard tightening torques	Function Group: 030	Information Type: Service Information	Date: 4/19/2026
Profile:			

Volvo standard tightening torques

The tightening torques in the following tables apply to bolts with a tensile strength as shown below. The tables are to be considered as a general instruction for the tightening torque of nuts and bolts unless otherwise stated.

NOTE!

For flange head bolts type U6FS the values should be increased by 10 %. Nuts and bolts must be cleaned and lubricated with oil.

TENSILE STRENGTH 8.8 Metric coarse and fine threads

Threads	N m	kgf m	lbf ft
M6	10 ±2	1.0 ±0.2	7.4 ±3.5
M8	24 ±5	2.4 ±0.5	18 ±3.5
M10	48 ±10	4.8 ±1.0	35 ±7.4
M12	85 ±18	8.5 ±1.8	63 ±13.0
M14	140 ±25	14.0 ±2.5	103 ±18.0
M16	220 ±45	22.0 ±4.5	160 ±33.0
M20	430 ±85	43.0 ±8.5	320 ±63.0
M24	740 ±150	74.0 ±15.0	550 ±110.0

TENSILE STRENGTH 10.9 Metric coarse and fine threads

Threads	N m	kgf m	lbf ft
M6	12 ±2	1.2 ±0.2	9 ±1.5
M8	30 ±5	3.0 ±0.5	22 ±3.5
M10	60 ±10	6.0 ±1.0	44 ±7.5
M12	105 ±20	10.5 ±2.0	78 ±14.5
M14	175 ±30	17.5 ±3.0	130 ±22
M16	275 ±45	27.5 ±4.5	204 ±33
M20	540 ±90	54.0 ±9.0	400 ±66
M24	805 ±160	80.5 ±16.0	594 ±118

UNC threads, coarse pitch

Threads	N m	kgf m	lbf ft
1/4"	9 ±2	0.9 ±0.2	6.6 ±1.5
5/16"	18 ±4	1.8 ±0.4	13 ±3.0
3/8"	33 ±8	3.3 ±0.8	24 ±5.9
7/16"	54 ±14	5.4 ±1.4	40 ±10
1/2"	80 ±20	8.0 ±2.0	59 ±15
9/16"	120 ±30	12.0 ±3.0	89 ±22
5/8"	170 ±40	17.0 ±4.0	130 ±30
3/4"	300 ±70	30.0 ±7.0	220 ±52

7/8"	485 ±115	48.5 ±11.5	360 ±85
1"	725 ±175	72.5 ±17.5	530 ±130

Document Title: Time Guide	Function Group: 070	Information Type: Service Information	Date: 4/19/2026
Profile:			

Time Guide

Regarding: L90C

16 Lubricants, fuels and other liquids

Op.no.	Time (h)	Operation
16234	1,75	Hydraulic oil tank, changing oil and filter excl. cleaning tank
16236	2,5	Hydraulic oil tank, changing oil and filter incl. cleaning tank
16238	1,5	Transmission, changing oil and filter and cleaning suction strainer
16259	1,5	Axles, changing oil

17 General

17101	0,5	Arrival inspection, according to programme
17102	1,5	Delivery inspection, according to programme
17202	3,5	Warranty inspection 100 hours, according to service programme
17204	8	Warranty inspection 1000 hours, according to service programme
17307	1,5	Maintenance service, every 250 hours
17310	3	Maintenance service, every 500 hours
17312	5	Maintenance service, every 1000 hours
17314	8	Maintenance service, every 2000 hours

21 Engine, general

21002	1,75	Compression test, engine at operating temperature
21070	5,5	Engine, removing
21071	40	Engine removed, general overhaul
21072	6	Engine, fitting
21102	8	Cylinder head, replacing gasket
21118	10	Cylinder heads all, replacing gaskets
21168	4	Cylinder heads all removed, decarbonizing and grinding in valves
21171	0,5	Cylinder head removed, pressure testing each
21180	4,5	Cylinder heads all, removing
21182	7	Cylinder heads all, fitting
21207	4	Cylinder block, liners removed, milling of all liner locations

21211	0,5	Cylinder, cylinder heads removed, measuring wear in all cylinders
21310	14	Cylinder liner and piston, replacing one
21318	24	Cylinder liners and pistons, replacing all
21412	1,5	Valves, adjusting
21421	0,25	Valve cover, fitting new gasket each
21427	0,5	Inspection cover, fitting new gasket
21430	14	Valves, decarbonizing and grinding
21436	0,5	Valve covers all, fitting new gasket
21493	4	Rocker arm mechanism removed, reconditioning
21502	6	Timing gear cover, fitting new gasket in machine
21530	6,5	Timing gear, replacing in machine
21532	8	Timing gear case, fitting new gasket in machine
21614	2,5	Crankshaft, replacing front oil seal
21618	12	Crankshaft, replacing rear oil seal
21640	14	Flywheel housing and sump gasket, replacing
21702	5	Sump gasket, replacing incl cleaning oil strainer

22 Lubrication and oil system

22106	0,25	Oil pressure relief valve, replacing
22114	6	Oil pump, replacing
22306	1,5	Oil cooler, replacing

23 Fuel system, general

23301	0,25	Fuel system, bleeding
23302	0,75	Feed pump, replacing
23304	0,5	Feed pump, checking feed pressure
23307	0,25	Feed pump, cleaning glass bowl and strainer
23314	5	Fuel filters all, replacing
23315	0,25	Fuel filter extra, replacing
23397	0,25	Feed pump removed, reconditioning
23410	3	Fuel tank, replacing
23601	0,5	Idling speed, checking and adjusting
23602	0,5	Stall speed, checking
23630	1,5	Injection timing, checking and adjusting
23644	1	Injection timing, checking
23673	2	Injection pump, replacing incl setting injection timing
23702	1,5	Injectors, replacing all
23704	0,75	Injector, replacing one
23707	0,25	Overflow valve, replacing
23716	1,5	Injectors, replacing copper sleeve in machine
23718	0,5	Delivery pipe, replacing one

23720	0,5	Pressure equalizer, replacing
23780	2	Injectors removed, reconditioning all

25 Inlet and exhaust systems

25102	1	Induction manifold, replacing gasket
25104	2	Exhaust manifold, replacing gasket
25220	1,5	Silencer, replacing
25221	0,5	Exhaust pipe, flexible tube, replacing
25571	1	Turbo charger, replacing
25573	2	Turbo charger removed, reconditioning
25601	0,5	Air cleaner, cleaning filter element
25602	0,25	Air cleaner, checking prssure drop indicator
25603	0,25	Air cleaner, primary filter replacing
25604	0,25	Air cleaner, secondary filter replacing
25606	0,75	Pre-heating coil, replacing

26 Cooling system

26104	1	Coolant, changing
26108	3	Radiator, replacing
26112	1	Radiator hose upper, replacing
26114	1	Radiator hoses lower, replacing
26202	1,5	Coolant pump, replacing
26271	1,5	Coolant pump removed, reconditioning
26298	1	Thermostat, replacing
26312	0,75	Fan belt and/or alternator belt, replacing
26322	1	Fan belt and/or alternator-, compressor belt, replacing all belts

27 Engine control

27321	0,75	Stop magnet, replacing
27323	0,5	Electrical engine shut down, check and adjusting

31 Battery and mounting parts

31102	1	Batteries, replacing
31103	0,5	Main switch, replacing
31106	0,5	Earth lead to battery, replacing
31108	1	Starter motor lead to battery, replacing

32 Alternator and charge regulator

32102	1	Alternator, replacing incl function check (no measuring instrument)
32125	0,5	Alternator, replacing carbon brush kit in machine
32205	0,5	Charging regulator, replacing

33 Starting system, general

33118	0,75	Starter motor, replacing
33401	0,5	Starter lock, replacing

35 Lighting

35224	0,5	Head lamp assy, replacing one incl adjusting
35316	0,5	Rear lamp, replacing one
35318	0,25	Rear lamp, replacing glass or bulb
35656	0,5	Work lighting, replacing one head lamp assy
35657	0,5	Work lighting, replacing one insert

36 Other electrical equipment, general

36102	0,25	Flasher unit, replacing relay
36110	0,75	Flasher switch, replacing
36117	0,25	Flasher lamp, replacing glass or bulb
36202	0,25	Horn, replacing
36203	0,5	Reverse alarm, replacing
36216	0,75	Horn switch, replacing
36301	0,5	Windscreen wiper rear, replacing motor
36302	0,75	Windscreen wiper front, replacing motor
36303	0,75	Windscreen wiper, replacing switch
36404	0,25	Switch, replacing
36408	0,25	Brake light switch, replacing
36720	0,5	ECU, replacing
36721	0,5	CU 8, replacing

37 Cables and fuses, general

37201	1	Printed circuit board, replacing
-------	---	----------------------------------

38 Instruments, sender units, warning systems

38603	0,5	Transmission oil pressure sensor, replacing
38604	0,5	Transmission temperature sensor, replacing
38605	0,5	Transmission, revolution sensor, replacing
38606	0,5	Engine temperature sensor, replacing
38607	0,5	Engine oil pressure sensor, replacing
38611	0,75	Fuel level sender, replacing
38704	0,5	Transmission temperature gauge, replacing
38705	0,5	Information display, replacing
38706	0,5	Engine temperature gauge, replacing
38711	0,5	Fuel level gauge, replacing
38720	0,5	Tachometer, replacing

39 Other equipment, e.g. radio and voltage conv.

39301	0,5	Voltage converter, replacing
-------	-----	------------------------------

42 Transmission, general

42102	0,75	Hydraulic transmission, check oil pressure
42104	2	Oil pump, replacing
42106	1,5	Oil cooler, replacing
42108	3	Gear selector valve, replacing
42109	1	Gear selector valve removed, reconditioning
42118	16	Converter, replacing
42123	1	Lubrication and converter pressure valve, replacing
42141	1	Oil distributor and seals, replacing f and r or 1:st and f or 3:rd and f
42142	2	Oil distributor and seals, replacing 1st and 2nd or 2nd and reverse
42143	3	Oil distributor and seals, replacing 3rd and 4th or 4th and reverse
42147	0,75	Gear selector, replacing
42148	0,75	Gear selector valve, replacing one solenoid
42154	1	Seal for rear output shaft, replacing
42171	40	Transmission removed, reconditioning
42173	9	Transmission, removing (together with engine)
42174	10	Transmission, fitting (together with engine)

43 Gearbox, mechanical

43402	2	Dropbox, replacing seal for front output shaft
43404	1	Dropbox, replacing seal for rear output shaft
43429	4	Dropbox removed, reconditioning
43473	4	Dropbox, fitting
43474	4	Dropbox, removing

45 Propeller shaft incl. bearings and mounting

45101	0,25	Propeller shaft and intermediate bearing, checking radial clearance
45102	2	Support or intermediate bearing, replacing
45104	1,5	Propeller shaft, rear, replacing
45107	1,5	Propeller shaft, in frame joint, replacing
45110	2	Propeller shaft, front, replacing

46 Drive axles, general

461	Null	Front axle
46101	4	Axle, replacing
46111	5	Centre gear , removing and fitting
46112	6	Centre gear removed, reconditioning
46114	2	Pinion front, fitting new gasket
46142	6	Hub retainer, reconditioning one side
46143	4	Hub, replacing seal
46151	6	Differential lock, replacing selector fork and clutch sleeves and adjusting
46152	0,25	Differential lock front, repacking excl adjusting
46153	1	Differential lock, adjusting engagement
463	Null	Rear axle
46301	8	Axle, replacing
46311	8	Centre gear, removing and fitting
46312	6	Centre gear removed, reconditioning
46314	2	Pinion rear, fitting new gasket
46342	6	Hub retainer, reconditioning one side
46343	4	Hub, replacing seal

51 Wheel brake, all

516	Null	Front axle
51601	0,5	Brake linings, checking wear
51604	4	Brake discs, replacing on both sides
51650	3	Brake piston, replacing seals
517	Null	Rear axle
51701	0,5	Brake linings, checking wear
51704	4	Brake disc, replacing both sides
51750	3	Brake piston, replacing seals

52 Hydraulic brake system

52001	0,5	Brake system, checking function, hydraulic
52002	0,5	Brake system, checking function, retardation
52004	0,5	Brake system, adjusting unloading pressure
52005	0,5	Brake system, check and adjusting pressure in circuit
52037	1	Brake system, bleeding
52509	1,25	Foot brake valve removed, reconditioning
52701	0,5	Accumulator removed, checking charging pressure
52702	0,5	Accumulator, replacing
52704	2	Hydraulic pump, replacing

55 Parking brake incl.control system

55002	0,5	Parking brake, adjusting
-------	-----	--------------------------

55004	1,5	Parking brake mechanical, replacing brake caliper
55005	3	Parking brake, replacing brake disc
55014	1,5	Parking brake, replacing brake pads

64 Steering

64121	1,5	Adjustable steering column, replacing
64503	0,25	Steering system, checking working pressure
64506	1,75	Steering cylinder, replacing
64510	2	Hydraulic pump, replacing
64515	0,5	Steering system, checking and adjusting standby pressure
64520	3	Steering system, checking and adjusting shock and anti-cavitation-
64521	1,5	Valve block, replacing
64528	0,75	Steering system, checking and adjusting working pressure
64554	2	Steering cylinder, replacing link bearings
64560	3	Steering cylinder, repacking in machine
64571	2,5	Hydraulic pump, replacing
64573	2	Hydraulic pump removed ,reconditioning
64577	1,75	Steering cylinder removed, reconditioning incl replacing bearings
64581	1,5	Steering valve removed, reconditioning
64582	2	Steering valve, replacing
64793	1	Auxiliary steering, replacing hydraulic pump

74 Frame joint, general

74105	0,5	Frame joint, checking clearance
74136	12	Frame joint, replacing bearings

75 Axle suspension, general

75501	0,75	Axle suspension, measuring axial and radial clearanse
75502	1	Axle suspension, adjusting axial clearance

77 Wheel, Tyre, Hub, Crawler/Track

77101	0,75	Wheel, removing and fitting
-------	------	-----------------------------

81 Cab, general

81815	1,75	Cab suspension, rubber element replacing
-------	------	--

83 Doors and Covers

83104	1,5	Door, replacing
83106	0,75	Door lock, replacing
83114	0,5	Door, replacing sealing strip

84 Outside trim parts, Glass, Sealing, Mouldings

84302	6	Windscreen, replacing
84312	1	Rear window, replacing
84313	1	Side window, replacing
84348	1	Door window, replacing

87 Air Conditioning unit

87201	0,25	Cab filter, replacing
87304	1	Radiator, replacing
87306	1	Fan motor, replacing
87308	0,75	Heat control valve, replacing
87309	0,75	Heat control, replacing
87402	1	Refrigerant, draining
87403	1	Cooling unit, performance test
87405	1,75	Refrigerant, filling excl vacuum pumping
87406	4	Compressor, replacing incl draining and filling
87407	1	V-belt, replacing
87411	3	Receiver, replacing incl draining and filling
87412	4	Evaporator, replacing incl draining and filling
87413	3,5	Expansion valve, replacing incl draining and filling
87414	1	Thermostat, replacing
87415	1	Compressor, replacing shaft seal (compressor removed)
87416	1	Compressor, replacing magnetic clutch (compressor removed)
87417	1,75	Compressor, replacing magnetic clutch in machine
87419	0,5	Compressor, replacing valve plate (compressor removed)

91 Working hydraulic and servo system

91105	2	Hydraulic tank, replacing inlet hose for pump
91111	2	Oil cooler, replacing
91138	5	Hydraulic oil tank, replacing
91201	5	Control valve, replacing
91202	4	Control valve removed, reconditioning
91204	0,75	Control valve, low pressure valve, replacing
91209	0,5	Shock valve, tilt function, checking and adjusting

91211	0,75	Shock valve lift function, adjusting
91302	1	Oil pump, checking and adjusting unloading pressure
91304	1	Oil pump, checking and adjusting working pressure
91310	3	Oil pump, replacing
91311	1	Oil pump removed, reconditioning
91454	0,5	Servo valve, adjusting control
91455	0,5	Servo pressure, checking and adjusting
91457	0,5	Servo pressure, check
91458	3	Servo valve, replacing
91460	2	Servo pump, replacing
91462	0,5	Pressure limiting valve, replacing
91463	0,75	Servo pressure, checking by spool valve in control valve
91475	2	Servo valve removed, reconditioning
91601	0,5	Boom suspension system, checking function
91602	0,75	Accumulator, check and adjusting
91603	1	Accumulator, reconditioning
91604	1,5	Boom suspension system, checking closing pressure
91605	1	Boom suspension system, checking opening pressure

94 Unit for load handling

94502	2	Lift frame, replacing bearing in lower bucket- or implement attachment
94503	0,25	Implement attachment, measuring clearance of lower bearing
94504	4	Lift cylinder, replacing
94505	4	Lift cylinder, repacking in machine
94506	3	Lift cylinder removed, repacking
94508	2	Tilt cylinder, replacing
94509	4	Tilt cylinder, repacking in machine
94510	3	Tilt cylinder removed, repacking
94511	1	Implemental attachment, replacing hydraulic cylinder
94516	4	Lift frame, replacing bearing in upper mounting "O"
94524	3	Tilt cylinder, replacing bearing in machine "E-F"
94545	2,5	Implemental attachment/bucket attachment, replacing bushes "A"
94554	1	Implement attachment, replacing
94562	2	T-link upper, replacing "HIJ"
94563	0,75	T-link upper removed, replacing bearings "HIJ"
94564	1	T-link, lower, replacing "IB"
94566	2,5	Tilt link, replacing "GH"
94567	0,75	Tilt link removed, replacing bearings

		"GH"
94568	3	Tilt arm, replacing bearing "GDF"
94569	2	Tilt arm, replacing "GDF"

Document Title: Section 4 Power transmission	Function Group: 080	Information Type: Service Information	Date: 4/19/2026
Profile:			

Section 4 Power transmission

E 985, Hose

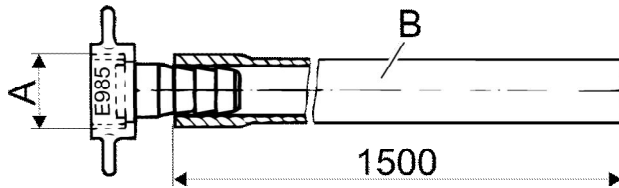

Figure 1

E 985

- A. Hose coupling \varnothing 1/2" BSP
- B. PVC-hose, 1/2"

Document Title: Section 5 Brakes	Function Group: 080	Information Type: Service Information	Date: 4/19/2026
Profile:			

Section 5 Brakes

E 1234, Nipple

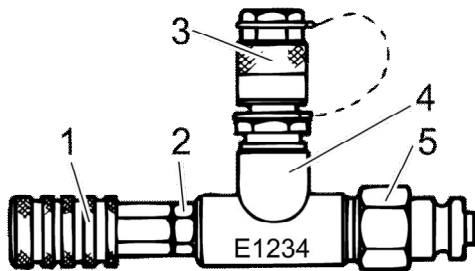

Figure 1

E 1234

1. 999 3522-3
2. Standard pipe bushing, 1/4" - R 1/8" BSP
3. Measuring nipple, part No. 930032
4. Standard T-pipe, 1/4" BSP
5. Nipple according to available pump. e.g. 999 3070B

E 1281 Nipple

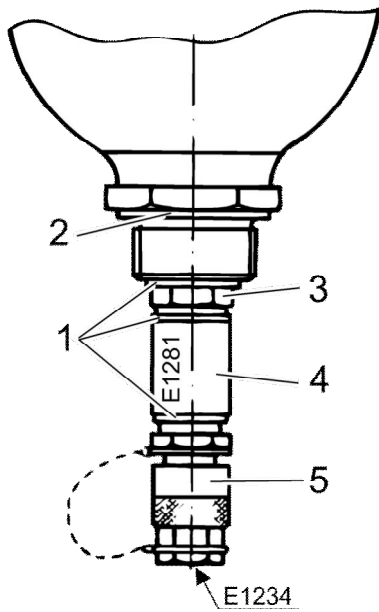

Figure 2

E 1281

1. Sealing washer
2. Accumulator with, M16 x 1.5 internal threads
3. Nipple, part No. 957030
4. Socket, standard 1/4" BSP
5. Measuring nipple, part No. 930032N

Document Title: Recommended lubricants	Function Group: 160	Information Type: Service Information	Date: 4/19/2026
Profile:			

Recommended lubricants

Oil

	Oil grade	Recommended viscosity at ambient temperatures																																																																																		
		°C	-30	-20	-10	0	+10	+20	+30	+40	+50																																																																									
		°F	-22	-4	+14	+32	+50	+68	+86	+104	+122																																																																									
Engine For severe conditions ACEA E3-96 is recommended to give optimum service life	Engine oil Volvo VDS API CE ACEA E1-96 (CCMC D4) and ACEA E3-96 (CCMC D5)	<table border="0"> <tr><td colspan="3">SAE 5W/30</td><td colspan="3"></td><td colspan="3"></td></tr> <tr><td colspan="4">SAE 10W/30</td><td colspan="2"></td><td colspan="4"></td></tr> <tr><td colspan="5">SAE 15W/40</td><td colspan="4"></td></tr> <tr><td colspan="6">SAE 30</td><td colspan="3"></td></tr> <tr><td colspan="7">SAE 40</td><td colspan="2"></td></tr> </table>									SAE 5W/30									SAE 10W/30										SAE 15W/40									SAE 30									SAE 40																																				
SAE 5W/30																																																																																				
SAE 10W/30																																																																																				
SAE 15W/40																																																																																				
SAE 30																																																																																				
SAE 40																																																																																				
Axles Hub gears	Volvo WB 101 For trade names and quality requirements of the oil, see "Specifications axles in the Operator's Manual.	<table border="0"> <tr><td colspan="10"> </td></tr> </table>																																																																																		
Transmission Dropbox	Transmission fluid which meets Allison C4 norm (DDAD C4) or Engine oil which meets Allison C4 norm (DDAD C4) or meets MIL 2104E.	<table border="0"> <tr><td colspan="3">SAE 5W/30</td><td colspan="3"></td><td colspan="3"></td></tr> <tr><td colspan="4">SAE 10W</td><td colspan="2"></td><td colspan="4"></td></tr> <tr><td colspan="5">SAE 10W/30</td><td colspan="4"></td></tr> <tr><td colspan="6">SAE 15W/40</td><td colspan="3"></td></tr> <tr><td colspan="7">SAE 30</td><td colspan="2"></td></tr> </table>									SAE 5W/30									SAE 10W										SAE 10W/30									SAE 15W/40									SAE 30																																				
SAE 5W/30																																																																																				
SAE 10W																																																																																				
SAE 10W/30																																																																																				
SAE 15W/40																																																																																				
SAE 30																																																																																				
Hydraulic system Steering system Break system Working hydraulics	Hydraulic oil Viscosity acc. to ISO Quality acc to ISO HV OR Engine oil min. requirement API SE/CD Note! As an alternative BP Biohyd SES 46 and Panolin HLP synth 46 can also be used.	<table border="0"> <tr><td colspan="3">ISO VG 46</td><td colspan="3"></td><td colspan="3"></td></tr> <tr><td colspan="4">ISO VG 68</td><td colspan="2"></td><td colspan="4"></td></tr> <tr><td colspan="5">ISO VG 100</td><td colspan="4"></td></tr> <tr><td colspan="3">SAE 5W/30</td><td colspan="3"></td><td colspan="3"></td></tr> <tr><td colspan="4">SAE 10W/30</td><td colspan="2"></td><td colspan="4"></td></tr> <tr><td colspan="5">SAE 15W/40</td><td colspan="4"></td></tr> <tr><td colspan="6">SAE 30</td><td colspan="3"></td></tr> <tr><td colspan="7">SAE 40</td><td colspan="2"></td></tr> </table>									ISO VG 46									ISO VG 68										ISO VG 100									SAE 5W/30									SAE 10W/30										SAE 15W/40									SAE 30									SAE 40								
ISO VG 46																																																																																				
ISO VG 68																																																																																				
ISO VG 100																																																																																				
SAE 5W/30																																																																																				
SAE 10W/30																																																																																				
SAE 15W/40																																																																																				
SAE 30																																																																																				
SAE 40																																																																																				
		°C	-30	-20	-10	0	+10	+20	+30	+40	+50																																																																									
		°F	-22	-4	+14	+32	+50	+68	+86	+104	+122																																																																									

Grease

Grease on lithium basis with EP additives and consistency NLGI No. 2.

NOTE!

If the machine is provided with automatic greasing, other recommended lubricants apply.

Cooling system

Volvo original coolant (anti-freeze)

Volvo original corrosion additives

USA: Coolant norm ASTM D4985

Fuel system

Quality requirements:

The fuel should at least meet the legal requirements, and national and international standards for marketed fuels, e.g. EN590 (with nationally adapted temperature requirements), ASTM D 975 No 1D and 2D, JIS KK 2204.

Sulphur content:

According to legal requirements (the sulphur content must not exceed 0.5 percent by weight).

Document Title: Manual release of parking brake	Function Group: 176	Information Type: Service Information	Date: 4/19/2026
Profile:			

Manual release of parking brake

Applies to L90C with electrically operated parking brake and L120C.
Block the wheels to prevent the machine from rolling.

If the parking brake cannot be released with the parking brake control, it is possible to release it manually as follows:

L90C

Release the parking brake by slackening lock nut A and then turning adjusting screw B counter-clockwise until the parking brake has been released, see [Invalid linktarget]

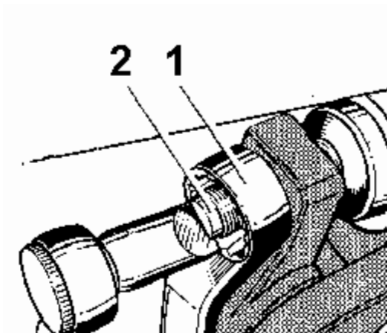

Figure 1

Releasing parking brake, L90C

1. Lock nut
2. Adjusting screw

It is now possible to move the machine **but the parking brake is not working**. The towed machine can now only be braked via the towbar from the towing vehicle.

When restoring the parking brake, it should be adjusted so that there is a clearance of approx. 0.25 mm (0.010 in) between the brake disc and the brake pads when the brake is released. The clearance between the brake disc and the brake pad can only be adjusted when the engine is running and the parking brake has been released with hydraulic pressure.

If the machine is left after towing/recovering without the parking brake having been restored, this fact must be indicated by attaching a notice to the steering wheel with information that the parking brake has been released manually and that it is not working.

Document Title: Removing propeller shafts	Function Group: 176	Information Type: Service Information	Date: 4/19/2026
Profile:			

Removing propeller shafts



WARNING

When the propeller shafts have been removed, the parking brake does not work!

1. Place the machine in service position.
2. Block the wheels to prevent the machine from rolling.
3. Remove the propeller shafts.

If the machine is left with the propeller shafts removed, this fact must be indicated by attaching a notice to the steering wheel stating that the propeller shafts have been removed.

Document Title: Towing	Function Group: 176	Information Type: Service Information	Date: 4/19/2026
Profile:			

Towing

WARNING

Before any further action is taken when preparing for towing or recovering, the parking brake must be applied and the wheels blocked to prevent the machine from rolling. The greatest care must be taken during work with towing/recovering to avoid injuries or, in the worst case, fatality.

Measures for towing/recovering.

For towing/recovering the engine should, if possible, be started, in order for the brake and the steering functions to operate satisfactorily.

WARNING

If the engine cannot be started.

As the function of the brakes and the steering will be limited, when the engine is not running, the machine may only be towed in an emergency and only the shortest possible distance under the supervision of trained personnel. If possible, transport the machine on a trailer. To release the parking brake, see manual release of parking brake for the respective machine types.

Recovering

Use a towbar for towing the machine to a suitable place or trafficable road. The towbar should be connected to the towing device according to [Invalid linktarget].

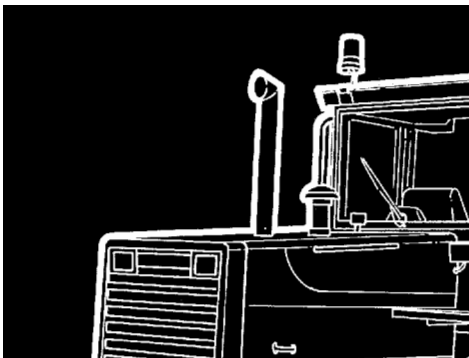

Figure 1

Towing device

NOTE!

The lifting eyes must not be used for recovering.

Towing

If the machine, after recovery, must be towed to a workshop, use a towbar connected to the towing device as above, or a wire rope attached to the eyes inside the front axle attachment to the frame.

NOTE!

If the brakes do not work (the engine cannot be started) a towbar must always be used.

The towing vehicle must be at least as heavy as the towed machine and have sufficient engine power and braking capacity to pull and brake both machines on any inclines which will be encountered.

Always tow the shortest possible distance, otherwise the transmission may be damaged.

At a towing distance exceeding 10 km (6 miles), or at a speed above 10 km/h (6 mph), both the front and rear propeller

shafts must be removed, see "Removing propeller shafts". Or alternatively the machine should be transported on a trailer.

After towing/recovering

The following safety measures should be taken before the towbar or wire rope is disconnected after towing/recovering:

1. If possible place the machine on level ground.
2. Apply the parking brake.
3. Block the wheels to prevent the machine from rolling.

Document Title: Transporting wheel loader on another vehicle	Function Group: 176	Information Type: Service Information	Date: 4/19/2026
Profile:			

Transporting wheel loader on another vehicle

In cases where the wheel loader is transported on another vehicle or by railroad, it is important that the opening at the end of the exhaust pipe is covered with a cap or some other protection. This is particularly important if the opening at the end of the exhaust pipe is pointing forward in the travelling direction, see [Invalid linktarget] . This is to avoid damage to the turbocharger bearings, which may occur, if the turbocharger rotates without lubrication.

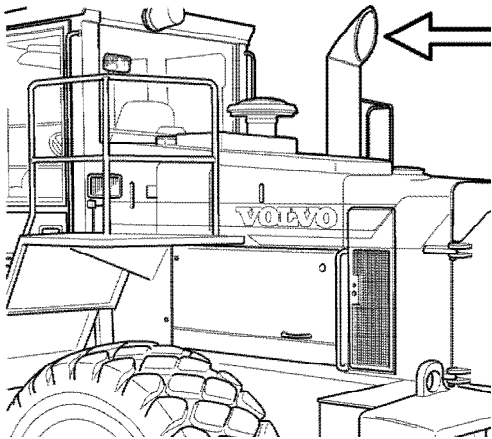

Figure 1

Document Title: Cleanliness, brake and hydraulic systems	Function Group: 179	Information Type: Service Information	Date: 4/19/2026
Profile:			

Cleanliness, brake and hydraulic systems

In all work on these systems the greatest possible cleanliness must be exercised. Wipe off all pipe and hose connections before disconnecting them and remove flakes of paint etc. Plug all pipes, hoses, cylinders etc. immediately after they have been disconnected. Never install an hydraulic hose which has not been sealed with plugs until it has been thoroughly cleaned.

Document Title: Electric welding	Function Group: 179	Information Type: Service Information	Date: 4/19/2026
Profile:			

Electric welding

Before carrying out electric welding on the machine or attachments connected to the machine, the battery disconnect switch must be turned off or the battery earth lead disconnected.

Connect the welding unit as close as possible to the point of welding.

Document Title: Repairing hydraulic system	Function Group: 179	Information Type: Service Information	Date: 4/19/2026
Profile:			

Repairing hydraulic system

When replacing a pump or after other repair work to the hydraulic system, where air may have entered the system, the points below should be followed:

1. Start the engine and run it at low idling for approx. 10 minutes without actuating any hydraulic functions.
2. Actuate all hydraulic functions a few times with the engine running at low idling.
NOTE!
The hydraulic cylinders must not be operated against their end-of-stroke positions.
3. Operate all hydraulic functions (the hydraulic cylinders against their end-of-stroke positions) causing overflow a few times at a raised engine speed, approx. 20 - 25 r/s (1200 - 1500 rpm).

Document Title: Description	Function Group: 200	Information Type: Service Information	Date: 4/19/2026
Profile:			

Description

L90C is equipped with an engine with the designation TD63KBE.

L120C is equipped with an engine with the designation TD73KDE.

Both engines are six-cylinder, four-stroke, direct injected, turbocharged diesel engines and both are of the low-emission version.

Document Title: Engine, installing	Function Group: 210	Information Type: Service Information	Date: 4/19/2026
Profile:			

Engine, installing

Op nbr 21072

[Lifting sling, 3 m \(10 ft\)](#)

[Shackle 3/8"](#)

[Ratchet block, 750 kg \(1653 lb\)](#)

1. Connect a lifting device to the engine according to [Invalid linktarget].
Weight: **approx. 750 kg (1653 lb)**

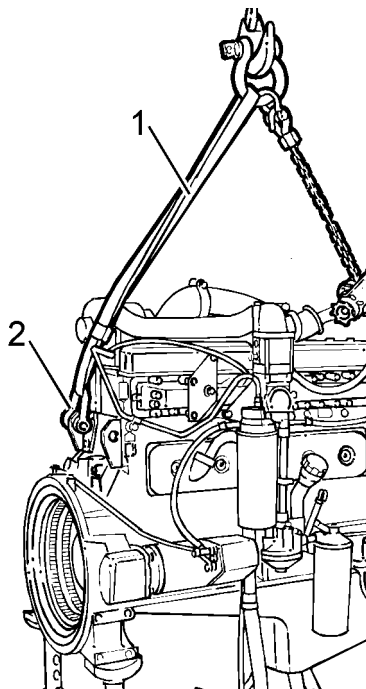

Figure 1

Connecting lifting device

1. Lifting sling, 3 m (10 ft)
 2. Shackle 3/8"
 3. Ratchet block 750 kg (1653 lb)
2. Lift the engine into the machine.
NOTE!
Make sure that the hoses for the air conditioning (if installed) are not damaged.
 3. Align the engine against the transmission and install the bolts.
Tightening torque: **85 ±8 N m (63 ±6 lbf ft)**
Remove any supports from under the transmission.
 4. Install the bolts between the engine mountings and the rubber elements.
Tightening torque: **220 ±22 N m (162 ±16 lbf ft)**

5. Bolt the transmission oil cooler onto the bracket on the engine.
6. Install the hub for the fan belt pulley, bracket and tensioning pulley.
7. Bolt on the compressor (if installed) for the air conditioning and install its drive belt and the fan belts.
8. Install the stays between the engine and the air-guide ring.
9. Install the fan.
10. Install the coolant pipe between the coolant pump and the transmission oil cooler, replace the O-ring. Connect the expansion tank and the climate control system hose to the pipe and the coolant filter (if installed) hose.
11. Bolt the fuel system water trap onto the bracket on the frame. Connect the fuel lines to the feed pump and the injection pump.
12. Connect the cable harness to B+ on the alternator, connector BB to the stop solenoid and SE1 to the temperature sensor.
Clamp the cable harness with the screw clips.
13. Connect the accelerator control to the injection pump.
14. Bolt the preheating element relay bracket and bracket for air conditioning receiver drier (if installed) onto the bracket on the engine inlet pipe. Connect the lead to the preheating element.
15. Connect the ground lead to the starter motor (black terminal).
Connect the red leads of the cable harnesses to the starter motor (red terminal).
16. Connect the leads to the oil pressure sensor and to the air cleaner indicator and clamp the cable harness with the screw clips.
17. Install the upper radiator hose.
18. Install the breather filter and bolt on the pump for the secondary steering (if installed).
19. Lift the hood assembly into position, see [Invalid linktarget].
Weight: **approx. 100 kg (220 lb)**

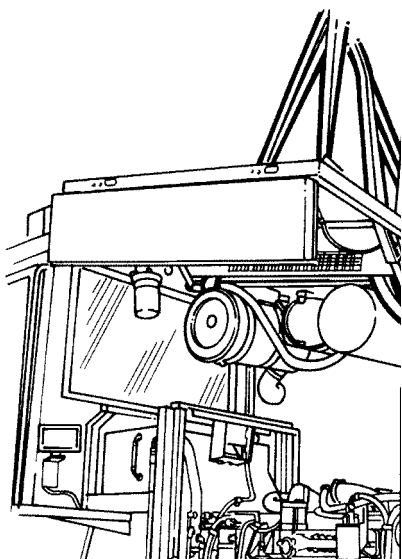

Figure 2
Installing hood assembly