



Document Title: <b>Volvo standard tightening torques</b>	Function Group: <b>030</b>	Information Type: <b>Service Information</b>	Date: <b>4/18/2026</b>
Profile: <b>L70G Volvo</b>			

## Volvo standard tightening torques

Showing Selected Profile

Valid for serial numbers			
Model	Production site	Serial number start	Serial number stop
L70G Volvo			

The tightening torques in the following tables apply to bolts and nuts with tensile strength. The tables should be used as a general instruction for tightening bolts and nuts without specified values. The charts contains values for course thread bolts and nuts.

Torque values should be increased with ≈10%, for flange bolts.

All standard torques for bolts are without surface treatment.

The standard torque for bolts lubricated with oil should be reduced with 20% of the given value.

### Standard tightening torque charts

Bolt size Metric Coarse Threads	Tensile strength 8.8		Tensile strength 10.9	
	(Nm)	(lbf ft)	(Nm)	(lbf ft)
M5	6	4	8	6
M6	10	7	14	11
M8	25	18	35	26
M10	50	37	70	52
M12	87	64	122	90
M14	139	103	195	144
M16	213	157	299	220
M18	293	216	413	305
M20	416	307	585	432
M24	719	530	1010	745
M27	1060	782	1490	1100
M30	1140	840	2025	1493
M36	2500	1844	3600	2653

Bolt size Inch SAE Coarse Threads	Tensile strength 5		Tensile strength 8	
	(lbf ft)	(Nm)	(lbf ft)	(Nm)
1/4	10	13,6	14	19
5/16	21	28,5	29	39,3
3/8	37	50,2	52	70
7/16	59	80	84	114
1/2	90	122	128	174
9/16	130	176	184	250
5/8	200	271	284	390
3/4	270	365	384	520
7/8	350	474	500	670
1	450	610	640	870
1 1/8	600	815	850	1150
1 1/4	750	1020	1070	1450
1 3/8	900	1225	1280	1750
1 1/2	1100	1490	1560	2150
1 3/4	1350	1860	1950	2650
2	1650	2280	2380	3300
2 1/4	2100	2870	3000	4100
2 3/4	2550	3460	3620	5000
3	3000	4050	4250	5800
3 1/2	3500	4740	5000	6800
4	4000	5430	5750	7800
4 1/2	4500	6120	6500	8800
5	5000	6810	7250	9800
5 1/2	5500	7500	7900	10800
6	6000	8190	8600	11800
6 1/2	6500	8880	9300	12800
7	7000	9570	10000	13800
7 1/2	7500	10260	10750	14800
8	8000	10950	11500	15800
8 1/2	8500	11640	12250	16800
9	9000	12330	13000	17800
9 1/2	9500	13020	13750	18800
10	10000	13710	14500	19800
10 1/2	10500	14400	15250	20800
11	11000	15090	16000	21800
11 1/2	11500	15780	16750	22800
12	12000	16470	17500	23800
12 1/2	12500	17160	18250	24800
13	13000	17850	19000	25800
13 1/2	13500	18540	19750	26800
14	14000	19230	20500	27800
14 1/2	14500	20000	21250	28800
15	15000	20790	22000	29800
15 1/2	15500	21580	22750	30800
16	16000	22370	23500	31800
16 1/2	16500	23160	24250	32800
17	17000	23950	25000	33800
17 1/2	17500	24740	25750	34800
18	18000	25530	26500	35800
18 1/2	18500	26320	27250	36800
19	19000	27110	28000	37800
19 1/2	19500	27900	28750	38800
20	20000	28690	29500	39800
20 1/2	20500	29480	30250	40800
21	21000	30270	31000	41800
21 1/2	21500	31060	31750	42800
22	22000	31850	32500	43800
22 1/2	22500	32640	33250	44800
23	23000	33430	34000	45800
23 1/2	23500	34220	34750	46800
24	24000	35010	35500	47800
24 1/2	24500	35800	36250	48800
25	25000	36590	37000	49800
25 1/2	25500	37380	37750	50800
26	26000	38170	38500	51800
26 1/2	26500	38960	39250	52800
27	27000	39750	40000	53800
27 1/2	27500	40540	40750	54800
28	28000	41330	41500	55800
28 1/2	28500	42120	42250	56800
29	29000	42910	43000	57800
29 1/2	29500	43700	43750	58800
30	30000	44490	44500	59800
30 1/2	30500	45280	45250	60800
31	31000	46070	46000	61800
31 1/2	31500	46860	46750	62800
32	32000	47650	47500	63800
32 1/2	32500	48440	48250	64800
33	33000	49230	49000	65800
33 1/2	33500	50020	49750	66800
34	34000	50810	50500	67800
34 1/2	34500	51600	51250	68800
35	35000	52390	52000	69800
35 1/2	35500	53180	52750	70800
36	36000	53970	53500	71800
36 1/2	36500	54760	54250	72800
37	37000	55550	55000	73800
37 1/2	37500	56340	55750	74800
38	38000	57130	56500	75800
38 1/2	38500	57920	57250	76800
39	39000	58710	58000	77800
39 1/2	39500	59500	58750	78800
40	40000	60290	59500	79800
40 1/2	40500	61080	60250	80800
41	41000	61870	61000	81800
41 1/2	41500	62660	61750	82800
42	42000	63450	62500	83800
42 1/2	42500	64240	63250	84800
43	43000	65030	64000	85800
43 1/2	43500	65820	64750	86800
44	44000	66610	65500	87800
44 1/2	44500	67400	66250	88800
45	45000	68190	67000	89800
45 1/2	45500	68980	67750	90800
46	46000	69770	68500	91800
46 1/2	46500	70560	69250	92800
47	47000	71350	70000	93800
47 1/2	47500	72140	70750	94800
48	48000	72930	71500	95800
48 1/2	48500	73720	72250	96800
49	49000	74510	73000	97800
49 1/2	49500	75300	73750	98800
50	50000	76090	74500	99800
50 1/2	50500	76880	75250	100800
51	51000	77670	76000	101800
51 1/2	51500	78460	76750	102800
52	52000	79250	77500	103800
52 1/2	52500	80040	78250	104800
53	53000	80830	79000	105800
53 1/2	53500	81620	79750	106800
54	54000	82410	80500	107800
54 1/2	54500	83200	81250	108800
55	55000	83990	82000	109800
55 1/2	55500	84780	82750	110800
56	56000	85570	83500	111800
56 1/2	56500	86360	84250	112800
57	57000	87150	85000	113800
57 1/2	57500	87940	85750	114800
58	58000	88730	86500	115800
58 1/2	58500	89520	87250	116800
59	59000	90310	88000	117800
59 1/2	59500	91100	88750	118800
60	60000	91890	89500	119800
60 1/2	60500	92680	90250	120800
61	61000	93470	91000	121800
61 1/2	61500	94260	91750	122800
62	62000	95050	92500	123800
62 1/2	62500	95840	93250	124800
63	63000	96630	94000	125800
63 1/2	63500	97420	94750	126800
64	64000	98210	95500	127800
64 1/2	64500	99000	96250	128800
65	65000	99790	97000	129800
65 1/2	65500	100580	97750	130800
66	66000	101370	98500	131800
66 1/2	66500	102160	99250	132800
67	67000	102950	100000	133800
67 1/2	67500	103740	100750	134800
68	68000	104530	101500	135800
68 1/2	68500	105320	102250	136800
69	69000	106110	103000	137800
69 1/2	69500	106900	103750	138800
70	70000	107690	104500	139800
70 1/2	70500	108480	105250	140800
71	71000	109270	106000	141800
71 1/2	71500	110060	106750	142800
72	72000	110850	107500	143800
72 1/2	72500	111640	108250	144800
73	73000	112430	109000	145800
73 1/2	73500	113220	109750	146800
74	74000	114010	110500	147800
74 1/2	74500	114800	111250	148800
75	75000	115590	112000	149800
75 1/2	75500	116380	112750	150800
76	76000	117170	113500	151800
76 1/2	76500	117960	114250	152800
77	77000	118750	115000	153800
77 1/2	77500	119540	115750	154800
78	78000	120330	116500	155800
78 1/2	78500	121120	117250	156800
79	79000	121910	118000	157800
79 1/2	79500	122700	118750	158800
80	80000	123490	119500	159800
80 1/2	80500	124280	120250	160800
81	81000	125070	121000	161800
81 1/2	81500	125860	121750	162800
82	82000	126650	122500	163800
82 1/2	82500	127440	123250	164800
83	83000	128230	124000	165800
83 1/2	83500	129020	124750	166800
84	84000	129810	125500	167800
84 1/2	84500	130600	126250	168800
85	85000	131390	127000	169800
85 1/2	85500	132180	127750	170800
86	86000	132970	128500	171800
86 1/2	86500	133760	129250	172800
87	87000	134550	130000	173800
87 1/2	87500	135340	130750	174800
88	88000	136130	131500	175800
88 1/2	88500	136920	132250	176800
89	89000	137710	133000	177800
89 1/2	89500	138500	133750	178800
90	90000	139290	134500	179800
90 1/2	90500	140080	135250	180800
91	91000	140870	136000	181800
91 1/2	91500	141660	136750	182800
92	92000	142450	137500	183800
92				

Product: L70G Volvo Wheel Loaders Service Manual

Full Download: <https://www.arepairmanual.com/downloads/l70g-volvo-wheel-loaders-service-manual/>

3/4	320	434	451	612
7/8	515	700	728	988
1	775	1052	1091	1480
1 1/8	953	1290	1545	2100
1 1/4	1344	1823	2180	2960
1 3/8	1600	2170	2650	3600
1 1/2	2000	2714	3200	4340

Sample manual. Download All 2240 pages at:

<https://www.arepairmanual.com/downloads/l70g-volvo-wheel-loaders-service-manual/>

Document Title: <b>Engine, software specifications</b>	Function Group: <b>030</b>	Information Type: <b>Service Information</b>	Date: <b>4/18/2026</b>
Profile: <b>L70G Volvo</b>			

## Engine, software specifications

Showing Selected Profile

Valid for serial numbers			
Model	Production site	Serial number start	Serial number stop
L70G Volvo			

### Engine protection

Function	Action	Limit/cause
High coolant temperature	Yellow lamp on Red lamp on Both lamps off [T1] ⓘ Engine shut down	104°C (219°F) 107°C (225°F) 100°C (212°F) 116°C (241°F)
High inlet manifold air pressure	Red lamp on Red lamp off	0.35 MPa (51 PSI) 0.25 MPa (36 PSI)
High inlet manifold air temperature	Yellow lamp on Red lamp on	120°C (240°F) 140°C (284°F)
High oil temperature	Yellow lamp on Red lamp on Both lamps off [T2] ⓘ	125°C (257°F) 128°C (262°F) 123°C (253°F)
Low oil pressure	Red lamp and forced idle Engine shut down	0.5– 2 MPa (73–290 PSI)[T3] ⓘ
Low coolant level	Yellow lamp	[T4] ⓘ
High temperature of cooled EGR exhausts after the EGR cooler	Yellow lamp on Red lamp on Derate	200°C (392°F) 240°C (464°F) [T5] ⓘ
High E-ECU temperature	Red lamp on and derate	95°C (203°F)
High soot load	Yellow lamp Buzzer	100%
	Yellow lamp Buzzer Start derate	130%
	Red lamp Buzzer continuous Max derate [T6] ⓘ	140%
	Red lamp Buzzer continuous Max derate [T7] ⓘ	170%
	Red lamp Buzzer continuous Max derate [T8] ⓘ	200%
Air pump failure	Red lamp Derate [T9] ⓘ	Air pump failure

**[T1]** If the temperature has triggered yellow or red lamp, the temperature has to decrease to specified value for turning the lamps off.

**[T2]** If the temperature has triggered yellow or red lamp, the temperature has to decrease to specified value for turning the lamps off.

**[T3]** The red lamp is lit and force idle is performed when the oil pressure is lower than the specified value for 80% of the time during a 4 sec period. When vehicle speed is ~0km/h the engine will be forced shut off.

**[T4]** Yellow lamp is lit when the coolant level in the expansion tank has been below low level for 90% of the time during a 15 sec period.

**[T5]** If the temperature exceeds specified value for yellow lamp for more than 20% within a 30 sec period, the derate starts. At specified value for red lamp the derate will be 100%.

**[T6]** Stand still regeneration required

**[T7]** Service regeneration required

**[T8]** DPF replacement required

**[T9]** Startup delay 30 seconds.

Document Title: <b>Thermostat, specifications</b>	Function Group: <b>030</b>	Information Type: <b>Service Information</b>	Date: <b>4/18/2026</b>
Profile: <b>L70G Volvo</b>			

## Thermostat, specifications

Showing Selected Profile

<b>Valid for serial numbers</b>			
<b>Model</b>	<b>Production site</b>	<b>Serial number start</b>	<b>Serial number stop</b>
L70G Volvo			

<b>Cooling system</b>	
Thermostat begins to open at	83 °C (181 °F)
Thermostat fully open at	95 °C (203 °F)

Document Title: <b>EGR system, tightening torques</b>	Function Group: <b>030</b>	Information Type: <b>Service Information</b>	Date: <b>4/18/2026</b>
Profile: <b>L70G Volvo</b>			

## EGR system, tightening torques

Showing Selected Profile

Valid for serial numbers			
Model	Production site	Serial number start	Serial number stop
L70G Volvo			

Part	Torque
Pipe brackets, fastening	13 Nm (10 lbf ft)
Bracket on crankcase (exhaust gas return)	30 Nm (22 lbf ft)
Hose bracket, exhaust pipe on Venturi tube (exhaust gas return)	4 Nm (3 lbf ft)
Pin screws on exhaust pipe	15 Nm (11 lbf ft)
<b>Cooler</b>	
Connection piece on cooler (exhaust gas return)	13 Nm (10 lbf ft)
Cooler on bracket (exhaust gas return)	30 Nm (22 lbf ft)
Flutter valve housing on cooler (exhaust gas return)	30 Nm (22 lbf ft)
Connection piece on cooler (exhaust gas return)	13 Nm (10 lbf ft)
Cooler on exhaust pipe	25 Nm (18 lbf ft)
Clip on bracket (exhaust gas return)	20 Nm (15 lbf ft)
Clip on clip (exhaust gas return)	20 Nm (15 lbf ft)
<b>Actuator</b>	
Cooler on bracket, actuator	30 Nm (22 lbf ft)
Actuator on bracket	13 Nm (10 lbf ft)
Positioning level	15 Nm (11 lbf ft)
Heat shield on bracket	13 Nm (10 lbf ft)
Screw in nozzle	49 Nm (36 lbf ft)
Pipe union pipe $\varnothing$ 10 mm, ring piece	39 Nm (29 lbf ft)
Adjusting rod on position lever	20 Nm (15 lbf ft)
<b>Shut off valve</b>	
Shut off valve on cooler	5 Nm (3.7 lbf ft)

For the tightening procedure according to torque using a torque wrench, a maximum variation of the tightening torque of  $\pm 10\%$  is permissible.

Document Title: <b>Conversion tables</b>	Function Group: <b>030</b>	Information Type: <b>Service Information</b>	Date: <b>4/18/2026</b>
Profile: <b>L70G Volvo</b>			

## Conversion tables

Showing Selected Profile

Valid for serial numbers			
Model	Production site	Serial number start	Serial number stop
L70G Volvo			

### Length

Unit	cm	m	km	in	ft	yd	mile
cm	1	0.01	0.00001	0.3937	0.03281	0.01094	0.000006
m	100	1	0.001	39.37	3.2808	1.0936	0.00062
km	100000	1000	1	39370.7	3280.8	1093.6	0.62137
in	2.54	0.0254	0.000025	1	0.08333	0.02777	0.000015
ft	30.48	0.3048	0.000304	12	1	0.3333	0.000189
yd	91.44	0.9144	0.000914	36	3	1	0.000568
mile	160930	1609.3	1.6093	63360	5280	1760	1

1 mm = 0.1 cm - 1 mm = 0.001 m

### Area

Unit	cm <sup>2</sup>	m <sup>2</sup>	km <sup>2</sup>	a	ft <sup>2</sup>	yd <sup>2</sup>	in <sup>2</sup>
cm <sup>2</sup>	1	0.0001	-	0.000001	0.001076	0.000012	0.155000
m <sup>2</sup>	10000	1	0.000001	0.01	10.764	1.1958	1550.000
km <sup>2</sup>	-	1000000	1	10000	1076400	1195800	-
a	0.01	100	0.0001	1	1076.4	119.58	-
ft <sup>2</sup>	-	0.092903	-	0.000929	1	0.1111	144.000
yd <sup>2</sup>	-	0.83613	-	0.008361	9	1	1296.00
in <sup>2</sup>	6.4516	0.000645	-	-	0.006943	0.000771	1

1 ha = 100 a - 1 mile<sup>2</sup> = 259 ha = 2.59 km<sup>2</sup>

### Volume

Unit	cm <sup>3</sup> = cc	m <sup>3</sup>	l	in <sup>3</sup>	ft <sup>3</sup>	yd <sup>3</sup>
cm <sup>3</sup> = ml	1	0.000001	0.001	0.061024	0.000035	0.000001
m <sup>3</sup>	1000000	1	1000	61024	35.315	1.30796
dm <sup>3</sup> (l)	1000	0.001	1	61.024	0.035315	0.001308
in <sup>3</sup>	16.387	0.000016	0.01638	1	0.000578	0.000021
ft <sup>3</sup>	28316.8	0.028317	28.317	1728	1	0.03704
yd <sup>3</sup>	764529.8	0.76453	764.53	46656	27	1

1 gal (US) = 3785.41 cm<sup>3</sup> = 231 in<sup>3</sup> = 0.83267 gal (UK)

### Weight

Unit	g	kg	t	oz	lb
g	1	0.001	0.000001	0.03527	0.0022
kg	1000	1	0.001	35.273	2.20459
t	1000000	1000	1	35273	2204.59
oz	28.3495	0.02835	0.000028	1	0.0625
lb	453.592	0.45359	0.000454	16	1

1 ton (metric) = 1.1023 ton (US) = 0.9842 ton (UK)

### Pressure

Unit	kp/cm <sup>2</sup>	bar	Pa=N/m <sup>2</sup>	kPa	lbf/in <sup>2</sup>	lbf/ft <sup>2</sup>
kp/cm <sup>2</sup>	1	0.98067	98066.5	98.0665	14.2233	2048.16
bar	1.01972	1	100000	100	14.5037	2088.6
Pa=N/m <sup>2</sup>	0.00001	0.001	1	0.001	0.00015	0.02086
kPa	0.01020	0.01	1000	1	0.14504	20.886
lbf/in <sup>2</sup>	0.07032	0.0689	6894.76	6.89476	1	144
lbf/ft <sup>2</sup>	0.00047	0.00047	47.88028	0.04788	0.00694	1

kg/cm<sup>2</sup> = 735.56 Dry (mmHg) = 0.96784 atm

### Unit explanations

Unit	abbreviation
Newton meter	Nm
Kilopoundmeter	kpm
Kilopascal	kPa
Megapascal	MPa
Kilowatt	kW
kilojoule	kJ
British thermal unit	Btu
Calorie	cal

### Approx. conversion

SI unit	Conversion factor	Non SI	Conversion factor	SI
<b>Torque</b>				
Nm	x10.2	=kg/cm	x0.8664	=lb in
Nm	x0.74	=lbf-ft	x1.36	=Nm
Nm	x0.102	=kg/m	x7.22	=lbft
<b>Pressure (Pa = N/m<sup>2</sup>)</b>				
kPa	x4.0	=in.H <sub>2</sub> O	x0.249	=kPa
kPa	x0.30	=in.Hg	x3.38	=kPa
kPa	x0.145	=psi	x6.89	=kPa
bar	x14.5	=psi	x0.069	=bar
kp/cm <sup>2</sup>	x14.22	=psi	x0.070	=kp/cm <sup>2</sup>
N/mm <sup>2</sup>	x145.04	=psi	x0.069	=bar
MPa	x145	=psi	x0.00689	=MPa
<b>Power (W = J/s)</b>				
kW	x1.36	=hp(cv)	x0.736	=kW

kW	x1.34	= bhp	x0.746	= kW
kW	x0.948	= Btu/s	x1.055	= kW
W	x0.74	= ft-lb/s	x1.36	= W
Energy (J = Nm)				
kJ	x0.948	= Btu	x1.055	= kJ
J	x0.239	= calorie	x4.19	= J
Speed and acceleration				
m/s <sup>2</sup>	x3.28	= ft/s <sup>2</sup>	x0.305	= m/s <sup>2</sup>
m/s	x3.28	= ft/s	x0.305	= m/s
km/h	x0.62	= mph	x1.61	= km/h
Horsepower/torque				
Bhp x5252 rpm= TQ (lb-ft)			TQ x rpm 5252=bhp	
Temperature				
$^{\circ}\text{C} = (^{\circ}\text{F} - 32) / 1.8$			$^{\circ}\text{F} = (^{\circ}\text{C} \times 1.8) + 32$	
Flow factor				
l/min (dm <sup>3</sup> /min)	x0.264	= US gal/min	x3.785	= liter/min

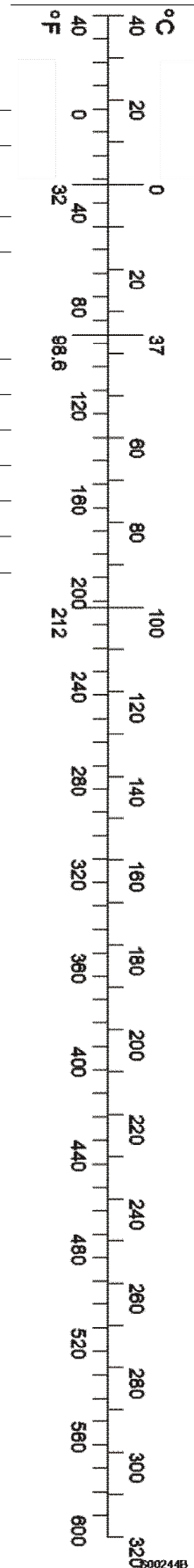

Document Title: <b>Fuel system, specifications</b>	Function Group: <b>030</b>	Information Type: <b>Service Information</b>	Date: <b>4/18/2026</b>
Profile: <b>L70G Volvo</b>			

## Fuel system, specifications

Showing Selected Profile

Valid for serial numbers			
Model	Production site	Serial number start	Serial number stop
L70G Volvo			

Fuel feed pump	
Type	Gear pump
Safety valve	1.5 MPa (217.6 psi)
Opening pressure	0.975 MPa (141.4 psi)
Fully opened	1.45 MPa (210.3 psi)
Feed pressure at:	
600 rpm	min. 0.56–0.64 MPa (81.2–92.8 psi)
1200 rpm	min. 0.56–0.65 MPa (81.2–94.3 psi)

Fuel Control Valve (FCV) — Overflow valve	
Opening pressure	0.46 MPa (66.7 psi)

Fuel rail	
Injection pressure at injectors	between 30–155 MPa (4351–22481 psi)
Maximum pressure	155 MPa (22481 psi)
Over-pressure (PRV opening pressure 1)	180–200 MPa (26107–29008 psi)
Injector fuel return flow, idling speed	Max 95 ml/min (3.21 US oz./min)
D4H	Max 115 ml/min (3.89 US oz./min)
D6H	

Pressure Release Valve (PRV)	
Opening pressure	180–200 MPa (26107–29008 psi)
Pressure when open	70–90 MPa (10153–13053 psi)
Life time limits:	50 openings 300 minutes in PRV open mode accumulated Lifetime limits are not monitored by main software, no error messages when limits are exceeded. PRV openings are logged in the EMS error memory

Document Title: <b>Lubrication specifications</b>	Function Group: <b>system, 030</b>	Information Type: <b>Service Information</b>	Date: <b>4/18/2026</b>
Profile: <b>L70G Volvo</b>			

### Lubrication system, specifications

Showing Selected Profile

Valid for serial numbers			
Model	Production site	Serial number start	Serial number stop
L70G Volvo			

#### Minimum oil pressure, recommendation

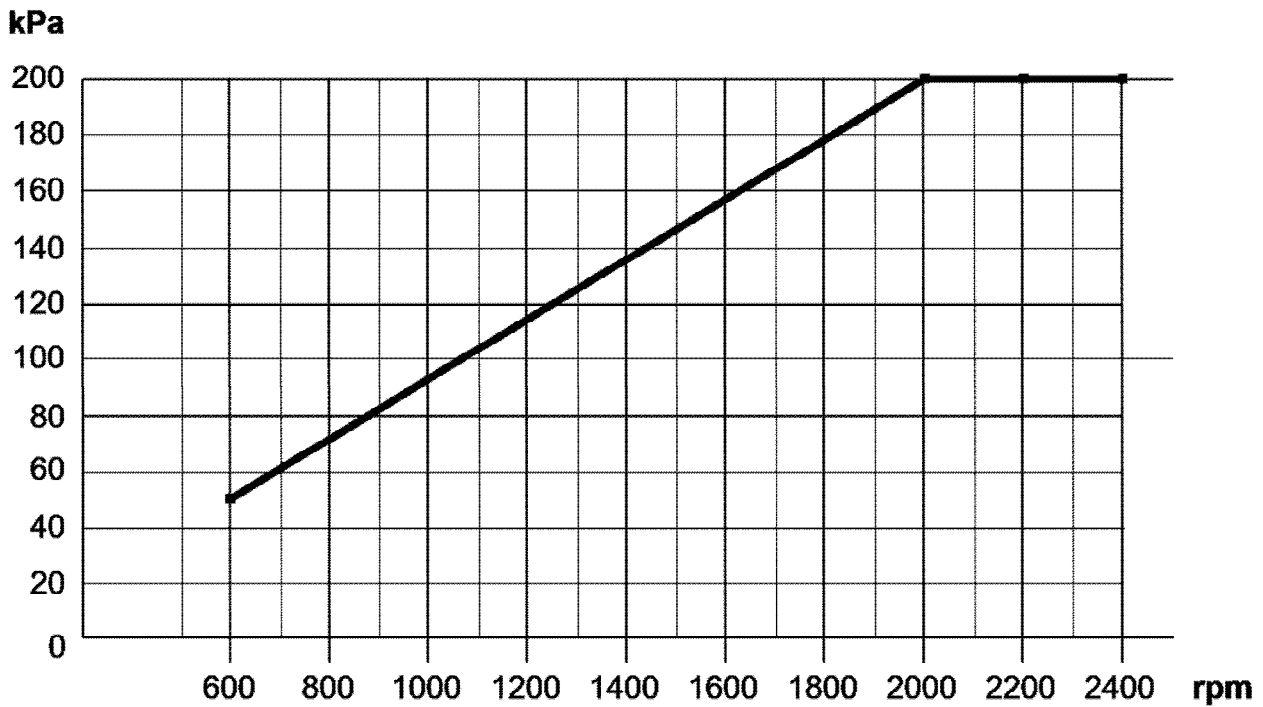

V1178956

**Figure 1**

Minimum oil pressure, guide

**NOTE!**

If the engine is operated continuously in the critical range, engine damage is expected in the long run.

#### Oil consumption

Lubricating oil, approx. maximum consumption	0.75 % of fuel consumption
--	----------------------------

Document Title: <b>Lubrication specifications</b>	Function Group: <b>system, 030</b>	Information Type: <b>Service Information</b>	Date: <b>4/18/2026</b>
Profile: <b>L70G Volvo</b>			

### Lubrication system, specifications

Showing Selected Profile

Valid for serial numbers			
Model	Production site	Serial number start	Serial number stop
L70G Volvo			

### Minimum oil pressure, recommendation

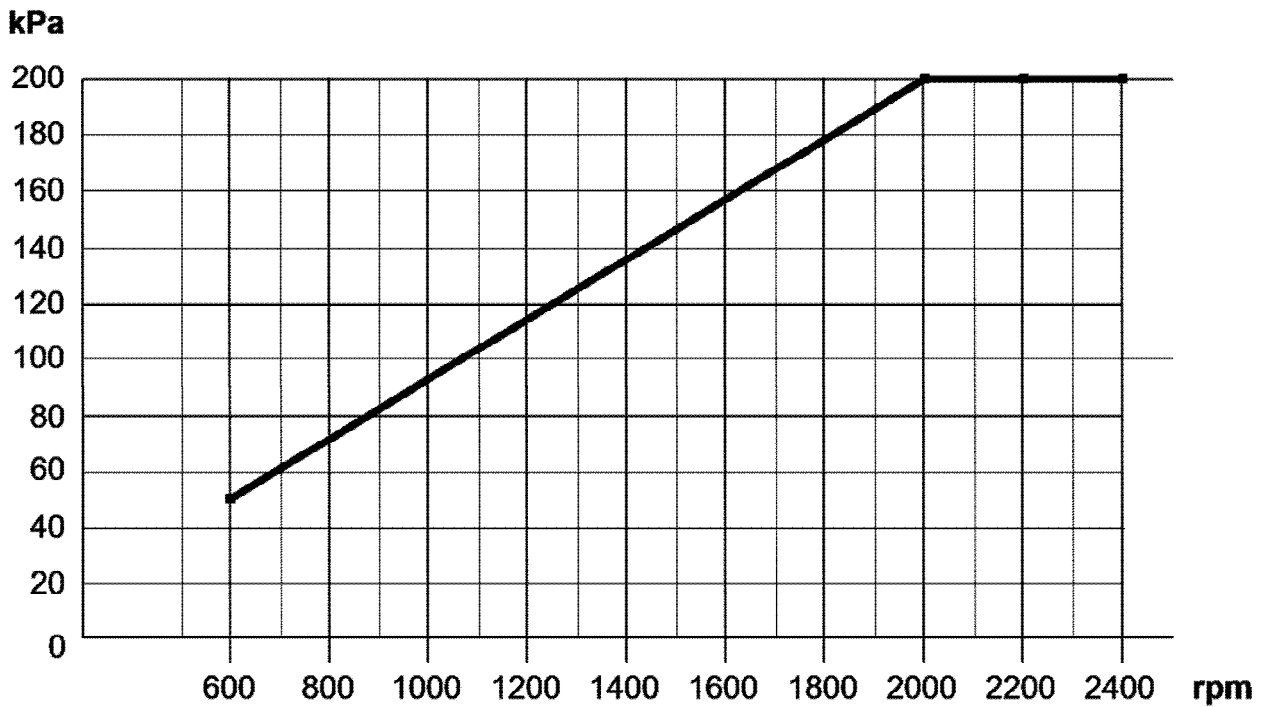

V1178956

**Figure 1**

Minimum oil pressure, guide

**NOTE!**

If the engine is operated continuously in the critical range, engine damage is expected in the long run.

### Oil consumption

Lubricating oil, approx. maximum consumption	0.75 % of fuel consumption
--	----------------------------

Document Title: <b>Engine, tighten torques</b>	Function Group: <b>030</b>	Information Type: <b>Service Information</b>	Date: <b>4/18/2026</b>
Profile: <b>L70G Volvo</b>			

## Engine, tightening torques

Showing Selected Profile

Valid for serial numbers			
Model	Production site	Serial number start	Serial number stop
L70G Volvo			

### NOTICE

Regarding bolted joints which are not listed here, see "Volvo standard tightening torques"

Part	Comment	Torque
<b>Engine mounting</b>		
Flywheel housing – hydraulic transmission		57 ±6 Nm (42 ±4 lbf ft)
Flywheel housing – crankcase, M12		99 ±10 Nm (73 ±7.3 lbf ft)
Flywheel housing – crankcase, M16		243 ±25 Nm (179 ±18 lbf ft)
Front engine mount, rubber pads – frame		92 ±9 Nm (68 ±7 lbf ft)
Front engine mount, rubber pads – engine mount		150 ±15 Nm (110 ±11 lbf ft)
Front engine mount, engine member – engine block		270 ±27 Nm (199 ±20 lbf ft)
<b>Torsional vibration damper</b>		
Belt pulley/torsional vibration damper	Step 1	40 Nm (30 lbf ft)
Belt pulley/torsional vibration damper	Step 2, angle tightening	60°
Belt pulley/torsional vibration damper	Step 3, angle tightening	60°
V-belt pulley		110 Nm (81 lbf ft)
<b>Cylinder head cover</b>		
Cylinder head cover on cylinder head	Tighten screws alternately	8.5 Nm (6 Lbf ft)
Cable duct on cylinder head cover		8.5 Nm (6 Lbf ft)
Cable connection on injector		1.5 Nm (1 Lbf ft)
<b>Flywheel</b>		
Flywheel on crankshaft	Step 1 Tighten screws alternately	30 ±3 Nm (22 ±2 lbf ft)
	Step 2, angle-tightening Tighten screws alternately	60°
	Step 3, angle-tightening Tighten screws alternately	60°
<b>Valve mechanism</b>		
Inlet valves, angle-tightening		To zero clearance, then 75° counter-clockwise
Exhaust valves, angle-tightening		To zero clearance, then 120° counter-clockwise
Lock nut, valves		20 ±2 Nm (14.8 ±1.5 lbf ft)
Valve cover		8,5 Nm (6.3 lbf ft)

Document Title: <b>Engine, specifications</b>	Function Group: <b>030</b>	Information Type: <b>Service Information</b>	Date: <b>4/18/2026</b>
Profile: <b>L70G Volvo</b>			

## Engine, specifications

Showing Selected Profile

Valid for serial numbers			
Model	Production site	Serial number start	Serial number stop
L70G Volvo			

### General

Number of cylinders	6
Cylinder bore	98 mm (3.86 in)
Stroke	126 mm (4.96 in)
Displacement	5.70 litres (1.51 US gal)
Injection order	1-5-3-6-2-4
Low idle	700 rpm
High idle (run out speed)	2375 rpm
Weight, engine	610 kg (1345 lbs)

### Stall speed torque converter<sup>(1)</sup>

<b>L60G</b> <sup>(2)</sup> HTE125 (22579)	1970–2060 rpm
<b>L70G</b> <sup>(2)</sup> HTE125 (22579)	2020–2150 rpm
<b>L90G</b> <sup>(2)</sup> HTE125 (22579)	2050–2170 rpm

(1) Shall be performed on gear 2, APS-mode service (manual), and without using the hydraulics.

(2) The transmission part number can be found in the machine card in PROSIS.

Document Title: <b>Operation numbers for additional work</b>	Function Group: <b>070</b>	Information Type: <b>Service Information</b>	Date: <b>4/18/2026</b>
Profile: <b>Wheel Loaders (WLO)</b>			

## Operation numbers for additional work

Showing Selected Profile

These operations can be used to identify work that is not included in the time guide or described in the methods in the Service Manual. When these operations are used, a description of the work that has been performed must be provided.

### Other work related to engine

Op. no. 070-210

This operation can be used when work has been done related to the engine and function group 2 when no applicable method description was available. When this operation is used, additional information is required:

- Description of work that has been done

### Other work related to electrical system

Op. no. 070-310

This operation can be used when work has been done related to the electrical system and function group 3 when no applicable method description was available. When this operation is used, additional information is required:

- Description of work that has been done

### Other work related to transmission, gearbox, travel motor, swing motor

Op. no. 070-410

This operation can be used when work has been done related to the transmission, gearbox, travel motor or swing motor and function group 4 when no applicable method description was available. When this operation is used, additional information is required:

- Description of work that has been done

### Other work related to drive axle

Op. no. 070-470

This operation can be used when work has been done related to the drive axle and function group 46 when no applicable method description was available. When this operation is used, additional information is required:

- Description of required work that have been done

### Other work related to brake system

Op. no. 070-510

This operation can be used when work has been done related to the brake system and function group 5 when no applicable

method description was available. When this operation is used, additional information is required:

- Description of work that has been done

**Other work related to steering system**

Op. no. 070-610

This operation can be used when work has been done related to the steering system and function group 6 when no applicable method description was available. When this operation is used, additional information is required:

- Description of work that has been done

**Other work related to frame link, axle suspension**

Op. no. 070-710

This operation can be used when work has been done related to the frame link, axle suspension and other parts related to function group 7 when no applicable method description was available. When this operation is used, additional information is required:

- Description of work that has been done

**Other work related to cab, air conditioning**

Op. no. 070-810

This operation can be used when work has been done related to the cab, air conditioning and other parts related to function group 8 when no applicable method description was available. When this operation is used, additional information is required:

- Description of work that has been done

**Other work related to hydraulic system**

Op. no. 070-910

This operation can be used when work has been done related to the hydraulic system and other parts related to function group 9 when no applicable method description was available. When this operation is used, additional information is required:

- Description of work that has been done

Document Title: <b>E1706</b>	Function Group: <b>080</b>	Information Type: <b>Service Information</b>	Date: <b>4/18/2026</b>
Profile: <b>L70G Volvo</b>			

### E1706

Showing Selected Profile

Valid for serial numbers			
Model	Production site	Serial number start	Serial number stop
L70G Volvo			

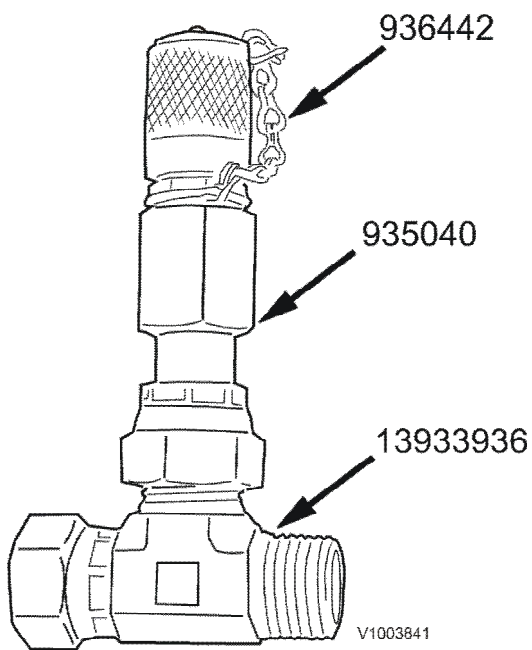

Figure 1

Document Title: <b>E 1708, Checking point</b>	Function Group: <b>080</b>	Information Type: <b>Service Information</b>	Date: <b>4/18/2026</b>
Profile: <b>L70G Volvo</b>			

### E 1708, Checking point

Showing Selected Profile

Valid for serial numbers			
Model	Production site	Serial number start	Serial number stop
L70G Volvo			

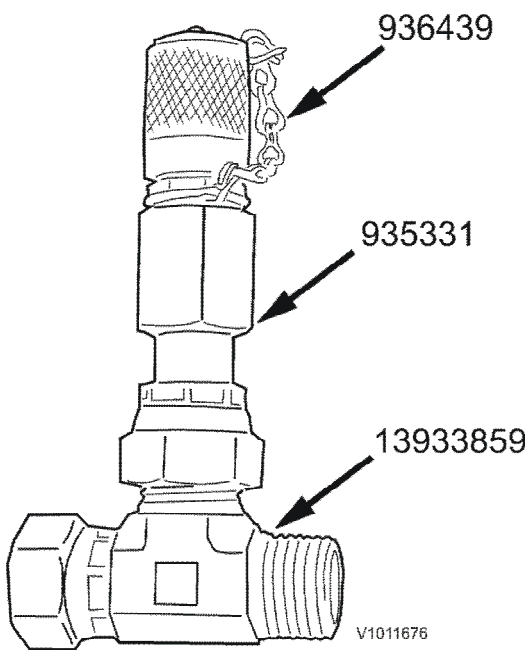

Figure 1

Document Title: <b>E1711</b>	Function Group: <b>080</b>	Information Type: <b>Service Information</b>	Date: <b>4/18/2026</b>
Profile: <b>L70G Volvo</b>			

### E1711

Showing Selected Profile

Valid for serial numbers			
Model	Production site	Serial number start	Serial number stop
L70G Volvo			

### E1711

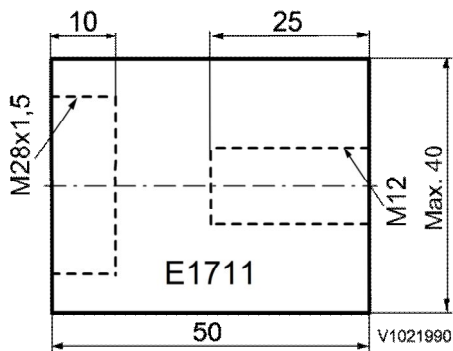

**Figure 1**

E1711

Document Title: <b>E-2000</b>	Function Group: <b>080</b>	Information Type: <b>Service Information</b>	Date: <b>4/18/2026</b>
Profile: <b>L70G Volvo</b>			

### E-2000

Showing Selected Profile

Valid for serial numbers			
Model	Production site	Serial number start	Serial number stop
L70G Volvo			

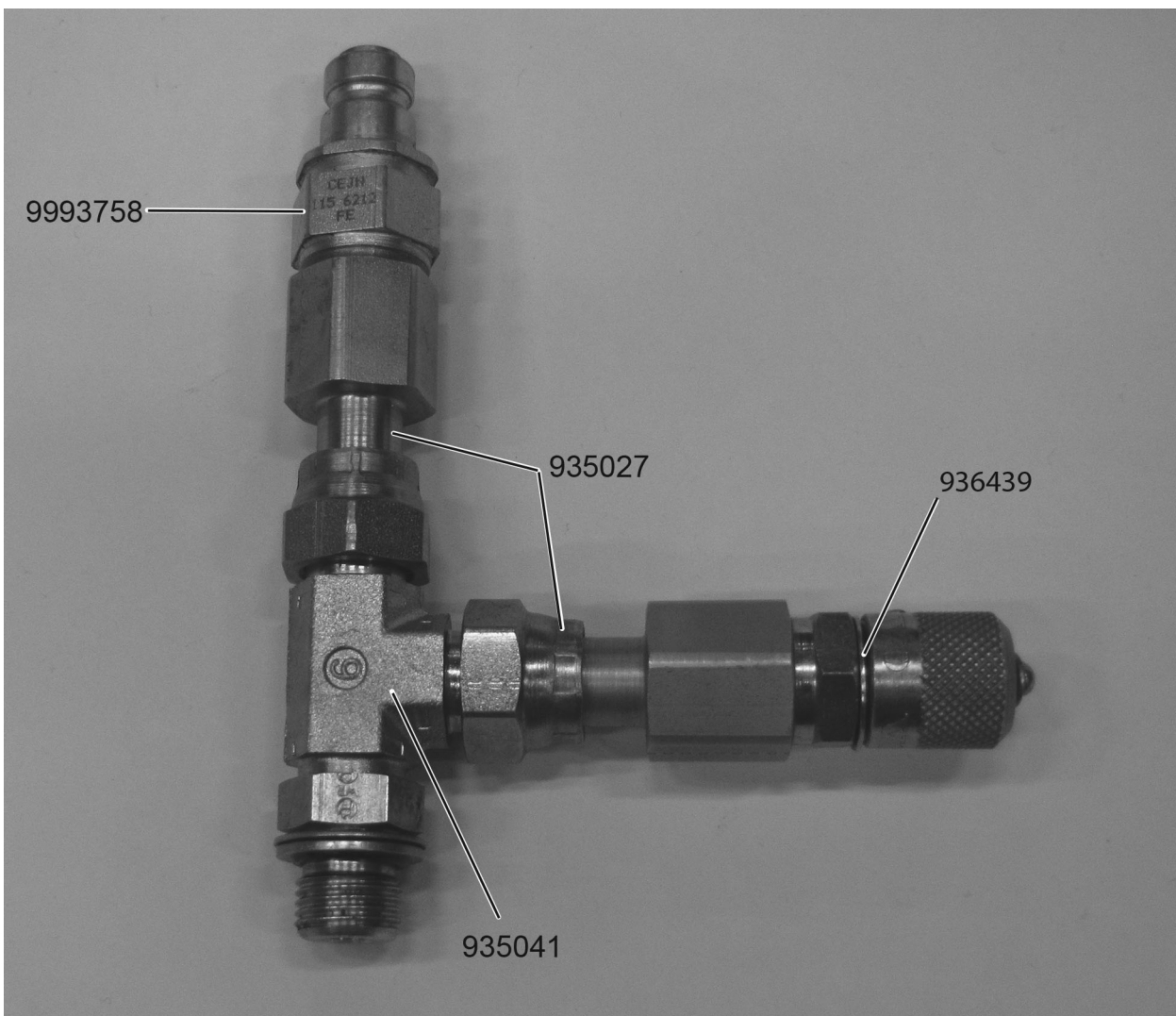

V1139126

Figure 1

Document Title: <b>E-2001</b>	Function Group: <b>080</b>	Information Type: <b>Service Information</b>	Date: <b>4/18/2026</b>
Profile: <b>L70G Volvo</b>			

### E-2001

Showing Selected Profile

Valid for serial numbers			
Model	Production site	Serial number start	Serial number stop
L70G Volvo			

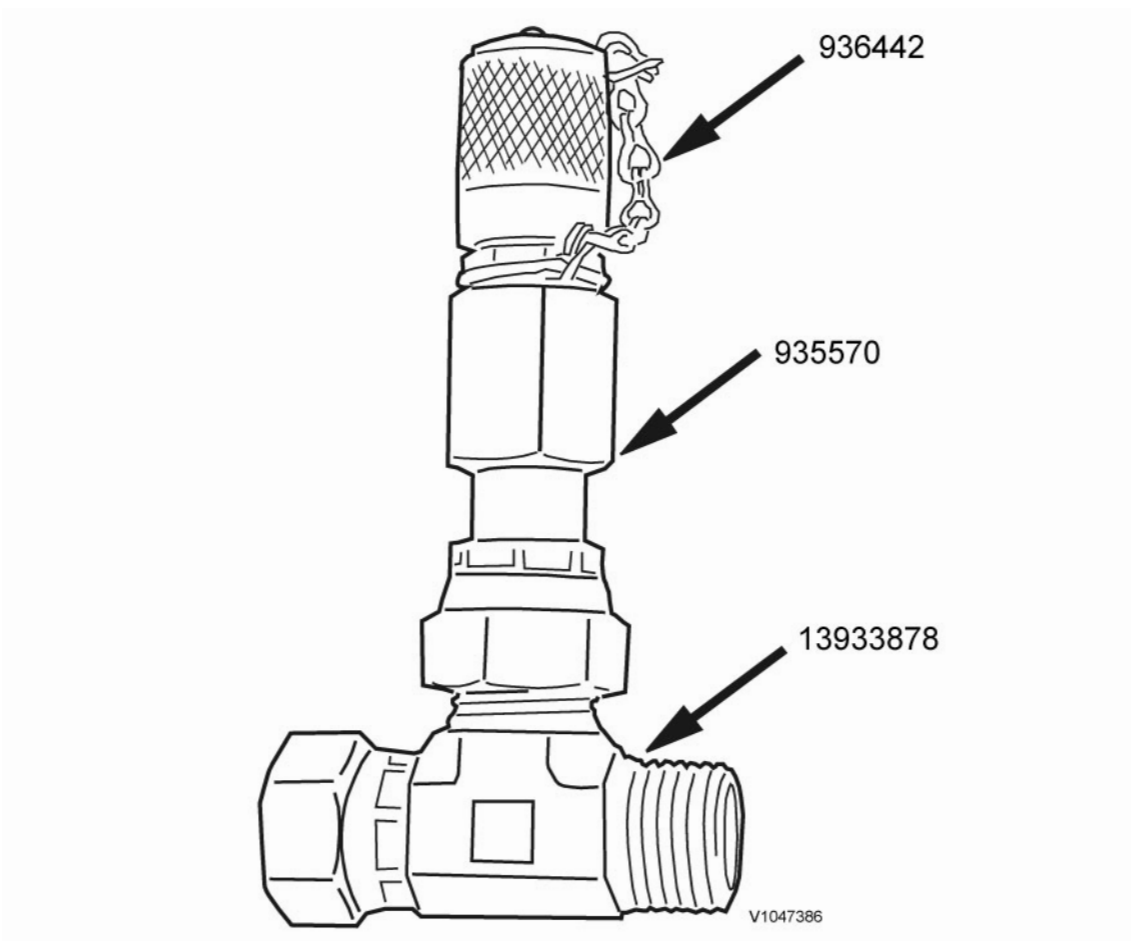

Figure 1

Document Title: <b>E-2030</b>	Function Group: <b>080</b>	Information Type: <b>Service Information</b>	Date: <b>4/18/2026</b>
Profile: <b>L70G Volvo</b>			

### E-2030

Showing Selected Profile

Valid for serial numbers			
Model	Production site	Serial number start	Serial number stop
L70G Volvo			

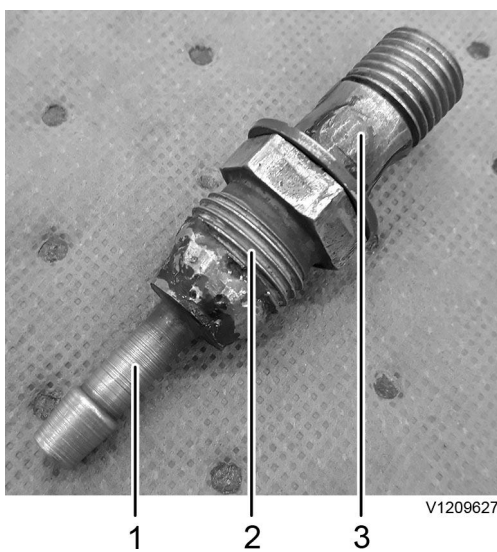

**Figure 1**

1. Hose nipple, diameter of approx. 8 mm
2. 21023622
3. Holes welded shut

Document Title: <b>E-2032</b>	Function Group: <b>080</b>	Information Type: <b>Service Information</b>	Date: <b>4/18/2026</b>
Profile: <b>L70G Volvo</b>			

### E-2032

Showing Selected Profile

Valid for serial numbers			
Model	Production site	Serial number start	Serial number stop
L70G Volvo			



**Figure 1**

1. 995895
2. Washers (2 pcs)

Document Title: <b>9993807 Lifting tool user instructions</b>	Function Group: <b>080</b>	Information Type: <b>Service Information</b>	Date: <b>4/18/2026</b>
Profile: <b>L70G Volvo</b>			

## 9993807 Lifting tool user instructions

Showing Selected Profile

Valid for serial numbers			
Model	Production site	Serial number start	Serial number stop
L70G Volvo			

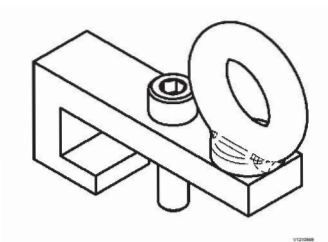

**Figure 1**

9993807 Lifting tool

### Instructions

This instruction is a guide on how to use and maintain the lifting tool correctly. The instructions must be studied carefully by the personnel concerned before the lifting tool can be put into use.

The instructions must always be available to the personnel maintaining and using the lifting tool daily.

### It is also important to:

- Keep the instructions and other applicable documents during the entire lifetime of the lifting tool.
- Pass the instructions to other owners or users of the lifting tool.
- Update the instructions with additions or changes made by the manufacturer.

Pay careful attention to information about warnings mentioned in the instructions and found on the warning signs on the lifting tools. If this information is not observed, severe personal injuries and equipment damage can arise.

### Responsibility

The instructions describe the authorized method to use the lifting tool.

The lifting tool may only be used by personnel with adequate technical training or corresponding professional experience and in consultation with the manufacturer.

If the instructions have not been followed, the manufacturer is not responsible for personal injuries or damage to equipment.

### Marking

Do not remove or make machine labels or other labels unreadable.

The lifting tool is marked with a CE mark, which means that it is designed, manufactured and described in accordance with EC Machinery Directive 2006/42/EC.

Warning decals and CE mark on lifting tool must be clearly visible. If a part provided with warning decals or CE mark is changed, a new warning decal and CE mark must be mounted in the same place. Defective decals and CE marks must be replaced immediately.



V1141218

## Figure 2

CE-marking

### Manufacturer

Company: Volvo Construction Equipment AB

Address: CE-46840, RLA 0301

Postal address: 631 85 Eskilstuna, Sweden

### Rebuilding

If the lifting tool is rebuilt or supplemented with other parts without permission by the manufacturer, the CE marking does not include this part. If such rebuilding or added parts changes the function of the lifting tool, the CE marking in its entirety is no longer valid. After rebuilding, it is important that the instructions are supplemented with the necessary illustrations, photos and texts.

### NOTE!

If not explicitly stated otherwise, always assume this instruction reference the use of two 9993807 Lifting tools.

### Intended usage

The lifting toll specified in this document is only intended for lifting torque converters with a maximum weight of 100 kg. Intended users are appointed and trained personnel, the lifting gear is not intended to be used by unauthorised or underage personnel.

To fulfil the requirements for intended use, the user must follow all instructions and maintenance directions written by the manufacturer.

### Technical data

Type designation: lifting tool for torque converter

Maximum load, lifting tool x 2: 100 kg (220 lb)

Mass, lifting tool x 2 with shackles and chain slings: 5 kg (11 lb)

Test factor for static testing (for lifting tools): 1.5

### Safety information

#### Limits of use

The lifting tools may only be used for the intended purpose. All other use is forbidden.

Lifting hooks must be equipped with a self-locking hook.

Shackles should be used for connecting the tools.

Lifting sling and straps should be marked with lifting capacity.

All accessories for the lift must have sufficient lifting capacity.

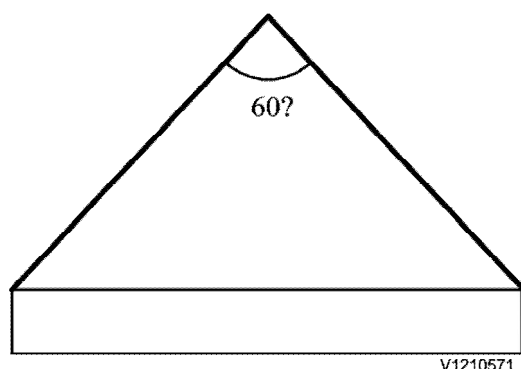

V1210571

## Figure 3

Max lift-angle

Maximum lift angles must not exceed 60°.

### Handling

To meet the requirements for intended use, the user must observe all user and maintenance instructions prescribed by the manufacturer.

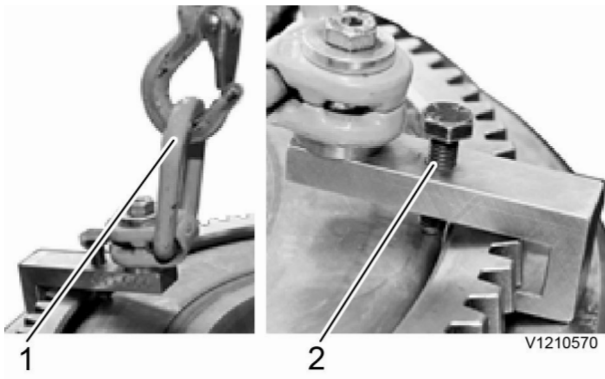

**Figure 4**

1. **Lifting equipment**  
 Use lifting sling with sufficient lifting capacity, 100 kg (220 lb).  
 Always use lifting hooks equipped with a self-locking hook.  
 Use shackles with sufficient lifting capacity, 100 kg (220 lb).
2. **Bolts**  
 Position the lifting tool under gear ring and tighten the bolts.  
 Tighten until the lifting tool is unable to move independently of the gear ring.

**Intended user**

The lifting device is intended to be used by trained personnel, it is not intended to be used by unauthorized or underage personnel.

**Conditions and preparatory measures**

Lifting tool with damaged parts must not be used.

Before lifting, check that the lifting tool does not have indications of cracks or deformations.

**Maintenance**

Maintenance must be performed by person with appropriate technical training or equivalent professional experience and in consultation with the manufacturer.

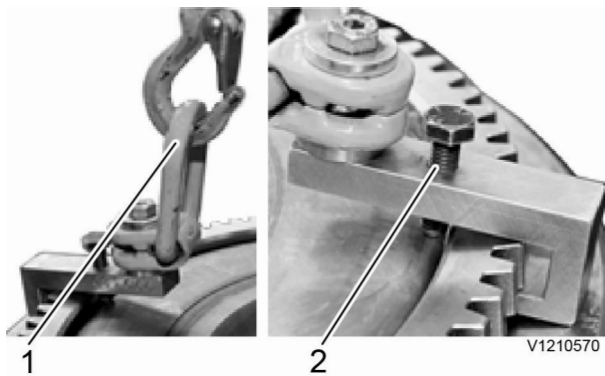

**Figure 5**

Detail/interval	Control/oversight
1 Shackles. Annual check.	Check that shackles does no have visible defects, cracks or deformations.
2 9993807 Lifting tool. Annual check.	Check that the lifting tool with threads and bolt does no have visible defects, cracks or deformations.

**General**

A defective lifting tool must be replaced.

**Workplace**

Protective shoes must be used.

The workplace should be kept free from equipment that can cause slipping or tripping risks.

The lifting tool is intended to be used in a workshop environment, outdoor usage is forbidden.

**Continuous supervision**

The lifting tool must be subjected to continuous supervision before use.

- Check for cracks.
- Check if the lifting tool is bent or deformed.
- Check that threaded screws and bolts are intact and do not have indications of breakage or deformation.

Document Title: <b>11668007 Lifting tool user instructions</b>	Function Group: <b>080</b>	Information Type: <b>Service Information</b>	Date: <b>4/18/2026</b>
Profile: <b>L70G Volvo</b>			

## 11668007 Lifting tool user instructions

Showing Selected Profile

Valid for serial numbers			
Model	Production site	Serial number start	Serial number stop
L70G Volvo			



V1210648

**Figure 1**  
11668007 lifting tool

**Instructions**

This instruction is a guide on how to use and maintain the lifting tool correctly. The instructions must be studied carefully by the personnel concerned before the lifting tool can be put into use.

The instructions must always be available to the personnel maintaining and using the lifting tool daily.

**It is also important to:**

- Keep the instructions and other applicable documents during the entire lifetime of the lifting tool.
- Pass the instructions to other owners or users of the lifting tool.
- Update the instructions with additions or changes made by the manufacturer.

Pay careful attention to information about warnings mentioned in the instructions and found on the warning signs on the lifting tools. If this information is not observed, severe personal injuries and equipment damage can arise.

**Responsibility**

The instructions describe the authorized method to use the lifting tool.

The lifting tool may only be used by personnel with adequate technical training or corresponding professional experience and in consultation with the manufacturer.

If the instructions have not been followed, the manufacturer is not responsible for personal injuries or damage to

equipment.

### Marking

Do not remove or make machine labels or other labels unreadable.

The lifting tool is marked with a CE mark, which means that it is designed, manufactured and described in accordance with EC Machinery Directive 2006/42/EC.

Warning decals and CE mark on lifting tool must be clearly visible. If a part provided with warning decals or CE mark is changed, a new warning decal and CE mark must be mounted in the same place. Defective decals and CE marks must be replaced immediately.

### Manufacturer

Company: BM Lindahl AB

Address: Älmedal 6

Postal address: 364 33 Åseda, Sweden

### Rebuilding

If the lifting tool is rebuilt or supplemented with other parts without permission by the manufacturer, the CE marking does not include this part. If such rebuilding or added parts changes the function of the lifting tool, the CE marking in its entirety is no longer valid. After rebuilding, it is important that the instructions are supplemented with the necessary illustrations, photos and texts.

### Intended usage

11668007 Lifting tool consists of stand, lifting jack, extensions and locking pins.

Intended users are appointed and trained personnel, the lifting tool is not intended to be used by unauthorized or underage personnel.

To fulfil the requirements for intended use, the user must follow all instructions and maintenance directions written by the manufacturer.

The lifting tool is only intended for lifting Volvo Wheel Loaders and Volvo Articulated Haulers. Maximum load: 15 000 kg (33 070 lb).

### Technical data

Type designation: lifting tool

Maximum load: 15 000 kg (33 070 lb), with two 11668007 lifting tools: 30 000 kg (66 140 lbs)

Mass: 78 kg (172 lb)

Test factor for static testing: For lifting tools and manually operated machines: 1.5. For other machines: 1.25

Height: 500–800 mm (19.7–31.5 in), with extensions: 600–900 mm (23.6–35.4 in)

### Safety information

#### Limits of use

The lifting tools may only be used for the intended purpose. All other use is forbidden.

For Volvo Wheel Loaders, the lifting tool is only intended to lift the rear axle.



V1071600

Always secured loads with safety pins. To stay under raised load without locking pins, is associated with life danger.



V1071600

To prevent breakage and sliding, the lifting tool must always be used with a vertical load.

To prevent oblique loads, always use two 11668007 lifting tools.

#### Handling

To meet the requirements for intended use, the user must observe all user and maintenance instructions prescribed by the manufacturer.

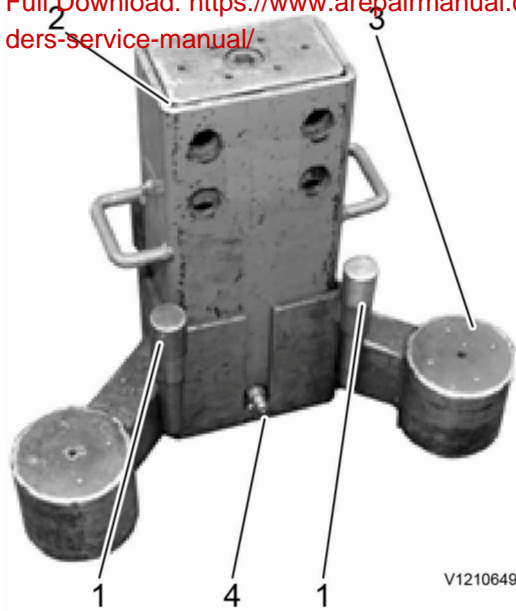

**Figure 2**

Pre use check

1. **Safety pins**  
Make sure that safety pins are supplied along with the lifting tool.  
Check that the safety pins are intact and do not have indications of breakage or deformation.
2. **Inner and outer lifting beam**  
Check that the beam with pin holes is intact and do not have indications of breakage or deformation.
3. **Support legs**  
The lifting tool has three support legs.  
Check that the stand is intact and does not have indications of breakage or deformation.
4. **Connection nipple**  
Connection nipple for pneumatic pump.

### Pneumatic pump

Check that pneumatic pump with hose kit and couplings does not have indications of breakage or deformation. Always replace defective units.

### Intended user

The lifting device is intended to be use by trained personnel, it is not intended to be used by unauthorized or underage personnel.

### Conditions and preparatory measures

Lifting tool with damaged parts must not be used.



V1071600

Make sure that there are no people in the vicinity who may be at risk when operating this lifting tool.

### Lifting



V1071600

Never stay under raised load with the safety pins disconnected.

1. **Steering linkage lock**  
Lock steering linkage with steering linkage lock.  
If an articulated hauler is being lifted, place body support.  
Connect stops.
2. **Assemble**  
Place the lifting jack into the stand.  
Make sure the nipple fits in the groove.

Sample Place the Lifting tool All 2240 pages at:

<https://www.aresairmanual.com/downloads/l70g-volvo-wheel-loaders-service-manual/>