



Document Title: <b>Volvo standard tightening torques</b>	Function Group: <b>030</b>	Information Type: <b>Service Information</b>	Date: <b>4/13/2026</b>
Profile: <b>L250H Volvo</b>			

## Volvo standard tightening torques

Showing Selected Profile

Valid for serial numbers			
Model	Production site	Serial number start	Serial number stop
L250H Volvo			

The tightening torques in the following tables apply to bolts and nuts with tensile strength. The tables should be used as a general instruction for tightening bolts and nuts without specified values. The charts contains values for course thread bolts and nuts.

Torque values should be increased with  $\approx 10\%$ , for flange bolts.

All standard torques for bolts are without surface treatment.

The standard torque for bolts lubricated with oil should be reduced with 20% of the given value.

### Standard tightening torque charts

Bolt size Metric Coarse Threads	Tensile strength 8.8		Tensile strength 10.9	
	(Nm)	(lbf ft)	(Nm)	(lbf ft)
M5	6	4	8	6
M6	10	7	14	11
M8	25	18	35	26
M10	50	37	70	52
M12	87	64	122	90
M14	139	103	195	144
M16	213	157	299	220
M18	293	216	413	305
M20	416	307	585	432
M24	719	530	1010	745
M27	1060	782	1490	1100
M30	1140	840	2025	1493
M36	2500	1844	3600	2653

Bolt size Inch SAE Coarse Threads	Tensile strength 5		Tensile strength 8	
	(lbf ft)	(Nm)	(lbf ft)	(Nm)
1/4	10	13,6	14	19
5/16	21	28,5	29	39,3
3/8	37	50,2	52	70
7/16	59	80	84	114
1/2	90	122	128	174
9/16	130	176	184	250
5/8	200	271	284	388
3/4	270	365	384	520
7/8	340	460	484	655
1	410	550	584	790
1 1/8	500	675	712	955
1 1/4	590	800	848	1135
1 3/8	680	920	976	1325
1 1/2	770	1045	1104	1505
1 3/4	860	1165	1232	1675
2	950	1285	1360	1845
2 1/4	1140	1545	1632	2205
2 3/4	1330	1805	1920	2595
3	1520	2060	2208	2985
3 1/2	1710	2315	2496	3375
4	1900	2570	2784	3765
4 1/2	2090	2825	3072	4155
5	2280	3080	3360	4545
5 1/2	2470	3335	3648	4935
6	2660	3590	3936	5325
6 1/2	2850	3845	4224	5715
7	3040	4100	4512	6105
7 1/2	3230	4355	4800	6495
8	3420	4610	5088	6885
8 1/2	3610	4865	5376	7275
9	3800	5120	5664	7665
9 1/2	3990	5375	5952	8055
10	4180	5630	6240	8445
10 1/2	4370	5885	6528	8835
11	4560	6140	6816	9225
11 1/2	4750	6395	7104	9615
12	4940	6650	7392	10005
12 1/2	5130	6905	7680	10395
13	5320	7160	7968	10785
13 1/2	5510	7415	8256	11175
14	5700	7670	8544	11565
14 1/2	5890	7925	8832	11955
15	6080	8180	9120	12345
15 1/2	6270	8435	9408	12735
16	6460	8690	9696	13125
16 1/2	6650	8945	9984	13515
17	6840	9200	10272	13905
17 1/2	7030	9455	10560	14295
18	7220	9710	10848	14685
18 1/2	7410	9965	11136	15075
19	7600	10220	11424	15465
19 1/2	7790	10475	11712	15855
20	7980	10730	12000	16245
20 1/2	8170	10985	12288	16635
21	8360	11240	12576	17025
21 1/2	8550	11495	12864	17415
22	8740	11750	13152	17805
22 1/2	8930	12005	13440	18195
23	9120	12260	13728	18585
23 1/2	9310	12515	14016	18975
24	9500	12770	14304	19365
24 1/2	9690	13025	14592	19755
25	9880	13280	14880	20145
25 1/2	10070	13535	15168	20535
26	10260	13790	15456	20925
26 1/2	10450	14045	15744	21315
27	10640	14300	16032	21705
27 1/2	10830	14555	16320	22095
28	11020	14810	16608	22485
28 1/2	11210	15065	16896	22875
29	11400	15320	17184	23265
29 1/2	11590	15575	17472	23655
30	11780	15830	17760	24045
30 1/2	11970	16085	18048	24435
31	12160	16340	18336	24825
31 1/2	12350	16595	18624	25215
32	12540	16850	18912	25605
32 1/2	12730	17105	19200	25995
33	12920	17360	19488	26385
33 1/2	13110	17615	19776	26775
34	13300	17870	20064	27165
34 1/2	13490	18125	20352	27555
35	13680	18380	20640	27945
35 1/2	13870	18635	20928	28335
36	14060	18890	21216	28725
36 1/2	14250	19145	21504	29115
37	14440	19400	21792	29505
37 1/2	14630	19655	22080	29895
38	14820	19910	22368	30285
38 1/2	15010	20165	22656	30675
39	15200	20420	22944	31065
39 1/2	15390	20675	23232	31455
40	15580	20930	23520	31845
40 1/2	15770	21185	23808	32235
41	15960	21440	24096	32625
41 1/2	16150	21695	24384	33015
42	16340	21950	24672	33405
42 1/2	16530	22205	24960	33795
43	16720	22460	25248	34185
43 1/2	16910	22715	25536	34575
44	17100	22970	25824	34965
44 1/2	17290	23225	26112	35355
45	17480	23480	26400	35745
45 1/2	17670	23735	26688	36135
46	17860	23990	26976	36525
46 1/2	18050	24245	27264	36915
47	18240	24500	27552	37305
47 1/2	18430	24755	27840	37695
48	18620	25010	28128	38085
48 1/2	18810	25265	28416	38475
49	19000	25520	28704	38865
49 1/2	19190	25775	28992	39255
50	19380	26030	29280	39645
50 1/2	19570	26285	29568	40035
51	19760	26540	29856	40425
51 1/2	19950	26795	30144	40815
52	20140	27050	30432	41205
52 1/2	20330	27305	30720	41595
53	20520	27560	31008	41985
53 1/2	20710	27815	31296	42375
54	20900	28070	31584	42765
54 1/2	21090	28325	31872	43155
55	21280	28580	32160	43545
55 1/2	21470	28835	32448	43935
56	21660	29090	32736	44325
56 1/2	21850	29345	33024	44715
57	22040	29600	33312	45105
57 1/2	22230	29855	33600	45495
58	22420	30110	33888	45885
58 1/2	22610	30365	34176	46275
59	22800	30620	34464	46665
59 1/2	22990	30875	34752	47055
60	23180	31130	35040	47445
60 1/2	23370	31385	35328	47835
61	23560	31640	35616	48225
61 1/2	23750	31895	35904	48615
62	23940	32150	36192	49005
62 1/2	24130	32405	36480	49395
63	24320	32660	36768	49785
63 1/2	24510	32915	37056	50175
64	24700	33170	37344	50565
64 1/2	24890	33425	37632	50955
65	25080	33680	37920	51345
65 1/2	25270	33935	38208	51735
66	25460	34190	38496	52125
66 1/2	25650	34445	38784	52515
67	25840	34700	39072	52905
67 1/2	26030	34955	39360	53295
68	26220	35210	39648	53685
68 1/2	26410	35465	39936	54075
69	26600	35720	40224	54465
69 1/2	26790	35975	40512	54855
70	26980	36230	40800	55245
70 1/2	27170	36485	41088	55635
71	27360	36740	41376	56025
71 1/2	27550	36995	41664	56415
72	27740	37250	41952	56805
72 1/2	27930	37505	42240	57195
73	28120	37760	42528	57585
73 1/2	28310	38015	42816	57975
74	28500	38270	43104	58365
74 1/2	28690	38525	43392	58755
75	28880	38780	43680	59145
75 1/2	29070	39035	43968	59535
76	29260	39290	44256	59925
76 1/2	29450	39545	44544	60315
77	29640	39800	44832	60705
77 1/2	29830	40055	45120	61095
78	30020	40310	45408	61485
78 1/2	30210	40565	45696	61875
79	30400	40820	45984	62265
79 1/2	30590	41075	46272	62655
80	30780	41330	46560	63045
80 1/2	30970	41585	46848	63435
81	31160	41840	47136	63825
81 1/2	31350	42095	47424	64215
82	31540	42350	47712	64605
82 1/2	31730	42605	48000	64995
83	31920	42860	48288	65385
83 1/2	32110	43115	48576	65775
84	32300	43370	48864	66165
84 1/2	32490	43625	49152	66555
85	32680	43880	49440	66945
85 1/2	32870	44135	49728	67335
86	33060	44390	50016	67725
86 1/2	33250	44645	50304	68115
87	33440	44900	50592	68505
87 1/2	33630	45155	50880	68895
88	33820	45410	51168	69285
88 1/2	34010	45665	51456	69675
89	34200	45920	51744	70065
89 1/2	34390	46175	52032	70455
90	34580	46430	52320	70845
90 1/2	34770	46685	52608	71235
91	34960	46940	52896	71625
91 1/2	35150	47195	53184	72015
92	35340	47450	53472	72405
92 1/2	35530	47705	53760	72795
93	35720	47960	54048	73185
93 1/2	35910	48215	54336	73575
94	36100	48470	54624	73965
94 1/2	36290	48725	54912	74355
95				

Product: L250H Volvo Wheel Loaders Service Manual

Full Download: <https://www.arepairmanual.com/downloads/l250h-volvo-wheel-loaders-service-manual/>

3/4	320	434	451	612
7/8	515	700	728	988
1	775	1052	1091	1480
1 1/8	953	1290	1545	2100
1 1/4	1344	1823	2180	2960
1 3/8	1600	2170	2650	3600
1 1/2	2000	2714	3200	4340

Sample manual. Download All 3502 pages at:

<https://www.arepairmanual.com/downloads/l250h-volvo-wheel-loaders-service-manual/>

Document Title: <b>Conversion tables</b>	Function Group: <b>030</b>	Information Type: <b>Service Information</b>	Date: <b>4/13/2026</b>
Profile: <b>L250H Volvo</b>			

## Conversion tables

Showing Selected Profile

Valid for serial numbers			
Model	Production site	Serial number start	Serial number stop
L250H Volvo			

### Length

Unit	cm	m	km	in	ft	yd	mile
cm	1	0.01	0.00001	0.3937	0.03281	0.01094	0.000006
m	100	1	0.001	39.37	3.2808	1.0936	0.00062
km	100000	1000	1	39370.7	3280.8	1093.6	0.62137
in	2.54	0.0254	0.000025	1	0.08333	0.02777	0.000015
ft	30.48	0.3048	0.000304	12	1	0.3333	0.000189
yd	91.44	0.9144	0.000914	36	3	1	0.000568
mile	160930	1609.3	1.6093	63360	5280	1760	1

1 mm = 0.1 cm - 1 mm = 0.001 m

### Area

Unit	cm <sup>2</sup>	m <sup>2</sup>	km <sup>2</sup>	a	ft <sup>2</sup>	yd <sup>2</sup>	in <sup>2</sup>
cm <sup>2</sup>	1	0.0001	-	0.000001	0.001076	0.000012	0.155000
m <sup>2</sup>	10000	1	0.000001	0.01	10.764	1.1958	1550.000
km <sup>2</sup>	-	1000000	1	10000	1076400	1195800	-
a	0.01	100	0.0001	1	1076.4	119.58	-
ft <sup>2</sup>	-	0.092903	-	0.000929	1	0.1111	144.000
yd <sup>2</sup>	-	0.83613	-	0.008361	9	1	1296.00
in <sup>2</sup>	6.4516	0.000645	-	-	0.006943	0.000771	1

1 ha = 100 a - 1 mile<sup>2</sup> = 259 ha = 2.59 km<sup>2</sup>

### Volume

Unit	cm <sup>3</sup> = cc	m <sup>3</sup>	l	in <sup>3</sup>	ft <sup>3</sup>	yd <sup>3</sup>
cm <sup>3</sup> = ml	1	0.000001	0.001	0.061024	0.000035	0.000001
m <sup>3</sup>	1000000	1	1000	61024	35.315	1.30796
dm <sup>3</sup> (l)	1000	0.001	1	61.024	0.035315	0.001308
in <sup>3</sup>	16.387	0.000016	0.01638	1	0.000578	0.000021
ft <sup>3</sup>	28316.8	0.028317	28.317	1728	1	0.03704
yd <sup>3</sup>	764529.8	0.76453	764.53	46656	27	1

1 gal (US) = 3785.41 cm<sup>3</sup> = 231 in<sup>3</sup> = 0.83267 gal (UK)

### Weight

Unit	g	kg	t	oz	lb
g	1	0.001	0.000001	0.03527	0.0022
kg	1000	1	0.001	35.273	2.20459
t	1000000	1000	1	35273	2204.59
oz	28.3495	0.02835	0.000028	1	0.0625
lb	453.592	0.45359	0.000454	16	1

1 ton (metric) = 1.1023 ton (US) = 0.9842 ton (UK)

### Pressure

Unit	kp/cm <sup>2</sup>	bar	Pa=N/m <sup>2</sup>	kPa	lbf/in <sup>2</sup>	lbf/ft <sup>2</sup>
kp/cm <sup>2</sup>	1	0.98067	98066.5	98.0665	14.2233	2048.16
bar	1.01972	1	100000	100	14.5037	2088.6
Pa=N/m <sup>2</sup>	0.00001	0.001	1	0.001	0.00015	0.02086
kPa	0.01020	0.01	1000	1	0.14504	20.886
lbf/in <sup>2</sup>	0.07032	0.0689	6894.76	6.89476	1	144
lbf/ft <sup>2</sup>	0.00047	0.00047	47.88028	0.04788	0.00694	1

kg/cm<sup>2</sup> = 735.56 Dry (mmHg) = 0.96784 atm

### Unit explanations

Unit	abbreviation
Newton meter	Nm
Kilopoundmeter	kpm
Kilopascal	kPa
Megapascal	MPa
Kilowatt	kW
kilojoule	kJ
British thermal unit	Btu
Calorie	cal

### Approx. conversion

SI unit	Conversion factor	Non SI	Conversion factor	SI
<b>Torque</b>				
Nm	x10.2	=kg/cm	x0.8664	=lb in
Nm	x0.74	=lbf-ft	x1.36	=Nm
Nm	x0.102	=kg/m	x7.22	=lbft
<b>Pressure (Pa = N/m<sup>2</sup>)</b>				
kPa	x4.0	=in.H <sub>2</sub> O	x0.249	=kPa
kPa	x0.30	=in.Hg	x3.38	=kPa
kPa	x0.145	=psi	x6.89	=kPa
bar	x14.5	=psi	x0.069	=bar
kp/cm <sup>2</sup>	x14.22	=psi	x0.070	=kp/cm <sup>2</sup>
N/mm <sup>2</sup>	x145.04	=psi	x0.069	=bar
MPa	x145	=psi	x0.00689	=MPa
<b>Power (W = J/s)</b>				
kW	x1.36	=hp(cv)	x0.736	=kW

kW	x1.34	= bhp	x0.746	= kW
kW	x0.948	= Btu/s	x1.055	= kW
W	x0.74	= ft-lb/s	x1.36	= W
Energy (J = Nm)				
kJ	x0.948	= Btu	x1.055	= kJ
J	x0.239	= calorie	x4.19	= J
Speed and acceleration				
m/s <sup>2</sup>	x3.28	= ft/s <sup>2</sup>	x0.305	= m/s <sup>2</sup>
m/s	x3.28	= ft/s	x0.305	= m/s
km/h	x0.62	= mph	x1.61	= km/h
Horsepower/torque				
Bhp x5252 rpm = TQ (lb-ft)			TQ x rpm 5252 = bhp	
Temperature				
$^{\circ}\text{C} = (^{\circ}\text{F} - 32) / 1.8$			$^{\circ}\text{F} = (^{\circ}\text{C} \times 1.8) + 32$	
Flow factor				
l/min (dm <sup>3</sup> /min)	x0.264	= US gal/min	x3.785	= liter/min

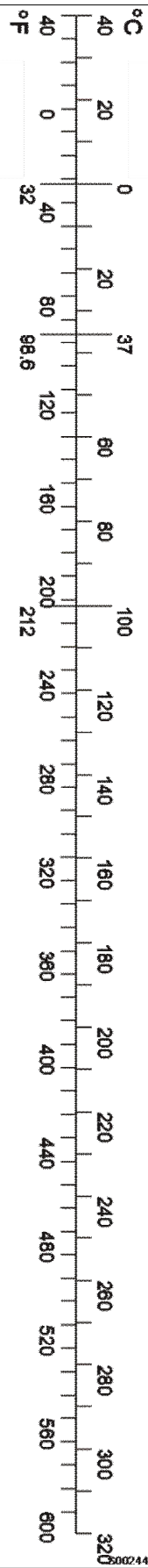

Document Title: <b>Torque wrench extension</b>	Function Group: <b>030</b>	Information Type: <b>Service Information</b>	Date: <b>4/13/2026</b>
Profile: <b>L250H Volvo</b>			

## Torque wrench extension

Showing Selected Profile

Valid for serial numbers			
Model	Production site	Serial number start	Serial number stop
L250H Volvo			

When an extension is used together with a torque wrench (e.g.88830381 Wrench), the torque applied to the screw increases since the lever arm is extended.

The following formula is used to calculate the correct torque wrench settings:

$$M1 = M2 \times (L1/L2)$$

**M1** is the torque to be set on the torque wrench.

**L1** is the normal length of the torque wrench.

**M2** is the tightening torque according to specification.

**L2** is the total length of the torque wrench and extension.

### NOTE!

The extension and the torque wrench must be in a straight line for the calculation to be correct.

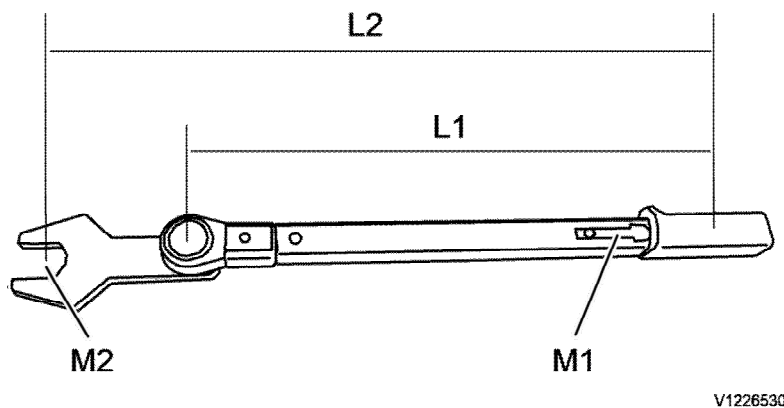

**Figure 1**

### Calculation example

M1 is the torque to be set on the torque wrench.

M2 is the tightening torque according to specification, e.g. 100 Nm.

L1 is the measured length of the torque wrench, e.g. 45 cm.

L2 is the measured length of the extension and the torque wrench, e.g. 60 cm.

L1 = 45 cm

L2 = 60 cm

M2 = 100 Nm

$$M1 = 100 \text{ Nm} \times (45 \text{ cm}/60 \text{ cm}) = 75 \text{ Nm}$$

Document Title: <b>Operation numbers for additional work</b>	Function Group: <b>070</b>	Information Type: <b>Service Information</b>	Date: <b>4/13/2026</b>
Profile: <b>Wheel Loaders (WLO)</b>			

## Operation numbers for additional work

Showing Selected Profile

These operations can be used to identify work that is not included in the time guide or described in the methods in the Service Manual. When these operations are used, a description of the work that has been performed must be provided.

### Other work related to engine

Op. no. 070-210

This operation can be used when work has been done related to the engine and function group 2 when no applicable method description was available. When this operation is used, additional information is required:

- Description of work that has been done

### Other work related to electrical system

Op. no. 070-310

This operation can be used when work has been done related to the electrical system and function group 3 when no applicable method description was available. When this operation is used, additional information is required:

- Description of work that has been done

### Other work related to transmission, gearbox, travel motor, swing motor

Op. no. 070-410

This operation can be used when work has been done related to the transmission, gearbox, travel motor or swing motor and function group 4 when no applicable method description was available. When this operation is used, additional information is required:

- Description of work that has been done

### Other work related to drive axle

Op. no. 070-470

This operation can be used when work has been done related to the drive axle and function group 46 when no applicable method description was available. When this operation is used, additional information is required:

- Description of required work that have been done

### Other work related to brake system

Op. no. 070-510

This operation can be used when work has been done related to the brake system and function group 5 when no applicable

method description was available. When this operation is used, additional information is required:

- Description of work that has been done

**Other work related to steering system**

Op. no. 070-610

This operation can be used when work has been done related to the steering system and function group 6 when no applicable method description was available. When this operation is used, additional information is required:

- Description of work that has been done

**Other work related to frame link, axle suspension**

Op. no. 070-710

This operation can be used when work has been done related to the frame link, axle suspension and other parts related to function group 7 when no applicable method description was available. When this operation is used, additional information is required:

- Description of work that has been done

**Other work related to cab, air conditioning**

Op. no. 070-810

This operation can be used when work has been done related to the cab, air conditioning and other parts related to function group 8 when no applicable method description was available. When this operation is used, additional information is required:

- Description of work that has been done

**Other work related to hydraulic system**

Op. no. 070-910

This operation can be used when work has been done related to the hydraulic system and other parts related to function group 9 when no applicable method description was available. When this operation is used, additional information is required:

- Description of work that has been done

Document Title: <b>E1680, Holder</b>	Function Group: <b>080</b>	Information Type: <b>Service Information</b>	Date: <b>4/13/2026</b>
Profile: <b>L250H Volvo</b>			

### E1680, Holder

Showing Selected Profile

Valid for serial numbers			
Model	Production site	Serial number start	Serial number stop
L250H Volvo			

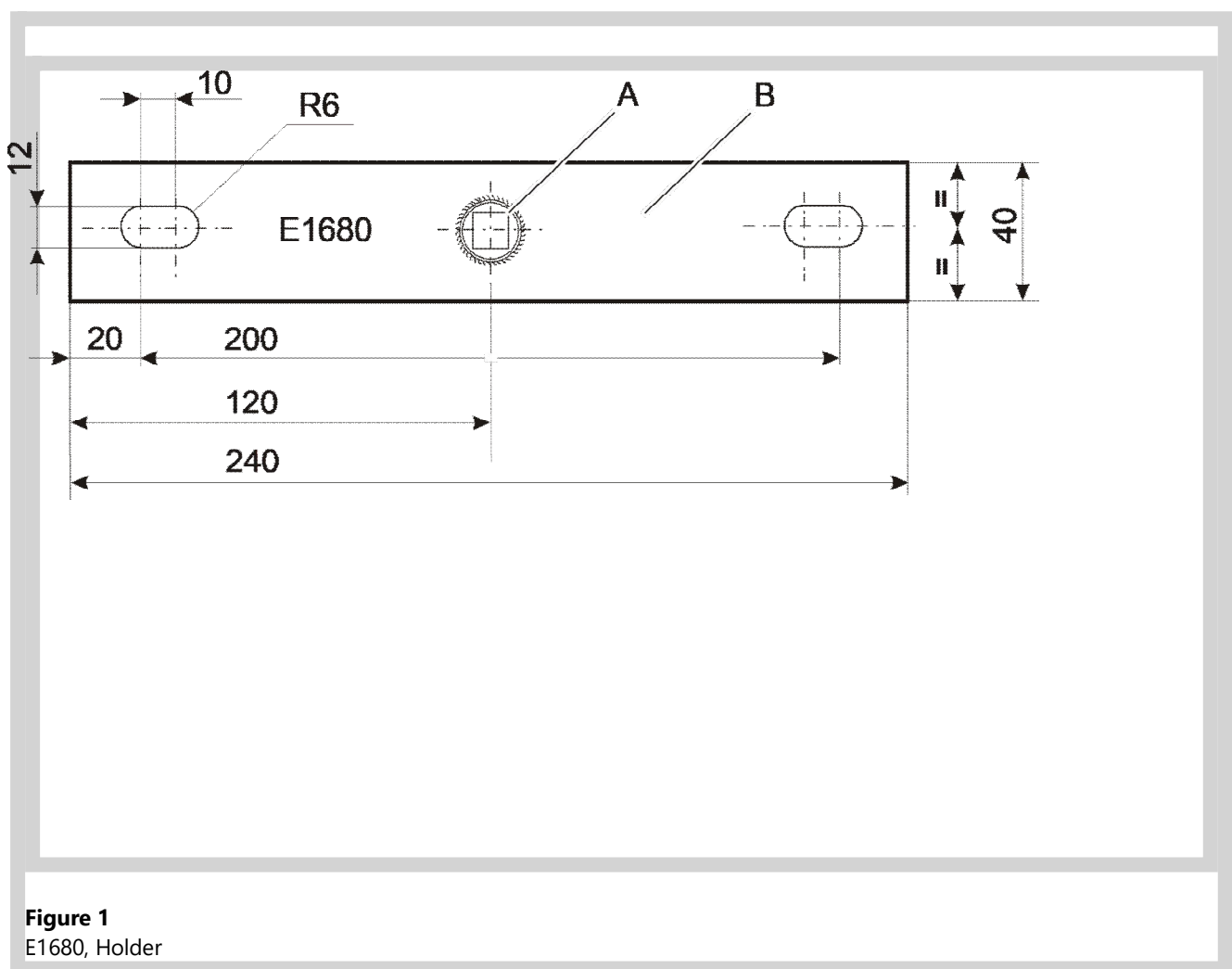

**Figure 1**  
E1680, Holder

A	1/2" Socket
B	Flat iron bar 5 mm

Document Title: <b>E 1708, Checking point</b>	Function Group: <b>080</b>	Information Type: <b>Service Information</b>	Date: <b>4/13/2026</b>
Profile: <b>L250H Volvo</b>			

### E 1708, Checking point

Showing Selected Profile

Valid for serial numbers			
Model	Production site	Serial number start	Serial number stop
L250H Volvo			

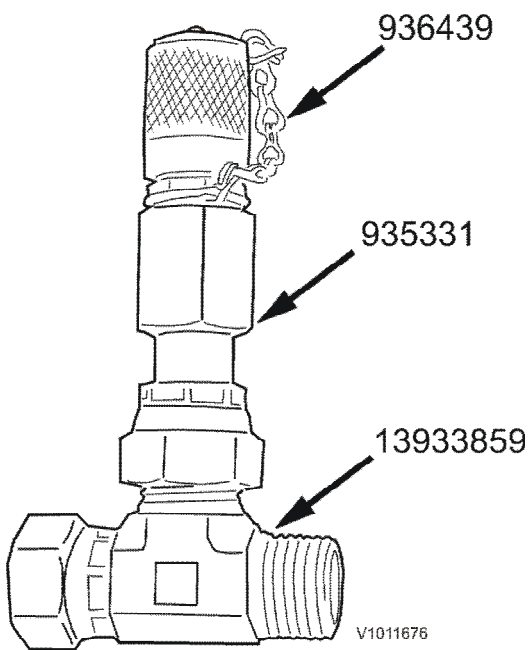

Figure 1

Document Title: <b>E1711</b>	Function Group: <b>080</b>	Information Type: <b>Service Information</b>	Date: <b>4/13/2026</b>
Profile: <b>L250H Volvo</b>			

### E1711

Showing Selected Profile

Valid for serial numbers			
Model	Production site	Serial number start	Serial number stop
L250H Volvo			

### E1711

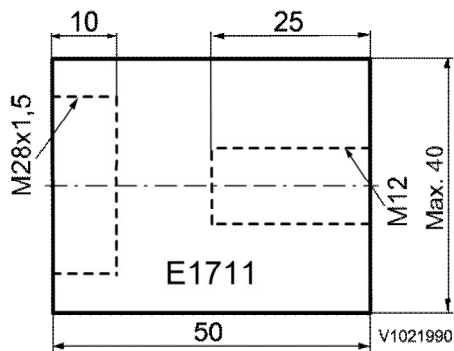

**Figure 1**

E1711

Document Title: <b>E-2001</b>	Function Group: <b>080</b>	Information Type: <b>Service Information</b>	Date: <b>4/13/2026</b>
Profile: <b>L250H Volvo</b>			

### E-2001

Showing Selected Profile

Valid for serial numbers			
Model	Production site	Serial number start	Serial number stop
L250H Volvo			

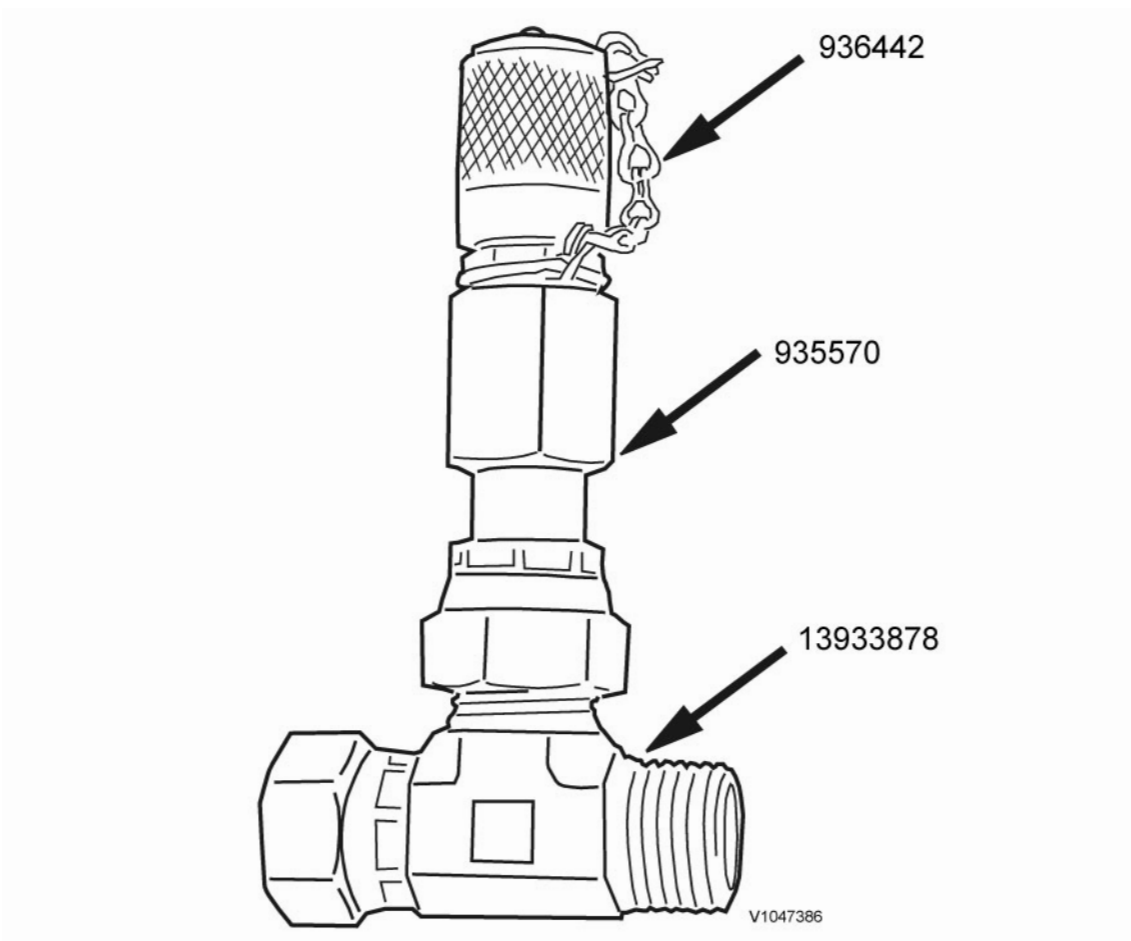

Figure 1

Document Title: <b>E-2005</b>	Function Group: <b>080</b>	Information Type: <b>Service Information</b>	Date: <b>4/13/2026</b>
Profile: <b>L250H Volvo</b>			

## E-2005

Showing Selected Profile

Valid for serial numbers			
Model	Production site	Serial number start	Serial number stop
L250H Volvo			

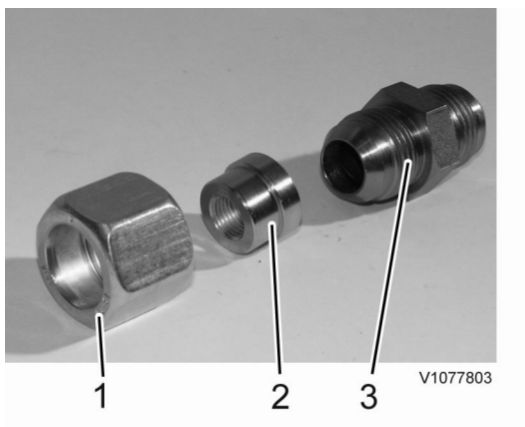

**Figure 1**

E-tool 2005

1. Coupling nut 931206
2. Test nipple 11054368 Thread R1/4"
3. Nipple 929315

Document Title: <b>E-2007</b>	Function Group: <b>080</b>	Information Type: <b>Service Information</b>	Date: <b>4/13/2026</b>
Profile: <b>L250H Volvo</b>			

### E-2007

Showing Selected Profile

Valid for serial numbers			
Model	Production site	Serial number start	Serial number stop
L250H Volvo			



Figure 1

Document Title: <b>E-2014</b>	Function Group: <b>080</b>	Information Type: <b>Service Information</b>	Date: <b>4/13/2026</b>
Profile: <b>L250H Volvo</b>			

### E-2014

Showing Selected Profile

Valid for serial numbers			
Model	Production site	Serial number start	Serial number stop
L250H Volvo			

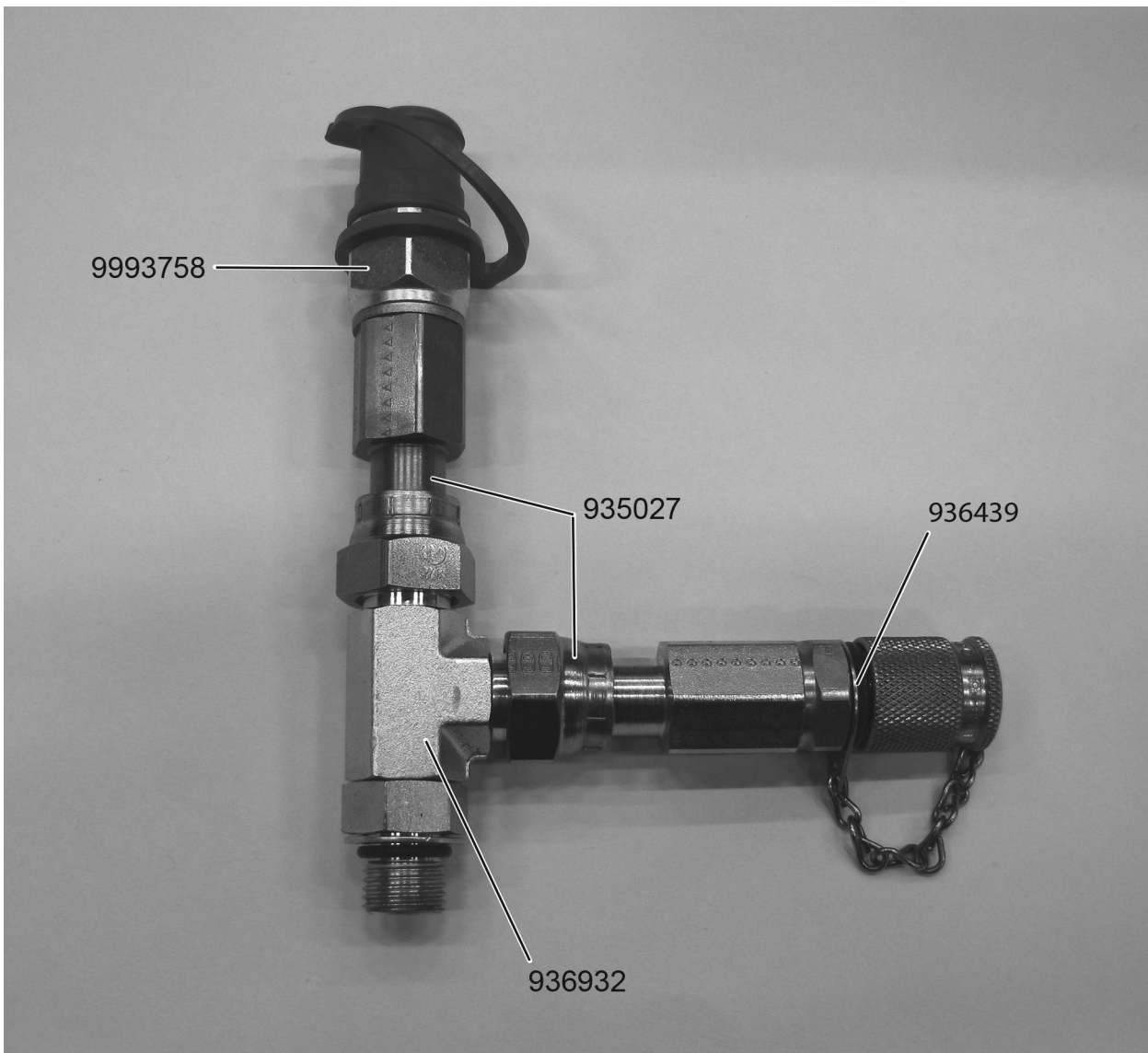

V1138633

Figure 1

Document Title: <b>E-2015</b>	Function Group: <b>080</b>	Information Type: <b>Service Information</b>	Date: <b>4/13/2026</b>
Profile: <b>L250H Volvo</b>			

### E-2015

Showing Selected Profile

Valid for serial numbers			
Model	Production site	Serial number start	Serial number stop
L250H Volvo			

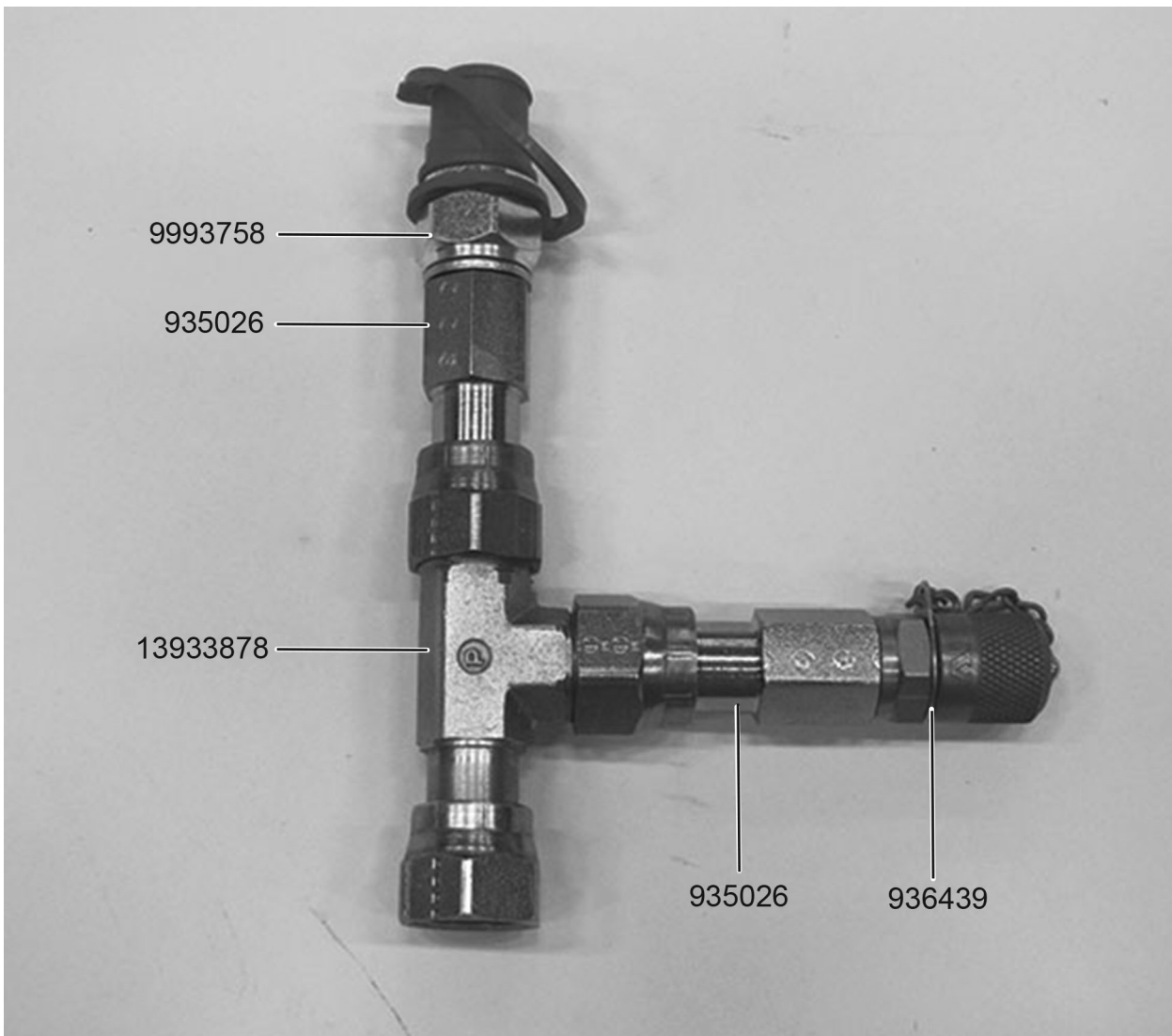

V1138746

Figure 1

Document Title: <b>E-2016</b>	Function Group: <b>080</b>	Information Type: <b>Service Information</b>	Date: <b>4/13/2026</b>
Profile: <b>L250H Volvo</b>			

### E-2016

Showing Selected Profile

Valid for serial numbers			
Model	Production site	Serial number start	Serial number stop
L250H Volvo			

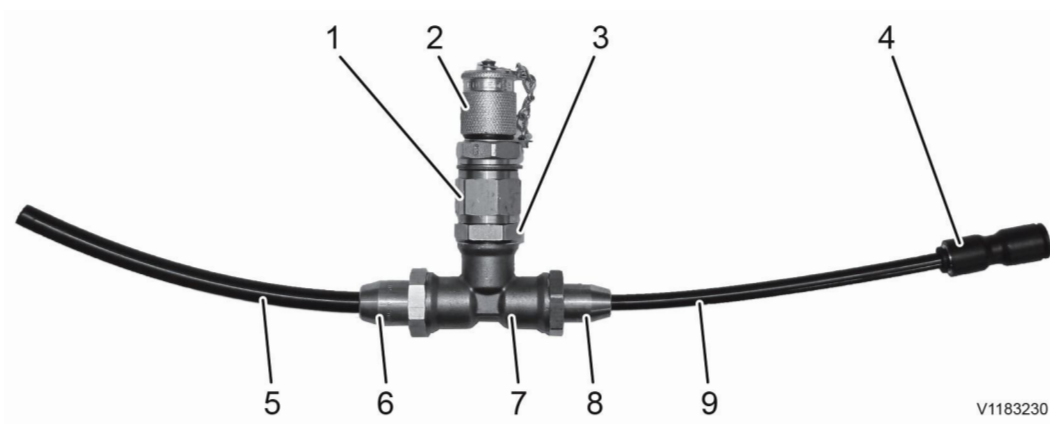

V1183230

**Figure 1**

1. 88830130 Nipple
2. 15018967 Testing nipple
3. 11196161 Nipple
4. 17413665 Connector Ø 6/8 mm
5. 980832 Tube Ø 8 mm
6. 977789 Fitting Ø 8 mm
7. 15023142 T-coupling
8. 979282 Fitting Ø 6 mm
9. 980831 Tube Ø 6mm

Document Title: <b>E-2017</b>	Function Group: <b>080</b>	Information Type: <b>Service Information</b>	Date: <b>4/13/2026</b>
Profile: <b>L250H Volvo</b>			

### E-2017

Showing Selected Profile

Valid for option/configuration			
Model	Option no.	Option	Configuration
L250H Volvo	85625	Engine	D13J EU Stage IV
L250H Volvo	85626	Engine	D13J US Tier 4 final
L250H Volvo	87258	Engine	D13J US Tier 4 final

Valid for serial numbers			
Model	Production site	Serial number start	Serial number stop
L250H Volvo	Arvika	1001	6000

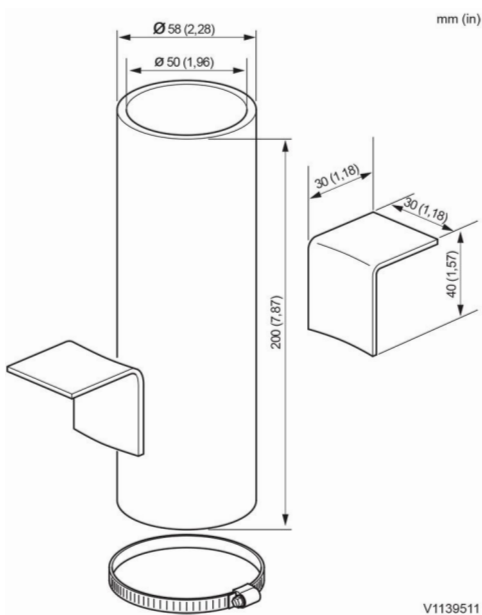

Figure 1

Document Title: <b>E-2018</b>	Function Group: <b>080</b>	Information Type: <b>Service Information</b>	Date: <b>4/13/2026</b>
Profile: <b>L250H Volvo</b>			

## E-2018

Showing Selected Profile

Valid for serial numbers			
Model	Production site	Serial number start	Serial number stop
L250H Volvo			

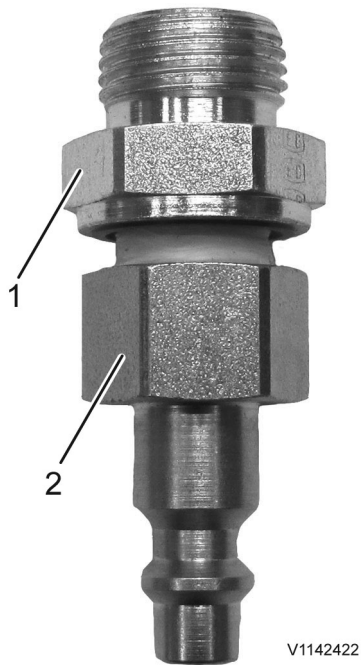

**Figure 1**

1. 963948
2. 17420996

Document Title: <b>E-2037</b>	Function Group: <b>080</b>	Information Type: <b>Service Information</b>	Date: <b>4/13/2026</b>
Profile: <b>L250H Volvo</b>			

### E-2037

Showing Selected Profile

Valid for option/configuration			
Model	Option no.	Option	Configuration
L250H Volvo	85625	Engine	D13J EU Stage IV
L250H Volvo	85626	Engine	D13J US Tier 4 final
L250H Volvo	87258	Engine	D13J US Tier 4 final

Valid for serial numbers			
Model	Production site	Serial number start	Serial number stop
L250H Volvo	Arvika	1001	6000

#### Plate

Dimensions on the drawing are given in mm.

E-2037

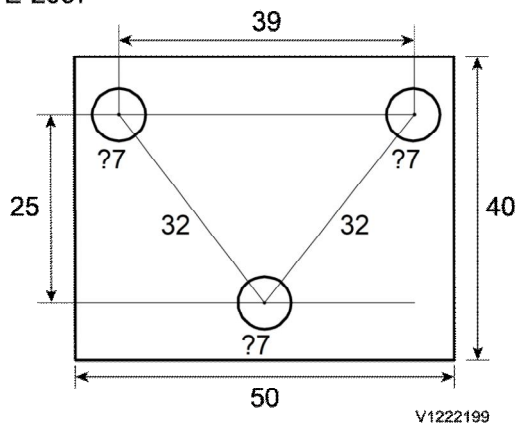

**Figure 1**

E-2037

Flat iron bar, thickness 6 mm

Document Title: <b>E-2045</b>	Function Group: <b>080</b>	Information Type: <b>Service Information</b>	Date: <b>4/13/2026</b>
Profile: <b>L250H Volvo</b>			

### E-2045

Showing Selected Profile

Valid for serial numbers			
Model	Production site	Serial number start	Serial number stop
L250H Volvo			

#### Installation tool

Dimensions on the drawing are given in mm.

### E-2045

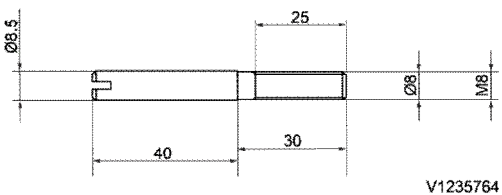

**Figure 1**

Material: S235JR

Document Title: <b>9993807 Lifting tool user instructions</b>	Function Group: <b>080</b>	Information Type: <b>Service Information</b>	Date: <b>4/13/2026</b>
Profile: <b>L250H Volvo</b>			

## 9993807 Lifting tool user instructions

Showing Selected Profile

Valid for serial numbers			
Model	Production site	Serial number start	Serial number stop
L250H Volvo			

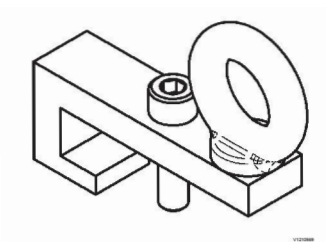

**Figure 1**

9993807 Lifting tool

### Instructions

This instruction is a guide on how to use and maintain the lifting tool correctly. The instructions must be studied carefully by the personnel concerned before the lifting tool can be put into use.

The instructions must always be available to the personnel maintaining and using the lifting tool daily.

### It is also important to:

- Keep the instructions and other applicable documents during the entire lifetime of the lifting tool.
- Pass the instructions to other owners or users of the lifting tool.
- Update the instructions with additions or changes made by the manufacturer.

Pay careful attention to information about warnings mentioned in the instructions and found on the warning signs on the lifting tools. If this information is not observed, severe personal injuries and equipment damage can arise.

### Responsibility

The instructions describe the authorized method to use the lifting tool.

The lifting tool may only be used by personnel with adequate technical training or corresponding professional experience and in consultation with the manufacturer.

If the instructions have not been followed, the manufacturer is not responsible for personal injuries or damage to equipment.

### Marking

Do not remove or make machine labels or other labels unreadable.

The lifting tool is marked with a CE mark, which means that it is designed, manufactured and described in accordance with EC Machinery Directive 2006/42/EC.

Warning decals and CE mark on lifting tool must be clearly visible. If a part provided with warning decals or CE mark is changed, a new warning decal and CE mark must be mounted in the same place. Defective decals and CE marks must be replaced immediately.



V1141218

## Figure 2

CE-marking

### Manufacturer

Company: Volvo Construction Equipment AB

Address: CE-46840, RLA 0301

Postal address: 631 85 Eskilstuna, Sweden

### Rebuilding

If the lifting tool is rebuilt or supplemented with other parts without permission by the manufacturer, the CE marking does not include this part. If such rebuilding or added parts changes the function of the lifting tool, the CE marking in its entirety is no longer valid. After rebuilding, it is important that the instructions are supplemented with the necessary illustrations, photos and texts.

### NOTE!

If not explicitly stated otherwise, always assume this instruction reference the use of two 9993807 Lifting tools.

### Intended usage

The lifting toll specified in this document is only intended for lifting torque converters with a maximum weight of 100 kg. Intended users are appointed and trained personnel, the lifting gear is not intended to be used by unauthorised or underage personnel.

To fulfil the requirements for intended use, the user must follow all instructions and maintenance directions written by the manufacturer.

### Technical data

Type designation: lifting tool for torque converter

Maximum load, lifting tool x 2: 100 kg (220 lb)

Mass, lifting tool x 2 with shackles and chain slings: 5 kg (11 lb)

Test factor for static testing (for lifting tools): 1.5

### Safety information

### Limits of use

The lifting tools may only be used for the intended purpose. All other use is forbidden.

Lifting hooks must be equipped with a self-locking hook.

Shackles should be used for connecting the tools.

Lifting sling and straps should be marked with lifting capacity.

All accessories for the lift must have sufficient lifting capacity.

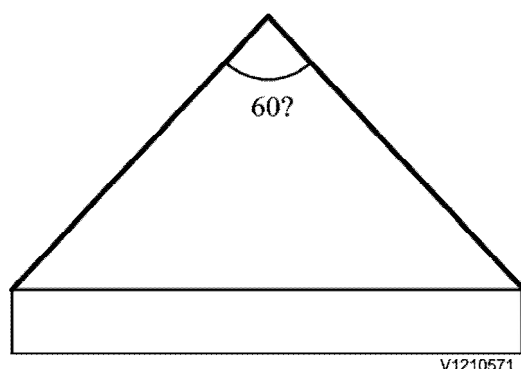

## Figure 3

Max lift-angle

Maximum lift angles must not exceed 60°.

### Handling

To meet the requirements for intended use, the user must observe all user and maintenance instructions prescribed by the manufacturer.

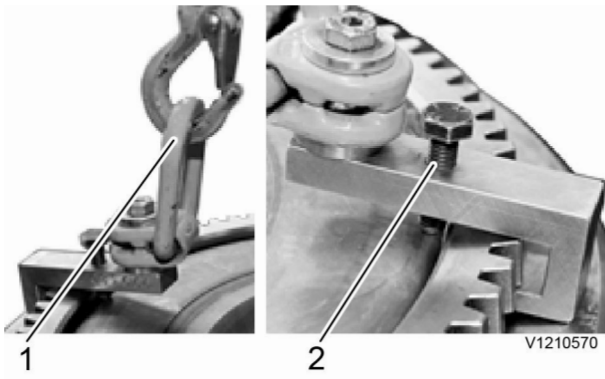

**Figure 4**

1. **Lifting equipment**  
 Use lifting sling with sufficient lifting capacity, 100 kg (220 lb).  
 Always use lifting hooks equipped with a self-locking hook.  
 Use shackles with sufficient lifting capacity, 100 kg (220 lb).
2. **Bolts**  
 Position the lifting tool under gear ring and tighten the bolts.  
 Tighten until the lifting tool is unable to move independently of the gear ring.

**Intended user**

The lifting device is intended to be used by trained personnel, it is not intended to be used by unauthorized or underage personnel.

**Conditions and preparatory measures**

Lifting tool with damaged parts must not be used.  
 Before lifting, check that the lifting tool does not have indications of cracks or deformations.

**Maintenance**

Maintenance must be performed by person with appropriate technical training or equivalent professional experience and in consultation with the manufacturer.

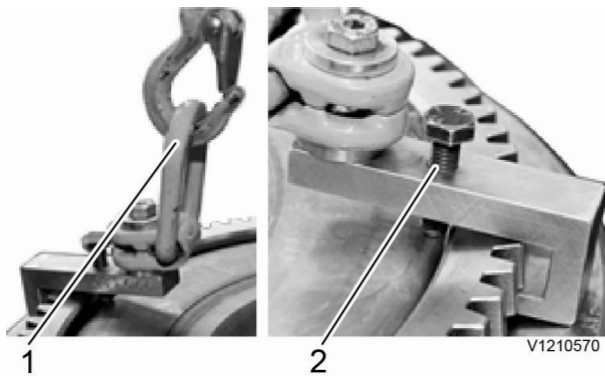

**Figure 5**

Detail/interval	Control/oversight
1 Shackles. Annual check.	Check that shackles does no have visible defects, cracks or deformations.
2 9993807 Lifting tool. Annual check.	Check that the lifting tool with threads and bolt does no have visible defects, cracks or deformations.

**General**

A defective lifting tool must be replaced.

**Workplace**

Protective shoes must be used.

The workplace should be kept free from equipment that can cause slipping or tripping risks.

The lifting tool is intended to be used in a workshop environment, outdoor usage is forbidden.

**Continuous supervision**

The lifting tool must be subjected to continuous supervision before use.

- Check for cracks.
- Check if the lifting tool is bent or deformed.
- Check that threaded screws and bolts are intact and do not have indications of breakage or deformation.

Document Title: <b>11668007 Lifting tool user instructions</b>	Function Group: <b>080</b>	Information Type: <b>Service Information</b>	Date: <b>4/13/2026</b>
Profile: <b>L250H Volvo</b>			

## 11668007 Lifting tool user instructions

Showing Selected Profile

Valid for serial numbers			
Model	Production site	Serial number start	Serial number stop
L250H Volvo			



V1210648

**Figure 1**  
11668007 lifting tool

**Instructions**

This instruction is a guide on how to use and maintain the lifting tool correctly. The instructions must be studied carefully by the personnel concerned before the lifting tool can be put into use.

The instructions must always be available to the personnel maintaining and using the lifting tool daily.

**It is also important to:**

- Keep the instructions and other applicable documents during the entire lifetime of the lifting tool.
- Pass the instructions to other owners or users of the lifting tool.
- Update the instructions with additions or changes made by the manufacturer.

Pay careful attention to information about warnings mentioned in the instructions and found on the warning signs on the lifting tools. If this information is not observed, severe personal injuries and equipment damage can arise.

**Responsibility**

The instructions describe the authorized method to use the lifting tool.

The lifting tool may only be used by personnel with adequate technical training or corresponding professional experience and in consultation with the manufacturer.

If the instructions have not been followed, the manufacturer is not responsible for personal injuries or damage to

equipment.

### Marking

Do not remove or make machine labels or other labels unreadable.

The lifting tool is marked with a CE mark, which means that it is designed, manufactured and described in accordance with EC Machinery Directive 2006/42/EC.

Warning decals and CE mark on lifting tool must be clearly visible. If a part provided with warning decals or CE mark is changed, a new warning decal and CE mark must be mounted in the same place. Defective decals and CE marks must be replaced immediately.

### Manufacturer

Company: BM Lindahl AB

Address: Älmedal 6

Postal address: 364 33 Åseda, Sweden

### Rebuilding

If the lifting tool is rebuilt or supplemented with other parts without permission by the manufacturer, the CE marking does not include this part. If such rebuilding or added parts changes the function of the lifting tool, the CE marking in its entirety is no longer valid. After rebuilding, it is important that the instructions are supplemented with the necessary illustrations, photos and texts.

### Intended usage

11668007 Lifting tool consists of stand, lifting jack, extensions and locking pins.

Intended users are appointed and trained personnel, the lifting tool is not intended to be used by unauthorized or underage personnel.

To fulfil the requirements for intended use, the user must follow all instructions and maintenance directions written by the manufacturer.

The lifting tool is only intended for lifting Volvo Wheel Loaders and Volvo Articulated Haulers. Maximum load: 15 000 kg (33 070 lb).

### Technical data

Type designation: lifting tool

Maximum load: 15 000 kg (33 070 lb), with two 11668007 lifting tools: 30 000 kg (66 140 lbs)

Mass: 78 kg (172 lb)

Test factor for static testing: For lifting tools and manually operated machines: 1.5. For other machines: 1.25

Height: 500–800 mm (19.7–31.5 in), with extensions: 600–900 mm (23.6–35.4 in)

### Safety information

#### Limits of use

The lifting tools may only be used for the intended purpose. All other use is forbidden.

For Volvo Wheel Loaders, the lifting tool is only intended to lift the rear axle.



V1071600

Always secured loads with safety pins. To stay under raised load without locking pins, is associated with life danger.



V1071600

To prevent breakage and sliding, the lifting tool must always be used with a vertical load.

To prevent oblique loads, always use two 11668007 lifting tools.

#### Handling

To meet the requirements for intended use, the user must observe all user and maintenance instructions prescribed by the manufacturer.

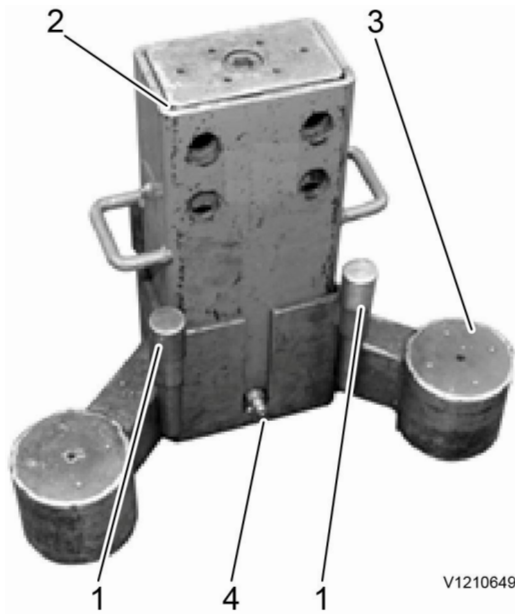

**Figure 2**

Pre use check

1. **Safety pins**  
Make sure that safety pins are supplied along with the lifting tool.  
Check that the safety pins are intact and do not have indications of breakage or deformation.
2. **Inner and outer lifting beam**  
Check that the beam with pin holes is intact and do not have indications of breakage or deformation.
3. **Support legs**  
The lifting tool has three support legs.  
Check that the stand is intact and does not have indications of breakage or deformation.
4. **Connection nipple**  
Connection nipple for pneumatic pump.

#### **Pneumatic pump**

Check that pneumatic pump with hose kit and couplings does not have indications of breakage or deformation. Always replace defective units.

#### **Intended user**

The lifting device is intended to be use by trained personnel, it is not intended to be used by unauthorized or underage personnel.

#### **Conditions and preparatory measures**

Lifting tool with damaged parts must not be used.



V1071600

Make sure that there are no people in the vicinity who may be at risk when operating this lifting tool.

#### **Lifting**



V1071600

Never stay under raised load with the safety pins disconnected.

1. **Steering linkage lock**  
Lock steering linkage with steering linkage lock.  
If an articulated hauler is being lifted, place body support.  
Connect stops.
2. **Assemble**  
Place the lifting jack into the stand.  
Make sure the nipple fits in the groove.
3. **Place the lifting tool**

Place the lifting tool under wheel axle lifting point.

If needed, connect extensions.

Connect pneumatic pump to the respective nipple on the lifting tools.

To ensure a parallel lift, lower the lifting tools to their lower end point.

Start the pneumatic pump (pumps) and lift to the desired level.

4. **Safety pins**

Connect all safety pins. Make sure that all safety pins are fully inserted.

Lower until the load rests on the safety pins.



**Figure 3**

### Lowering

1. **Steering linkage lock**

Remove steering linkage lock.

Remove stops.

2. **Remove safety pins**

Lift the load with the lifting tools to release the safety pins.

Remove all safety pins and place the safety pins at their designed holders on the lifting tools.

3. **Lower the load**

Lower the load.

Lower the lifting tools to their lower end point.

Make sure that the lifting tools are lowered parallel to avoid uneven weight distribution.

4. **Remove pump and lifting tool**

Disconnect the pneumatic pump (pumps) from the nipples on the lifting tools.

Remove the lifting tool and place it at the designated location.

### Maintenance

Maintenance must be performed by person with appropriate technical training or equivalent professional experience and in consultation with the manufacturer.

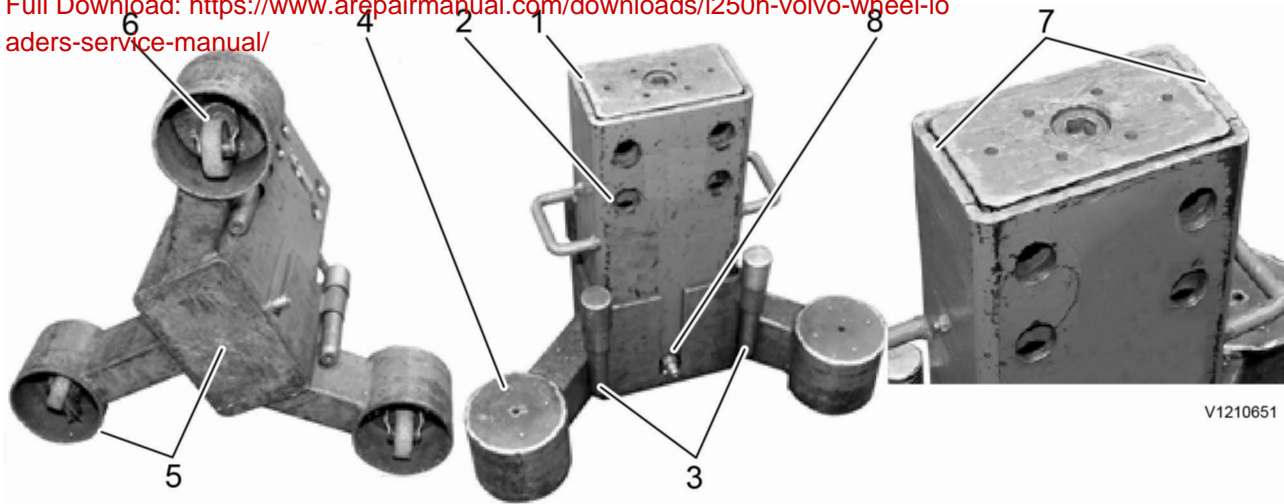

V1210651

Figure 4

Detail/interval	Control/oversight
<b>1. Inner and outer beam</b> Before use.	Check that beams are intact and does not have indications of breakage or deformation.
<b>2. Pin holes, inner and outer beam</b> Before use.	Check that all holes in beams are intact and does not have indications of breakage or deformation.
<b>3. Pins</b> Before use.	Check that all pins are intact and does not have indications of breakage or deformation. Before lifting, make sure that no pins are missing.
<b>4. Support legs</b> Before use.	Check that the support legs are intact and does not have indications of breakage or deformation.
<b>5. Supporting surfaces</b> Monthly check.	Check that all supporting areas are intact and does not have indications of breakage or deformation.
<b>6. Castor</b> As needed.	Replaced as needed.
<b>7. Friction plate</b> Annual check or as needed.	Lift the inner beam to its upper end point. Grease the friction plates and lower the beam to its lower end point to disperse the grease.
<b>8. Quick coupling</b> Before use.	Check that the quick coupling is clean. Clean dirty quick coupling with cloth. Protect quick coupling with plastic cover.

**General**

A defective lifting tool must be replaced.

**Workplace**

Protective shoes must be used.

The workplace should be kept free from equipment that can cause slipping or tripping risks.

The lifting tool is intended to be used in a workshop environment, outdoor usage is forbidden.

The lifting tool is intended to be used on a level and stable surface.

Leaked or spilled hydraulic oil should be taken care of immediately with an absorbent to prevent slipping. The supplier/ manufacturers product sheet regarding safe handling of hydraulic oil must be followed.

**Continuous supervision**

The lifting tool must be subjected to continuous supervision before use.

- Check for cracks.
- Check if the lifting tool is bent or deformed.
- Make sure that quick couplings are clean.

Sample manual. Download All 3502 pages at:

<https://www.arpairmanual.com/downloads/l250h-volvo-wheel-loaders-service-manual/>