



| | | | |
|---|-------------------------------|---|---------------------------|
| Document Title: Volvo standard tightening torques | Function Group: 030 | Information Type: Service Information | Date: 4/13/2026 |
| Profile: L250G Volvo | | | |

Volvo standard tightening torques

Showing Selected Profile

| Valid for serial numbers | | | |
|--------------------------|-----------------|---------------------|--------------------|
| Model | Production site | Serial number start | Serial number stop |
| L250G Volvo | | | |

The tightening torques in the following tables apply to bolts and nuts with tensile strength. The tables should be used as a general instruction for tightening bolts and nuts without specified values. The charts contains values for course thread bolts and nuts.

Torque values should be increased with $\approx 10\%$, for flange bolts.

All standard torques for bolts are without surface treatment.

The standard torque for bolts lubricated with oil should be reduced with 20% of the given value.

Standard tightening torque charts

| Bolt size Metric Coarse Threads | Tensile strength 8.8 | | Tensile strength 10.9 | |
|---------------------------------------|----------------------|----------|-----------------------|----------|
| | (Nm) | (lbf ft) | (Nm) | (lbf ft) |
| M5 | 6 | 4 | 8 | 6 |
| M6 | 10 | 7 | 14 | 11 |
| M8 | 25 | 18 | 35 | 26 |
| M10 | 50 | 37 | 70 | 52 |
| M12 | 87 | 64 | 122 | 90 |
| M14 | 139 | 103 | 195 | 144 |
| M16 | 213 | 157 | 299 | 220 |
| M18 | 293 | 216 | 413 | 305 |
| M20 | 416 | 307 | 585 | 432 |
| M24 | 719 | 530 | 1010 | 745 |
| M27 | 1060 | 782 | 1490 | 1100 |
| M30 | 1140 | 840 | 2025 | 1493 |
| M36 | 2500 | 1844 | 3600 | 2653 |

| Bolt size Inch SAE Coarse Threads | Tensile strength 5 | | Tensile strength 8 | |
|---|--------------------|--------|--------------------|--------|
| | (lbf ft) | (Nm) | (lbf ft) | (Nm) |
| 1/4 | 10 | 13,6 | 14 | 19 |
| 5/16 | 21 | 28,5 | 29 | 39,3 |
| 3/8 | 37 | 50,2 | 52 | 70 |
| 7/16 | 59 | 80 | 84 | 114 |
| 1/2 | 90 | 122 | 128 | 174 |
| 9/16 | 130 | 176 | 184 | 250 |
| 5/8 | 200 | 271 | 284 | 388 |
| 3/4 | 270 | 365 | 384 | 520 |
| 7/8 | 350 | 472 | 500 | 672 |
| 1 | 430 | 580 | 600 | 812 |
| 1 1/8 | 550 | 744 | 770 | 1048 |
| 1 1/4 | 670 | 908 | 940 | 1272 |
| 1 3/8 | 800 | 1080 | 1120 | 1504 |
| 1 1/2 | 950 | 1290 | 1340 | 1772 |
| 1 3/4 | 1100 | 1490 | 1550 | 2096 |
| 2 | 1300 | 1780 | 1850 | 2560 |
| 2 1/4 | 1550 | 2100 | 2200 | 3072 |
| 2 3/4 | 1800 | 2440 | 2550 | 3472 |
| 3 | 2050 | 2790 | 2900 | 3968 |
| 3 1/2 | 2400 | 3260 | 3400 | 4608 |
| 4 | 2700 | 3650 | 3800 | 5168 |
| 4 1/2 | 3000 | 4060 | 4200 | 5744 |
| 5 | 3300 | 4470 | 4600 | 6336 |
| 5 1/2 | 3600 | 4890 | 5000 | 6944 |
| 6 | 3900 | 5310 | 5400 | 7568 |
| 6 1/2 | 4200 | 5740 | 5800 | 8208 |
| 7 | 4500 | 6170 | 6200 | 8864 |
| 7 1/2 | 4800 | 6610 | 6600 | 9536 |
| 8 | 5100 | 7050 | 7000 | 10224 |
| 8 1/2 | 5400 | 7500 | 7400 | 10928 |
| 9 | 5700 | 7950 | 7800 | 11648 |
| 9 1/2 | 6000 | 8410 | 8200 | 12384 |
| 10 | 6300 | 8870 | 8600 | 13136 |
| 10 1/2 | 6600 | 9340 | 9000 | 13904 |
| 11 | 6900 | 9810 | 9400 | 14688 |
| 11 1/2 | 7200 | 10290 | 9800 | 15488 |
| 12 | 7500 | 10770 | 10200 | 16304 |
| 12 1/2 | 7800 | 11260 | 10600 | 17136 |
| 13 | 8100 | 11750 | 11000 | 17984 |
| 13 1/2 | 8400 | 12250 | 11400 | 18848 |
| 14 | 8700 | 12750 | 11800 | 19728 |
| 14 1/2 | 9000 | 13260 | 12200 | 20632 |
| 15 | 9300 | 13770 | 12600 | 21552 |
| 15 1/2 | 9600 | 14280 | 13000 | 22488 |
| 16 | 9900 | 14790 | 13400 | 23440 |
| 16 1/2 | 10200 | 15310 | 13800 | 24408 |
| 17 | 10500 | 15830 | 14200 | 25392 |
| 17 1/2 | 10800 | 16350 | 14600 | 26392 |
| 18 | 11100 | 16870 | 15000 | 27408 |
| 18 1/2 | 11400 | 17400 | 15400 | 28440 |
| 19 | 11700 | 17930 | 15800 | 29488 |
| 19 1/2 | 12000 | 18460 | 16200 | 30552 |
| 20 | 12300 | 19000 | 16600 | 31632 |
| 20 1/2 | 12600 | 19540 | 17000 | 32728 |
| 21 | 12900 | 20080 | 17400 | 33840 |
| 21 1/2 | 13200 | 20630 | 17800 | 34968 |
| 22 | 13500 | 21170 | 18200 | 36112 |
| 22 1/2 | 13800 | 21720 | 18600 | 37272 |
| 23 | 14100 | 22270 | 19000 | 38448 |
| 23 1/2 | 14400 | 22830 | 19400 | 39640 |
| 24 | 14700 | 23390 | 19800 | 40848 |
| 24 1/2 | 15000 | 23950 | 20200 | 42072 |
| 25 | 15300 | 24510 | 20600 | 43312 |
| 25 1/2 | 15600 | 25080 | 21000 | 44568 |
| 26 | 15900 | 25650 | 21400 | 45840 |
| 26 1/2 | 16200 | 26220 | 21800 | 47128 |
| 27 | 16500 | 26800 | 22200 | 48432 |
| 27 1/2 | 16800 | 27380 | 22600 | 49752 |
| 28 | 17100 | 27960 | 23000 | 51088 |
| 28 1/2 | 17400 | 28550 | 23400 | 52440 |
| 29 | 17700 | 29140 | 23800 | 53808 |
| 29 1/2 | 18000 | 29740 | 24200 | 55192 |
| 30 | 18300 | 30340 | 24600 | 56592 |
| 30 1/2 | 18600 | 30940 | 25000 | 58008 |
| 31 | 18900 | 31540 | 25400 | 59440 |
| 31 1/2 | 19200 | 32150 | 25800 | 60888 |
| 32 | 19500 | 32750 | 26200 | 62352 |
| 32 1/2 | 19800 | 33360 | 26600 | 63832 |
| 33 | 20100 | 33970 | 27000 | 65328 |
| 33 1/2 | 20400 | 34580 | 27400 | 66840 |
| 34 | 20700 | 35190 | 27800 | 68368 |
| 34 1/2 | 21000 | 35800 | 28200 | 69912 |
| 35 | 21300 | 36410 | 28600 | 71472 |
| 35 1/2 | 21600 | 37020 | 29000 | 73048 |
| 36 | 21900 | 37630 | 29400 | 74640 |
| 36 1/2 | 22200 | 38240 | 29800 | 76248 |
| 37 | 22500 | 38850 | 30200 | 77872 |
| 37 1/2 | 22800 | 39460 | 30600 | 79512 |
| 38 | 23100 | 40070 | 31000 | 81168 |
| 38 1/2 | 23400 | 40680 | 31400 | 82840 |
| 39 | 23700 | 41290 | 31800 | 84528 |
| 39 1/2 | 24000 | 41900 | 32200 | 86232 |
| 40 | 24300 | 42510 | 32600 | 87952 |
| 40 1/2 | 24600 | 43120 | 33000 | 89688 |
| 41 | 24900 | 43730 | 33400 | 91440 |
| 41 1/2 | 25200 | 44340 | 33800 | 93208 |
| 42 | 25500 | 44950 | 34200 | 94992 |
| 42 1/2 | 25800 | 45560 | 34600 | 96792 |
| 43 | 26100 | 46170 | 35000 | 98608 |
| 43 1/2 | 26400 | 46780 | 35400 | 100440 |
| 44 | 26700 | 47390 | 35800 | 102288 |
| 44 1/2 | 27000 | 48000 | 36200 | 104152 |
| 45 | 27300 | 48610 | 36600 | 106032 |
| 45 1/2 | 27600 | 49220 | 37000 | 107928 |
| 46 | 27900 | 49830 | 37400 | 109840 |
| 46 1/2 | 28200 | 50440 | 37800 | 111768 |
| 47 | 28500 | 51050 | 38200 | 113712 |
| 47 1/2 | 28800 | 51660 | 38600 | 115672 |
| 48 | 29100 | 52270 | 39000 | 117648 |
| 48 1/2 | 29400 | 52880 | 39400 | 119640 |
| 49 | 29700 | 53490 | 39800 | 121648 |
| 49 1/2 | 30000 | 54100 | 40200 | 123672 |
| 50 | 30300 | 54710 | 40600 | 125712 |
| 50 1/2 | 30600 | 55320 | 41000 | 127768 |
| 51 | 30900 | 55930 | 41400 | 129840 |
| 51 1/2 | 31200 | 56540 | 41800 | 131928 |
| 52 | 31500 | 57150 | 42200 | 134032 |
| 52 1/2 | 31800 | 57760 | 42600 | 136152 |
| 53 | 32100 | 58370 | 43000 | 138288 |
| 53 1/2 | 32400 | 58980 | 43400 | 140440 |
| 54 | 32700 | 59590 | 43800 | 142608 |
| 54 1/2 | 33000 | 60200 | 44200 | 144792 |
| 55 | 33300 | 60810 | 44600 | 146992 |
| 55 1/2 | 33600 | 61420 | 45000 | 149208 |
| 56 | 33900 | 62030 | 45400 | 151440 |
| 56 1/2 | 34200 | 62640 | 45800 | 153688 |
| 57 | 34500 | 63250 | 46200 | 155952 |
| 57 1/2 | 34800 | 63860 | 46600 | 158232 |
| 58 | 35100 | 64470 | 47000 | 160528 |
| 58 1/2 | 35400 | 65080 | 47400 | 162840 |
| 59 | 35700 | 65690 | 47800 | 165168 |
| 59 1/2 | 36000 | 66300 | 48200 | 167512 |
| 60 | 36300 | 66910 | 48600 | 169872 |
| 60 1/2 | 36600 | 67520 | 49000 | 172248 |
| 61 | 36900 | 68130 | 49400 | 174640 |
| 61 1/2 | 37200 | 68740 | 49800 | 177056 |
| 62 | 37500 | 69350 | 50200 | 179488 |
| 62 1/2 | 37800 | 69960 | 50600 | 181936 |
| 63 | 38100 | 70570 | 51000 | 184400 |
| 63 1/2 | 38400 | 71180 | 51400 | 186880 |
| 64 | 38700 | 71790 | 51800 | 189376 |
| 64 1/2 | 39000 | 72400 | 52200 | 191888 |
| 65 | 39300 | 73010 | 52600 | 194416 |
| 65 1/2 | 39600 | 73620 | 53000 | 196960 |
| 66 | 39900 | 74230 | 53400 | 199520 |
| 66 1/2 | 40200 | 74840 | 53800 | 202096 |
| 67 | 40500 | 75450 | 54200 | 204688 |
| 67 1/2 | 40800 | 76060 | 54600 | 207296 |
| 68 | 41100 | 76670 | 55000 | 209920 |
| 68 1/2 | 41400 | 77280 | 55400 | 212560 |
| 69 | 41700 | 77890 | 55800 | 215216 |
| 69 1/2 | 42000 | 78500 | 56200 | 217888 |
| 70 | 42300 | 79110 | 56600 | 220576 |
| 70 1/2 | 42600 | 79720 | 57000 | 223280 |
| 71 | 42900 | 80330 | 57400 | 225992 |
| 71 1/2 | 43200 | 80940 | 57800 | 228720 |
| 72 | 43500 | 81550 | 58200 | 231464 |
| 72 1/2 | 43800 | 82160 | 58600 | 234224 |
| 73 | 44100 | 82770 | 59000 | 236992 |
| 73 1/2 | 44400 | 83380 | 59400 | 239776 |
| 74 | 44700 | 83990 | 59800 | 242576 |
| 74 1/2 | 45000 | 84600 | 60200 | 245392 |
| 75 | 45300 | 85210 | 60600 | 248224 |
| 75 1/2 | 45600 | 85820 | 61000 | 251072 |
| 76 | 45900 | 86430 | 61400 | 253936 |
| 76 1/2 | 46200 | 87040 | 61800 | 256816 |
| 77 | 46500 | 87650 | 62200 | 259712 |
| 77 1/2 | 46800 | 88260 | 62600 | 262624 |
| 78 | 47100 | 88870 | 63000 | 265552 |
| 78 1/2 | 47400 | 89480 | 63400 | 268496 |
| 79 | 47700 | 90090 | 63800 | 271456 |
| 79 1/2 | 48000 | 90700 | 64200 | 274432 |
| 80 | 48300 | 91310 | 64600 | 277424 |
| 80 1/2 | 48600 | 91920 | 65000 | 280432 |
| 81 | 48900 | 92530 | 65400 | 283456 |
| 81 1/2 | 49200 | 93140 | 65800 | 286496 |
| 82 | 49500 | 93750 | 66200 | 289552 |
| 82 1/2 | 49800 | 94360 | 66600 | 292624 |
| 83 | 50100 | 94970 | 67000 | 295712 |
| 83 1/2 | 50400 | 95580 | 67400 | 298816 |
| 84 | 50700 | 96190 | 67800 | 301936 |
| 84 1/2 | 51000 | 96800 | 68200 | 305072 |
| 85 | 51300 | 97410 | 68600 | 308224 |
| 85 1/2 | 51600 | 98020 | 69000 | 311392 |
| 86 | 51900 | 98630 | 69400 | 314576 |
| 86 1/2 | 52200 | 99240 | 69800 | 317776 |
| 87 | 52500 | 99850 | 70200 | 320992 |
| 87 1/2 | 52800 | 100460 | 70600 | 324224 |
| 88 | 53100 | 101070 | 71000 | 327472 |
| 88 1/2 | 53400 | 101680 | 71400 | 330736 |
| 89 | 53700 | 102290 | 71800 | 334016 |
| 89 1/2 | 54000 | 102900 | 72200 | 337312 |
| 90 | 54300 | 103510 | 72600 | 340624 |
| 90 1/2 | 54600 | 104120 | 73000 | 343952 |
| 91 | 54900 | 104730 | 73400 | 347296 |
| 91 1/2 | 55200 | 105340 | 73800 | 350656 |
| 92 | 55500 | 105950 | 74200 | 354032 |
| 92 1/2 | 55800 | 106560 | 74600 | 357424 |
| 93 | 56100 | 107170 | 75000 | 360832 |
| | | | | |

Product: L250G Volvo Wheel Loaders Service Manual

Full Download: <https://www.arepairmanual.com/downloads/l250g-volvo-wheel-loaders-service-manual/>

| | | | | |
|-------|------|------|------|------|
| 3/4 | 320 | 434 | 451 | 612 |
| 7/8 | 515 | 700 | 728 | 988 |
| 1 | 775 | 1052 | 1091 | 1480 |
| 1 1/8 | 953 | 1290 | 1545 | 2100 |
| 1 1/4 | 1344 | 1823 | 2180 | 2960 |
| 1 3/8 | 1600 | 2170 | 2650 | 3600 |
| 1 1/2 | 2000 | 2714 | 3200 | 4340 |

Sample manual. Download All 2716 pages at:

<https://www.arepairmanual.com/downloads/l250g-volvo-wheel-loaders-service-manual/>

| | | | |
|--|-------------------------------|---|---------------------------|
| Document Title: Tightening torque, cylinder head | Function Group: 030 | Information Type: Service Information | Date: 4/13/2026 |
| Profile: L250G Volvo | | | |

Tightening torque, cylinder head

Showing Selected Profile

| Valid for serial numbers | | | |
|--------------------------|-----------------|---------------------|--------------------|
| Model | Production site | Serial number start | Serial number stop |
| L250G Volvo | | | |

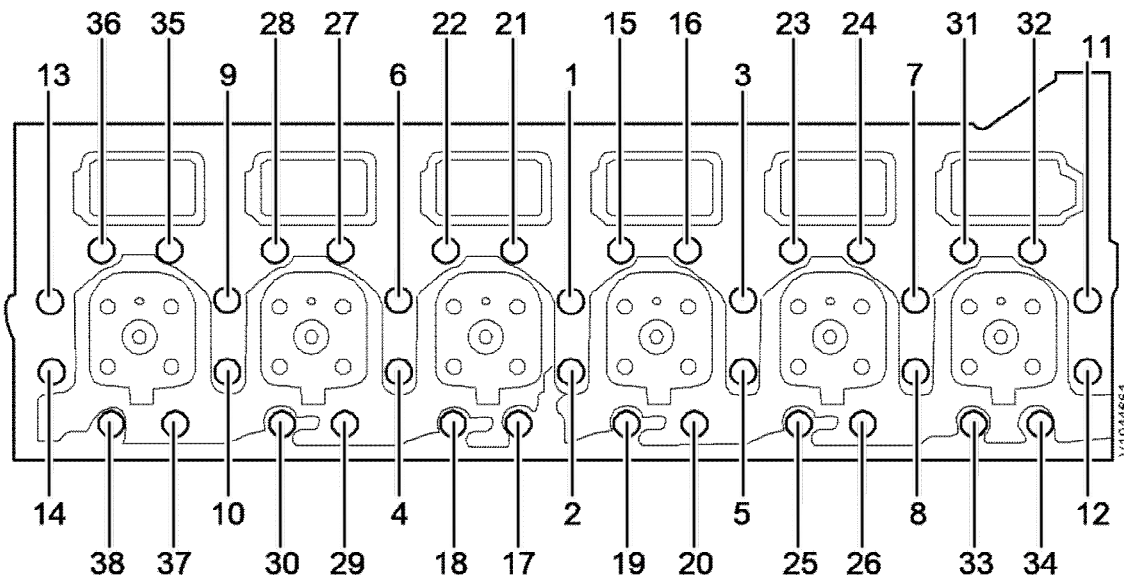

Figure 1
Cylinder head, D13

NOTE!

Tighten the bolts in the sequence shown in the figure.

| | |
|--------|--------------------------------|
| Step 1 | 100±5Nm(74±3.7 lbf ft) |
| Step 2 | 120±5° Angle-tightening |
| Step 3 | 90±5° Angle-tightening |

| | | | | |
|--|--------------------|-----------------|---|---------------------------|
| Document Title: Lubrication specifications | system, 030 | Function Group: | Information Type: Service Information | Date: 4/13/2026 |
| Profile: L250G Volvo | | | | |

Lubrication system, specifications

Showing Selected Profile

| Valid for serial numbers | | | |
|--------------------------|-----------------|---------------------|--------------------|
| Model | Production site | Serial number start | Serial number stop |
| L250G Volvo | | | |

Oil pressure

| | |
|-----------|-------------------------|
| Low idle | Min. 220 kPa (31.9 PSI) |
| High idle | 350 kPa (50.7 PSI) |

Oil temperature

| | |
|--|-----------------------------|
| Operating temperature, coolant temperature 75–95 °C (167–203 °F) | 90–110 °C (194–230 °F) |
| Heavy load | Up to 125 °C (up to 257 °F) |

Oil filter

| | |
|------------------|---|
| Full flow filter | 2 |
| Bypass filter | 1 |

Oil consumption

| | |
|---|-------------|
| Oil consumption in percentage of fuel consumption | Max. 0.45 % |
|---|-------------|

NOTE!

A new or fully overhauled engine often uses more oil than an engine already in operation. It is only possible to determine the correct oil consumption, of the engine, after 1000-1500 operating hours.

| | | | |
|--|-------------------------------|---|---------------------------|
| Document Title: Oil cooler, tightening torques | Function Group: 030 | Information Type: Service Information | Date: 4/13/2026 |
| Profile: L250G Volvo | | | |

Oil cooler, tightening torques

Showing Selected Profile

| Valid for serial numbers | | | |
|--------------------------|-----------------|---------------------|--------------------|
| Model | Production site | Serial number start | Serial number stop |
| L250G Volvo | | | |

Oil cooler

| Oil cooler, attaching bolts: | Nm | lbf ft |
|------------------------------|-------|--------|
| Tighten the bolts crosswise | 27 ±4 | 20±3 |

Oil cooler, cover

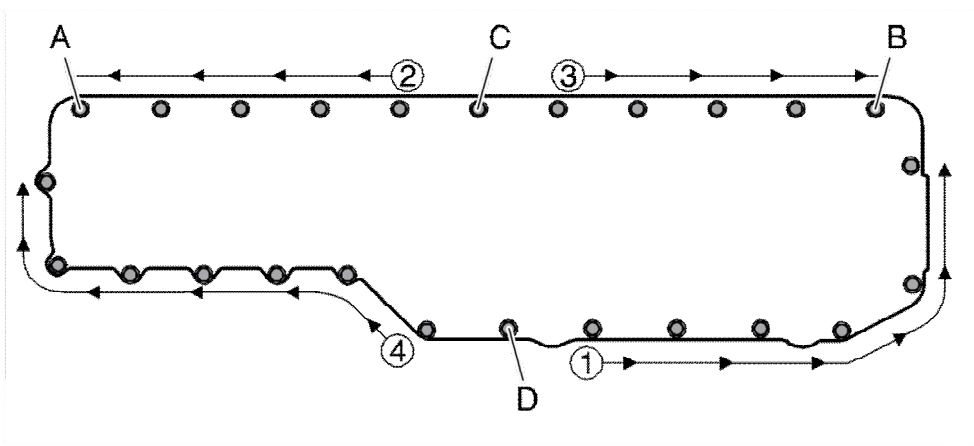

Figure 1

| Oil cooler, cover: | Nm | lbf ft |
|--|-------|--------|
| Install the cover on the engine block and insert bolt A in the oval hole | | |
| Press the cover against the coolant pump housing and install bolt B | | |
| Install bolts C and D and tighten | 24 ±4 | 18±3 |
| Tighten the cover's bolts in order, see diagram | 24 ±4 | 18±3 |
| Finish by tightening bolts C and D again | 24 ±4 | 18±3 |

| | | | |
|---|-------------------------------|---|---------------------------|
| Document Title: Tightening torques, unit injector | Function Group: 030 | Information Type: Service Information | Date: 4/13/2026 |
| Profile: L250G Volvo | | | |

[Go back to Index Page](#)

Tightening torques, unit injector

Showing Selected Profile

| Valid for option/configuration | | | |
|--------------------------------|------------|--------|------------------------|
| Model | Option no. | Option | Configuration |
| L250G Volvo | 85420 | Engine | D13H US Tier 4 interim |
| L250G Volvo | 85421 | Engine | D13H EU Stage IIIB |

NOTE!

The stated torques apply to lubricated bolts.

Steel sleeve

| Fastener yoke, unit injectors | |
|---|-----------------------------------|
| Step 1 | 20 Nm +5/-0 (14.8 +3.7/-0 lbf ft) |
| Step 2: Angle-tightening | 180° ±5° |
| Step 3: Loose the yoke's bolt until the torque is | 10–15 Nm (7.4–11 lbf ft) |
| Step 4 | 20 Nm +5/-0 (14.8 +3.7/-0 lbf ft) |
| Step 5: Angle-tightening | 90° ±5° |

| Fastener yoke, unit injectors (new steel sleeve or new cylinder head) | |
|---|-----------------------------------|
| Step 1 | 30 Nm +5/-0 (22.1 +3.7/-0 lbf ft) |
| Step 2: Angle-tightening | 150° ±5° |
| Step 3: Loose the yoke's bolt until the torque is | 10–15 Nm (7.4–11 lbf ft) |
| Step 4 | 30 Nm +5/-0 (22.1 +3.7/-0 lbf ft) |
| Step 5: Angle-tightening | 75° ±5° |

NOTE!

When replacing/dismantling an injector with washer, a new washer must always be used. Never reuse the washer.

| Unit injectors, tightening torques | |
|------------------------------------|--|
| Unit injectors, preload | Tighten the adjusting screw to zero clearance against the camshaft, then turn it 240° ±20° |
| Lock nut for adjusting screw | 52±2 Nm (38.4±1.5 lbf ft) |
| Fuel pump | 24 ±2 Nm (17.7 ±1.5 lbf ft) |

| | | | |
|---|-------------------------------|---|---------------------------|
| Document Title: Tightening torques, unit injector | Function Group: 030 | Information Type: Service Information | Date: 4/13/2026 |
| Profile: L250G Volvo | | | |

[Go back to Index Page](#)

Tightening torques, unit injector

Showing Selected Profile

| Valid for option/configuration | | | |
|--------------------------------|------------|--------|---------------|
| Model | Option no. | Option | Configuration |
| L250G Volvo | 85424 | Engine | D13F Stage II |

NOTE!

The stated torques apply to lubricated bolts.

Copper sleeve

| Fastener yoke, unit injectors | |
|---|-----------------------------------|
| Step 1 | 20 Nm +5/-0 (14.8 +3.7/-0 lbf ft) |
| Step 2: Angle-tightening | 180° ±5° |
| Step 3: Loose the yoke's bolt until the torque is | 10–15 Nm (7.4–11 lbf ft) |
| Step 4 | 20 Nm +5/-0 (14.8 +3.7/-0 lbf ft) |
| Step 5: Angle-tightening | 90° ±5° |

| Fastener yoke, unit injectors (new steel sleeve or new cylinder head) | |
|---|-----------------------------------|
| Step 1 | 20 Nm +5/-0 (14.8 +3.7/-0 lbf ft) |
| Step 2: Angle-tightening | 180° ±5° |
| Step 3: Loose the yoke's bolt until the torque is | 10–15 Nm (7.4–11 lbf ft) |
| Step 4 | 25 Nm +5/-0 (18.4 +3.7/-0 lbf ft) |
| Step 5: Angle-tightening | 90° ±5° |

NOTE!

When replacing/dismantling an injector with washer, a new washer must always be used. Never reuse the washer.

| Unit injectors, tightening torques | |
|------------------------------------|--|
| Unit injectors, preload | Tighten the adjusting screw to zero clearance against the camshaft, then turn it 240° ±20° |
| Lock nut for adjusting screw | 52 ±4 Nm (38,4 ±2.95 lbf ft) |
| Fuel pump | 24 ±2 Nm (17.7 ±1.5 lbf ft) |

| | | | |
|---|-------------------------------|---|---------------------------|
| Document Title: Exhaust aftertreatment system, specifications | Function Group: 030 | Information Type: Service Information | Date: 4/13/2026 |
| Profile: L250G Volvo | | | |

Exhaust aftertreatment system, specifications

Showing Selected Profile

| Valid for option/configuration | | | |
|--------------------------------|------------|--------|------------------------|
| Model | Option no. | Option | Configuration |
| L250G Volvo | 85420 | Engine | D13H US Tier 4 interim |
| L250G Volvo | 85421 | Engine | D13H EU Stage IIIB |

| Valid for serial numbers | | | |
|--------------------------|-----------------|---------------------|--------------------|
| Model | Production site | Serial number start | Serial number stop |
| L250G Volvo | Arvika | 3001 | 3251 |
| L250G Volvo | Arvika | 3252 | 9999 |

Differential pressure DPF

| | |
|---|--------------------|
| Maximum permitted differential pressure before service regeneration | 15.2 kPa (2.2 psi) |
| Maximum permitted differential pressure after service regeneration | 9 kPa (1.3 psi) |

Fuel pressure

| | |
|------------------|--------------------------|
| Atomization unit | 690 ±35 kPa (100 ±5 psi) |
|------------------|--------------------------|

NOTICE

Risk of machine damage.

Adjusting the pressure could damage the regulator.

Do not attempt to adjust the pressure.

Air pressure

| | |
|--|-------------------------|
| Air pressure at the nozzle's pressure sensor | 414 ±35 kPa (60 ±5 psi) |
|--|-------------------------|

NOTICE

Risk of machine damage.

Adjusting the pressure could damage the regulator.

Do not attempt to adjust the pressure.

Exhaust aftertreatment system fuel flow, checking

| | |
|---|-----|
| Maximum permitted difference between the metered fuel and the VCADS PRO result: | 20% |
|---|-----|

Unit converter for fuel (kg to litres)

| | |
|---|--------------|
| x = fuel in kg y = volume in litres Fuel density = 0.82 kg/dm ³ at 20 °C | $x/0.82 = y$ |
|---|--------------|

US units

1 l = 0.264 US gallon

1 kg = 2.204 lb

| VCADS value (g) | Litres (l) | US gallon |
|------------------------|-------------------|------------------|
| 170 | 0.207 | 0.055 |
| 180 | 0.219 | 0.058 |
| 190 | 0.231 | 0.061 |
| 200 | 0.243 | 0.064 |
| 210 | 0.256 | 0.068 |
| 220 | 0.268 | 0.071 |
| 230 | 0.280 | 0.074 |
| 240 | 0.292 | 0.077 |
| 250 | 0.304 | 0.080 |
| 260 | 0.317 | 0.084 |
| 270 | 0.329 | 0.087 |
| 280 | 0.341 | 0.090 |
| 290 | 0.354 | 0.094 |
| 300 | 0.365 | 0.096 |
| 310 | 0.378 | 0.100 |
| 320 | 0.390 | 0.103 |

| | | | |
|---|-------------------------------|---|---------------------------|
| Document Title: Compressed-air system, specifications | Function Group: 030 | Information Type: Service Information | Date: 4/13/2026 |
| Profile: L250G Volvo | | | |

Compressed-air system, specifications

Showing Selected Profile

| Valid for option/configuration | | | |
|---------------------------------------|-------------------|---------------|------------------------|
| Model | Option no. | Option | Configuration |
| L250G Volvo | 85420 | Engine | D13H US Tier 4 interim |
| L250G Volvo | 85421 | Engine | D13H EU Stage IIIB |

| Valid for serial numbers | | | |
|---------------------------------|------------------------|----------------------------|---------------------------|
| Model | Production site | Serial number start | Serial number stop |
| L250G Volvo | Arvika | 3001 | 3251 |
| L250G Volvo | Arvika | 3252 | 9999 |

| Compressed air regulator | |
|---------------------------------|---|
| Cut-in pressure | 810 – 730 kPa (8.1 – 7.3 bar) (117 – 106 psi) |
| Cut-out pressure | 830 – 870 kPa (8.3 – 8.7 bar) (120 – 126 psi) |

| | | | |
|--|-------------------------------|---|---------------------------|
| Document Title: Turbocharger, specifications | Function Group: 030 | Information Type: Service Information | Date: 4/13/2026 |
| Profile: L250G Volvo | | | |

[Go back to Index Page](#)

Turbocharger, specifications

Showing Selected Profile

| Valid for option/configuration | | | |
|--------------------------------|------------|--------|------------------------|
| Model | Option no. | Option | Configuration |
| L250G Volvo | 85420 | Engine | D13H US Tier 4 interim |
| L250G Volvo | 85421 | Engine | D13H EU Stage IIIB |

| Valid for serial numbers | | | |
|--------------------------|-----------------|---------------------|--------------------|
| Model | Production site | Serial number start | Serial number stop |
| L250G Volvo | Arvika | 3001 | 3251 |
| L250G Volvo | Arvika | 3252 | 9999 |

| | |
|------------------|---------------------------------|
| Radial clearance | 0.254–0.356 mm (0.010–0.014 in) |
| Axial clearance | 0.025–0.127 mm (0.001–0.005 in) |

| | | | |
|--|-------------------------------|---|---------------------------|
| Document Title: Turbocharger, specifications | Function Group: 030 | Information Type: Service Information | Date: 4/13/2026 |
| Profile: L250G Volvo | | | |

[Go back to Index Page](#)

Turbocharger, specifications

Showing Selected Profile

| Valid for option/configuration | | | |
|---------------------------------------|-------------------|---------------|----------------------|
| Model | Option no. | Option | Configuration |
| L250G Volvo | 85424 | Engine | D13F Stage II |

| Valid for serial numbers | | | |
|---------------------------------|------------------------|----------------------------|---------------------------|
| Model | Production site | Serial number start | Serial number stop |
| L250G Volvo | Arvika | 1001 | 1056 |
| L250G Volvo | Arvika | 1057 | 3000 |

| |
|--|
| Basic setting value: |
| 106 ±1 kPa (15.4 ±0.145 psi) gives a rocker arm movement of 3 ±0.3 mm (0.118 ±0.012 in). |

| | | | |
|--|-------------------------------|---|---------------------------|
| Document Title: Thermostat, specifications | Function Group: 030 | Information Type: Service Information | Date: 4/13/2026 |
| Profile: L250G Volvo | | | |

Thermostat, specifications

Showing Selected Profile

| Valid for serial numbers | | | |
|---------------------------------|------------------------|----------------------------|---------------------------|
| Model | Production site | Serial number start | Serial number stop |
| L250G Volvo | | | |

| Cooling system | |
|------------------------------|----------------|
| Thermostat begins to open at | 82 °C (180 °F) |
| Thermostat fully open at | 92 °C (198 °F) |

| | | | |
|---|-------------------------------|---|---------------------------|
| Document Title: Rocker arm shaft, shaft, tightening torques | Function Group: 030 | Information Type: Service Information | Date: 4/13/2026 |
| Profile: L250G Volvo | | | |

Rocker arm shaft, tightening torques

Showing Selected Profile

| Valid for serial numbers | | | |
|--------------------------|-----------------|---------------------|--------------------|
| Model | Production site | Serial number start | Serial number stop |
| L250G Volvo | | | |

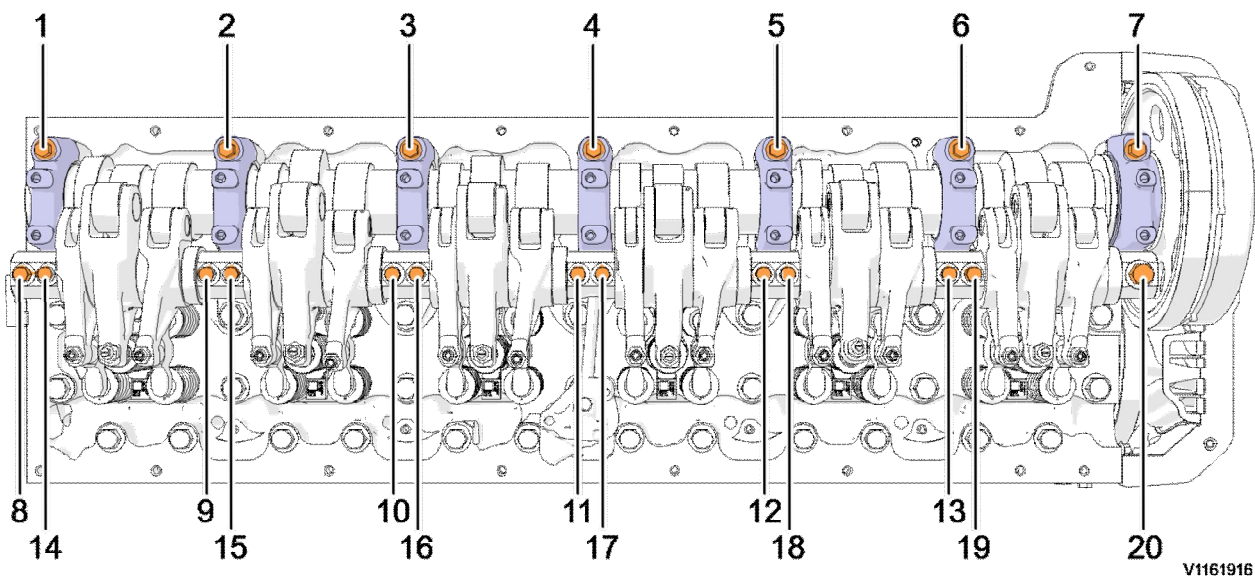

V1161916

Figure 1

| | |
|--|---------------------------|
| Camshaft and bearing caps in place | |
| Tighten the bolts 1–7 in the order 4, 3, 5, 2, 6, 1, 7. | 40 ±3 Nm (30 ±2.2 lbf ft) |
| Rocker arm shaft in place | |
| Step 1: Tighten the bolts 14–20 gradually in the order 17, 16, 18, 15, 19, 14, 20 until the rocker arm shaft is tighten to contact with the camshaft bearing caps. | |
| Step 2: Tighten the bolts 14–20 in the order 17, 16, 18, 15, 19, 14, 20. | 60 ±5 Nm (44 ±3.7 lbf ft) |
| Step 3: Angle-tighten the bolts 1–7 in the order 4, 3, 5, 2, 6, 1, 7. NOTE! Skip this step if the camshaft bearing caps has not been removed. | 90° ±5° |
| Step 4: Tighten the bolts 8–13 in the order 11, 10, 12, 9, 13, 8. | 40 ±3 Nm (30 ±2.2 lbf ft) |

| | |
|--|---------------------------|
| Step 5: Angle-tighten the bolts 8–13 in the order 11, 10, 12, 9, 13, 8. | 120° ±5° |
| Step 6: Loosen the bolts 14–19. | |
| Step 7: Tighten the bolts 14–19 in the order 17, 16, 18, 15, 19, 14. | 40 ±3 Nm (30 ±2.2 lbf ft) |
| Step 8: Angle-tighten the bolts 14–20 in the order 17, 16, 18, 15, 19, 14, 20. | 120° ±5° |

| | | | |
|---|-------------------------------|---|---------------------------|
| Document Title: Tightening torques, valve cover | Function Group: 030 | Information Type: Service Information | Date: 4/13/2026 |
| Profile: L250G Volvo | | | |

Valve cover, tightening torques

Showing Selected Profile

| Valid for serial numbers | | | |
|--------------------------|-----------------|---------------------|--------------------|
| Model | Production site | Serial number start | Serial number stop |
| L250G Volvo | | | |

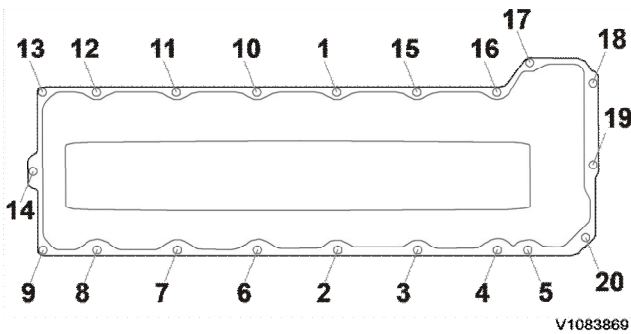

Figure 1
Figure 1 **Tightening diagram, valve cover**

| Valve cover | |
|---------------------|---------------------------|
| Valve cover, screws | 25 ± 3 Nm (18 ± 2 lbf ft) |

| | | | |
|--|-------------------------------|---|---------------------------|
| Document Title: Exhaust manifold, tightening torques | Function Group: 030 | Information Type: Service Information | Date: 4/13/2026 |
| Profile: L250G Volvo | | | |

[Go back to Index Page](#)

Exhaust manifold, tightening torques

Showing Selected Profile

| Valid for option/configuration | | | |
|--------------------------------|------------|--------|------------------------|
| Model | Option no. | Option | Configuration |
| L250G Volvo | 85420 | Engine | D13H US Tier 4 interim |
| L250G Volvo | 85421 | Engine | D13H EU Stage IIIB |

| Valid for serial numbers | | | |
|--------------------------|-----------------|---------------------|--------------------|
| Model | Production site | Serial number start | Serial number stop |
| L250G Volvo | Arvika | 3001 | 3251 |
| L250G Volvo | Arvika | 3252 | 9999 |

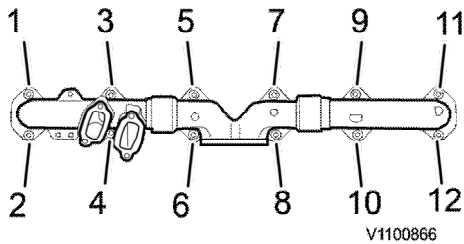

Figure 1

| | |
|--|----------------------------|
| Step 1: | |
| Tighten bolts 1, 4, and 5, 8, and 9, 12 to contact | 10±1.5 Nm (7.4±1.1 lbf ft) |
| Step 2: | |
| Tighten bolts 3 and 2 | 48±8 Nm (35.4±5.9 lbf ft) |
| Tighten bolts 7 and 6 | 48±8 Nm (35.4±5.9 lbf ft) |
| Tighten bolts 11 and 10 | 48±8 Nm (35.4±5.9 lbf ft) |
| Tighten bolts 1 and 4 | 48±8 Nm (35.4±5.9 lbf ft) |
| Tighten bolts 5 and 8 | 48±8 Nm (35.4±5.9 lbf ft) |
| Tighten bolts 9 and 12. | 48±8 Nm (35.4±5.9 lbf ft) |

| | | | |
|--|-------------------------------|---|---------------------------|
| Document Title: Exhaust manifold, tightening torques | Function Group: 030 | Information Type: Service Information | Date: 4/13/2026 |
| Profile: L250G Volvo | | | |

[Go back to Index Page](#)

Exhaust manifold, tightening torques

Showing Selected Profile

| Valid for option/configuration | | | |
|--------------------------------|------------|--------|---------------|
| Model | Option no. | Option | Configuration |
| L250G Volvo | 85424 | Engine | D13F Stage II |

| Valid for serial numbers | | | |
|--------------------------|-----------------|---------------------|--------------------|
| Model | Production site | Serial number start | Serial number stop |
| L250G Volvo | Arvika | 1001 | 1056 |
| L250G Volvo | Arvika | 1057 | 3000 |

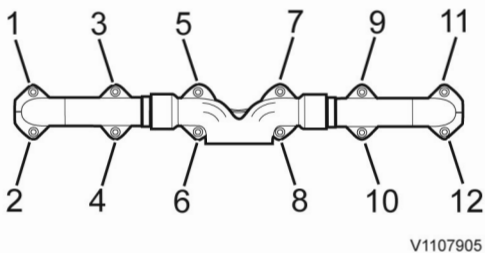

Figure 1

| | |
|--|----------------------------|
| Step 1: | |
| Tighten bolts 1, 4, and 5, 8, and 9, 12 to contact | 10±1.5 Nm (7.4±1.1 lbf ft) |
| Step 2: | |
| Tighten bolts 3 and 2 | 48±8 Nm (35.4±5.9 lbf ft) |
| Tighten bolts 7 and 6 | 48±8 Nm (35.4±5.9 lbf ft) |
| Tighten bolts 11 and 10 | 48±8 Nm (35.4±5.9 lbf ft) |
| Tighten bolts 1 and 4 | 48±8 Nm (35.4±5.9 lbf ft) |
| Tighten bolts 5 and 8 | 48±8 Nm (35.4±5.9 lbf ft) |
| Tighten bolts 9 and 12. | 48±8 Nm (35.4±5.9 lbf ft) |

| | | | |
|--|-------------------------------|---|---------------------------|
| Document Title: EGR system, tightening torques | Function Group: 030 | Information Type: Service Information | Date: 4/13/2026 |
| Profile: L250G Volvo | | | |

EGR system, tightening torques

Showing Selected Profile

| Valid for option/configuration | | | |
|--------------------------------|------------|--------|------------------------|
| Model | Option no. | Option | Configuration |
| L250G Volvo | 85420 | Engine | D13H US Tier 4 interim |
| L250G Volvo | 85421 | Engine | D13H EU Stage IIIB |

| Valid for serial numbers | | | |
|--------------------------|-----------------|---------------------|--------------------|
| Model | Production site | Serial number start | Serial number stop |
| L250G Volvo | Arvika | 3001 | 3251 |
| L250G Volvo | Arvika | 3252 | 9999 |

| | |
|---|--|
| V-clamp, EGR-valve | 20 ±4 Nm (15 ±2.9 lbf ft) |
| Flange bolt, EGR-valve (exhaust manifold) Tighten the bolts crosswise! | Step 1: 20 ±4 Nm (15 ±2.9 lbf ft) Step 2: 61 ±3 Nm (45 ±2.2 lbf ft) |
| Oil pressure hose | |
| Fitting nut | 25 ±4 Nm (18.4 ±3 lbs ft) |
| Hollow screw | 48 ±8 Nm (35.4 ±5.9 lbs ft) |

| | | | |
|---|-------------------------------|---|---------------------------|
| Document Title: Cooling fan rpm, specifications | Function Group: 030 | Information Type: Service Information | Date: 4/13/2026 |
| Profile: L250G Volvo | | | |

Cooling fan rpm, specifications

Showing Selected Profile

| Valid for serial numbers | | | |
|--------------------------|-----------------|---------------------|--------------------|
| Model | Production site | Serial number start | Serial number stop |
| L250G Volvo | | | |

VCADS Pro parameter GDR is used to set max. cooling fan speed by selecting sound reduction level (A, B, or C) depending on the demands for cooling of engine, charge-air, transmission, and hydraulic oil.

| Cooling fan | |
|-------------|---------|
| Min. rpm | 0 rpm |
| Base speed | 400 rpm |

| GDR | Max. cooling fan speed (rpm) at high idle | Description |
|-----|---|------------------|
| A | 1200 rpm | Low sound level |
| B | 1325 rpm | Standard cooling |
| C | 1550 rpm [1] | Maximal cooling |

Fan rpm in relation to engine rpm at pressure test

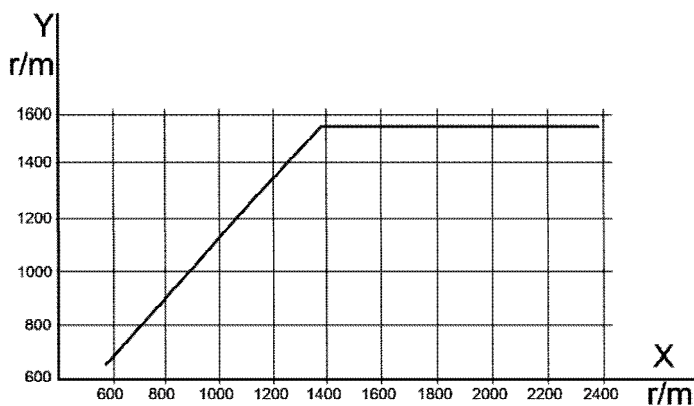

V1096609

Figure 1

Y-axis = Fan rpm

X-axis = Engine rpm

Pressure in relation to fan rpm

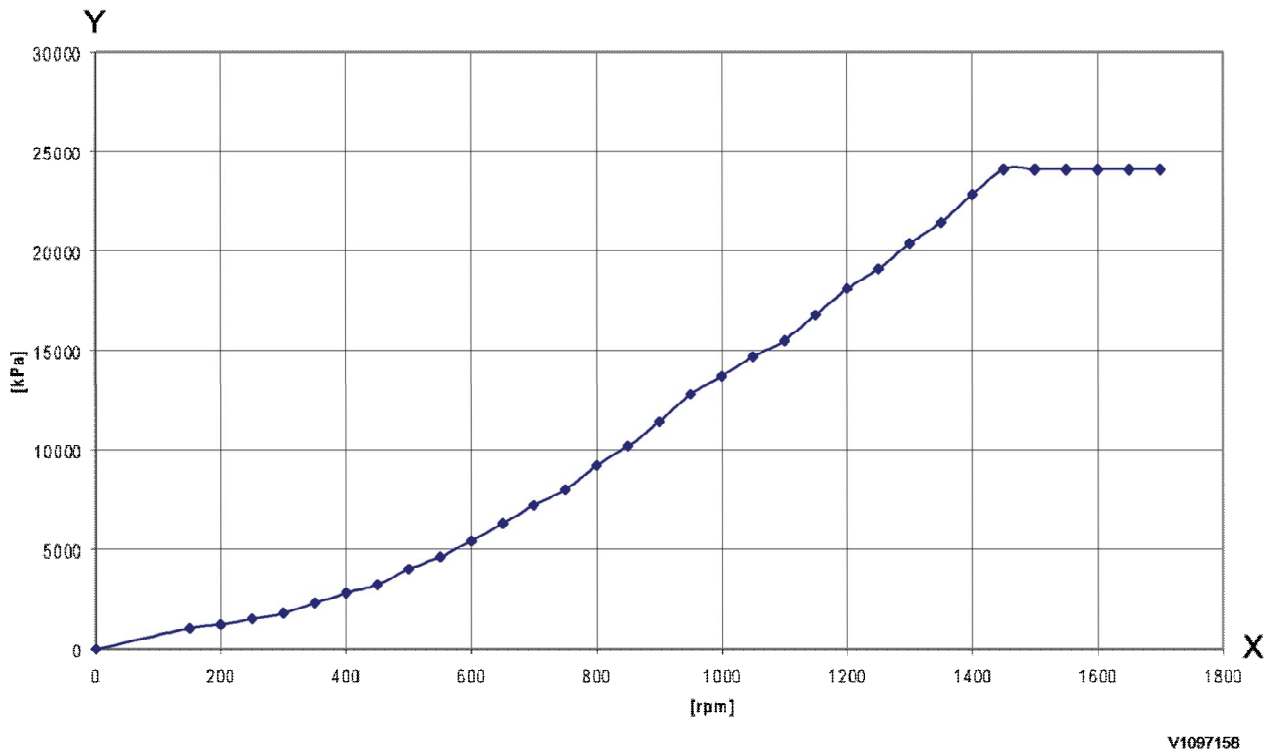

Figure 2
Pressure in relation to fan rpm (without axle oil cooler)

Y-axis = Pressure (kPa)
X-axis = Fan speed (rpm)

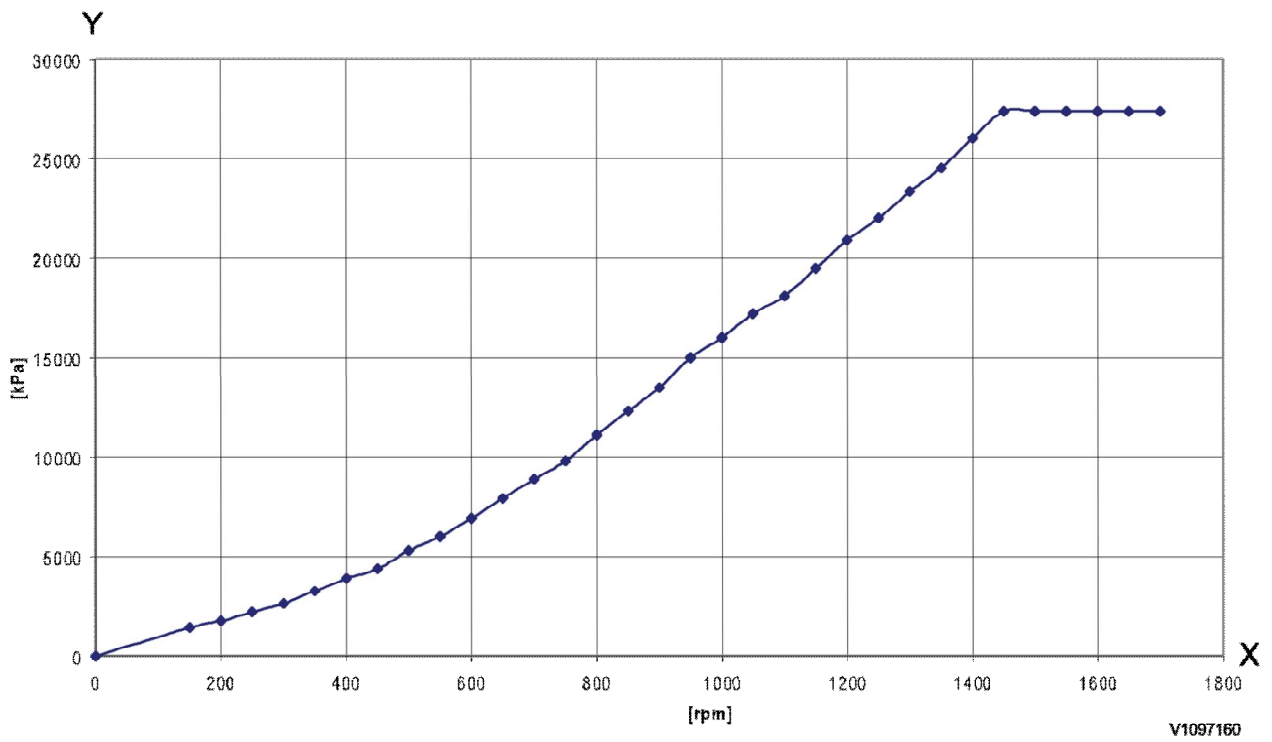

Figure 3
Pressure in relation to fan rpm (with axle oil cooler)

Y-axis = Pressure (kPa)

X-axis = Fan speed (rpm)

[1]1350 rpm if axle oil cooling is installed

| | | | |
|---|-------------------------------|---|---------------------------|
| Document Title: Conversion tables | Function Group: 030 | Information Type: Service Information | Date: 4/13/2026 |
| Profile: L250G Volvo | | | |

Conversion tables

Showing Selected Profile

| Valid for serial numbers | | | |
|--------------------------|-----------------|---------------------|--------------------|
| Model | Production site | Serial number start | Serial number stop |
| L250G Volvo | | | |

Length

| Unit | cm | m | km | in | ft | yd | mile |
|------|--------|--------|----------|---------|---------|---------|----------|
| cm | 1 | 0.01 | 0.00001 | 0.3937 | 0.03281 | 0.01094 | 0.000006 |
| m | 100 | 1 | 0.001 | 39.37 | 3.2808 | 1.0936 | 0.00062 |
| km | 100000 | 1000 | 1 | 39370.7 | 3280.8 | 1093.6 | 0.62137 |
| in | 2.54 | 0.0254 | 0.000025 | 1 | 0.08333 | 0.02777 | 0.000015 |
| ft | 30.48 | 0.3048 | 0.000304 | 12 | 1 | 0.3333 | 0.000189 |
| yd | 91.44 | 0.9144 | 0.000914 | 36 | 3 | 1 | 0.000568 |
| mile | 160930 | 1609.3 | 1.6093 | 63360 | 5280 | 1760 | 1 |

1 mm = 0.1 cm - 1 mm = 0.001 m

Area

| Unit | cm ² | m ² | km ² | a | ft ² | yd ² | in ² |
|-----------------|-----------------|----------------|-----------------|----------|-----------------|-----------------|-----------------|
| cm ² | 1 | 0.0001 | - | 0.000001 | 0.001076 | 0.000012 | 0.155000 |
| m ² | 10000 | 1 | 0.000001 | 0.01 | 10.764 | 1.1958 | 1550.000 |
| km ² | - | 1000000 | 1 | 10000 | 1076400 | 1195800 | - |
| a | 0.01 | 100 | 0.0001 | 1 | 1076.4 | 119.58 | - |
| ft ² | - | 0.092903 | - | 0.000929 | 1 | 0.1111 | 144.000 |
| yd ² | - | 0.83613 | - | 0.008361 | 9 | 1 | 1296.00 |
| in ² | 6.4516 | 0.000645 | - | - | 0.006943 | 0.000771 | 1 |

1 ha = 100 a - 1 mile² = 259 ha = 2.59 km²

Volume

| Unit | cm ³ = cc | m ³ | l | in ³ | ft ³ | yd ³ |
|----------------------|----------------------|----------------|---------|-----------------|-----------------|-----------------|
| cm ³ = ml | 1 | 0.000001 | 0.001 | 0.061024 | 0.000035 | 0.000001 |
| m ³ | 1000000 | 1 | 1000 | 61024 | 35.315 | 1.30796 |
| dm ³ (l) | 1000 | 0.001 | 1 | 61.024 | 0.035315 | 0.001308 |
| in ³ | 16.387 | 0.000016 | 0.01638 | 1 | 0.000578 | 0.000021 |
| ft ³ | 28316.8 | 0.028317 | 28.317 | 1728 | 1 | 0.03704 |
| yd ³ | 764529.8 | 0.76453 | 764.53 | 46656 | 27 | 1 |

1 gal (US) = 3785.41 cm³ = 231 in³ = 0.83267 gal (UK)

Weight

| Unit | g | kg | t | oz | lb |
|------|---------|---------|----------|---------|---------|
| g | 1 | 0.001 | 0.000001 | 0.03527 | 0.0022 |
| kg | 1000 | 1 | 0.001 | 35.273 | 2.20459 |
| t | 1000000 | 1000 | 1 | 35273 | 2204.59 |
| oz | 28.3495 | 0.02835 | 0.000028 | 1 | 0.0625 |
| lb | 453.592 | 0.45359 | 0.000454 | 16 | 1 |

1 ton (metric) = 1.1023 ton (US) = 0.9842 ton (UK)

Pressure

| Unit | kp/cm ² | bar | Pa=N/m ² | kPa | lbf/in ² | lbf/ft ² |
|---------------------|--------------------|---------|---------------------|---------|---------------------|---------------------|
| kp/cm ² | 1 | 0.98067 | 98066.5 | 98.0665 | 14.2233 | 2048.16 |
| bar | 1.01972 | 1 | 100000 | 100 | 14.5037 | 2088.6 |
| Pa=N/m ² | 0.00001 | 0.001 | 1 | 0.001 | 0.00015 | 0.02086 |
| kPa | 0.01020 | 0.01 | 1000 | 1 | 0.14504 | 20.886 |
| lbf/in ² | 0.07032 | 0.0689 | 6894.76 | 6.89476 | 1 | 144 |
| lbf/ft ² | 0.00047 | 0.00047 | 47.88028 | 0.04788 | 0.00694 | 1 |

kg/cm² = 735.56 Dry (mmHg) = 0.96784 atm

Unit explanations

| Unit | abbreviation |
|----------------------|--------------|
| Newton meter | Nm |
| Kilopoundmeter | kpm |
| Kilopascal | kPa |
| Megapascal | MPa |
| Kilowatt | kW |
| kilojoule | kJ |
| British thermal unit | Btu |
| Calorie | cal |

Approx. conversion

| SI unit | Conversion factor | Non SI | Conversion factor | SI |
|--|-------------------|----------------------|-------------------|---------------------|
| Torque | | | | |
| Nm | x10.2 | =kg/cm | x0.8664 | =lb in |
| Nm | x0.74 | =lbf-ft | x1.36 | =Nm |
| Nm | x0.102 | =kg/m | x7.22 | =lbft |
| Pressure (Pa = N/m²) | | | | |
| kPa | x4.0 | =in.H ₂ O | x0.249 | =kPa |
| kPa | x0.30 | =in.Hg | x3.38 | =kPa |
| kPa | x0.145 | =psi | x6.89 | =kPa |
| bar | x14.5 | =psi | x0.069 | =bar |
| kp/cm ² | x14.22 | =psi | x0.070 | =kp/cm ² |
| N/mm ² | x145.04 | =psi | x0.069 | =bar |
| MPa | x145 | =psi | x0.00689 | =MPa |
| Power (W = J/s) | | | | |
| kW | x1.36 | =hp(cv) | x0.736 | =kW |

| | | | | |
|--|--------|---------------------|---|--------------------|
| kW | x1.34 | = bhp | x0.746 | = kW |
| kW | x0.948 | = Btu/s | x1.055 | = kW |
| W | x0.74 | = ft-lb/s | x1.36 | = W |
| Energy (J = Nm) | | | | |
| kJ | x0.948 | = Btu | x1.055 | = kJ |
| J | x0.239 | = calorie | x4.19 | = J |
| Speed and acceleration | | | | |
| m/s ² | x3.28 | = ft/s ² | x0.305 | = m/s ² |
| m/s | x3.28 | = ft/s | x0.305 | = m/s |
| km/h | x0.62 | = mph | x1.61 | = km/h |
| Horsepower/torque | | | | |
| Bhp x5252 rpm = TQ (lb-ft) | | | TQ x rpm 5252 = bhp | |
| Temperature | | | | |
| $^{\circ}\text{C} = (^{\circ}\text{F} - 32) / 1.8$ | | | $^{\circ}\text{F} = (^{\circ}\text{C} \times 1.8) + 32$ | |
| Flow factor | | | | |
| l/min (dm ³ /min) | x0.264 | = US gal/min | x3.785 | = liter/min |

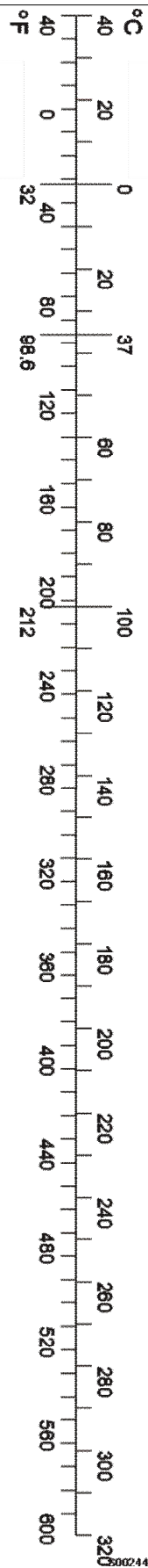

| | | | |
|---|-------------------------------|---|---------------------------|
| Document Title: Fuel system, specifications | Function Group: 030 | Information Type: Service Information | Date: 4/13/2026 |
| Profile: L250G Volvo | | | |

Fuel system, specifications

Showing Selected Profile

| Valid for serial numbers | | | |
|--------------------------|-----------------|---------------------|--------------------|
| Model | Production site | Serial number start | Serial number stop |
| L250G Volvo | | | |

| Fuel feed pump | |
|-------------------|-------------------------|
| Type | Gear pump |
| Feed pressure at: | |
| 600 rpm | min. 220 kPa (2.2 bar) |
| 1200 rpm | min. 375 kPa (3.75 bar) |

| Overflow valve | |
|--------------------|---------------------------|
| Opening pressure | 300-550 kPa (3 – 5.5 bar) |
| Tightening torques | 48± 5 Nm (35±3.7 lbf ft) |

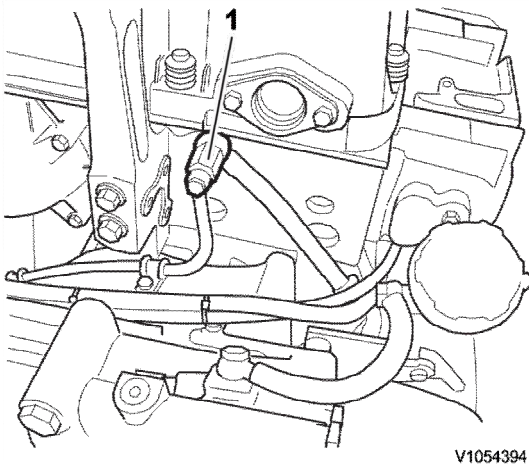

V1054394

Figure 1

The figure shows D16

1. Overflow valve

| | | | |
|--|-------------------------------|---|---------------------------|
| Document Title: Engine, specifications | Function Group: 030 | Information Type: Service Information | Date: 4/13/2026 |
| Profile: L250G Volvo | | | |

Engine, specifications

Showing Selected Profile

| Valid for serial numbers | | | |
|--------------------------|-----------------|---------------------|--------------------|
| Model | Production site | Serial number start | Serial number stop |
| L250G Volvo | | | |

General

| | |
|---------------------------|----------------------------|
| Number of cylinders | 6 |
| Cylinder bore | 131 mm (5.16 in) |
| Stroke | 158 mm (6.22 in) |
| Displacement | 12.78 litres (3.38 US gal) |
| Injection order | 1-5-3-6-2-4 |
| Low idle | |
| D13F | 700 rpm |
| D13H | 600 rpm |
| High idle (run out speed) | 2030 - 2070 rpm |
| Weight, engine | 1380 kg (3045 lbs) |

Stall speed torque converter⁽¹⁾

| | |
|---------------------------------------|---------------|
| L150G ⁽²⁾ | |
| HTL222B (22591) | 1670–1760 rpm |
| HTL222 (22586) | 1670–1760 rpm |
| HTL221 (22574) | 1740–1830 rpm |
| L180G, L180G HL ⁽²⁾ | |
| HTL222B (22591) | 1720–1810 rpm |
| HTL222 (22586) | 1720–1810 rpm |
| HTL221 (22574) | 1790–1870 rpm |
| L220G ⁽²⁾ | |
| HTL307 (22581) | 1780–1880 rpm |
| HTL306 (22575) | 1780–1880 rpm |
| L250G ⁽²⁾ | |
| HTL307 (22581) | 1830–1890 rpm |

(1) Shall be performed on gear 2, APS-mode service (manual), and without using the hydraulics.

(2) The transmission part number can be found in the machine card in PROSIS.

| | | | |
|---|-------------------------------|---|---------------------------|
| Document Title: Operation numbers for additional work | Function Group: 070 | Information Type: Service Information | Date: 4/13/2026 |
| Profile: Wheel Loaders (WLO) | | | |

Operation numbers for additional work

Showing Selected Profile

These operations can be used to identify work that is not included in the time guide or described in the methods in the Service Manual. When these operations are used, a description of the work that has been performed must be provided.

Other work related to engine

Op. no. 070-210

This operation can be used when work has been done related to the engine and function group 2 when no applicable method description was available. When this operation is used, additional information is required:

- Description of work that has been done

Other work related to electrical system

Op. no. 070-310

This operation can be used when work has been done related to the electrical system and function group 3 when no applicable method description was available. When this operation is used, additional information is required:

- Description of work that has been done

Other work related to transmission, gearbox, travel motor, swing motor

Op. no. 070-410

This operation can be used when work has been done related to the transmission, gearbox, travel motor or swing motor and function group 4 when no applicable method description was available. When this operation is used, additional information is required:

- Description of work that has been done

Other work related to drive axle

Op. no. 070-470

This operation can be used when work has been done related to the drive axle and function group 46 when no applicable method description was available. When this operation is used, additional information is required:

- Description of required work that have been done

Other work related to brake system

Op. no. 070-510

This operation can be used when work has been done related to the brake system and function group 5 when no applicable

method description was available. When this operation is used, additional information is required:

- Description of work that has been done

Other work related to steering system

Op. no. 070-610

This operation can be used when work has been done related to the steering system and function group 6 when no applicable method description was available. When this operation is used, additional information is required:

- Description of work that has been done

Other work related to frame link, axle suspension

Op. no. 070-710

This operation can be used when work has been done related to the frame link, axle suspension and other parts related to function group 7 when no applicable method description was available. When this operation is used, additional information is required:

- Description of work that has been done

Other work related to cab, air conditioning

Op. no. 070-810

This operation can be used when work has been done related to the cab, air conditioning and other parts related to function group 8 when no applicable method description was available. When this operation is used, additional information is required:

- Description of work that has been done

Other work related to hydraulic system

Op. no. 070-910

This operation can be used when work has been done related to the hydraulic system and other parts related to function group 9 when no applicable method description was available. When this operation is used, additional information is required:

- Description of work that has been done

| | | | |
|---|-------------------------------|---|---------------------------|
| Document Title: E1680, Holder | Function Group: 080 | Information Type: Service Information | Date: 4/13/2026 |
| Profile: L250G Volvo | | | |

E1680, Holder

Showing Selected Profile

| Valid for serial numbers | | | |
|--------------------------|-----------------|---------------------|--------------------|
| Model | Production site | Serial number start | Serial number stop |
| L250G Volvo | | | |

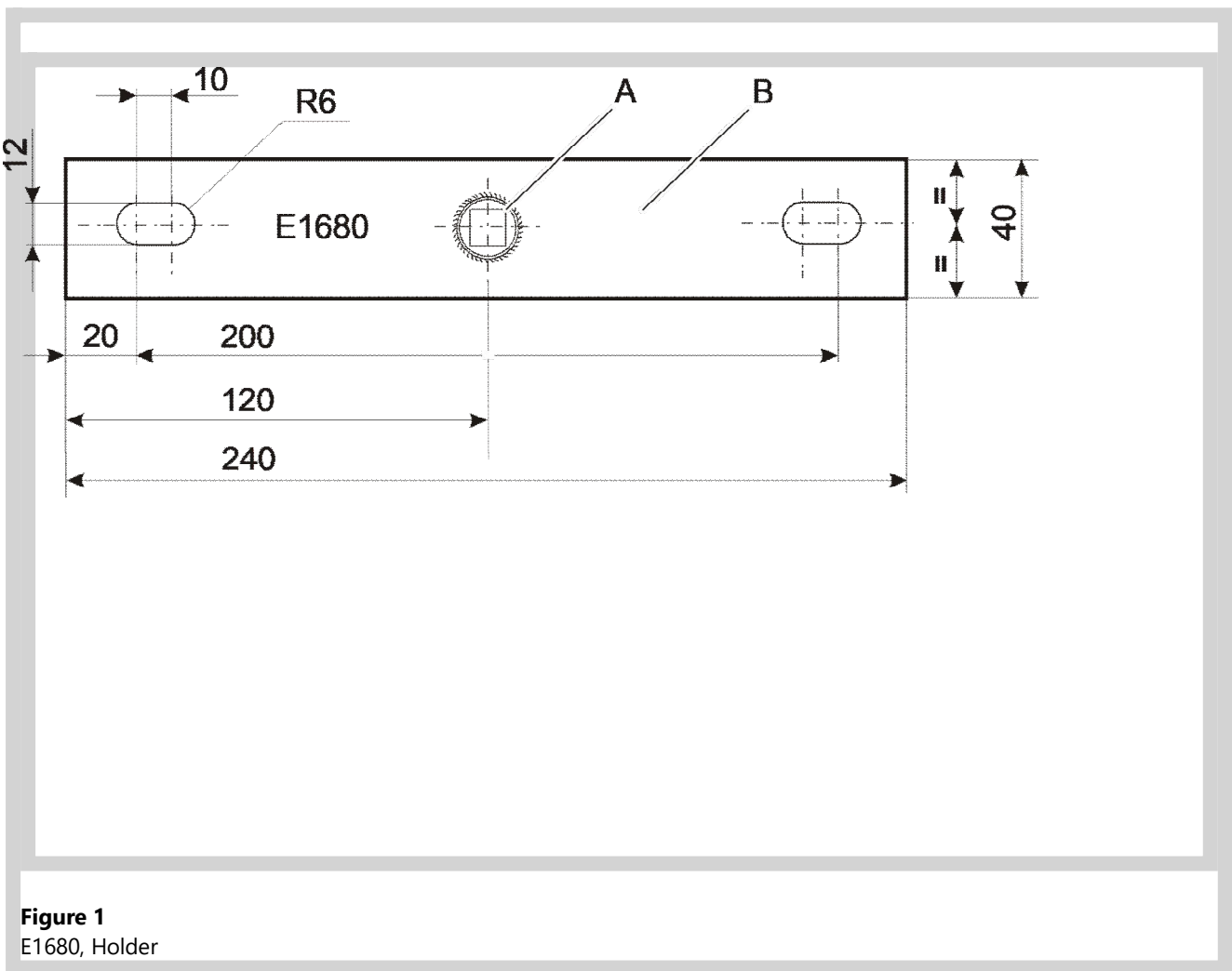

Figure 1
E1680, Holder

| | |
|---|--------------------|
| A | 1/2" Socket |
| B | Flat iron bar 5 mm |