

Document Title: Volvo standard tightening torques	Function Group: 030	Information Type: Service Information	Date: 4/11/2026
Profile: L180H Volvo			

Volvo standard tightening torques

Showing Selected Profile

Valid for serial numbers			
Model	Production site	Serial number start	Serial number stop
L180H Volvo			

The tightening torques in the following tables apply to bolts and nuts with tensile strength. The tables should be used as a general instruction for tightening bolts and nuts without specified values. The charts contains values for course thread bolts and nuts.

Torque values should be increased with $\approx 10\%$, for flange bolts.

All standard torques for bolts are without surface treatment.

The standard torque for bolts lubricated with oil should be reduced with 20% of the given value.

Standard tightening torque charts

Bolt size Metric Coarse Threads	Tensile strength 8.8		Tensile strength 10.9	
	(Nm)	(lbf ft)	(Nm)	(lbf ft)
M5	6	4	8	6
M6	10	7	14	11
M8	25	18	35	26
M10	50	37	70	52
M12	87	64	122	90
M14	139	103	195	144
M16	213	157	299	220
M18	293	216	413	305
M20	416	307	585	432
M24	719	530	1010	745
M27	1060	782	1490	1100
M30	1140	840	2025	1493
M36	2500	1844	3600	2653

Bolt size Inch SAE Coarse Threads	Tensile strength 5		Tensile strength 8	
	(lbf ft)	(Nm)	(lbf ft)	(Nm)
1/4	10	13,6	14	19
5/16	21	28,5	29	39,3
3/8	37	50,2	52	70
7/16	59	80	84	114
1/2	90	122	128	174
9/16	130	176	184	250
5/8	200	271	284	388
3/4	270	365	388	524
7/8	340	460	487	657
1	410	551	584	791
1 1/8	490	662	700	938
1 1/4	570	772	816	1093
1 3/8	650	882	932	1258
1 1/2	730	992	1038	1423
1 3/4	810	1102	1144	1588
2	890	1212	1250	1743
2 1/4	970	1322	1356	1908
2 3/4	1050	1432	1462	2063
3	1130	1542	1568	2218
3 1/2	1210	1652	1674	2373
4	1290	1762	1780	2528
4 1/2	1370	1872	1886	2683
5	1450	1982	1992	2838
5 1/2	1530	2092	2098	2993
6	1610	2202	2204	3148
6 1/2	1690	2312	2310	3303
7	1770	2422	2416	3458
7 1/2	1850	2532	2522	3613
8	1930	2642	2628	3768
8 1/2	2010	2752	2734	3923
9	2090	2862	2840	4078
9 1/2	2170	2972	2946	4233
10	2250	3082	3052	4388
10 1/2	2330	3192	3158	4543
11	2410	3302	3264	4698
11 1/2	2490	3412	3370	4853
12	2570	3522	3476	5008
12 1/2	2650	3632	3582	5163
13	2730	3742	3688	5318
13 1/2	2810	3852	3794	5473
14	2890	3962	3900	5628
14 1/2	2970	4072	4006	5783
15	3050	4182	4112	5938
15 1/2	3130	4292	4218	6093
16	3210	4402	4324	6248
16 1/2	3290	4512	4430	6403
17	3370	4622	4536	6558
17 1/2	3450	4732	4642	6713
18	3530	4842	4748	6868
18 1/2	3610	4952	4854	7023
19	3690	5062	4960	7178
19 1/2	3770	5172	5066	7333
20	3850	5282	5172	7488
20 1/2	3930	5392	5278	7643
21	4010	5502	5384	7798
21 1/2	4090	5612	5490	7953
22	4170	5722	5596	8108
22 1/2	4250	5832	5702	8263
23	4330	5942	5808	8418
23 1/2	4410	6052	5914	8573
24	4490	6162	6020	8728
24 1/2	4570	6272	6126	8883
25	4650	6382	6232	9038
25 1/2	4730	6492	6338	9193
26	4810	6602	6444	9348
26 1/2	4890	6712	6550	9503
27	4970	6822	6656	9658
27 1/2	5050	6932	6762	9813
28	5130	7042	6868	9968
28 1/2	5210	7152	6974	10123
29	5290	7262	7080	10278
29 1/2	5370	7372	7186	10433
30	5450	7482	7292	10588
30 1/2	5530	7592	7398	10743
31	5610	7702	7504	10898
31 1/2	5690	7812	7610	11053
32	5770	7922	7716	11208
32 1/2	5850	8032	7822	11363
33	5930	8142	7928	11518
33 1/2	6010	8252	8034	11673
34	6090	8362	8140	11828
34 1/2	6170	8472	8246	11983
35	6250	8582	8352	12138
35 1/2	6330	8692	8458	12293
36	6410	8802	8564	12448
36 1/2	6490	8912	8670	12603
37	6570	9022	8776	12758
37 1/2	6650	9132	8882	12913
38	6730	9242	8988	13068
38 1/2	6810	9352	9094	13223
39	6890	9462	9200	13378
39 1/2	6970	9572	9306	13533
40	7050	9682	9412	13688
40 1/2	7130	9792	9518	13843
41	7210	9902	9624	14008
41 1/2	7290	10012	9730	14163
42	7370	10122	9836	14318
42 1/2	7450	10232	9942	14473
43	7530	10342	10048	14628
43 1/2	7610	10452	10154	14783
44	7690	10562	10260	14938
44 1/2	7770	10672	10366	15093
45	7850	10782	10472	15248
45 1/2	7930	10892	10578	15403
46	8010	11002	10684	15558
46 1/2	8090	11112	10790	15713
47	8170	11222	10896	15868
47 1/2	8250	11332	11002	16023
48	8330	11442	11108	16178
48 1/2	8410	11552	11214	16333
49	8490	11662	11320	16488
49 1/2	8570	11772	11426	16643
50	8650	11882	11532	16798
50 1/2	8730	11992	11638	16953
51	8810	12102	11744	17108
51 1/2	8890	12212	11850	17263
52	8970	12322	11956	17418
52 1/2	9050	12432	12062	17573
53	9130	12542	12168	17728
53 1/2	9210	12652	12274	17883
54	9290	12762	12380	18038
54 1/2	9370	12872	12486	18193
55	9450	12982	12592	18348
55 1/2	9530	13092	12698	18503
56	9610	13202	12804	18658
56 1/2	9690	13312	12910	18813
57	9770	13422	13016	18968
57 1/2	9850	13532	13122	19123
58	9930	13642	13228	19278
58 1/2	10010	13752	13334	19433
59	10090	13862	13440	19588
59 1/2	10170	13972	13546	19743
60	10250	14082	13652	19898
60 1/2	10330	14192	13758	20053
61	10410	14302	13864	20208
61 1/2	10490	14412	13970	20363
62	10570	14522	14076	20518
62 1/2	10650	14632	14182	20673
63	10730	14742	14288	20828
63 1/2	10810	14852	14394	20983
64	10890	14962	14500	21138
64 1/2	10970	15072	14606	21293
65	11050	15182	14712	21448
65 1/2	11130	15292	14818	21603
66	11210	15402	14924	21758
66 1/2	11290	15512	15030	21913
67	11370	15622	15136	22068
67 1/2	11450	15732	15242	22223
68	11530	15842	15348	22378
68 1/2	11610	15952	15454	22533
69	11690	16062	15560	22688
69 1/2	11770	16172	15666	22843
70	11850	16282	15772	22998
70 1/2	11930	16392	15878	23153
71	12010	16502	15984	23308
71 1/2	12090	16612	16090	23463
72	12170	16722	16196	23618
72 1/2	12250	16832	16302	23773
73	12330	16942	16408	23928
73 1/2	12410	17052	16514	24083
74	12490	17162	16620	24238
74 1/2	12570	17272	16726	24393
75	12650	17382	16832	24548
75 1/2	12730	17492	16938	24703
76	12810	17602	17044	24858
76 1/2	12890	17712	17150	25013
77	12970	17822	17256	25168
77 1/2	13050	17932	17362	25323
78	13130	18042	17468	25478
78 1/2	13210	18152	17574	25633
79	13290	18262	17680	25788
79 1/2	13370	18372	17786	25943
80	13450	18482	17892	26098
80 1/2	13530	18592	17998	26253
81	13610	18702	18104	26408
81 1/2	13690	18812	18210	26563
82	13770	18922	18316	26718
82 1/2	13850	19032	18422	26873
83	13930	19142	18528	27028
83 1/2	14010	19252	18634	27183
84	14090	19362	18740	27338
84 1/2	14170	19472	18846	27493
85	14250	19582	18952	27648
85 1/2	14330	19692	19058	27803
86	14410	19802	19164	27958
86 1/2	14490	19912	19270	28113
87	14570	20022	19376	28268
87 1/2	14650	20132	19482	28423
88	14730	20242	19588	28578
88 1/2	14810	20352	19694	28733
89	14890	20462	19800	28888
89 1/2	14970	20572	19906	29043
90	15050	20682	20012	29198
90 1/2	15130	20792	20118	29353
91	15210	20902	20224	29508
91 1/2	15290	21012	20330	29663
92	15370	21122	20436	29818
92 1/2	15450	21232	20542	29973
93	15530	21342	20648	30128
93 1/2	15610	21452	20754	30283
94	15690	21562	20860	30438
94 1/2	15770	21672	20966	30593
95	15850	21782	21072	30748
95 1/2	15930	21892	21178	30903
96	16010	22002	21284	31058
96 1/2	16090	22112	21390	31213
97	16170	222		

Product: L180H Volvo Wheel Loaders Service Manual

Full Download: <https://www.arepairmanual.com/downloads/l180h-volvo-wheel-loaders-service-manual/>

3/4	320	434	451	612
7/8	515	700	728	988
1	775	1052	1091	1480
1 1/8	953	1290	1545	2100
1 1/4	1344	1823	2180	2960
1 3/8	1600	2170	2650	3600
1 1/2	2000	2714	3200	4340

Sample manual. Download All 4970 pages at:

<https://www.arepairmanual.com/downloads/l180h-volvo-wheel-loaders-service-manual/>

Document Title: Conversion tables	Function Group: 030	Information Type: Service Information	Date: 4/11/2026
Profile: L180H Volvo			

Conversion tables

Showing Selected Profile

Valid for serial numbers			
Model	Production site	Serial number start	Serial number stop
L180H Volvo			

Length

Unit	cm	m	km	in	ft	yd	mile
cm	1	0.01	0.00001	0.3937	0.03281	0.01094	0.000006
m	100	1	0.001	39.37	3.2808	1.0936	0.00062
km	100000	1000	1	39370.7	3280.8	1093.6	0.62137
in	2.54	0.0254	0.000025	1	0.08333	0.02777	0.000015
ft	30.48	0.3048	0.000304	12	1	0.3333	0.000189
yd	91.44	0.9144	0.000914	36	3	1	0.000568
mile	160930	1609.3	1.6093	63360	5280	1760	1

1 mm = 0.1 cm - 1 mm = 0.001 m

Area

Unit	cm ²	m ²	km ²	a	ft ²	yd ²	in ²
cm ²	1	0.0001	-	0.000001	0.001076	0.000012	0.155000
m ²	10000	1	0.000001	0.01	10.764	1.1958	1550.000
km ²	-	1000000	1	10000	1076400	1195800	-
a	0.01	100	0.0001	1	1076.4	119.58	-
ft ²	-	0.092903	-	0.000929	1	0.1111	144.000
yd ²	-	0.83613	-	0.008361	9	1	1296.00
in ²	6.4516	0.000645	-	-	0.006943	0.000771	1

1 ha = 100 a - 1 mile² = 259 ha = 2.59 km²

Volume

Unit	cm ³ = cc	m ³	l	in ³	ft ³	yd ³
cm ³ = ml	1	0.000001	0.001	0.061024	0.000035	0.000001
m ³	1000000	1	1000	61024	35.315	1.30796
dm ³ (l)	1000	0.001	1	61.024	0.035315	0.001308
in ³	16.387	0.000016	0.01638	1	0.000578	0.000021
ft ³	28316.8	0.028317	28.317	1728	1	0.03704
yd ³	764529.8	0.76453	764.53	46656	27	1

1 gal (US) = 3785.41 cm³ = 231 in³ = 0.83267 gal (UK)

Weight

Unit	g	kg	t	oz	lb
g	1	0.001	0.000001	0.03527	0.0022
kg	1000	1	0.001	35.273	2.20459
t	1000000	1000	1	35273	2204.59
oz	28.3495	0.02835	0.000028	1	0.0625
lb	453.592	0.45359	0.000454	16	1

1 ton (metric) = 1.1023 ton (US) = 0.9842 ton (UK)

Pressure

Unit	kp/cm ²	bar	Pa=N/m ²	kPa	lbf/in ²	lbf/ft ²
kp/cm ²	1	0.98067	98066.5	98.0665	14.2233	2048.16
bar	1.01972	1	100000	100	14.5037	2088.6
Pa=N/m ²	0.00001	0.001	1	0.001	0.00015	0.02086
kPa	0.01020	0.01	1000	1	0.14504	20.886
lbf/in ²	0.07032	0.0689	6894.76	6.89476	1	144
lbf/ft ²	0.00047	0.00047	47.88028	0.04788	0.00694	1

kg/cm² = 735.56 Dry (mmHg) = 0.96784 atm

Unit explanations

Unit	abbreviation
Newton meter	Nm
Kilopoundmeter	kpm
Kilopascal	kPa
Megapascal	MPa
Kilowatt	kW
kilojoule	kJ
British thermal unit	Btu
Calorie	cal

Approx. conversion

SI unit	Conversion factor	Non SI	Conversion factor	SI
Torque				
Nm	x10.2	=kg/cm	x0.8664	=lb in
Nm	x0.74	=lbf-ft	x1.36	=Nm
Nm	x0.102	=kg/m	x7.22	=lbft
Pressure (Pa = N/m²)				
kPa	x4.0	=in.H ₂ O	x0.249	=kPa
kPa	x0.30	=in.Hg	x3.38	=kPa
kPa	x0.145	=psi	x6.89	=kPa
bar	x14.5	=psi	x0.069	=bar
kp/cm ²	x14.22	=psi	x0.070	=kp/cm ²
N/mm ²	x145.04	=psi	x0.069	=bar
MPa	x145	=psi	x0.00689	=MPa
Power (W = J/s)				
kW	x1.36	=hp(cv)	x0.736	=kW

kW	x1.34	= bhp	x0.746	= kW
kW	x0.948	= Btu/s	x1.055	= kW
W	x0.74	= ft-lb/s	x1.36	= W
Energy (J = Nm)				
kJ	x0.948	= Btu	x1.055	= kJ
J	x0.239	= calorie	x4.19	= J
Speed and acceleration				
m/s ²	x3.28	= ft/s ²	x0.305	= m/s ²
m/s	x3.28	= ft/s	x0.305	= m/s
km/h	x0.62	= mph	x1.61	= km/h
Horsepower/torque				
Bhp x5252 rpm = TQ (lb-ft)			TQ x rpm 5252 = bhp	
Temperature				
$^{\circ}\text{C} = (^{\circ}\text{F} - 32) / 1.8$			$^{\circ}\text{F} = (^{\circ}\text{C} \times 1.8) + 32$	
Flow factor				
l/min (dm ³ /min)	x0.264	= US gal/min	x3.785	= liter/min

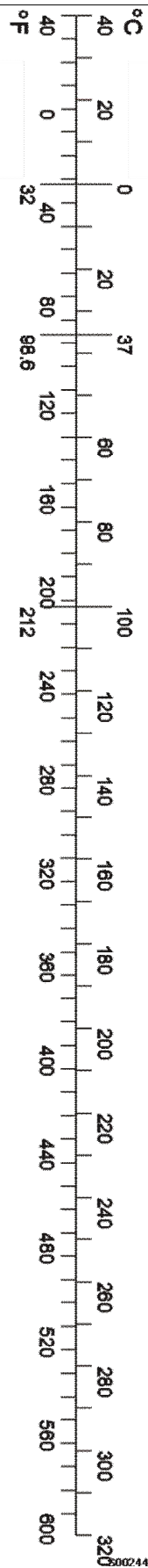

Document Title: Torque wrench extension	Function Group: 030	Information Type: Service Information	Date: 4/11/2026
Profile: L180H Volvo			

Torque wrench extension

Showing Selected Profile

Valid for serial numbers			
Model	Production site	Serial number start	Serial number stop
L180H Volvo			

When an extension is used together with a torque wrench (e.g.88830381 Wrench), the torque applied to the screw increases since the lever arm is extended.

The following formula is used to calculate the correct torque wrench settings:

$$M1 = M2 \times (L1/L2)$$

M1 is the torque to be set on the torque wrench.

L1 is the normal length of the torque wrench.

M2 is the tightening torque according to specification.

L2 is the total length of the torque wrench and extension.

NOTE!

The extension and the torque wrench must be in a straight line for the calculation to be correct.

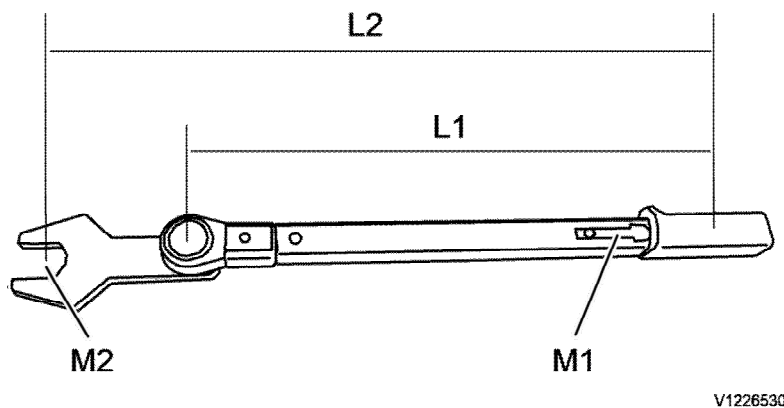

V1226530

Figure 1

Calculation example

M1 is the torque to be set on the torque wrench.

M2 is the tightening torque according to specification, e.g. 100 Nm.

L1 is the measured length of the torque wrench, e.g. 45 cm.

L2 is the measured length of the extension and the torque wrench, e.g. 60 cm.

L1 = 45 cm

L2 = 60 cm

M2 = 100 Nm

$$M1 = 100 \text{ Nm} \times (45 \text{ cm}/60 \text{ cm}) = 75 \text{ Nm}$$

Document Title: Operation numbers for additional work	Function Group: 070	Information Type: Service Information	Date: 4/11/2026
Profile: Wheel Loaders (WLO)			

Operation numbers for additional work

Showing Selected Profile

These operations can be used to identify work that is not included in the time guide or described in the methods in the Service Manual. When these operations are used, a description of the work that has been performed must be provided.

Other work related to engine

Op. no. 070-210

This operation can be used when work has been done related to the engine and function group 2 when no applicable method description was available. When this operation is used, additional information is required:

- Description of work that has been done

Other work related to electrical system

Op. no. 070-310

This operation can be used when work has been done related to the electrical system and function group 3 when no applicable method description was available. When this operation is used, additional information is required:

- Description of work that has been done

Other work related to transmission, gearbox, travel motor, swing motor

Op. no. 070-410

This operation can be used when work has been done related to the transmission, gearbox, travel motor or swing motor and function group 4 when no applicable method description was available. When this operation is used, additional information is required:

- Description of work that has been done

Other work related to drive axle

Op. no. 070-470

This operation can be used when work has been done related to the drive axle and function group 46 when no applicable method description was available. When this operation is used, additional information is required:

- Description of required work that have been done

Other work related to brake system

Op. no. 070-510

This operation can be used when work has been done related to the brake system and function group 5 when no applicable

method description was available. When this operation is used, additional information is required:

- Description of work that has been done

Other work related to steering system

Op. no. 070-610

This operation can be used when work has been done related to the steering system and function group 6 when no applicable method description was available. When this operation is used, additional information is required:

- Description of work that has been done

Other work related to frame link, axle suspension

Op. no. 070-710

This operation can be used when work has been done related to the frame link, axle suspension and other parts related to function group 7 when no applicable method description was available. When this operation is used, additional information is required:

- Description of work that has been done

Other work related to cab, air conditioning

Op. no. 070-810

This operation can be used when work has been done related to the cab, air conditioning and other parts related to function group 8 when no applicable method description was available. When this operation is used, additional information is required:

- Description of work that has been done

Other work related to hydraulic system

Op. no. 070-910

This operation can be used when work has been done related to the hydraulic system and other parts related to function group 9 when no applicable method description was available. When this operation is used, additional information is required:

- Description of work that has been done

Document Title: E1680, Holder	Function Group: 080	Information Type: Service Information	Date: 4/11/2026
Profile: L180H Volvo			

E1680, Holder

Showing Selected Profile

Valid for serial numbers			
Model	Production site	Serial number start	Serial number stop
L180H Volvo			

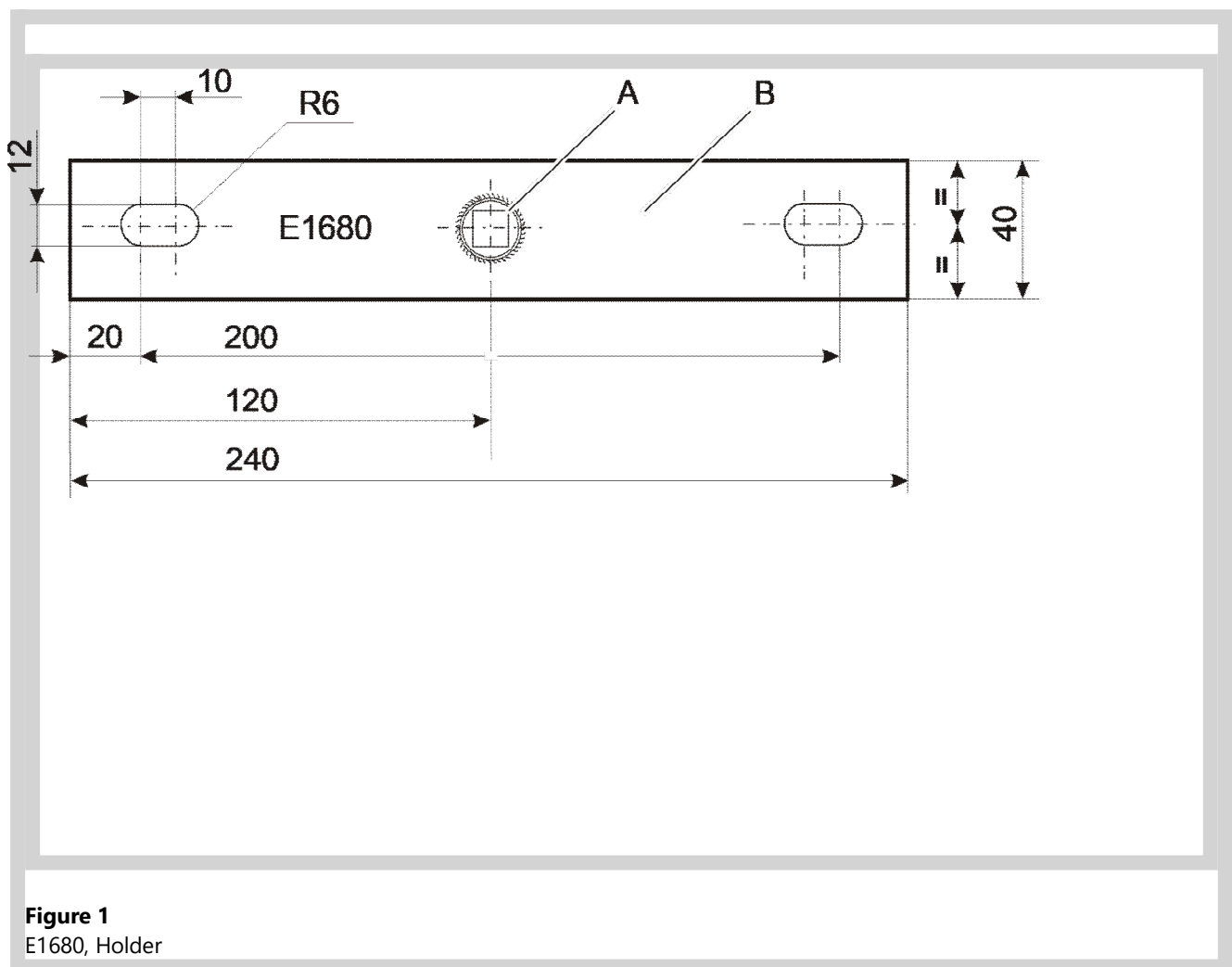

Figure 1
E1680, Holder

A	1/2" Socket
B	Flat iron bar 5 mm

Document Title: E 1708, Checking point	Function Group: 080	Information Type: Service Information	Date: 4/11/2026
Profile: L180H Volvo			

E 1708, Checking point

Showing Selected Profile

Valid for serial numbers			
Model	Production site	Serial number start	Serial number stop
L180H Volvo			

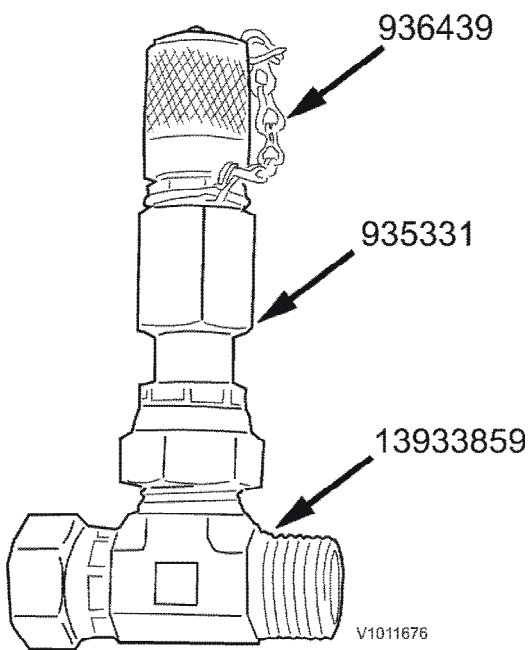

Figure 1

Document Title: E1711	Function Group: 080	Information Type: Service Information	Date: 4/11/2026
Profile: L180H Volvo			

E1711

Showing Selected Profile

Valid for serial numbers			
Model	Production site	Serial number start	Serial number stop
L180H Volvo			

E1711

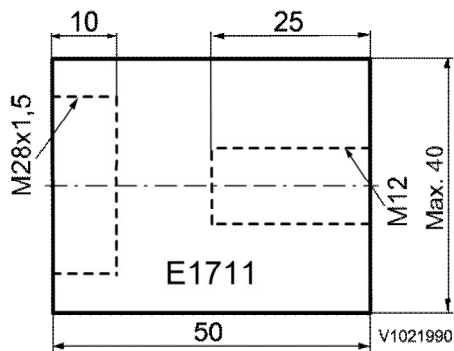

Figure 1

E1711

Document Title: E-2001	Function Group: 080	Information Type: Service Information	Date: 4/11/2026
Profile: L180H Volvo			

E-2001

Showing Selected Profile

Valid for serial numbers			
Model	Production site	Serial number start	Serial number stop
L180H Volvo			

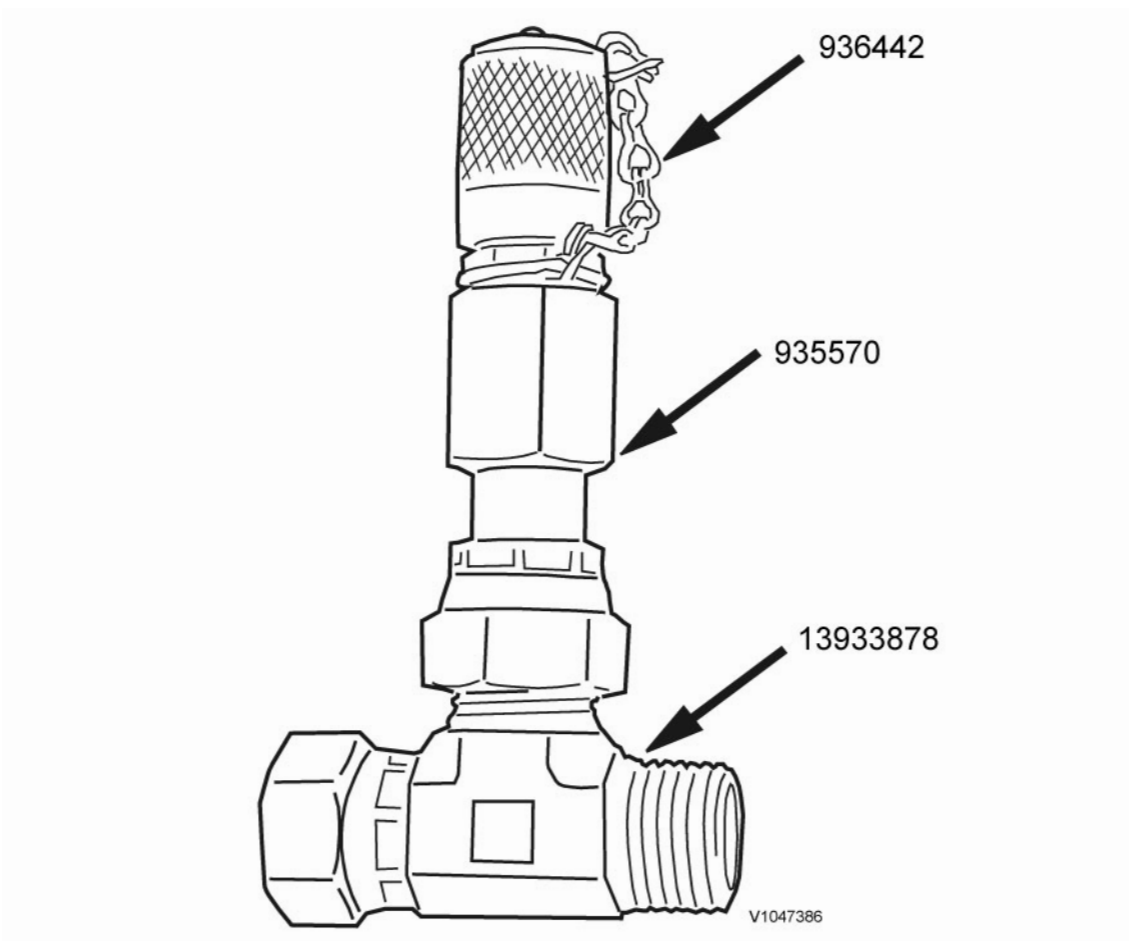

Figure 1

Document Title: E-2005	Function Group: 080	Information Type: Service Information	Date: 4/11/2026
Profile: L180H Volvo			

E-2005

Showing Selected Profile

Valid for serial numbers			
Model	Production site	Serial number start	Serial number stop
L180H Volvo			

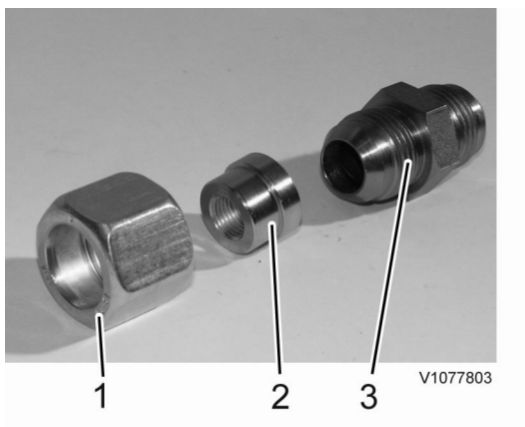

Figure 1

E-tool 2005

1. Coupling nut 931206
2. Test nipple 11054368 Thread R1/4"
3. Nipple 929315

Document Title: E-2007	Function Group: 080	Information Type: Service Information	Date: 4/11/2026
Profile: L180H Volvo			

E-2007

Showing Selected Profile

Valid for serial numbers			
Model	Production site	Serial number start	Serial number stop
L180H Volvo			



Figure 1

Document Title: E-2014	Function Group: 080	Information Type: Service Information	Date: 4/11/2026
Profile: L180H Volvo			

E-2014

Showing Selected Profile

Valid for serial numbers			
Model	Production site	Serial number start	Serial number stop
L180H Volvo			

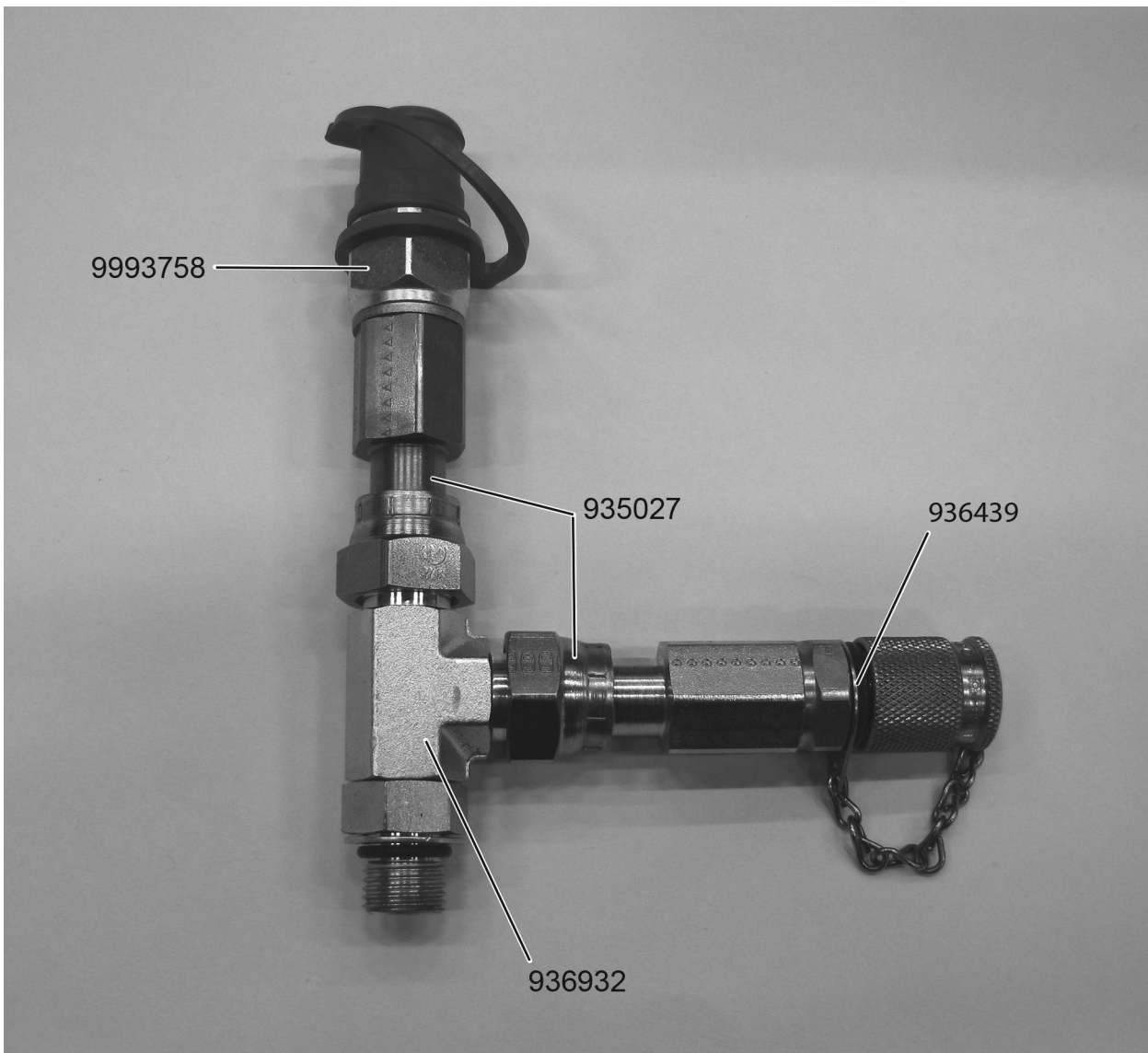

V1138633

Figure 1

Document Title: E-2015	Function Group: 080	Information Type: Service Information	Date: 4/11/2026
Profile: L180H Volvo			

E-2015

Showing Selected Profile

Valid for serial numbers			
Model	Production site	Serial number start	Serial number stop
L180H Volvo			

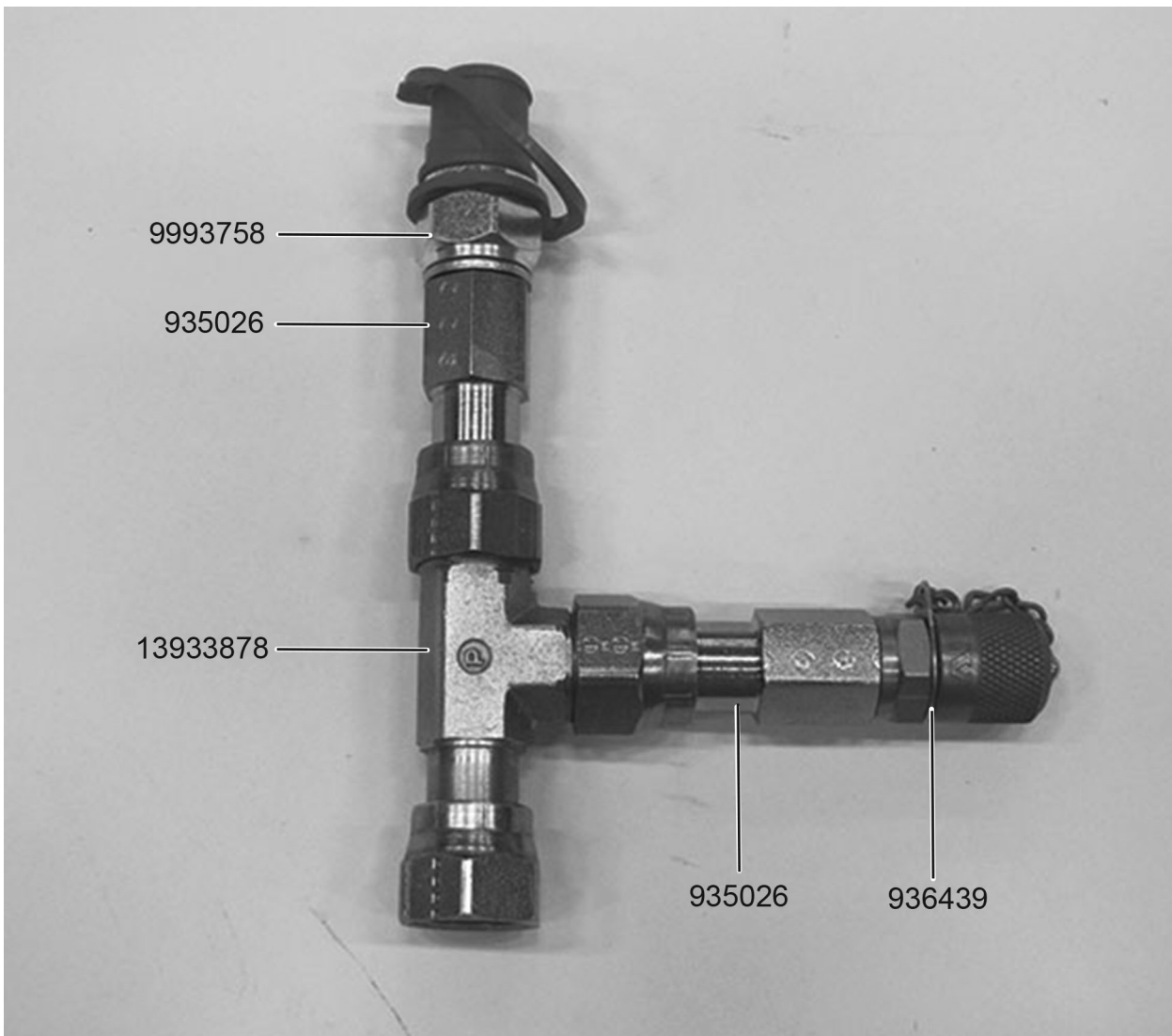

V1138746

Figure 1

Document Title: E-2016	Function Group: 080	Information Type: Service Information	Date: 4/11/2026
Profile: L180H Volvo			

E-2016

Showing Selected Profile

Valid for serial numbers			
Model	Production site	Serial number start	Serial number stop
L180H Volvo			

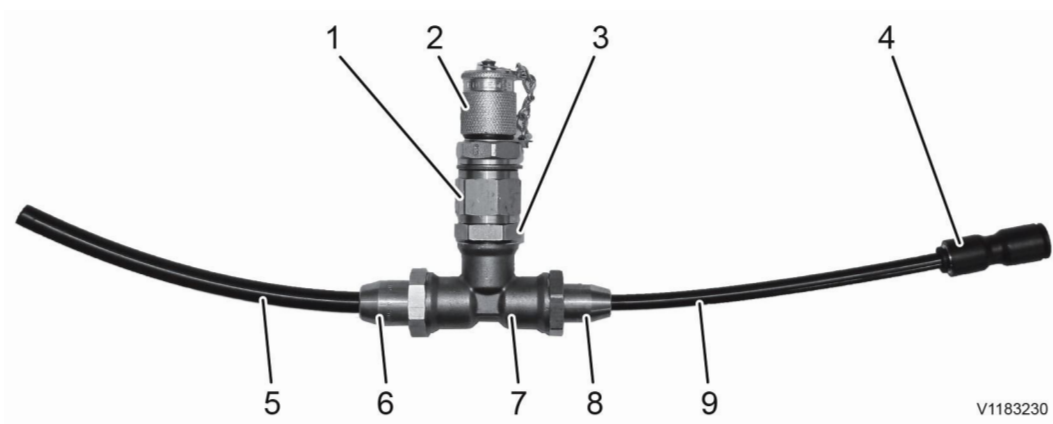

V1183230

Figure 1

1. 88830130 Nipple
2. 15018967 Testing nipple
3. 11196161 Nipple
4. 17413665 Connector Ø 6/8 mm
5. 980832 Tube Ø 8 mm
6. 977789 Fitting Ø 8 mm
7. 15023142 T-coupling
8. 979282 Fitting Ø 6 mm
9. 980831 Tube Ø 6mm

Document Title: E-2017	Function Group: 080	Information Type: Service Information	Date: 4/11/2026
Profile: L180H Volvo			

E-2017

Showing Selected Profile

Valid for option/configuration			
Model	Option no.	Option	Configuration
L180H Volvo	53217072	Engine	D13J China IV
L180H Volvo	85625	Engine	D13J EU Stage IV
L180H Volvo	85626	Engine	D13J US Tier 4 final
L180H Volvo	87231	Engine	D13J US Tier 4 final
L180H Volvo	87233	Engine	D13J EU Stage IV
L180H Volvo	87258	Engine	D13J US Tier 4 final
L180H Volvo	87726	Engine	D13J US Tier 4 final
L180H Volvo	87738	Engine	D13J EU Stage V

Valid for serial numbers			
Model	Production site	Serial number start	Serial number stop
L180H Volvo	Arvika	3001	5261
L180H Volvo	Arvika	5262	8000
L180H Volvo	Arvika	15001	23000

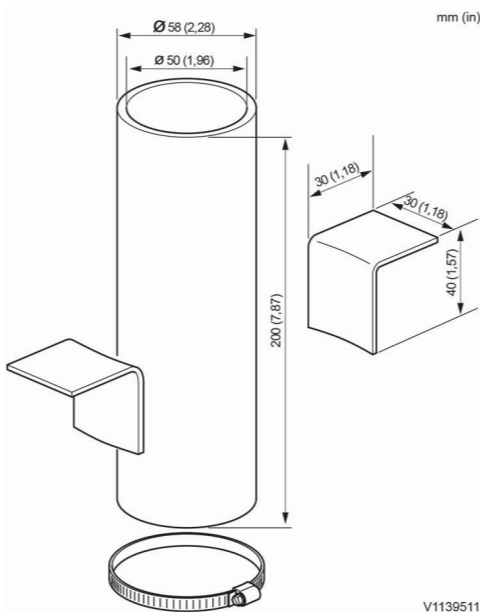

Figure 1

Document Title: E-2018	Function Group: 080	Information Type: Service Information	Date: 4/11/2026
Profile: L180H Volvo			

E-2018

Showing Selected Profile

Valid for serial numbers			
Model	Production site	Serial number start	Serial number stop
L180H Volvo			

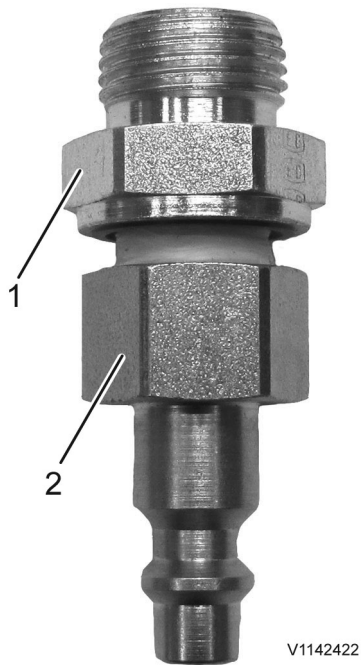

Figure 1

1. 963948
2. 17420996

Document Title: E-2037	Function Group: 080	Information Type: Service Information	Date: 4/11/2026
Profile: L180H Volvo			

E-2037

Showing Selected Profile

Valid for option/configuration			
Model	Option no.	Option	Configuration
L180H Volvo	53217072	Engine	D13J China IV
L180H Volvo	85625	Engine	D13J EU Stage IV
L180H Volvo	85626	Engine	D13J US Tier 4 final
L180H Volvo	87231	Engine	D13J US Tier 4 final
L180H Volvo	87233	Engine	D13J EU Stage IV
L180H Volvo	87258	Engine	D13J US Tier 4 final
L180H Volvo	87726	Engine	D13J US Tier 4 final
L180H Volvo	87738	Engine	D13J EU Stage V

Valid for serial numbers			
Model	Production site	Serial number start	Serial number stop
L180H Volvo	Arvika	3001	5261
L180H Volvo	Arvika	5262	8000
L180H Volvo	Arvika	15001	23000

Plate

Dimensions on the drawing are given in mm.

E-2037

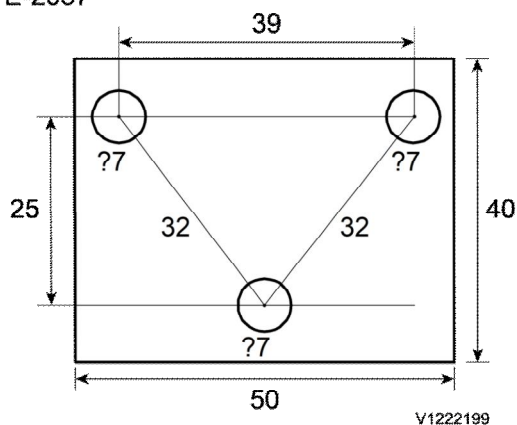

Figure 1

E-2037

Flat iron bar, thickness 6 mm

Document Title: E-2045	Function Group: 080	Information Type: Service Information	Date: 4/11/2026
Profile: L180H Volvo			

E-2045

Showing Selected Profile

Valid for serial numbers			
Model	Production site	Serial number start	Serial number stop
L180H Volvo			

Installation tool

Dimensions on the drawing are given in mm.

E-2045

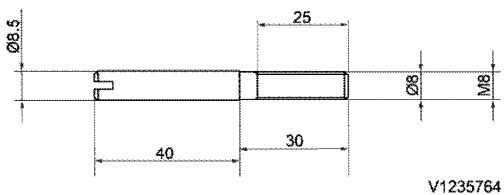
**Figure 1**

Material: S235JR

Document Title: 9993807 Lifting tool user instructions	Function Group: 080	Information Type: Service Information	Date: 4/11/2026
Profile: L180H Volvo			

9993807 Lifting tool user instructions

Showing Selected Profile

Valid for serial numbers			
Model	Production site	Serial number start	Serial number stop
L180H Volvo			

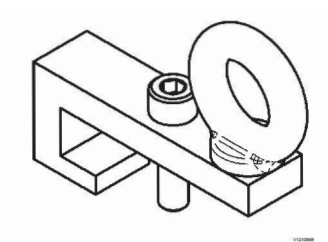

Figure 1

9993807 Lifting tool

Instructions

This instruction is a guide on how to use and maintain the lifting tool correctly. The instructions must be studied carefully by the personnel concerned before the lifting tool can be put into use.

The instructions must always be available to the personnel maintaining and using the lifting tool daily.

It is also important to:

- Keep the instructions and other applicable documents during the entire lifetime of the lifting tool.
- Pass the instructions to other owners or users of the lifting tool.
- Update the instructions with additions or changes made by the manufacturer.

Pay careful attention to information about warnings mentioned in the instructions and found on the warning signs on the lifting tools. If this information is not observed, severe personal injuries and equipment damage can arise.

Responsibility

The instructions describe the authorized method to use the lifting tool.

The lifting tool may only be used by personnel with adequate technical training or corresponding professional experience and in consultation with the manufacturer.

If the instructions have not been followed, the manufacturer is not responsible for personal injuries or damage to equipment.

Marking

Do not remove or make machine labels or other labels unreadable.

The lifting tool is marked with a CE mark, which means that it is designed, manufactured and described in accordance with EC Machinery Directive 2006/42/EC.

Warning decals and CE mark on lifting tool must be clearly visible. If a part provided with warning decals or CE mark is changed, a new warning decal and CE mark must be mounted in the same place. Defective decals and CE marks must be replaced immediately.



V1141218

Figure 2

CE-marking

Manufacturer

Company: Volvo Construction Equipment AB

Address: CE-46840, RLA 0301

Postal address: 631 85 Eskilstuna, Sweden

Rebuilding

If the lifting tool is rebuilt or supplemented with other parts without permission by the manufacturer, the CE marking does not include this part. If such rebuilding or added parts changes the function of the lifting tool, the CE marking in its entirety is no longer valid. After rebuilding, it is important that the instructions are supplemented with the necessary illustrations, photos and texts.

NOTE!

If not explicitly stated otherwise, always assume this instruction reference the use of two 9993807 Lifting tools.

Intended usage

The lifting toll specified in this document is only intended for lifting torque converters with a maximum weight of 100 kg. Intended users are appointed and trained personnel, the lifting gear is not intended to be used by unauthorised or underage personnel.

To fulfil the requirements for intended use, the user must follow all instructions and maintenance directions written by the manufacturer.

Technical data

Type designation: lifting tool for torque converter

Maximum load, lifting tool x 2: 100 kg (220 lb)

Mass, lifting tool x 2 with shackles and chain slings: 5 kg (11 lb)

Test factor for static testing (for lifting tools): 1.5

Safety information

Limits of use

The lifting tools may only be used for the intended purpose. All other use is forbidden.

Lifting hooks must be equipped with a self-locking hook.

Shackles should be used for connecting the tools.

Lifting sling and straps should be marked with lifting capacity.

All accessories for the lift must have sufficient lifting capacity.

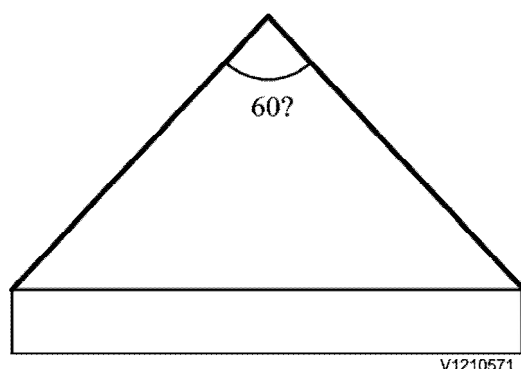

V1210571

Figure 3

Max lift-angle

Maximum lift angles must not exceed 60°.

Handling

To meet the requirements for intended use, the user must observe all user and maintenance instructions prescribed by the manufacturer.

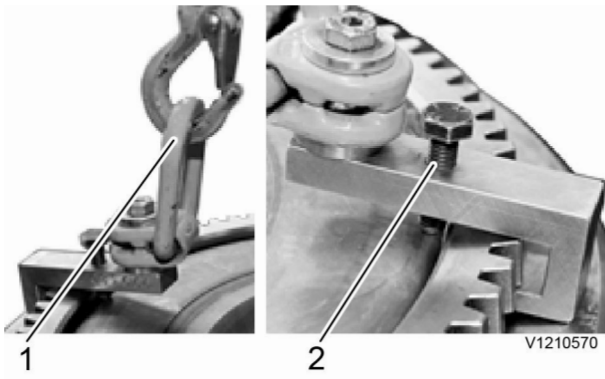

Figure 4

1. **Lifting equipment**
 Use lifting sling with sufficient lifting capacity, 100 kg (220 lb).
 Always use lifting hooks equipped with a self-locking hook.
 Use shackles with sufficient lifting capacity, 100 kg (220 lb).
2. **Bolts**
 Position the lifting tool under gear ring and tighten the bolts.
 Tighten until the lifting tool is unable to move independently of the gear ring.

Intended user

The lifting device is intended to be used by trained personnel, it is not intended to be used by unauthorized or underage personnel.

Conditions and preparatory measures

Lifting tool with damaged parts must not be used.
 Before lifting, check that the lifting tool does not have indications of cracks or deformations.

Maintenance

Maintenance must be performed by person with appropriate technical training or equivalent professional experience and in consultation with the manufacturer.

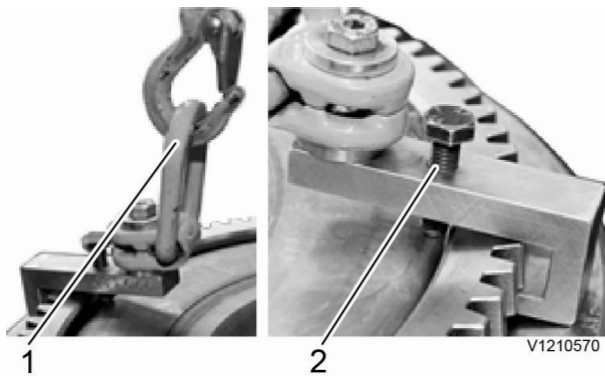

Figure 5

Detail/interval	Control/oversight
1 Shackles. Annual check.	Check that shackles does no have visible defects, cracks or deformations.
2 9993807 Lifting tool. Annual check.	Check that the lifting tool with threads and bolt does no have visible defects, cracks or deformations.

General

A defective lifting tool must be replaced.

Workplace

Protective shoes must be used.

The workplace should be kept free from equipment that can cause slipping or tripping risks.

The lifting tool is intended to be used in a workshop environment, outdoor usage is forbidden.

Continuous supervision

The lifting tool must be subjected to continuous supervision before use.

- Check for cracks.
- Check if the lifting tool is bent or deformed.
- Check that threaded screws and bolts are intact and do not have indications of breakage or deformation.

Document Title: 11668007 Lifting tool user instructions	Function Group: 080	Information Type: Service Information	Date: 4/11/2026
Profile: L180H Volvo			

11668007 Lifting tool user instructions

Showing Selected Profile

Valid for serial numbers			
Model	Production site	Serial number start	Serial number stop
L180H Volvo			



V1210648

Figure 1
11668007 lifting tool

Instructions

This instruction is a guide on how to use and maintain the lifting tool correctly. The instructions must be studied carefully by the personnel concerned before the lifting tool can be put into use.

The instructions must always be available to the personnel maintaining and using the lifting tool daily.

It is also important to:

- Keep the instructions and other applicable documents during the entire lifetime of the lifting tool.
- Pass the instructions to other owners or users of the lifting tool.
- Update the instructions with additions or changes made by the manufacturer.

Pay careful attention to information about warnings mentioned in the instructions and found on the warning signs on the lifting tools. If this information is not observed, severe personal injuries and equipment damage can arise.

Responsibility

The instructions describe the authorized method to use the lifting tool.

The lifting tool may only be used by personnel with adequate technical training or corresponding professional experience and in consultation with the manufacturer.

If the instructions have not been followed, the manufacturer is not responsible for personal injuries or damage to

equipment.

Marking

Do not remove or make machine labels or other labels unreadable.

The lifting tool is marked with a CE mark, which means that it is designed, manufactured and described in accordance with EC Machinery Directive 2006/42/EC.

Warning decals and CE mark on lifting tool must be clearly visible. If a part provided with warning decals or CE mark is changed, a new warning decal and CE mark must be mounted in the same place. Defective decals and CE marks must be replaced immediately.

Manufacturer

Company: BM Lindahl AB

Address: Älmedal 6

Postal address: 364 33 Åseda, Sweden

Rebuilding

If the lifting tool is rebuilt or supplemented with other parts without permission by the manufacturer, the CE marking does not include this part. If such rebuilding or added parts changes the function of the lifting tool, the CE marking in its entirety is no longer valid. After rebuilding, it is important that the instructions are supplemented with the necessary illustrations, photos and texts.

Intended usage

11668007 Lifting tool consists of stand, lifting jack, extensions and locking pins.

Intended users are appointed and trained personnel, the lifting tool is not intended to be used by unauthorized or underage personnel.

To fulfil the requirements for intended use, the user must follow all instructions and maintenance directions written by the manufacturer.

The lifting tool is only intended for lifting Volvo Wheel Loaders and Volvo Articulated Haulers. Maximum load: 15 000 kg (33 070 lb).

Technical data

Type designation: lifting tool

Maximum load: 15 000 kg (33 070 lb), with two 11668007 lifting tools: 30 000 kg (66 140 lbs)

Mass: 78 kg (172 lb)

Test factor for static testing: For lifting tools and manually operated machines: 1.5. For other machines: 1.25

Height: 500–800 mm (19.7–31.5 in), with extensions: 600–900 mm (23.6–35.4 in)

Safety information

Limits of use

The lifting tools may only be used for the intended purpose. All other use is forbidden.

For Volvo Wheel Loaders, the lifting tool is only intended to lift the rear axle.



V1071600

Always secured loads with safety pins. To stay under raised load without locking pins, is associated with life danger.



V1071600

To prevent breakage and sliding, the lifting tool must always be used with a vertical load.

To prevent oblique loads, always use two 11668007 lifting tools.

Handling

To meet the requirements for intended use, the user must observe all user and maintenance instructions prescribed by the manufacturer.

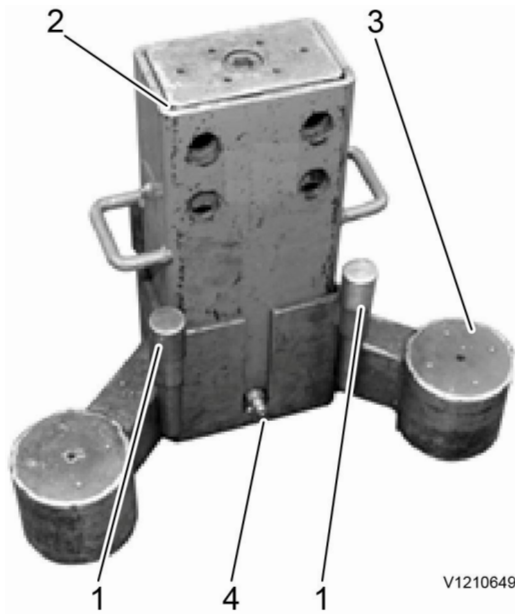

Figure 2

Pre use check

1. **Safety pins**
Make sure that safety pins are supplied along with the lifting tool.
Check that the safety pins are intact and do not have indications of breakage or deformation.
2. **Inner and outer lifting beam**
Check that the beam with pin holes is intact and do not have indications of breakage or deformation.
3. **Support legs**
The lifting tool has three support legs.
Check that the stand is intact and does not have indications of breakage or deformation.
4. **Connection nipple**
Connection nipple for pneumatic pump.

Pneumatic pump

Check that pneumatic pump with hose kit and couplings does not have indications of breakage or deformation. Always replace defective units.

Intended user

The lifting device is intended to be use by trained personnel, it is not intended to be used by unauthorized or underage personnel.

Conditions and preparatory measures

Lifting tool with damaged parts must not be used.



V1071600

Make sure that there are no people in the vicinity who may be at risk when operating this lifting tool.

Lifting



V1071600

Never stay under raised load with the safety pins disconnected.

1. **Steering linkage lock**
Lock steering linkage with steering linkage lock.
If an articulated hauler is being lifted, place body support.
Connect stops.
2. **Assemble**
Place the lifting jack into the stand.
Make sure the nipple fits in the groove.
3. **Place the lifting tool**

Place the lifting tool under wheel axle lifting point.

If needed, connect extensions.

Connect pneumatic pump to the respective nipple on the lifting tools.

To ensure a parallel lift, lower the lifting tools to their lower end point.

Start the pneumatic pump (pumps) and lift to the desired level.

4. **Safety pins**

Connect all safety pins. Make sure that all safety pins are fully inserted.

Lower until the load rests on the safety pins.



Figure 3

Lowering

1. **Steering linkage lock**

Remove steering linkage lock.

Remove stops.

2. **Remove safety pins**

Lift the load with the lifting tools to release the safety pins.

Remove all safety pins and place the safety pins at their designed holders on the lifting tools.

3. **Lower the load**

Lower the load.

Lower the lifting tools to their lower end point.

Make sure that the lifting tools are lowered parallel to avoid uneven weight distribution.

4. **Remove pump and lifting tool**

Disconnect the pneumatic pump (pumps) from the nipples on the lifting tools.

Remove the lifting tool and place it at the designated location.

Maintenance

Maintenance must be performed by person with appropriate technical training or equivalent professional experience and in consultation with the manufacturer.

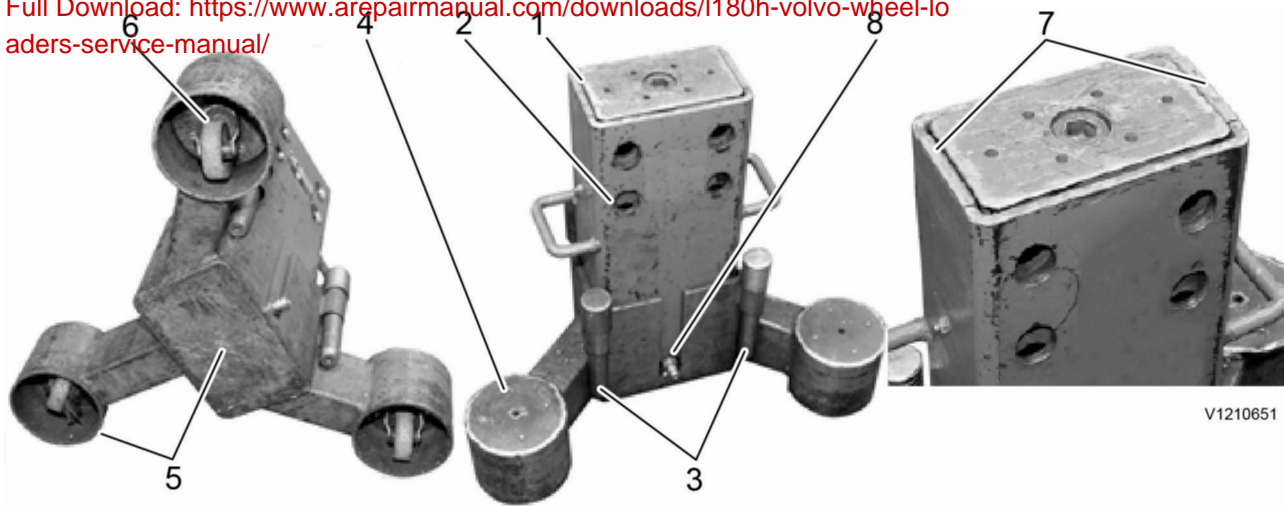

V1210651

Figure 4

Detail/interval	Control/oversight
1. Inner and outer beam Before use.	Check that beams are intact and does not have indications of breakage or deformation.
2. Pin holes, inner and outer beam Before use.	Check that all holes in beams are intact and does not have indications of breakage or deformation.
3. Pins Before use.	Check that all pins are intact and does not have indications of breakage or deformation. Before lifting, make sure that no pins are missing.
4. Support legs Before use.	Check that the support legs are intact and does not have indications of breakage or deformation.
5. Supporting surfaces Monthly check.	Check that all supporting areas are intact and does not have indications of breakage or deformation.
6. Castor As needed.	Replaced as needed.
7. Friction plate Annual check or as needed.	Lift the inner beam to its upper end point. Grease the friction plates and lower the beam to its lower end point to disperse the grease.
8. Quick coupling Before use.	Check that the quick coupling is clean. Clean dirty quick coupling with cloth. Protect quick coupling with plastic cover.

General

A defective lifting tool must be replaced.

Workplace

Protective shoes must be used.

The workplace should be kept free from equipment that can cause slipping or tripping risks.

The lifting tool is intended to be used in a workshop environment, outdoor usage is forbidden.

The lifting tool is intended to be used on a level and stable surface.

Leaked or spilled hydraulic oil should be taken care of immediately with an absorbent to prevent slipping. The supplier/ manufacturers product sheet regarding safe handling of hydraulic oil must be followed.

Continuous supervision

The lifting tool must be subjected to continuous supervision before use.

- Check for cracks.
- Check if the lifting tool is bent or deformed.
- Make sure that quick couplings are clean.

Sample manual. Download All 4970 pages at:

<https://www.arepairmanual.com/downloads/l180h-volvo-wheel-loaders-service-manual/>