

Document Title: Description	Function Group: 000	Information Type: Service Information	Date: 4/9/2026
Profile:			

Description

Both the L150 and the L180 are four-wheel drive loaders with articulated frame steering.

The engine in the L150 is a six-cylinder, four-stroke direct-injection, turbocharged diesel engine with the type designation TD102. In the L180 the engine is also a six-cylinder, four-stroke direct-injection, turbocharged diesel engine, but its type designation is TD122.

The transmission is a hydro-mechanical gearbox, where all gear wheels are in constant mesh. The transmission in the L150 has the type designation HT210 and in L180 the designation of the transmission is HT220.

A single-stage hydraulic torque converter is fitted between the engine and the transmission.

The front and rear axles have fully floating drive shafts with planetary type gears in the hubs. The front axle is provided with a differential lock.

The parking and service brakes of the machine are disc type brakes running in oil. The parking brake is positioned on the output shaft of the transmission and the service brakes are built integral with the respective planetary hub gears.

The steering system is hydrostatic with a variable load-sensing axial piston pump and two hydraulic cylinders (steering cylinders).

Hydraulic system, see [Invalid linktarget].



Figure 1
Loader L150



Figure 2
Loader L180
Sample manual. Download All 699 pages at:
<https://www.arespairmanual.com/downloads/l150c-volvo-wheel-loaders-service-manual/>

Document Title: Product Identification Plates L150	Function Group: 000	Information Type: Service Information	Date: 4/9/2026
Profile:			

Product Identification Plates L150

The illustration below shows where the different identification plates are positioned. When ordering spare parts or when making inquiries by telephone or correspondence on service matters, the type designation and the serial number should always be stated.

Where applicable, any information on the additional plate "INCL. PARTS" should also be stated.

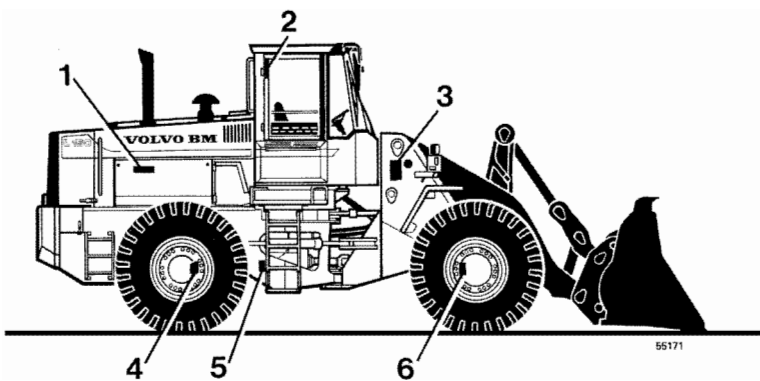

Figure 1

Product identification plates L150

1	Engine (right-hand side of machine). Engine type, product and serial numbers stamped into the cylinder block near the upper edge.
2	Cab (rear right corner post) showing type approval and serial number.
3	Product identification plate for complete machine (left side of machine) showing type designation, product and serial numbers and equipment. The type designation and serial number are also stamped into the front frame.
4	Rear axle (left side, forward) showing product and serial numbers.
5	Transmission (right side) showing product and serial numbers.
6	Front axle (right side rearward) showing product and serial numbers.

Document Title: Product Identification Plates L180	Function Group: 000	Information Type: Service Information	Date: 4/9/2026
Profile:			

Product Identification Plates L180

The illustration below shows where the different identification plates are positioned. When ordering spare parts or when making inquiries by telephone or correspondence on service matters, the type designation and the serial number should always be stated.

Where applicable, any information on the additional plate "INCL. PARTS" should also be stated.

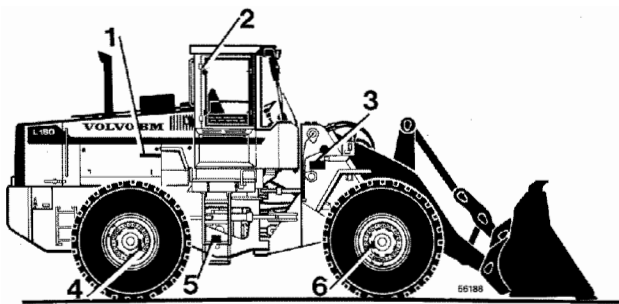

Figure 1
Product identification plates L180

1	Engine (right-hand side of machine). Engine type, product and serial numbers stamped into the cylinder block near the upper edge.
2	Cab (rear right corner post) showing type approval and serial number.
3	Product identification plate for complete machine (left side of machine) showing type designation, product and serial numbers and equipment. The type designation and serial number are also stamped into the front frame.
4	Rear axle (left side, forward) showing product and serial numbers.
5	Transmission (right side) showing product and serial numbers.
6	Front axle (right side rearward) showing product and serial numbers.

Document Title: Air conditioning (AC)	Function Group: 030	Information Type: Service Information	Date: 4/9/2026
Profile:			

Air conditioning (AC)

	L150		L180	
	kg	lb	kg	lb
AC, amount of refrigerant, R12				
L150 up to and incl. ser. no. 1482	2.1 – 2.2	4.6 – 4.9		
L180 up to and incl. ser. no. 1236			2.1 – 2.2	4.6 – 4.9
AC, amount of refrigerant, R134a				
L150 w.e.fr. ser. no. 1483	2.2 – 2.3	4.9 – 5.1		
L180 w.e.fr. ser. no. 1237	2.2 – 2.3	4.9 – 5.1		

Document Title: Capacities	Function Group: 030	Information Type: Service Information	Date: 4/9/2026
Profile:			

Capacities

	L150		L180	
	litre	US gal	litre	US gal
Engine, incl. filter, total	29	7.7	32	8.4
Engine, incl. filter, when changing oil	27	7.1	30	7.9
Cooling system, total	65	17.2	80	21.1
Fuel tank, total	339	89.5	339	89.5

	L150		L180	
	litre	US gal	litre	US gal
Front axle, total when changing oil, AH70N	43	11.4		
Front axle, total when changing oil, AWB40	55	14.5	55	14.5
Rear axle, total when changing oil, AH65A	43	11.4		
Rear axle, total when changing oil, AWB40	54	14.3	54	14.3
Transmission + torque converter incl. filter, total	45	11.9	48	12.7
Transmission + torque converter incl. filter, when changing	35	9.2	35	9.2

	L150		L180	
	litre	US gal	litre	US gal
Hydraulic oil tank	165	44	165	44
Hydraulic system (brakes, steering, working hydraulics) total	245	65	260	69
Hydraulic system (brakes, steering, working hydraulics) when changing	165	44	165	44

Document Title: Volvo BM standard tightening torques	Function Group: 030	Information Type: Service Information	Date: 4/9/2026
Profile:			

Volvo BM standard tightening torques

The tightening torques in the following tables apply to bolts with a tensile strength as shown below. The tables are to be considered as a general instruction for the tightening torque of nuts and bolts when no other torque is stated.

NOTE!

For flanged bolts type U6FS the values should be increased by 10 %.

Nut and bolts should be cleaned and lubricated with oil.

TENSILE STRENGTH 8.8

Metric coarse and fine threads

Thread	Nm	kgf.m	lb.ft
M6	10±2	1,0±0,2	7,4±1,5
M8	24±5	2,4±0,5	18±3,5
M10	48±10	4,8±1,0	35±7,4
M12	85±18	8,5±1,8	63±13,0
M14	140±25	14,0±2,5	103±18,0
M16	220±45	22,0±4,5	160±33,0
M20	430±85	43,0±8,5	320±63,0
M24	740±150	74,0±15,0	550±110,0

TENSILE STRENGTH 10.9

Metric coarse and fine threads

Thread	Nm	kgf.m	lb.ft
M6	12±2	1,2±0,2	9±1,5
M8	30±5	3,0±0,5	22±3,5
M10	60±10	6,0±1,0	44±7,5
M12	105±20	10,5±2,0	78±14,5
M14	175±30	17,5±3,0	130±22
M16	275±45	27,5±4,5	204±33
M20	540±90	54,0±9,0	400±66
M24	805±160	80,5±16,0	594±118

UNC threads

Thread	Nm	kgf.m	lb.ft
1/4"	9±2	0,9±0,2	6,6±1,5
5/16"	18±4	1,8±0,4	13±3,0
3/8"	33±8	3,3±0,8	24±5,9
7/16"	54±14	5,4±1,4	40±10
1/2"	80±20	8,0±2,0	59±15
9/16"	120±30	12,0±3,0	89±22

5/8"	170±40	17,0±4,0	130±30
3/4"	300±70	30,0±7,0	220±52
7/8"	485±115	48,5±11,5	360±85
1"	725±175	72,5±17,5	530±130

Document Title: Weights (approx.)	Function Group: 030	Information Type: Service Information	Date: 4/9/2026
Profile:			

Weights (approx.)

	L150		L180	
	kg	lb	kg	lb
Engine, standard	990	2183	1170	2580
Engine, low emission	1020	2249	1180	2602
Guard plate for fuel tank	100	221	100	221

	L150		L180	
	kg	lb	kg	lb
Transmission	855	1885	855	1885
Front axle AH70	1635	3605	–	
Rear axle AH65 incl. rear axle mounting	1770	3903	–	
Front axle AWB40	1250	2756	1250	2756
Rear axle AWB40 incl. rear axle mounting	1570	3462	1570	3462
Front mounting, rear axle L150 up to and incl. ser. no. 1233	120	265		
L150 w.e.fr. ser. no. 1234	110	243	110	243
Rear mounting, rear axle L150 up to and incl. ser. no. 1233	130	287		
L150 w.e.fr. ser. no. 1234	135	298	135	298

	L150		L180	
	kg	lb	kg	lb
Cab	690	1521	690	1521
Counterweight	1550	3417	3155	6957

	L150		L180	
	kg	lb	kg	lb
Hydraulic oil pump, working hydraulics	32.5	72	71	157
Control valve	60	132	60	132
Lifting frame, incl. links, pins and cylinders	2380	5248	2570	5667
Lifting cylinder	205	452	215	474

Tilting cylinder	355	783	380	838
------------------	-----	-----	-----	-----

Document Title: Time Guide	Function Group: 070	Information Type: Service Information	Date: 4/9/2026
Profile:			

Time Guide

Regarding: L150C

16 Lubricants, fuels and other liquids

Op.no.	Time (h)	Operation
16234	1,75	Hydraulic oil tank, changing oil and filter excl. cleaning tank
16236	2,5	Hydraulic oil tank, changing oil and filter incl. cleaning tank
16238	1,5	Transmission, changing oil and filter and cleaning suction strainer
16259	2	Axles, changing oil

17 General

17101	0,5	Arrival inspection, according to programme
17102	4	Delivery inspection, according to programme
17202	3,5	Warranty inspection 100 hours, according to service programme
17204	8	Warranty inspection 1000 hours, according to service programme
17307	1,5	Maintenance service, every 250 hours
17310	3	Maintenance service, every 500 hours
17312	5,5	Maintenance service, every 1000 hours
17314	8	Maintenance service, every 2000 hours

21 Engine, general

21002	1,75	Compression test, engine at operating temperature
21070	8	Engine, removing
21071	40	Engine removed, general overhaul
21072	9	Engine, fitting
21102	7	Cylinder head, replacing gasket
21118	12	Cylinder heads all, replacing gaskets
21168	4	Cylinder heads all removed, decarbonizing and grinding in valves
21171	0,5	Cylinder head removed, pressure testing each
21207	4	Cylinder block, liners removed, milling of all liner locations
21211	0,5	Cylinder, cylinder heads removed, measuring wear in all cylinders

21310	16	Cylinder liner and piston, replacing one
21318	24	Cylinder liners and pistons, replacing all
21412	1,5	Valves, adjusting
21427	0,5	Inspection cover, fitting new gasket
21430	16	Valves, decarbonizing and grinding
21436	1	Valve covers all, fitting new gasket
21502	5	Timing gear cover, fitting new gasket in machine
21530	6	Timing gear, replacing in machine
21532	7	Timing gear case, fitting new gasket in machine
21614	2,5	Crankshaft, replacing front oil seal
21618	18	Crankshaft, replacing rear oil seal
21702	6,5	Sump gasket, replacing incl cleaning oil strainer

22 Lubrication and oil system

22106	1	Oil pressure relief valve, replacing
22114	7	Oil pump, replacing
22306	2	Oil cooler, replacing

23 Fuel system, general

23301	0,5	Fuel system, bleeding
23302	0,75	Feed pump, replacing
23304	0,5	Feed pump, checking feed pressure
23314	0,5	Fuel filters all, replacing
23397	0,25	Feed pump removed, reconditioning
23410	4	Fuel tank, replacing
23601	0,5	Idling speed, checking and adjusting
23602	0,25	Stall speed, checking
23630	1,5	Injection timing, checking and adjusting
23644	1	Injection timing, checking
23673	3	Injection pump, replacing incl setting injection timing
23702	2	Injectors, replacing all
23704	0,75	Injector, replacing one
23707	0,25	Overflow valve, replacing
23716	1,5	Injectors, replacing copper sleeve in machine
23718	0,75	Delivery pipe, replacing one
23780	2	Injectors removed, reconditioning all

25 Inlet and exhaust systems

25102	1	Induction manifold, replacing gasket
25104	2	Exhaust manifold, replacing gasket
25220	1,5	Silencer, replacing
25221	0,75	Exhaust pipe, flexible tube, replacing
25571	1,5	Turbo charger, replacing

25573	2	Turbo charger removed, reconditioning
25601	0,5	Air cleaner, cleaning filter element
25602	0,25	Air cleaner, checking prssure drop indicator
25603	0,25	Air cleaner, primary filter replacing
25604	0,25	Air cleaner, secondary filter replacing
25606	0,75	Pre-heating coil, replacing

26 Cooling system

26104	1	Coolant, changing
26108	3	Radiator, replacing
26112	1	Radiator hose upper, replacing
26114	1,5	Radiator hoses lower, replacing
26202	1,5	Coolant pump, replacing
26271	1,5	Coolant pump removed, reconditioning
26298	1	Thermostat, replacing
26312	0,75	Fan belt and/or alternator belt, replacing
26322	1	Fan belt and/or alternator-, compressor belt, replacing all belts

27 Engine control

27321	0,75	Stop magnet, replacing
27323	0,5	Electrical engine shut down, check and adjusting

31 Battery and mounting parts

31101	0,5	Batteries, checking charging capacity
31102	1	Batteries, replacing
31103	0,5	Main switch, replacing

32 Alternator and charge regulator

32102	1	Alternator, replacing incl function check (no measuring instrument)
32125	0,5	Alternator, replacing carbon brush kit in machine
32205	0,5	Charging regulator, replacing

33 Starting system, general

33118	1	Starter motor, replacing
33401	0,5	Starter lock, replacing

35 Lighting

35202	0,5	Headlights, adjusting against wall or screen
35224	0,5	Head lamp assy, replacing one incl adjusting
35316	0,5	Rear lamp, replacing one

35318	0,25	Rear lamp, replacing glass or bulb
35656	0,5	Work lighting, replacing one head lamp assy
35657	0,5	Work lighting, replacing one insert

36 Other electrical equipment, general

36102	0,25	Flasher unit, replacing relay
36110	0,75	Flasher switch, replacing
36117	0,25	Flasher lamp, replacing glass or bulb
36202	0,25	Horn, replacing
36203	0,5	Reverse alarm, replacing
36216	0,75	Horn switch, replacing
36301	0,5	Windscreen wiper rear, replacing motor
36302	0,75	Windscreen wiper front, replacing motor
36303	0,75	Windscreen wiper, replacing switch
36304	0,25	Windscreen flusher pump, replacing
36404	0,25	Switch, replacing
36408	0,25	Brake light switch, replacing
36720	0,5	ECU, replacing
36721	0,5	CU 8, replacing

38 Instruments, sender units, warning systems

38603	1,5	Transmission oil pressure sensor, replacing
38604	0,5	Transmission temperature sensor, replacing
38605	0,5	Transmission, revolution sensor, replacing
38606	0,5	Engine temperature sensor, replacing
38607	0,5	Engine oil pressure sensor, replacing
38611	0,75	Fuel level sender, replacing
38704	0,5	Transmission temperature gauge, replacing
38705	0,5	Information display, replacing
38706	0,5	Engine temperature gauge, replacing
38711	0,5	Fuel level gauge, replacing
38720	0,5	Tachometer, replacing

39 Other equipment, e.g. radio and voltage conv.

39301	0,5	Voltage converter, replacing
-------	-----	------------------------------

42 Transmission, general

42102	0,75	Hydraulic transmission, check oil pressure
42106	1	Oil cooler, replacing
42108	2	Gear selector valve, replacing
42109	1,75	Gear selector valve removed, reconditioning

42118	18	Converter, replacing
42124	2	Lubrication oil valve, replacing
42147	0,75	Gear selector, replacing
42148	0,75	Gear selector valve, replacing one solenoid
42152	3	Seal for front output shaft, replacing
42154	3	Seal for rear output shaft, replacing
42170	10	Transmission, removing
42171	32	Transmission removed, reconditioning
42172	11	Transmission, fitting

45 Propeller shaft incl. bearings and mounting

45101	0,25	Propeller shaft and intermediate bearing, checking radial clearance
45102	2	Support or intermediate bearing, replacing
45104	1,5	Propeller shaft, rear, replacing
45107	1,5	Propeller shaft, in frame joint, replacing
45110	2	Propeller shaft, front, replacing
45113	1,5	Propeller shaft, removed reconditioning

46 Drive axles, general

461	Null	Front axle
46101	7	Axle, replacing
46111	10	Centre gear , removing and fitting
46112	10	Centre gear removed, reconditioning
46113	13	Centre gear, axle removed, reconditioning
46114	1,5	Pinion front, fitting new gasket
46118	1,5	Oil cooler, replacing
46119	2	Oil pump, replacing
46140	3	Hub retainer, replacing
46141	6,5	Hub retainer removed, reconditioning
46143	4,5	Hub, replacing seal
46152	0,25	Differential lock front, repacking excl adjusting
46153	0,75	Differential lock, adjusting engagement
463	Null	Rear axle
46301	8	Axle, replacing
46302	4,5	Axle, removing
46303	4,5	Axle, fitting
46311	11	Centre gear, removing and fitting
46312	10	Centre gear removed, reconditioning
46313	13	Centre gear, axle removed, reconditioning
46314	1,5	Pinion rear, fitting new gasket
46318	1,5	Oil cooler, replacing
46319	2	Oil pump, replacing
46340	3	Hub retainer, replacing

46341	6,5	Hub retainer removed, reconditioning
46343	4,5	Hub, replacing seal

51 Wheel brake, all

516	Null	Front axle
51601	0,5	Brake linings, checking wear
51604	4,5	Brake discs, replacing on both sides
51650	3,5	Brake piston, replacing seals
517	Null	Rear axle
51701	0,5	Brake linings, checking wear
51704	5	Brake disc, replacing both sides
51750	4	Brake piston, replacing seals

52 Hydraulic brake system

52001	0,5	Brake system, checking function, hydraulic
52002	0,5	Brake system, checking function, retardation
52004	0,5	Brake system, adjusting unloading pressure
52005	0,5	Brake system, check and adjusting pressure in circuit
52037	1	Brake system, bleeding
52508	2	Foot brake valve, replacing
52509	1,25	Foot brake valve removed, reconditioning
52701	0,5	Accumulator removed, checking charging pressure
52702	0,5	Accumulator, replacing
52704	2,5	Hydraulic pump, replacing

55 Parking brake incl.control system

55006	3,5	Parking brake, replacing discs and seals
55008	1	Parking brake, replacing control valve

64 Steering

64121	1,5	Adjustable steering column, replacing
64506	1,75	Steering cylinder, replacing
64510	6	Hydraulic pump, replacing
64515	0,5	Steering system, checking and adjusting standby pressure
64520	2,5	Steering system, checking and adjusting shock and anti-cavitation-
64521	1,5	Valve block, replacing
64528	0,75	Steering system, checking and adjusting working pressure
64554	2	Steering cylinder, replacing link bearings
64560	2,5	Steering cylinder, repacking in machine

64573	2,5	Hydraulic pump removed ,reconditioning
64577	1,75	Steering cylinder removed, reconditioning incl replacing bearings
64579	2,5	Shift valve, replacing
64581	1,5	Steering valve removed, reconditioning
64582	2	Steering valve, replacing
64793	1	Auxiliary steering, replacing hydraulic pump

74 Frame joint, general

74105	0,5	Frame joint, checking clearance
74136	17	Frame joint, replacing bearings

75 Axle suspension, general

75501	0,75	Axle suspension, measuring axial and radial clearanse
75502	1	Axle suspension, adjusting axial clearance
75503	13	Axle suspension, replacing bushes and seals

77 Wheel, Tyre, Hub, Crawler/Track

77101	0,75	Wheel, removing and fitting
-------	------	-----------------------------

81 Cab, general

81815	1,75	Cab suspension, rubber element replacing
-------	------	--

83 Doors and Covers

83104	1,75	Door, replacing
83106	0,75	Door lock, replacing
83114	0,5	Door, replacing sealing strip

84 Outside trim parts, Glass, Sealing, Mouldings

84302	5	Windscreen, replacing
84312	1	Rear window, replacing
84313	1	Side windov, replacing
84348	1	Door window, replacing

87 Air Conditioning unit

87201	0,25	Cab filter, replacing
87304	1	Radiator, replacing
87306	1	Fan motor, replacing
87308	0,75	Heat control valve, replacing
87309	0,75	Heat control, replacing
87402	1	Refrigerant, draining

87403	0,75	Cooling unit, performance test
87405	1	Refrigerant, filling excl vacuum pumping
87406	4	Compressor, replacing incl draining and filling
87407	0,5	V-belt, replacing
87410	4	Condenser, replacing incl draining and filling
87411	3	Receiver, replacing incl draining and filling
87412	4	Evaporator, replacing incl draining and filling
87413	3,5	Expansion valve, replacing incl draining and filling
87414	0,75	Thermostat, replacing
87415	1,5	Compressor, replacing shaft seal (compressor removed)
87416	0,75	Compressor, replacing magnetic clutch (compressor removed)
87417	0,75	Compressor, replacing magnetic clutch in machine
87419	0,5	Compressor, replacing valve plate (compressor removed)
87420	4	Condenser, replacing incl draining and filling

91 Working hydraulic and servo system

91101	0,5	Oil return filter, replacing incl cleaning magnetic core
91105	2	Hydraulic tank, replacing inlet hose for pump
91111	1	Oil cooler, replacing
91138	5	Hydraulic oil tank, replacing
91201	5	Control valve, replacing
91202	4	Control valve removed, reconditioning
91204	0,75	Control valve, low pressure valve, replacing
91209	0,5	Shock valve, tilt function, checking and adjusting
91210	1	Shock valve, lowering function, checking and adjusting
91211	0,75	Shock valve lift function, adjusting
91304	0,5	Oil pump, checking and adjusting working pressure
91310	3	Oil pump, replacing
91311	1,75	Oil pump removed, reconditioning
91312	3,5	Oil pump, replacing cartridge
91313	3,5	Oil pump, replacing seal for input shaft
91454	1,75	Servo valve, adjusting control
91455	1	Servo pressure, checking and adjusting
91457	0,5	Servo pressure, check
91458	3	Servo valve, replacing

91460	2,5	Servo pump, replacing
91462	0,5	Pressure limiting valve, replacing
91463	1,75	Servo pressure, checking by spool valve in control valve
91475	2	Servo valve removed, reconditioning
91601	0,5	Boom suspension system, checking function
91602	1,75	Accumulator, check and adjusting
91603	1	Accumulator, reconditioning
91604	1,5	Boom suspension system, checking closing pressure
91605	1	Boom suspension system, checking opening pressure

94 Unit for load handling

94502	4,5	Lift frame, replacing bearing in lower bucket- or implement attachment
94503	0,5	Implement attachment, measuring clearance of lower bearing
94504	4	Lift cylinder, replacing
94505	5,5	Lift cylinder, repacking in machine
94506	3	Lift cylinder removed, repacking
94507	0,75	Tilt cylinder removed, replacing bearings "E-F"
94508	5	Tilt cylinder, replacing
94509	8	Tilt cylinder, repacking in machine
94510	4	Tilt cylinder removed, repacking
94512	1	Lift cylinder removed, replacing bearings "C-P"
94516	6	Lift frame, replacing bearing in upper mounting "O"
94524	4	Tilt cylinder, replacing bearing in machine "E-F"
94554	3	Implement attachment, replacing
94562	2	T-link upper, replacing "HIJ"
94563	0,75	T-link upper removed, replacing bearings "HIJ"
94564	3	T-link, lower, replacing "IB"
94565	2	T-link lower removed, replacing bearing "IB"
94566	2	Tilt link, replacing "GH"
94567	0,75	Tilt link removed, replacing bearings "GH"
94568	3,5	Tilt arm, replacing bearing "GDF"
94569	4	Tilt arm, replacing "GDF"
94570	1,75	Tilt arm removed, replacing bearing "GDF"

99 Miscellaneous

99905	2,5	Loadtronic, replacing sensor
-------	-----	------------------------------

Document Title: E-tools	Function Group: 080	Information Type: Service Information	Date: 4/9/2026
Profile:			

E-tools

Drawings of tools (E-tools) which can be made in your own workshop

The measurements of the drawings are given in mm, unless otherwise stated (1 mm 0.03937 in).

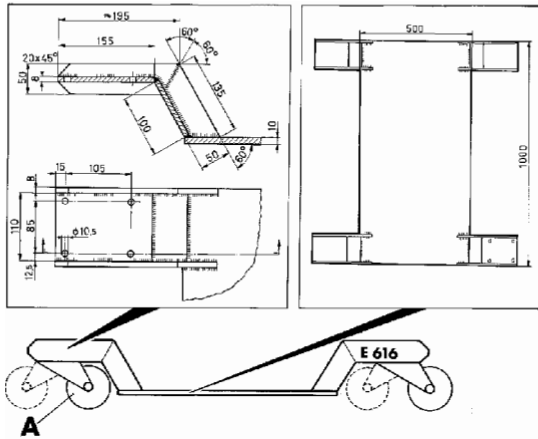

Figure 1
E 616 TROLLEY

A	Castor, 4 pcs (Haco 4HL)
---	--------------------------

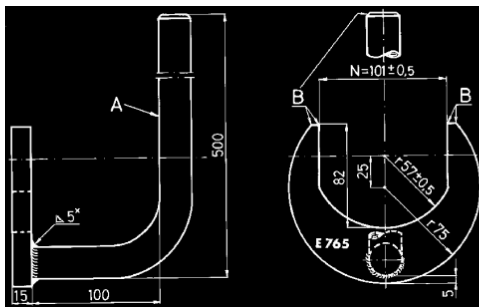

Figure 2
E 765 SPANNER

A	Pipe, 3/4"
B	Chamfered
N	Width across flats
*	To be welded electrically

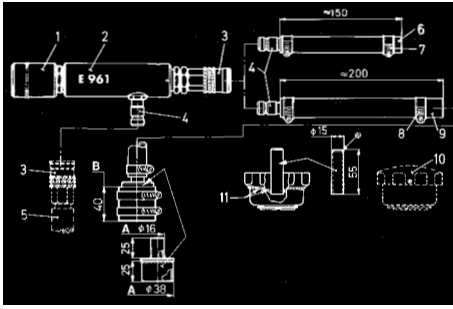

Figure 3
E961 EJECTOR

A	Pipe
B	Hose, ϕ 38 mm
1	Silencer no. 3216002 (3/4") PV 100 [1]
2	Ejector 100 no. 3106009
3	Quick-action coupling, female part
4	Quick-action coupling, male part (adapted according to the system in the workshop)
5	The workshop compressed-air system
6	Rubber hose, ϕ 1/2"
7	Clamp, part no. 943471, 2 pcs
8	Clamp, part no. 943472, 2 pcs
9	Rubber hose, ϕ 5/8"
10	Blank, part no. 739846
11	To be hard soldered

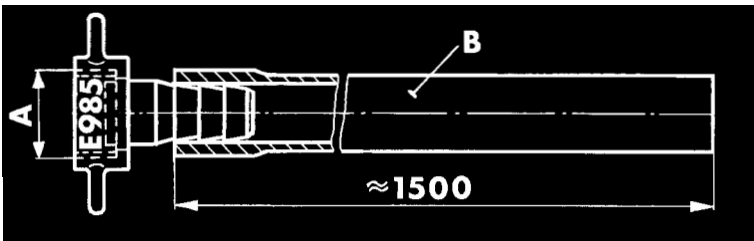

Figure 4
E 985 HOSE

A	Hose coupling, ϕ 1/2" BSP
B	PVC-hose, 1/2"

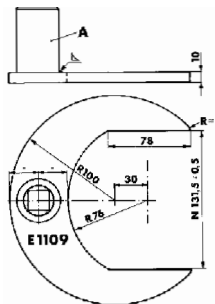

Figure 5
E 1109 SPANNER

A	Socket 3/4"
---	-------------

NOTE: Accurate gas cutting

All edges to be chamfered

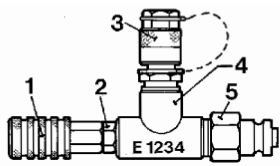

Figure 6
E 1234 NIPPLE

1	999 3522-3
2	Standard pipe bushing, 1/4" BSP - 1/8" BSP
3	Measuring nipple, part no. 930032
4	Standard T-pipe, 1/4" BSP
5	Nipple according to available pump for instance 999 3070B

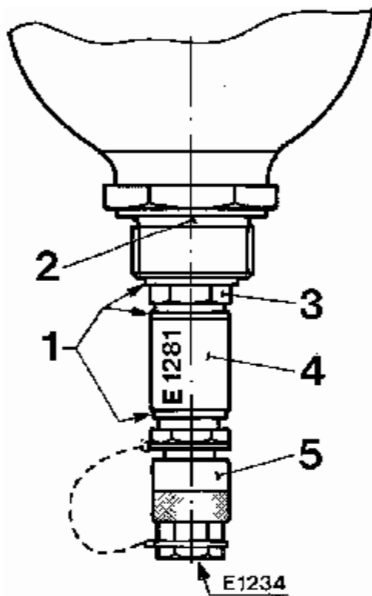

Figure 7
E 1281 NIPPLE

1	Sealing washer
2	Accumulator with thread, M16 x 1.5 internal
3	Nipple, part no. 957030
4	Socket, standard BSP 1/4"
5	Measuring nipple part no. 930032

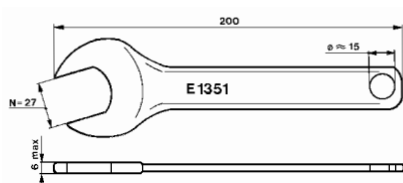

Figure 8
E1351 SPANNER

Blank:	Standard open end spanner
--------	---------------------------

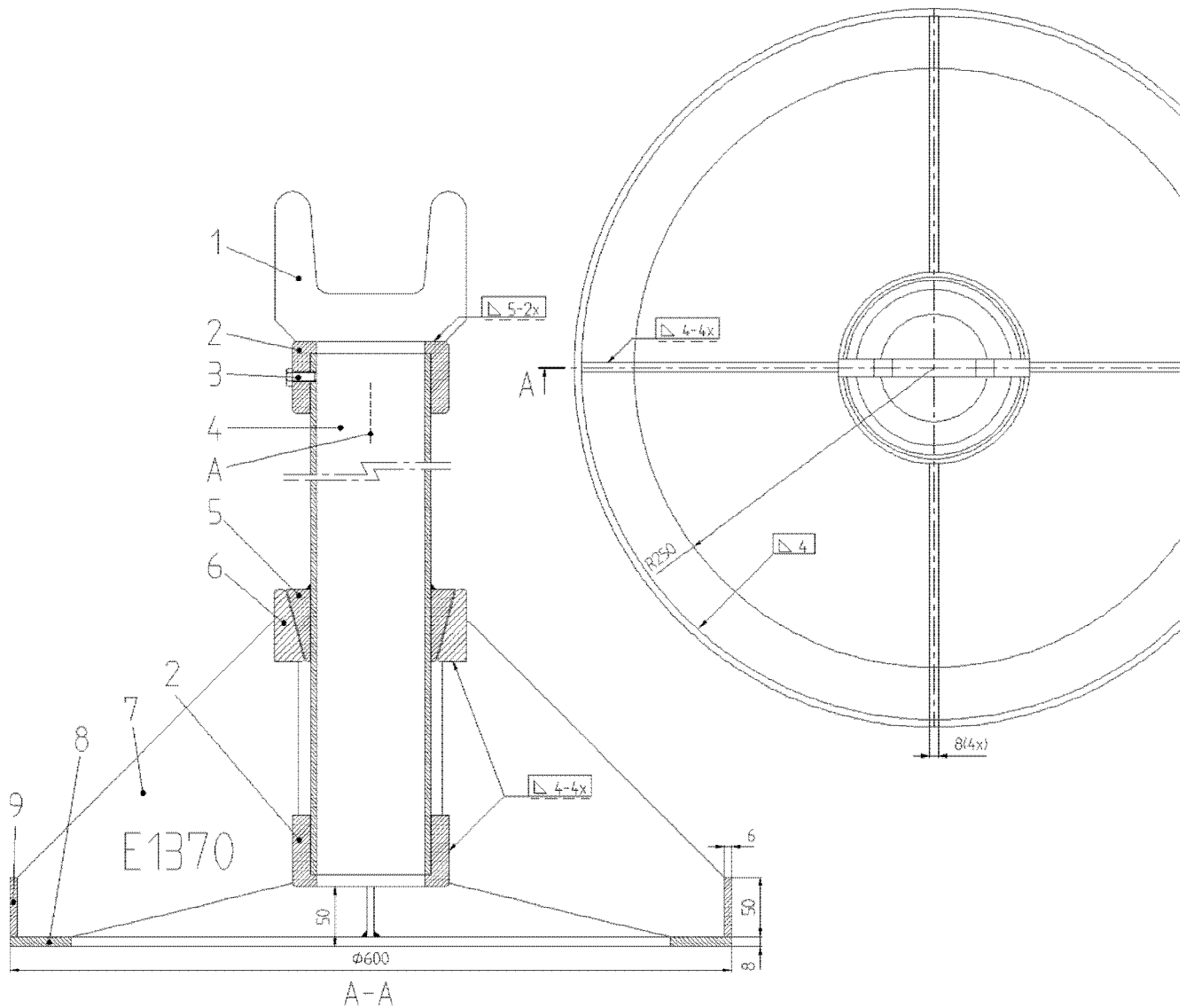

Figure 9
E 1370 SUPPORT

A	Paint: Max. load 22.5 tonnes
	E 1370 and the manufacturer's name
1	1370-1 Material, plate SIS 2172
2	1370-2 Material, SIS 2172
3	Bolt M8 x 20
4	Pipe, DIN 2391 – St35 Ø 100 x 5.0 L= 2250
5	1370-5 Material, SIS 2172
6	1370-6 Material, SIS 2172
7	1370-7 Material SIS 2172
8	Material, SIS 2172
9	Blank, Material, SIS 2172 L= 1866

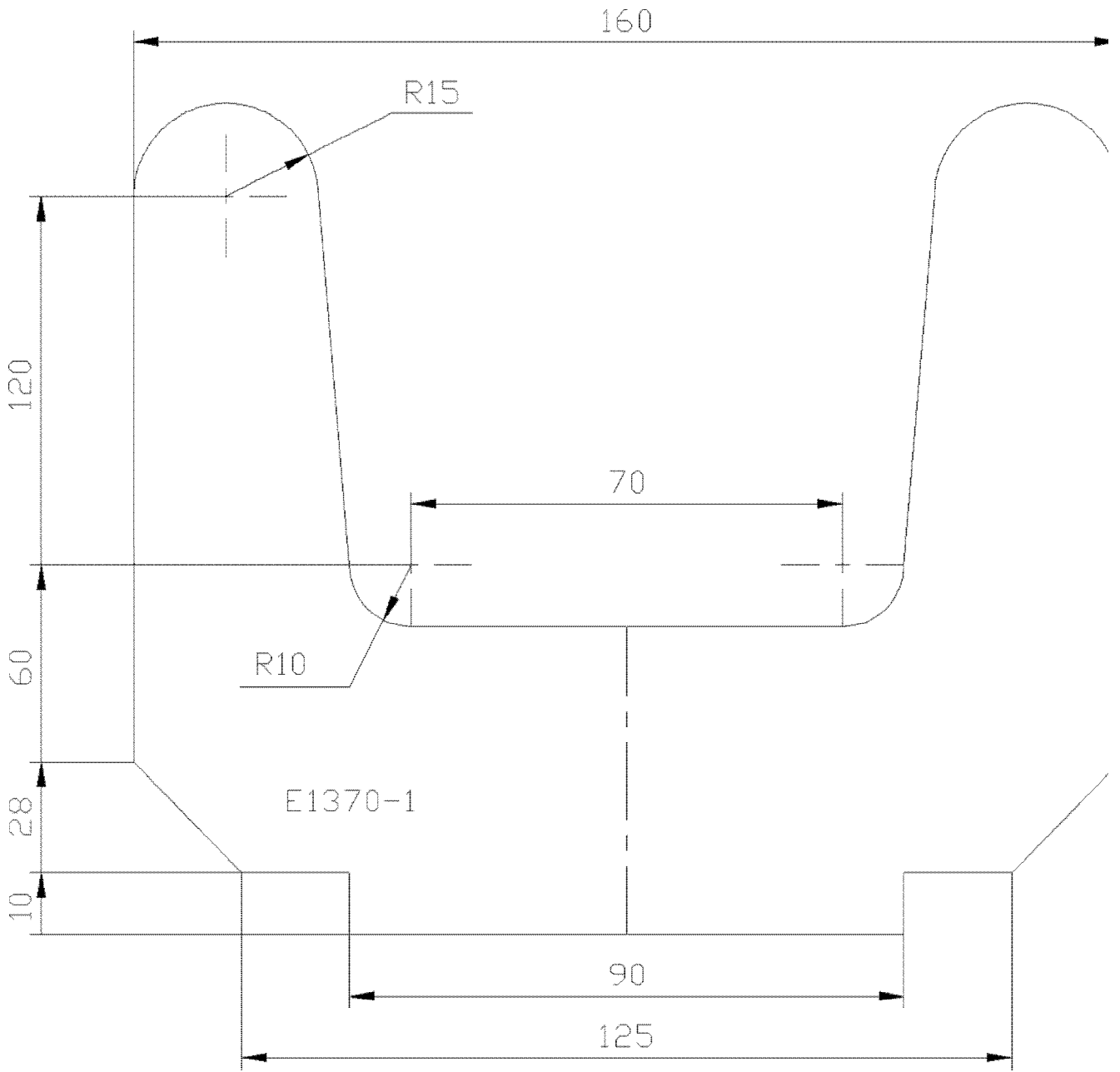

Figure 10
E 1370 – 1 SUPPORT

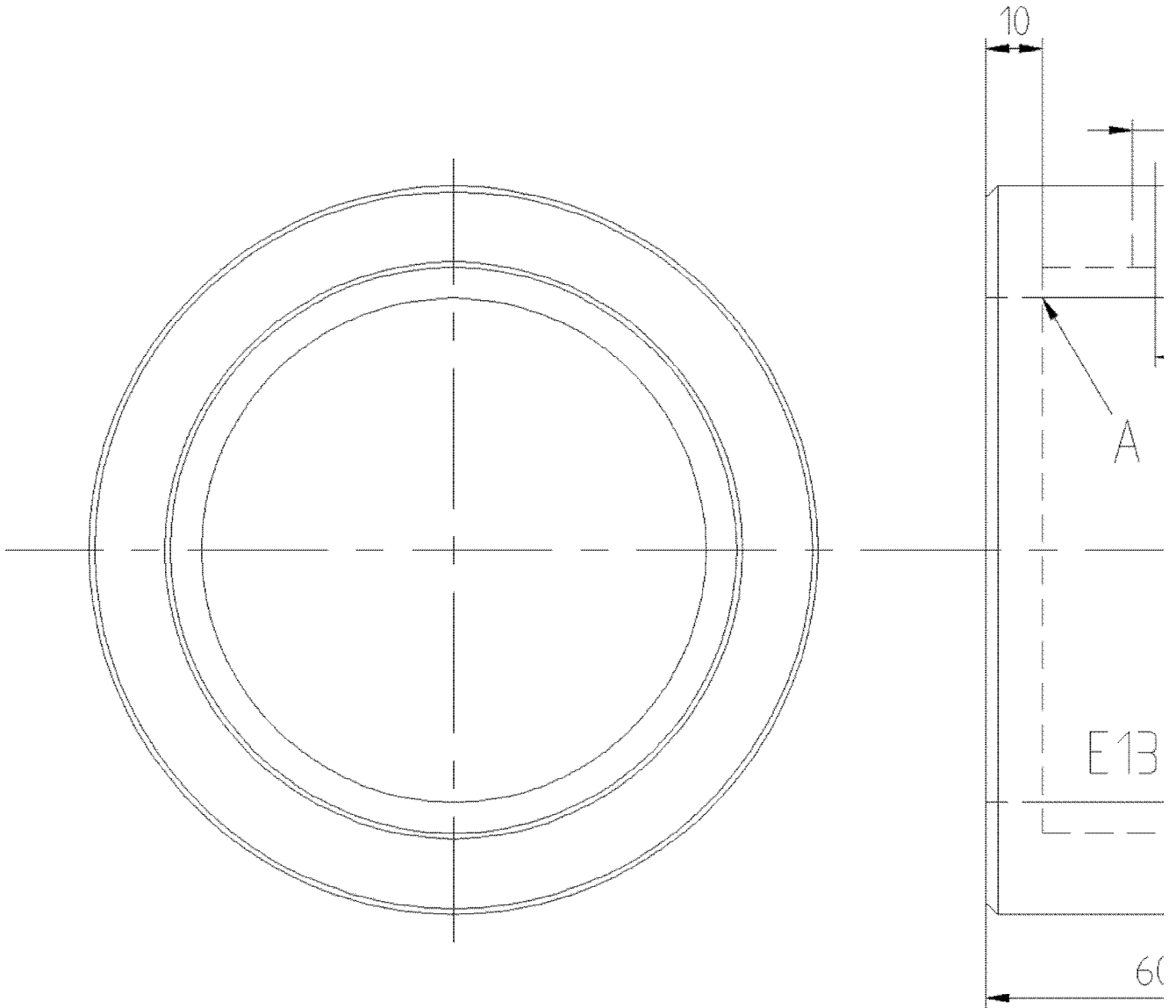

Figure 11
E 1370 – 2 SUPPORT

A	To be chamfered
---	-----------------

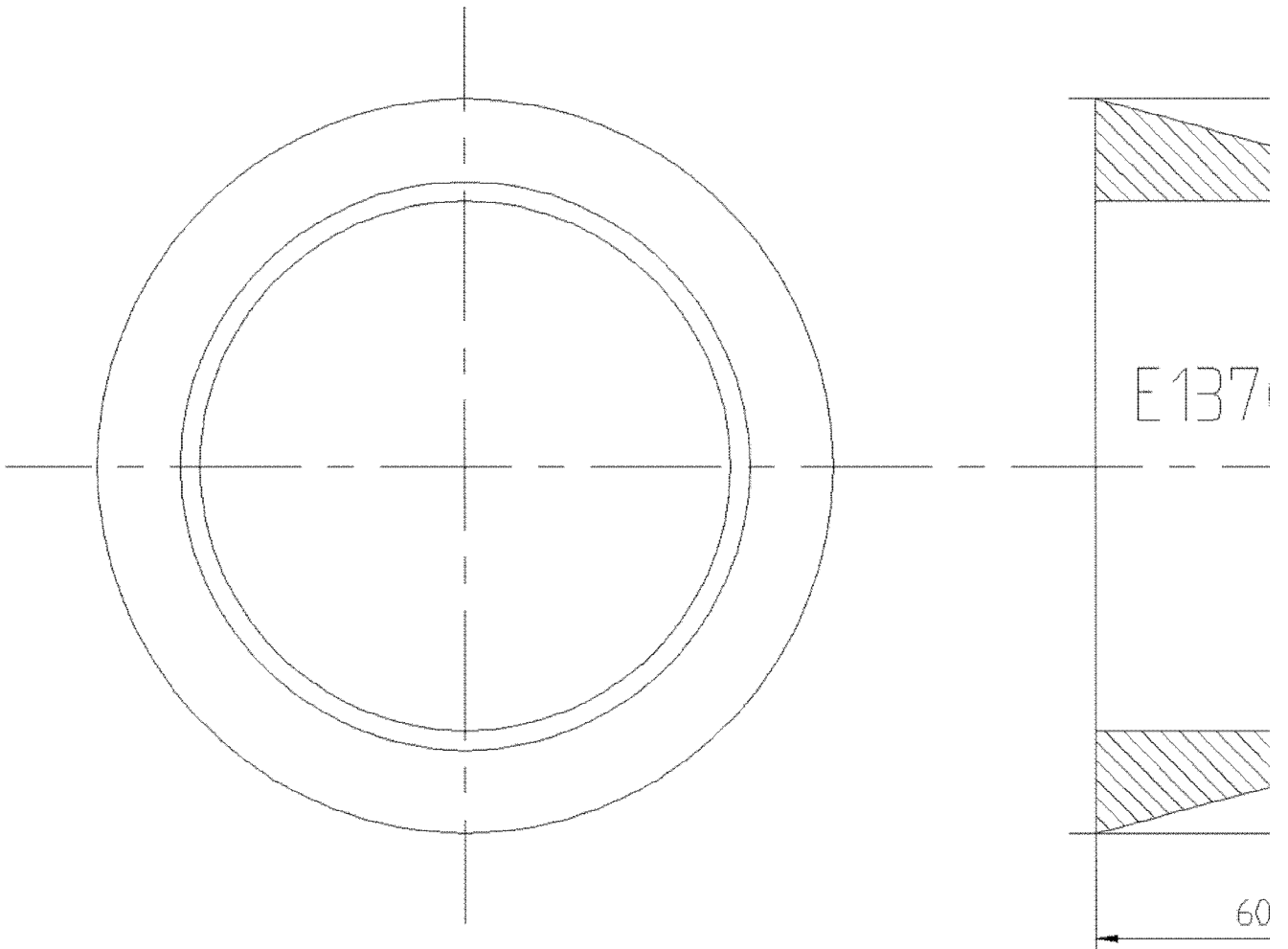

Figure 12
E 1370 – 5 SUPPORT

Material: SIS 2172

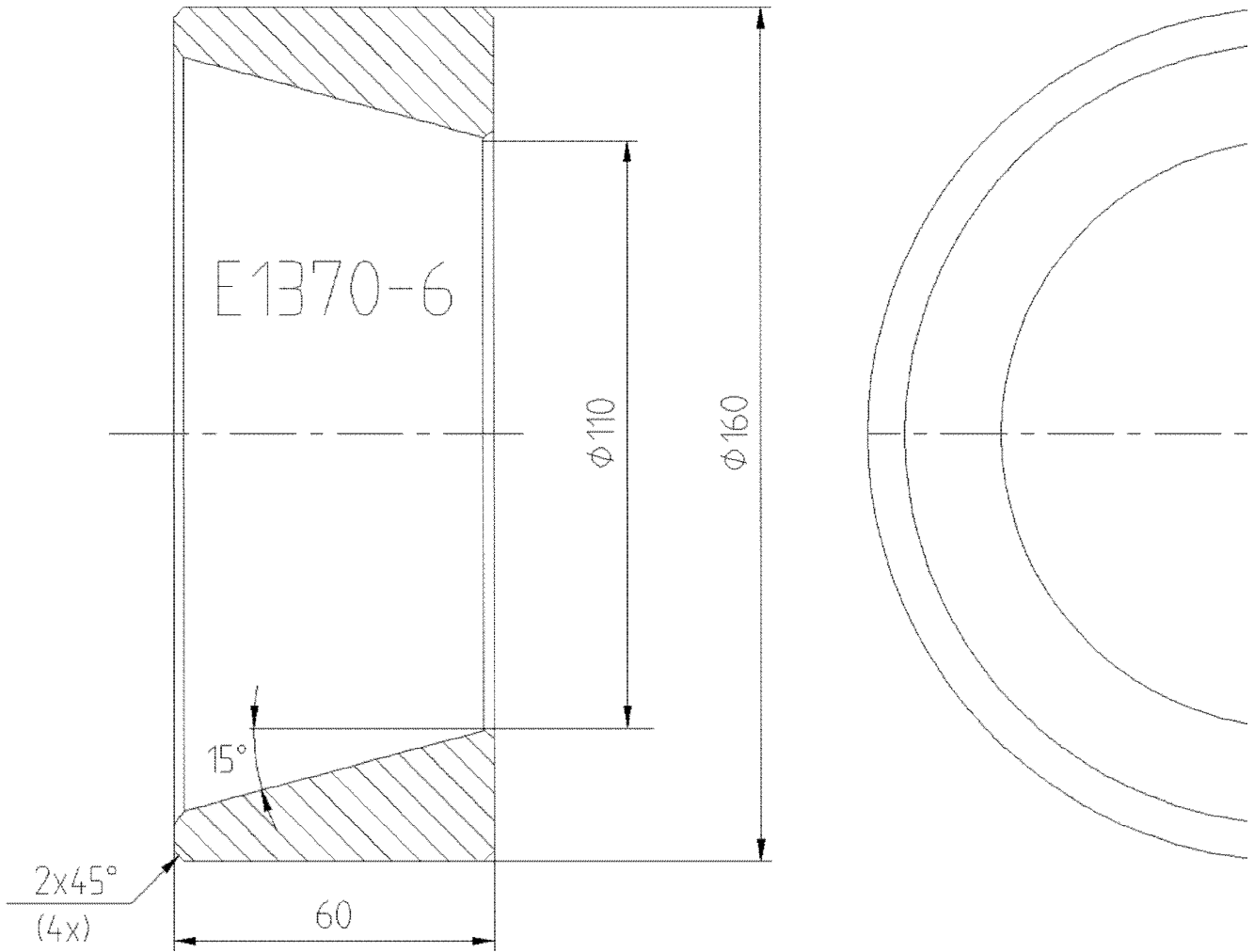

Figure 13
E 1370 – 6 SUPPORT

Material: Plate, SIS 2172

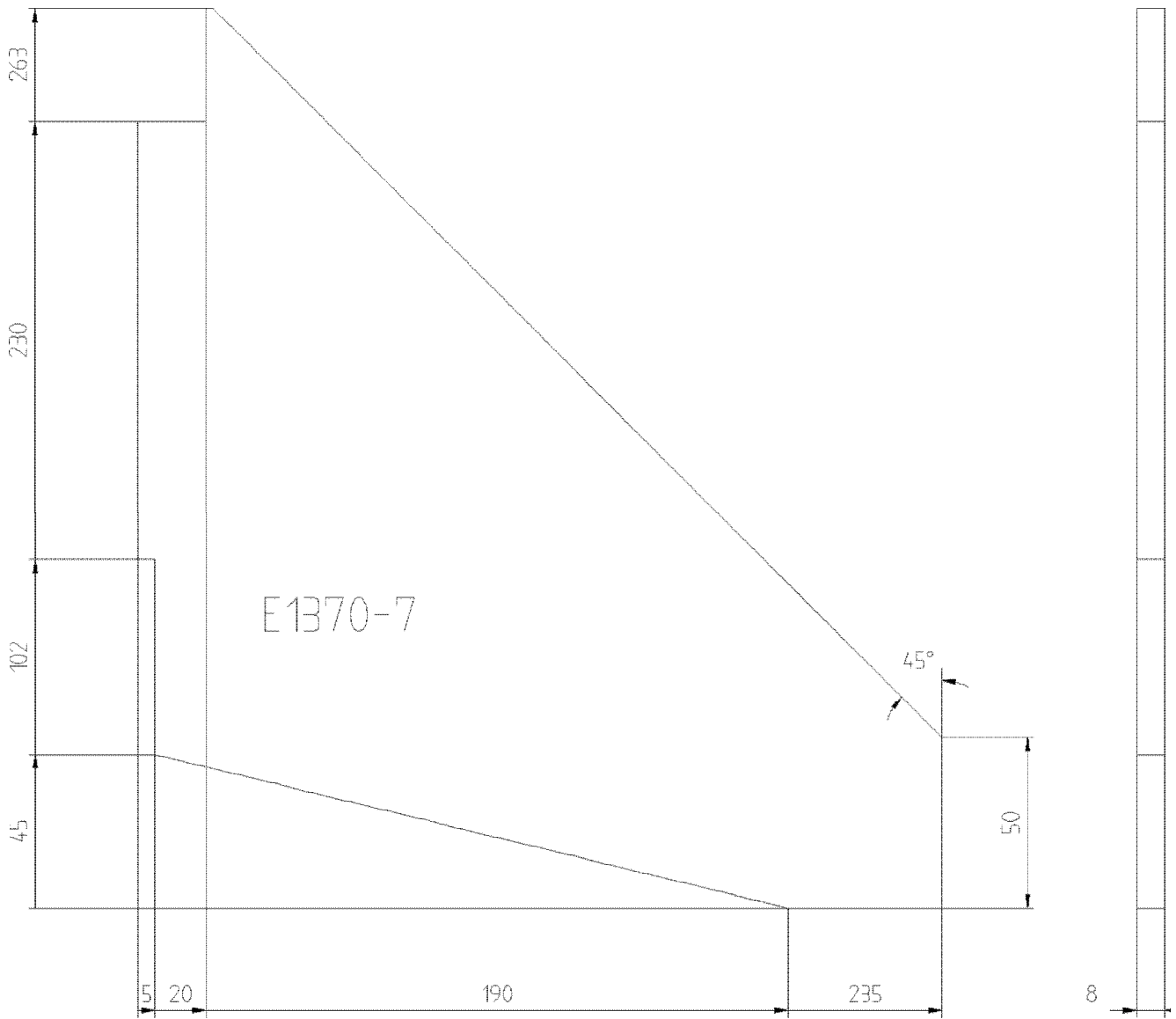

Figure 14
E 1370 – 7 SUPPORT

Material: Plate, SIS 2172

[1]PIAB AB
Stationsvägen 16
Box 123
184 Åkersberga
Phone: 0764-64050
Telex: 11508 PIAB S
Fax: 0764-63030

Document Title: Charging batteries	Function Group: 170	Information Type: Service Information	Date: 4/9/2026
Profile:			

Charging batteries

Risk of explosion

When charging, the battery gives off hydrogen gas, which, when mixed with air, will cause an explosion if ignited. Short-circuiting, an open flame or spark close to the battery can cause a powerful explosion. Always turn off the charging current before the lead clips are disconnected from the battery. Keep the place where the battery is being charged well ventilated, especially if it is a small enclosed area.

Corrosive sulphuric acid

The battery electrolyte contains corrosive sulphuric acid. If you spill electrolyte on your skin, wash immediately with soap and plenty of water. If electrolyte gets into the eyes or comes into contact with any other sensitive part of the body, rinse with plenty of water and contact a doctor immediately.

Document Title: Cleanliness when working on brake and hydraulic systems	Function Group: 170	Information Type: Service Information	Date: 4/9/2026
Profile:			

Cleanliness when working on brake and hydraulic systems

In all work on these systems, the greatest possible cleanliness must be exercised. Wipe off all pipe and hose connections before they are disconnected and remove any flakes of paint etc. Plug all pipes, hoses, cylinders etc. as soon as the connections have been laid open. Never fit an hydraulic hose which has not been sealed with plugs until it has been thoroughly cleaned.

Product: L150C Volvo Wheel Loaders Service Manual

Full Download: <https://www.arepairmanual.com/downloads/l150c-volvo-wheel-loaders-service-manual/>

V O L V O

Service Information

Document Title: Electric welding	Function Group: 170	Information Type: Service Information	Date: 4/9/2026
Profile:			

Electric welding

Before carrying out electric welding on the machine or attachments connected to the machine, the battery disconnect switch must be turned off or the battery earth lead disconnected.

Connect the welding unit as close as possible to the point of welding.

Sample manual. Download All 699 pages at:

<https://www.arepairmanual.com/downloads/l150c-volvo-wheel-loaders-service-manual/>