

Document Title: <b>Machine identification</b>	Function Group: <b>000</b>	Information Type: <b>Service Information</b>	Date: <b>5/2/2026</b>
Profile: <b>PF6110 Volvo</b>			

## Machine identification

Showing Selected Profile

Valid for serial numbers			
Model	Production site	Serial number start	Serial number stop
PF6110 Volvo			

### Manufacturer

Volvo Construction Equipment  
 312 Volvo Way Shippensburg, Pennsylvania 17257  
 Phone: 717-532-9181 (Main Switchboard)  
 Phone: 1-800-227-0573 (Customer Service Parts)

### Name & Machine types

The highway-class Paver/Finisher, includes PF6110, PF6160 and PF6170.

### Serial number and product range

The serial number effectivity for the Paver/Finisher covered in this manual is outlined below.

Machine Series	Effective with Serial Numbers
PF6110	199150–199949 and 200654–
PF6160	199150–199949 and 200654–
PF6170	199150–199949 and 200654–

### Machine identification plate

The machine identification plate is located on the rear of the paver tractor directly under the right side operator seat. The plate contains important information about the machine including the model number, the manufacturing code and the product identification number (serial number).

This information should be recorded and kept in a convenient location for future reference.

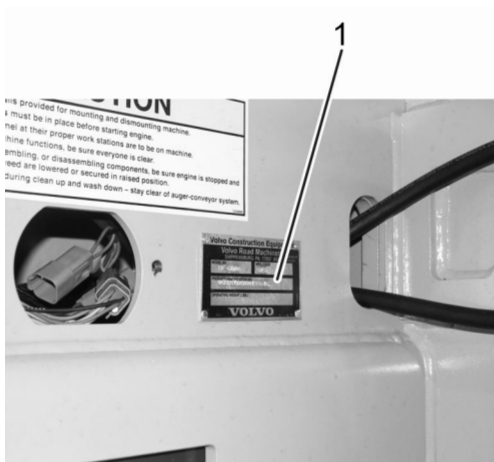

V1071271

### Figure 1

Vehicle Identification location on paver

Sample manual. Download All 807 pages at:

<https://www.arepairmanual.com/downloads/pf6110-volvo-tracked-pavers-service-manual/>

Product: PF6110 Volvo Tracked Pavers Service Manual

Full Download: <https://www.arepairmanual.com/downloads/pf6110-volvo-tracked-pavers-service-manual/>

1. vehicle identification plate

Sample manual. Download All 807 pages at:

<https://www.arepairmanual.com/downloads/pf6110-volvo-tracked-pavers-service-manual/>

Document Title: <b>Screed control unit</b>	Function Group: <b>000</b>	Information Type: <b>Service Information</b>	Date: <b>5/2/2026</b>
Profile: <b>PF6110 Volvo</b>			

## Description, complete machine

Showing Selected Profile

Valid for serial numbers			
Model	Production site	Serial number start	Serial number stop
PF6110 Volvo			

The PF6110 Paver/Finisher is a tracked highway class paver. It is designed for paving roadways from 2.1 m (7 ft.) to 7.92 m (26 feet) wide, depending upon the screed and screed extensions used.

The rated capacity of the Paver is 744 metric tons (820 tons) per hour. The minimum paving depth is 6.3 mm (.25 in.). The maximum paving depth is 30 cm (12 in.). The maximum paving depth below grade is 7.6 cm (3 in.).

The machine consists of two sections, the tractor and the screed. The tractor receives, delivers and spreads paving material in front of the screed, and tows the screed behind it. The screed levels, smooths and seals the asphalt on the mat and starts the compaction process. Screed extensions can be used individually or together (on one side or both sides) allowing a variable paving width towards the right or left.

The screed mounts to the tractor with two side arms, and floats on the top surface of the asphalt mat. The front of the side arms mount at the tow point, which can be raised or lowered by hydraulic cylinders. The rear of the side arms mount to the screed at the pivot point, which allows the screed to raise or lower as it floats on the mat.

The screed plate smooths and seals the mat surface. A strike-off plates control the amount of material to the screed plate. The angle at which the nose of the screed meets the asphalt, or the angle of attack, can be increased (RAISED) or decreased (LOWERED) using depth cranks mounted near the ends of the screed.

Screed lift cylinders mounted on the paver/finisher are used to raise the screed and are normally not used during paving operations. However, an optional hydraulic screed lock assist function allows the operator to lock the lift cylinders in place, or provide a lifting force that lightens the screed.

Edger plates mount to the ends of the screed to control the outward flow of material. Edger plates may be beveled to produce a sloped surface to the mat edge. Cut-off shoes can also work with the edger plate to further reduce the minimum paving width.

All screeds used with the PF6110 Paver/Finisher are heated electrically, to prevent the hot asphalt from sticking to the screed and tearing the mat. The heaters are powered by a 30 kW on-board generator.

The center of the screed can be raised, to provide a slope (or positive crown) from the center of the road towards the edges.

Initial compacting of the mat is achieved by a vibration unit in the screed. Some screed models provide a tamping function as well.

Features and options of the tractor, and each screed type offered, are described later in this Introduction.

Unique features of the PF6110 machine design include:

- Adjustable operator control stations for maximum comfort.
- Patented front wheel suspension that provides uniform loads on all wheels.
- Compatible with Blaw-Kontrol and TopCon systems.
- Auger drive mounted behind the conveyor.
- Automatic conveyor tensioning.
- On-board 30 kW generator.
- Three electrical screed heating circuits, with easily accessible heater bars.

Three separate micro processor controllers are provided. Each controls a basic machine function (operation), eliminating the need for routine operator involvement. The three controllers are:

Propulsion Controller.  
Auger/Conveyor Controller.  
Cooling Fan Controller.

## **PF6110 Tractor Features**

### **Operator controls**

Two control stations are provided on the rear deck of the machine, on the left and on the right. Each has a pedestal mounted control console, equipped with a lockable vandal cover, and a steering wheel.

The pedestals that support the consoles can be rotated to any of six positions, left or right, by depressing foot pedals on each side. The consoles themselves can be rotated up or down, to any convenient height within the limits of movement.

Forward and reverse movement of the machine, and the speed of the movement, is controlled by one of two FSR (Forward/Stop/Reverse) control levers, mounted next to the operator's seat.

The operator's seat, and FSR speed control housing, can be mounted to an optional sliding platform. This platform can be extended beyond the edge of the machine to provide better visibility for the operator.

### **Engine**

The PF6110 Paver/Finisher is powered by a six cylinder Cummins Tier III, QSB 6.7 B Series Turbo Electronic Engine with a Charge Air Cooler (CAC). The engine delivers 153kW (205 hp) of power at 1800 rpm. The engine is water cooled, and holds approximately 22.7 liters (6 gallons) of coolant, as a 50/50 mix of water and ethylene glycol or propylene glycol.

The engine has an oil cooler, a fuel cooler, replaceable oil and fuel filters, and an air cleaner with replaceable secondary and primary filters.

### **Engine fuel system**

The Cummins QSB 6.7 engine operates on No. 2 diesel fuel, supplied from a 290 liter (76.6 gallon) tank. There is a spin-on type fuel-water separator and a spin-on type fuel filter.

### **Electrical system**

Electrical power is derived from a 12-volt, negative ground electrical system. Electrical wiring is color coded, number imprinted and the harness is wrapped in polyethylene looms for maximum durability and ease of servicing.

An electrical junction box is provided in a separate compartment located above the right drive wheel.

A separate 30 kW generator powers the electrical screed heaters and optional lighting features.

### **Hydraulic system**

Hydraulic power is derived from an engine mounted four position pump box equipped with a lever actuated clutch. The box has an 0.67:1 speed up drive/pump ratio.

Separate pumps are provided for the generator drive (position 1), conveyor drive in tandem with the left side planetary wheel drive (position 2), general purpose pump and front wheel assist pumps (when required) in tandem (position 3) and the right side planetary wheel drive pump and auger drive pumps in tandem at (position 4).

The hydraulic oil tank has a 257 liters (68 gallons) capacity, including hydraulic oil and 10% air.

Hydraulic filtration includes suction filtration on charge pumps and return filtration on all open circuit pumps.

### **Hopper**

The 200 cm (80 in.) long hopper has a capacity of 6.5 cubic meters (230 cubic feet). The hopper wings have rounded corners to help prevent material build-up. The angled surfaces of the hopper promote self-cleaning.

### **Conveyors**

Dual-slat conveyors move material from the hopper to the augers. The total conveyor width is 144 cm (57 in.). The maximum conveyor speed is 40 meters per minute (132 feet per minute). The conveyors move independently of the paver, and deliver a constant volume of material to the augers. The conveyors can be operated in either the automatic or manual mode. The conveyor chain adjustment is automatic, using a hydraulic cylinder.

### **Augers**

Left-hand and right-hand augers receive material from the conveyors and spread it to the right and the left of the conveyor discharge location in front of the screed. The auger diameter is 43 cm (17 in.). The augers rotate at 140 rpm. The augers can be raised or lowered within the limits of 11.4 cm (4.5 in.) minimum, and 24 cm (9.5 in.) maximum. The augers can be operated in either the automatic or manual mode.

### **Auger Tunnel Extensions**

Auger tunnel extensions retain material between the screed extensions and the augers. These vertical retainers move IN or OUT hydraulically,

### **Parking brake**

A parking brake is provided. This allows the operator to set the brakes and maintain a stopped condition when the engine is running.

**Backup alarm**

An audible backup alarm is provided. It is active whenever the FSR speed control lever is in reverse.

**Split Auger/Conveyor System**

Contains independent left and right augers and left and right conveyors to better control material flow.

**Fume Recovery System**

An internal blower draws fumes from the hot mix at the auger area, and discharges them through the central stack, along with engine exhaust.

**Washdown System**

Pressurized washdown systems apply Blaw-Kote® to machine surfaces that contact asphalt, to prevent sticking. The system includes a Blaw-Kote® concentrate tank, a water storage tank, a washdown hose and hose reel.

**Oscillating Push Rollers**

Two rollers, one on each side, mount to the front oscillating bumper. The rollers maintain the proper truck position for unloading material into the machine hopper, and push the truck forward as paving progresses.

**Sliding Operator's Seat**

The operator's seat, and FSR speed control housing are mounted to a sliding platform. This platform can be extended beyond the edge of the machine to provide better visibility for the operator.

Document Title: <b>Tightening torques</b>	Function Group: <b>030</b>	Information Type: <b>Service Information</b>	Date: <b>5/2/2026</b>
Profile: <b>PF6110 Volvo</b>			

[Go back to Index Page](#)

## Tightening torque, specifications

Showing Selected Profile

Valid for serial numbers			
Model	Production site	Serial number start	Serial number stop
PF6110 Volvo	Shippensburg	199150	299999

### ISO Metric Torque chart

Use the following recommended torque chart for bolts and nuts of ISO Metric strength Class 8.8 or better. If other torques are required, they will be indicated in the text

Bolt Size	Torque	
	Nm	lbf ft
M6 x 1,0	12	9
M8 x 1,25	28	21
M10 x 1,5	61	45
M12 x 1,75	105	79
M14 x 2,0	170	125
M16 x 2,0	265	195
M20 x 2,5	515	380
M24 x 3,0	895	660
M30 x 3,5	1780	1310
M36 x 4,0	3100	2290
M42 x 3,5	4960	3660

#### NOTE!

Use High Strength thread locking compound on all bolts larger than M8.

#### NOTE!

Use Medium Strength thread locking compound on M8 bolts and smaller. Apply enough thread lock to fill all gaps between the engaged bolt and nut threads.

#### NOTE!

All thread fasteners will have Thread locking compound applied, except the following:

1. Wheel bolts/nuts
2. Nylon insert nuts
3. Whizlock bolts and nuts
4. Fasteners less than M6 diameter
5. If specifically instructed not to apply thread locking compound

Document Title: <b>Tightening torques</b>	Function Group: <b>030</b>	Information Type: <b>Service Information</b>	Date: <b>5/2/2026</b>
Profile: <b>PF6110 Volvo</b>			

[Go back to Index Page](#)

## Tightening torque, specifications

Showing Selected Profile

Valid for serial numbers			
Model	Production site	Serial number start	Serial number stop
PF6110 Volvo	Shippensburg	199150	299999

### SAE Torque charts

Use the following recommended torque charts for bolts and nuts of SAE Grade 5 or better quality. If other torques are required, they will be indicated in the text.

Bolt (Coarse)	Torque		Bolt (Fine)	Torque	
	Nm	lbf ft		Nm	lbf ft
1/4 – 20	12	9	1/4 – 28	15	11
5/16 – 18	26	19	5/16 – 24	28	21
3/8 – 16	50	37	3/8 – 24	57	42
7/16 – 14	80	59	7/16 – 20	89	66
1/2 – 13	122	90	1/2 – 20	136	100
9/16 – 12	176	130	9/16 – 18	197	145
5/8 – 11	244	180	5/8 – 18	278	205
3/4 – 10	434	320	3/4 – 16	481	355
7/8 – 9	698	515	7/8 – 14	773	570
1 – 8	1051	775	1 – 12	1146	845
1 1/8 – 7	1492	1100	1 1/8 – 12	1668	1230
1 1/4 – 7	2088	1540	1 1/4 – 12	2319	1710
1 3/8 – 6	2739	2020	1 3/8 – 12	3119	2300
1 1/2 – 6	3648	2690	1 1/2 – 12	4095	3020

**NOTE!**

Torque values used in this table are based on plated, yellow zinc, dichromate bolts.

**NOTE!**

Use medium strength thread locking compound on bolts 5/16 inch and smaller to fill all gaps between the engaged bolt and nut threads.

**NOTE!**

All thread fasteners will have thread locking compound applied, except the following:

1. Wheel bolts/nuts
2. Nylon insert nuts
3. Whizlock bolts and nuts
4. Fasteners less than 1/4-inch diameter
5. If specifically instructed not to apply thread locking compound

Document Title: <b>Conversion tables</b>	Function Group: <b>030</b>	Information Type: <b>Service Information</b>	Date: <b>5/2/2026</b>
Profile: <b>PF6110 Volvo</b>			

## Conversion tables

Showing Selected Profile

Valid for serial numbers			
Model	Production site	Serial number start	Serial number stop
PF6110 Volvo			

### Length

Unit	cm	m	km	in	ft	yd	mile
cm	1	0.01	0.00001	0.3937	0.03281	0.01094	0.000006
m	100	1	0.001	39.37	3.2808	1.0936	0.00062
km	100000	1000	1	39370.7	3280.8	1093.6	0.62137
in	2.54	0.0254	0.000025	1	0.08333	0.02777	0.000015
ft	30.48	0.3048	0.000304	12	1	0.3333	0.000189
yd	91.44	0.9144	0.000914	36	3	1	0.000568
mile	160930	1609.3	1.6093	63360	5280	1760	1

1 mm = 0.1 cm - 1 mm = 0.001 m

### Area

Unit	cm <sup>2</sup>	m <sup>2</sup>	km <sup>2</sup>	a	ft <sup>2</sup>	yd <sup>2</sup>	in <sup>2</sup>
cm <sup>2</sup>	1	0.0001	-	0.000001	0.001076	0.000012	0.155000
m <sup>2</sup>	10000	1	0.000001	0.01	10.764	1.1958	1550.000
km <sup>2</sup>	-	1000000	1	10000	1076400	1195800	-
a	0.01	100	0.0001	1	1076.4	119.58	-
ft <sup>2</sup>	-	0.092903	-	0.000929	1	0.1111	144.000
yd <sup>2</sup>	-	0.83613	-	0.008361	9	1	1296.00
in <sup>2</sup>	6.4516	0.000645	-	-	0.006943	0.000771	1

1 ha = 100 a - 1 mile<sup>2</sup> = 259 ha = 2.59 km<sup>2</sup>

### Volume

Unit	cm <sup>3</sup> = cc	m <sup>3</sup>	l	in <sup>3</sup>	ft <sup>3</sup>	yd <sup>3</sup>
cm <sup>3</sup> = ml	1	0.000001	0.001	0.061024	0.000035	0.000001
m <sup>3</sup>	1000000	1	1000	61024	35.315	1.30796
dm <sup>3</sup> (l)	1000	0.001	1	61.024	0.035315	0.001308
in <sup>3</sup>	16.387	0.000016	0.01638	1	0.000578	0.000021
ft <sup>3</sup>	28316.8	0.028317	28.317	1728	1	0.03704
yd <sup>3</sup>	764529.8	0.76453	764.53	46656	27	1

1 gal (US) = 3785.41 cm<sup>3</sup> = 231 in<sup>3</sup> = 0.83267 gal (UK)

### Weight

Unit	g	kg	t	oz	lb
g	1	0.001	0.000001	0.03527	0.0022
kg	1000	1	0.001	35.273	2.20459
t	1000000	1000	1	35273	2204.59
oz	28.3495	0.02835	0.000028	1	0.0625
lb	453.592	0.45359	0.000454	16	1

1 ton (metric) = 1.1023 ton (US) = 0.9842 ton (UK)

### Pressure

Unit	kp/cm <sup>2</sup>	bar	Pa=N/m <sup>2</sup>	kPa	lbf/in <sup>2</sup>	lbf/ft <sup>2</sup>
kp/cm <sup>2</sup>	1	0.98067	98066.5	98.0665	14.2233	2048.16
bar	1.01972	1	100000	100	14.5037	2088.6
Pa=N/m <sup>2</sup>	0.00001	0.001	1	0.001	0.00015	0.02086
kPa	0.01020	0.01	1000	1	0.14504	20.886
lbf/in <sup>2</sup>	0.07032	0.0689	6894.76	6.89476	1	144
lbf/ft <sup>2</sup>	0.00047	0.00047	47.88028	0.04788	0.00694	1

kg/cm<sup>2</sup> = 735.56 Dry (mmHg) = 0.96784 atm

### Unit explanations

Unit	abbreviation
Newton meter	Nm
Kilopoundmeter	kpm
Kilopascal	kPa
Megapascal	MPa
Kilowatt	kW
kilojoule	kJ
British thermal unit	Btu
Calorie	ca

### Approx. conversion

SI unit	Conversion factor	Non SI	Conversion factor	SI
<b>Torque</b>				
Nm	x10.2	=kg/cm	x0.8664	=lb in
Nm	x0.74	=lbf-ft	x1.36	=Nm
Nm	x0.102	=kg/m	x7.22	=lbft
<b>Pressure (Pa = N/m<sup>2</sup>)</b>				
kPa	x4.0	=in.H <sub>2</sub> O	x0.249	=kPa
kPa	x0.30	=in.Hg	x3.38	=kPa
kPa	x0.145	=psi	x6.89	=kPa
bar	x14.5	=psi	x0.069	=bar
kp/cm <sup>2</sup>	x14.22	=psi	x0.070	=kp/cm <sup>2</sup>
N/mm <sup>2</sup>	x145.04	=psi	x0.069	=bar
MPa	x145	=psi	x0.00689	=MPa
<b>Power (W = J/s)</b>				
kW	x1.36	=hp(cv)	x0.736	=kW

kW	x1.34	= bhp	x0.746	= kW
kW	x0.948	= Btu/s	x1.055	= kW
W	x0.74	= ft-lb/s	x1.36	= W
Energy (J = Nm)				
kJ	x0.948	= Btu	x1.055	= kJ
J	x0.239	= calorie	x4.19	= J
Speed and acceleration				
m/s <sup>2</sup>	x3.28	= ft/s <sup>2</sup>	x0.305	= m/s <sup>2</sup>
m/s	x3.28	= ft/s	x0.305	= m/s
km/h	x0.62	= mph	x1.61	= km/h
Horsepower/torque				
Bhp x5252 rpm = TQ (lb-ft)			TQ x rpm 5252 = bhp	
Temperature				
$^{\circ}\text{C} = (^{\circ}\text{F} - 32) / 1.8$			$^{\circ}\text{F} = (^{\circ}\text{C} \times 1.8) + 32$	
Flow factor				
l/min (dm <sup>3</sup> /min)	x0.264	= US gal/min	x3.785	= liter/min

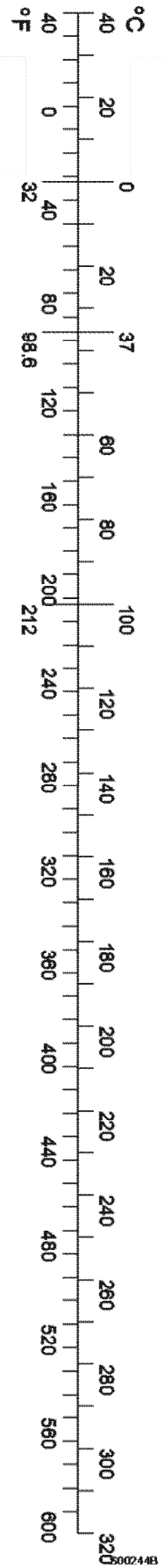

Figure 1

Document Title: <b>Thread locking compound, application/specifications</b>	Function Group: <b>030</b>	Information Type: <b>Service Information</b>	Date: <b>5/2/2026</b>
Profile: <b>PF6110 Volvo</b>			

## Thread locking compound, application/specifications

Showing Selected Profile

Valid for serial numbers			
Model	Production site	Serial number start	Serial number stop
PF6110 Volvo	Shippensburg	199150	299999

### General

#### NOTE!

Verify that the thread locking compound is not expired!

#### NOTE!

Do not apply thread locker to: wheel nuts, nylon insert nuts, whiz fasteners, electrical fasteners, ground cables/bolts or fasteners less than 6 mm (1/4 in) in diameter.

#### Non-threaded through hole, bolt and nut

1. Clean all parts as necessary.
2. Insert bolt through hole.
3. Apply several drops of specified thread locking compound to the bolt where the nut will seat.
4. Assemble, tighten and torque as usual.

#### Threaded through hole

1. Clean all parts as necessary.
2. Apply several drops of specified thread locking compound to bolt.
3. Assemble, tighten and torque as usual.

#### Threaded blind hole

1. Clean all parts as necessary.

#### NOTE!

Be sure to remove any foreign material from threaded hole.

2. Apply several drops of specified thread locking compound into threaded hole.
3. Apply several drops of specified thread locking compound to bolt.
4. Assemble, tighten and torque as usual.

Document Title: <b>Critical mounting torques</b>	Function Group: <b>030</b>	Information Type: <b>Service Information</b>	Date: <b>5/2/2026</b>
Profile: <b>PF6110 Volvo</b>			

## Critical mounting torques

Showing Selected Profile

Valid for serial numbers			
Model	Production site	Serial number start	Serial number stop
PF6110 Volvo			

Use the following recommended torque chart for bolts and nuts of SAE Grade 5 or better quality. If other torques are required, they will be indicated in the text.

### Critical mounting torques

Function of fastener	Size	Torque		Thread locking compound strength (if required)
		N·m	lb-ft	
Auger shaft bearing cover, socket head screws		100	75	none
Auger shaft bearing setscrew (inside cover)		35	25	none
Reversing auger hydraulic manifold valve, socket head screws		14	10	none
Auger lift cylinder guide plate to auger assembly, bolt	M12	150	110	none
Auger motor backing plate counter sunk screw		88	65	none
Reversing conveyor hydraulic manifold valve, socket head screws		14	10	none
Pump box to bell housing, socket head screws	M10	55	41	high
Radiator stiffener to radiator, bolt	M10	47	35	high
Pedestal mounting plate lock nut	M140	135.5	100	none
Engine sub frame to bell housing, bolt	M12	101	75	high
Rear engine mount to pump box, bolt	M12	105	79	high
Rear engine mount to rear engine brace, bolt	M10	86	64	none
Engine coupling centre hub, socket head screw		50	37	none
Clutch ring gear to flywheel, bolt	3/8-16	72	52	high
Front and rear engine isolator, bolt	3/4-10	270	195	high
Compensation cylinders to main frame		265	195	none

Fan to motor assembly locknut	Cummins	40-51	29-37	medium
Fan motor assembly to finger guard	M10	54	40	medium
Air cleaner to air cleaner mounting bracket, bolt	M8	20	15	medium
Bogie wheel mounting nuts		290	214	none
Fan hub assembly setscrews		10	8	medium
Planetary/motor assembly to mainframe	M20	340	250	none
Power tunnel cylinder to main frame	M20	136	100	none
Tunnel cylinder rod to tunnel end cap (2) hex nut	M20	272	200	none
Tunnel end cap to main frame	M10	61.2	45	none
Drive wheel to planetary, bolt	M20	510	376	high
Screed cylinder saddle, bolt	M12	105	79	high
Screed assist, 2-way valve cartridge		30	23	none
Screed assist, pressure reducing valve		44	33	none
Screed lock, valve	Bolt	44	33	none
Screed plate mounting bolts		47	35	none

Document Title: <b>Diesel fuels - quality and function</b>	Function Group: <b>030</b>	Information Type: <b>Service Information</b>	Date: <b>5/2/2026</b>
Profile: <b>PF6110 Volvo</b>			

## Diesel fuels - quality and function

Showing Selected Profile

Valid for serial numbers			
Model	Production site	Serial number start	Serial number stop
PF6110 Volvo			

ATTRIBUTE	REQUIREMENTS
Viscosity (ASTM D-445)	1.3 to 5.8 centistokes per second at 40° C (104° F)
Cetane Number (ASTM D-613)	40 minimum at temperatures above 0° C (32° F). 45 minimum at temperatures below 0° C (32° F).
Sulfur Content (ASTM D-129 or 1552)	Not to exceed 0.05% by weight highway; not to exceed .029% by weight off road.
Water and Sediment (ASTM D-1796)	Not to exceed 0.1% by volume.
Carbon Residue (Ramsbottom ASTM D-524 or Conradson, ASTM D-189)	Not to exceed 0.25% by weight on 10% volume residue.
Flash Point (ASTM D-287)	At least 52° C (125° F) or legal temperature if higher than 52° C (125° F).
Density (ASTM D-287)	-1° C to 6° C (30° F to 42° F) API Gravity at 16° C (60° F) (0.816 to 0.876 Sp. Gr.)
Cloud Point (ASTM D-97)	6° C (10° F) below lowest ambient temperature at which the fuel is expected to operate.
Active Sulfur	Copper strip corrosion not to exceed No. 2 rating after 3 hours at 49° C (122° F).
Ash (ASTM D-482)	Not to exceed 0.02% by weight.
Distillation (ASTM D-86)	The distillation curve must be smooth and continuous. At least 90% of the fuel must evaporate at less than 360° C (680° F). All of the fuel must evaporate at 385° C (725° F).

Document Title: <b>Hydraulic connections, tightening torques</b>	Function Group: <b>030</b>	Information Type: <b>Service Information</b>	Date: <b>5/2/2026</b>
Profile: <b>PF6110 Volvo</b>			

## Hydraulic connections, tightening torques

Showing Selected Profile

Valid for serial numbers			
Model	Production site	Serial number start	Serial number stop
PF6110 Volvo	Shippensburg	199150	299999

### JIC-coupling

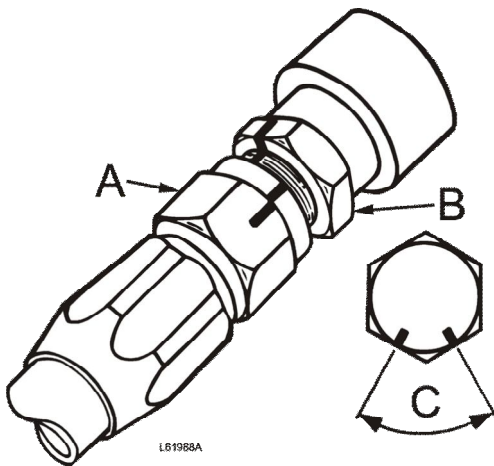

Figure 1

Hose coupling dimension (A)	Coupling size (B)	Tightening, number of hex edges (C)
9/16"		2 1/2 (150°)
5/8"	7/8"-14	2 1/2 (150°)
11/16"		2 (120°)
7/8"	1 3/16"-12	2 (120°)
1"	1 5/16"-12	1 1/2-2 (90°- 120°)
1 1/4"	1 5/8"-12	1 (60°)
1 1/2"	1 7/8"-12	3/4-1 (45°- 60°)
2"		3/4-1 (45°- 60°)
2 1/4"		1/2-1 (30°- 60°)

Tighten the coupling so that the metal surfaces in the connection are in contact with each other. Then tighten the nut as follows:

### ORFS-coupling

Always install a new O-ring before an ORFS-coupling is assembled.

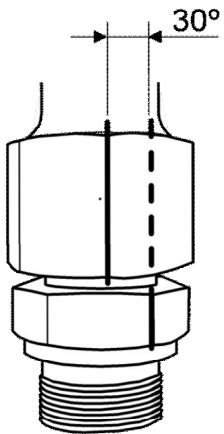

V1028462

**Figure 2**

Tighten the coupling so that the O-ring is compressed and the metal surfaces in the coupling are in contact with each other. Then tighten the nut another:

- 1/2 hex edge (30°) if the coupling is new.
- 1/4—1/2 hex edge (15°—30°) if the coupling is used (when only changing O-ring).

**NOTE!** Avoid twisting of the hose by using counterhold on the hose's hex edge.

**NOTE!!** In case of leakage, it does not help to tighten further, the O-ring must be changed.

**Thread sealant**

It is recommended to use lubricating thread sealant for any high pressure hose connections and fittings that are not JIC or ORFS fittings.

Document Title: <b>Operation numbers for additional work</b>	Function Group: <b>070</b>	Information Type: <b>Service Information</b>	Date: <b>5/2/2026</b>
Profile: <b>Tracked Pavers (PAT)</b>			

## Operation numbers for additional work

Showing Selected Profile

These operations can be used to identify work that is not included in the time guide or described in the methods in the Service Manual. When these operations are used, a description of the work that has been performed must be provided.

### Other work related to engine

Op. no. 070-210

This operation can be used when work has been done related to the engine and function group 2 when no applicable method description was available. When this operation is used, additional information is required:

- Description of work that has been done

### Other work related to electrical system

Op. no. 070-310

This operation can be used when work has been done related to the electrical system and function group 3 when no applicable method description was available. When this operation is used, additional information is required:

- Description of work that has been done

### Other work related to transmission, gearbox, travel motor, swing motor

Op. no. 070-410

This operation can be used when work has been done related to the transmission, gearbox, travel motor or swing motor and function group 4 when no applicable method description was available. When this operation is used, additional information is required:

- Description of work that has been done

### Other work related to drive axle

Op. no. 070-470

This operation can be used when work has been done related to the drive axle and function group 46 when no applicable method description was available. When this operation is used, additional information is required:

- Description of required work that have been done

### Other work related to brake system

Op. no. 070-510

This operation can be used when work has been done related to the brake system and function group 5 when no applicable

method description was available. When this operation is used, additional information is required:

- Description of work that has been done

**Other work related to steering system**

Op. no. 070-610

This operation can be used when work has been done related to the steering system and function group 6 when no applicable method description was available. When this operation is used, additional information is required:

- Description of work that has been done

**Other work related to frame link, axle suspension**

Op. no. 070-710

This operation can be used when work has been done related to the frame link, axle suspension and other parts related to function group 7 when no applicable method description was available. When this operation is used, additional information is required:

- Description of work that has been done

**Other work related to cab, air conditioning**

Op. no. 070-810

This operation can be used when work has been done related to the cab, air conditioning and other parts related to function group 8 when no applicable method description was available. When this operation is used, additional information is required:

- Description of work that has been done

**Other work related to hydraulic system**

Op. no. 070-910

This operation can be used when work has been done related to the hydraulic system and other parts related to function group 9 when no applicable method description was available. When this operation is used, additional information is required:

- Description of work that has been done

Document Title: <b>E-7003</b>	Function Group: <b>080</b>	Information Type: <b>Service Information</b>	Date: <b>5/2/2026</b>
Profile: <b>PF6110 Volvo</b>			

## E-7003

Showing Selected Profile

Valid for serial numbers			
Model	Production site	Serial number start	Serial number stop
PF6110 Volvo			

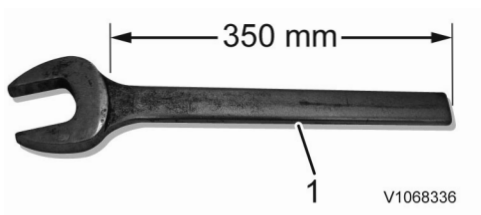

**Figure 1**

Hydraulic strainer modified wrench

1. 2 1/4 inch open end wrench

Document Title: <b>Recommended lubricants</b>	Function Group: <b>160</b>	Information Type: <b>Service Information</b>	Date: <b>5/2/2026</b>
Profile: <b>PF6110 Volvo</b>			

## Recommended lubricants

Showing Selected Profile

<b>Valid for serial numbers</b>			
<b>Model</b>	<b>Production site</b>	<b>Serial number start</b>	<b>Serial number stop</b>
PF6110 Volvo			

<b>Recommended Lubricants, specification</b>	
Engine oil	Multi-Purpose Premium Engine Oil - SAE 15W-40
Hydraulic oil	ISO VG 68; with anti-wear additives; VI 129(minimum)
Extreme pressure multi-purpose grease	MPG-EP2; NLGI-EP2
Synthetic component lubricant	Synthetic hydrocarbon with phosphorus; ISO VG220; VI 152
Extreme pressure gear lubricant	SAE 85W-140W; API GL-5; MIL PRF 2105E
For the latest applicable engineering lubricating oil specifications, contact the engine manufacturer, or your manufacturer's authorized dealer or distributor.	

**NOTE!**

For additional information and specifications regarding lubrication, filling capacities and maintenance, refer to the tables [Fuel, lubricant and filling capacities](#) in the Specifications Section 1.

Document Title: <b>Lubricant recommendation</b>	Function Group: <b>160</b>	Information Type: <b>Service Information</b>	Date: <b>5/2/2026</b>
Profile: <b>PF6110 Volvo</b>			

## Lubricant recommendation

Showing Selected Profile

Valid for serial numbers			
Model	Production site	Serial number start	Serial number stop
PF6110 Volvo	Shippensburg	199150	299999

### GENERAL INFORMATION

Lubrication is an essential part of preventive maintenance, affecting to a great extent the useful life of the unit. Periodic lubrication of the moving parts reduces to a minimum the possibility of mechanical failures.

For maximum machine life and performance, we recommend the use of genuine authorized brand lubricants. Refer to [Recommended lubricants](#).

Different lubricants are needed and some components in the unit require more frequent lubricant than others. Therefore, it is important that the instructions regarding types of lubricant and frequency of the application be explicitly followed.

To obtain the maximum long-life results from the machine, a regular service programme should be followed as recommended in this manual. The suggested intervals are based on average operating conditions. In extremely severe, dusty or wet operating conditions, more frequent lubrication may be necessary.

The Lubrication Chart that follows in this section shows those items requiring regular service and the interval at which they should be performed. Details concerning fuel, oil and other lubricants follow the lubrication chart. A regular service program should be geared to the items listed under each interval. These intervals are based on average operating conditions. In the event of extremely severe, dusty or wet operating conditions, more frequent lubrication than specified may be necessary.

All oil levels are to be checked with the machine parked on a level surface and while the oil is cold, unless otherwise specified.

On plug-type check points, the oil levels are to be at the bottom edge of the check port.

All grease fittings are SAE STANDARD, unless otherwise indicated. Grease non-sealed fittings until grease is seen extruding from the fitting.

Over-lubrication on non-sealed fittings will not harm the fittings or components, but under lubrication will definitely lead to a shorter life.

Unless otherwise indicated, items not equipped with grease fittings (linkages, pins, levers, etc.) should be lubricated with oil once a week. Motor oil, applied sparingly, will provide the necessary lubrication and help prevent the formation of rust. An anti-seize compound may be used if rust has not formed. Otherwise, the component must be cleaned first.

Grease fittings must be replaced when they are worn to the point that they fail to hold the grease gun, or when they have a stuck check ball.

To prevent problems, other services or checks are recommended at the time of lubrication.

1. Clean around fittings and drain, check level and fill plugs before removing or replacing them. Wash them with a non-flammable, non-toxic, cleaning solution.
2. Ensure that lubricants are at operating temperature when draining.

Document Title: <b>Lubrication and oil system, general specifications</b>	Function Group: <b>160</b>	Information Type: <b>Service Information</b>	Date: <b>5/2/2026</b>
Profile: <b>PF6110 Volvo</b>			

## Lubrication and oil system, general specifications

Showing Selected Profile

Valid for serial numbers			
Model	Production site	Serial number start	Serial number stop
PF6110 Volvo			

### Extreme Pressure Multipurpose Lubricant

This gear lubricant is compounded to achieve high load carrying capacity and meet the requirements of either API-GL-5 or MIL-L-2105C. Unless otherwise specified, SAE-90 viscosity oil may be used for year-round service. Low temperature usage is restricted as follows:

SAE VISCOSITY NO.	MIN. AMBIENT TEMP °C (° F)
75W	-40° C (-40° F)
80W	-26° C (-15° F)
85W	-12° C (+10° F)
90	-7° C (+20° F)
140	+4° C (+40° F)
250	+10° C (+50° F)

### Extreme Pressure Multi-Purpose Grease

This is a lithium soap base grease with a high load carrying capacity. The following properties are recommended:

Timken OK Load	18 kg (40 lb) Minimum
Dropping Point	177° C (350° F) Minimum
Oil Viscosity	75 SUS Minimum at 99° C (210° F)
Water Resistance	Excellent

Under normal operating conditions, the following consistency grades are recommended:

NLGI No. 0 for temperatures below -18° C (0° F).
NLGI No. 1 or No. 2 for ambient temperatures -18° C to 38° C (0° F – 100° F).
NLGI No. 2 or No. 3 for temperatures over 38° C (100° F).

### Engine Lube Oil Specifications

#### NOTE!

For latest applicable engine lubricating oil specifications, contact engine manufacturer, engine distributor or your Volvo Construction Equipment dealer.

Document Title: <b>Hydraulic oil, specifications</b>	Function Group: <b>160</b>	Information Type: <b>Service Information</b>	Date: <b>5/2/2026</b>
Profile: <b>PF6110 Volvo</b>			

## Hydraulic oil, specifications

Showing Selected Profile

Valid for serial numbers			
Model	Production site	Serial number start	Serial number stop
PF6110 Volvo			

The quality of the hydraulic oil is important to the satisfactory performance of any hydraulic system. The oil serves as the hydrostatic drive medium, system coolant and lubricant. Selection of the proper oil is essential to ensure proper system performance and life. Refer to the table below for the specifications and requirements that hydraulic oil used in this machine should meet.

Viscosity:	60 SUS minimum at operating temperature 7500 SUS maximum at starting temperature 150 to 225 SUS at 38° C (100° F) (generally) 44 to 48 SUS at 99° C (210° F) (generally)
Viscosity Index:	90 minimum
Aniline Point:	-175 minimum
API gravity:	28 Minimum Paraffinic oils: 28 or more Mixed base: 24 to 28 Napthanic or asphaltic base: 24 or less
Recommended Additives:	Rust and oxidation inhibitors Foam depressant
Desirable Characteristics:	Stability of physical and chemical characteristics High demulsibility (low emulsibility) for separation of water, air and contaminants Resistance to the formation of gums, sludges, acids, tars and varnishes High lubricity and film strength

The following are a few examples of the commercial brand oils meeting specifications.

Mobil Oil Company	Mobil DTE 16M
-------------------	---------------

Document Title: <b>Fuel, lubricant and filling capacities</b>	Function Group: <b>160</b>	Information Type: <b>Service Information</b>	Date: <b>5/2/2026</b>
Profile: <b>PF6110 Volvo</b>			

## Fuel, lubricant and filling capacities

Showing Selected Profile

Valid for serial numbers			
Model	Production site	Serial number start	Serial number stop
PF6110 Volvo			

The following approximate fluid capacities are provided for servicing where shop facilities and resources are not available.

FLUID/OIL	APPROXIMATE CAPACITY
Diesel Fuel	290 L (76.6 gal.)
Hydraulic Oil	257 L (67.8 gal.)
Engine Oil	14 L (3.7 gal.)
Engine Coolant	22.7 L (6 gal.)
Pump Drive Box	5.7 L (1.5 gal.)
Traction Planetary (each)	3.33 L (0.88 gal.)

Document Title: <b>Diesel fuels - quality and function</b>	Function Group: <b>160</b>	Information Type: <b>Service Information</b>	Date: <b>5/2/2026</b>
Profile: <b>PF6110 Volvo</b>			

## Diesel fuels - quality and function

Showing Selected Profile

Valid for serial numbers			
Model	Production site	Serial number start	Serial number stop
PF6110 Volvo			

ATTRIBUTE	REQUIREMENTS
Viscosity (ASTM D-445)	1.3 to 5.8 centistokes per second at 40° C (104° F)
Cetane Number (ASTM D-613)	40 minimum at temperatures above 0° C (32° F). 45 minimum at temperatures below 0° C (32° F).
Sulfur Content (ASTM D-129 or 1552)	Not to exceed 0.05% by weight highway; not to exceed .029% by weight off road.
Water and Sediment (ASTM D-1796)	Not to exceed 0.1% by volume.
Carbon Residue (Ramsbottom ASTM D-524 or Conradson, ASTM D-189)	Not to exceed 0.25% by weight on 10% volume residue.
Flash Point (ASTM D-287)	At least 52° C (125° F) or legal temperature if higher than 52° C (125° F).
Density (ASTM D-287)	-1° C to 6° C (30° F to 42° F) API Gravity at 16° C (60° F) (0.816 to 0.876 Sp. Gr.)
Cloud Point (ASTM D-97)	6° C (10° F) below lowest ambient temperature at which the fuel is expected to operate.
Active Sulfur	Copper strip corrosion not to exceed No. 2 rating after 3 hours at 49° C (122° F).
Ash (ASTM D-482)	Not to exceed 0.02% by weight.
Distillation (ASTM D-86)	The distillation curve must be smooth and continuous. At least 90% of the fuel must evaporate at less than 360° C (680° F). All of the fuel must evaporate at 385° C (725° F).

Document Title: <b>Alternative fuels</b>	Function Group: <b>160</b>	Information Type: <b>Service Information</b>	Date: <b>5/2/2026</b>
Profile: <b>Tracked Pavers (PAT)</b>			

## Alternative fuels

Showing Selected Profile

**This statement is only valid for Volvo branded engines.**

Hydro-treated vegetable oil (HVO) and fatty acid methyl ester (FAME) biodiesel are both made from renewable raw materials such as vegetable oils and animal fats, but they are chemically processed in different ways.

### Hydro-treated vegetable oil (HVO)

HVO is created using a chemical process called hydro-treating. Hydro-treating creates an oxygen-free hydrocarbon product that is very similar to distillate diesel fuel and is well suited for use in diesel engines. HVO fuels complying with the CEN diesel fuel standard EN 590:2013 or with the European Fuel Quality Directive 98/70/EC are approved for use in all Volvo Construction Equipment diesel engines with no changes to maintenance intervals. Paraffinic diesel fuels complying with the CEN standard EN 15940 may be used in all machines operating outside the European Union and for EU-certified engines up to the emission level Stage IV. These fuels may also be used for the EU-certified D11, D13 and D16 engines meeting the emission level Stage V.

### Biodiesel

Biodiesel is a product made from renewable resources such as vegetable oils or animal fat. Biodiesel that has been chemically processed into fatty acid methyl ester (FAME) can be blended with distillate diesel fuel and used in some diesel engines. Unblended biodiesel is referred to as B100 because it is 100% biodiesel.

Rapeseed methyl ester (RME) is the most common type of FAME used in Europe. Soy methyl ester (SME) and sunflower oil methyl ester (SOME) are the most common types of FAME used in the US.

Although use of FAME biodiesel is now a legal requirement in some markets, it is not as suitable for use in diesel engines as conventional diesel fuel or HVO (hydro-treated vegetable oil).

### Biodiesel fuel requirements

The FAME biodiesel blends specified in the table below are approved for use if:

- The biodiesel is pre-blended by the fuel supplier
- The biodiesel used in the blend conforms to EN14214 or ASTM D6751
- The distillate fuel used in the blend meets fuel sulphur requirements
- The distillate fuel used in the blend conforms to EN590 or ASTM D975
- B1-B5 biodiesel blends conform to EN590 or ASTM D975
- B6-B7 biodiesel blends conform to EN590 or ASTM D7467
- B8-B20 biodiesel blends conform to EN16709(B20) or ASTM D7467

Engine emission designation	Engine size	Acceptable blend
EU Stage II / US Tier 2 * EU Stage IIIA / US Tier 3 * EU Stage IIIB / US Tier 4 interim EU Stage IV / US Tier 4 final EU Stage V	Below D4 / 4 litres	Up to B7
EU Stage II / US Tier 2 * EU Stage IIIA / US Tier 3 * EU Stage IIIB / US Tier 4 interim EU Stage IV / US Tier 4 final	D4–D8	Up to B7
EU Stage II / US Tier 2 * EU Stage IIIA / US Tier 3 * US Tier 4 final, special North America arrangement **	D9–D16	Up to B20
EU Stage IIIB / US Tier 4 interim EU Stage IV / US Tier 4 final	D11–D16	Up to B10

EU Stage IIIB / US Tier 4 interim, equipped with High Sulphur Fuel Conversion Kit (only available in unregulated markets)	D4–D16	Up to B20
EU Stage IV / US Tier 4 final, equipped with High Sulphur Fuel Conversion Kit (only available in unregulated markets)		
EU Stage V	D4–D16	Up to B7
<p>* As Tier 2 and Tier 3 emissions regulations ended in 2005 and 2010 respectively, engines produced since then typically <b>meet Stage II / Stage IIIA regulations</b>, allowing their sale in less regulated markets.</p> <p>** With additional restrictions and special operating conditions, equipment used in North America may operate on B20 diesel.</p>		

#### NOTE!

Failures directly caused by the use of poor quality biofuel, or any other fuel not conforming to standards, are not factory defects and the manufacturer's warranty does not apply.

#### Maintenance interval requirements

Additional service actions and shorter maintenance intervals are mandatory when using biodiesel blends above B10.

<b>Every 10 hours</b>
<ul style="list-style-type: none"> <li><input type="radio"/> Check the engine oil and change if it rises above the maximum fill level</li> <li><input type="radio"/> Inspect the fuel system components and replace as necessary</li> </ul>
<b>Half of original interval</b>
<ul style="list-style-type: none"> <li><input type="radio"/> Change the engine oil and filter</li> <li><input type="radio"/> Replace the fuel filter(s)</li> </ul>
<b>Every year, regardless of operating hours</b>
<ul style="list-style-type: none"> <li><input type="radio"/> Change the engine oil and filter</li> <li><input type="radio"/> Clean the fuel tank</li> </ul>

#### Effects of biodiesel on engine oil

Using biodiesel can lead to increased oil dilution. Use engine oil analysis tools frequently to check for fuel dilution and monitor engine oil condition. Check the engine oil level daily. Always change the engine oil if the oil level rises above the maximum fill level.

#### Effects of biodiesel on fuel systems

Biodiesel dissolves and loosens some fuel system deposits. During the initial conversion to biodiesel, loosened deposits will travel to the fuel filters and require more frequent fuel filter replacements. Start with new fuel filters when using biodiesel for the first time.

Biodiesel is aggressive to some materials used in fuel system components. Inspect seals, hoses, rubber and plastic components every 10 hours. Repair or replace any components that are damaged, softened or leaking. Clean biodiesel from painted surfaces immediately to prevent paint damage.

Biodiesel is more sensitive to bacteria and water contamination than distillate diesel fuel.

- Use as much fuel as possible before refilling the fuel tank in order to prevent bacteria growth if a machine is in regular use, e.g. regularly uses up a tank of fuel within a week. In climates where condensation is a risk, or when the machine is working for short durations, keep the fuel tank full.
- Do not use biodiesel in machines with low utilization or operating time.
- Do not store machines for more than 4 weeks without flushing biodiesel out of the fuel system by operating the machine through at least one full tank of distillate diesel fuel.
- Always follow the manufacturer's storage recommendations and "best-before" dates for each delivery of biodiesel.

#### Effects of biodiesel on exhaust aftertreatment systems

Biodiesel leaves higher levels of ash in diesel particulate filters and may require more frequent diesel particulate filter (DPF) regeneration and cleaning. Biodiesel can cause deviations in temperatures and functionality of the DPF burner and may cause fault codes or errors.

Biodiesel exhaust gas is aggressive to some materials used in selective catalytic reduction systems (SCR) and may require more frequent cleaning, repairing or replacing of SCR parts.

**Effects of biodiesel on cold weather operation**

Biodiesel has a high viscosity at temperatures below 0 °C (32 °F) and may cause problems starting the engine. Use a fuel heater or park machines in a heated building if possible.

**Effects of biodiesel on engine performance**

Biodiesel B100 has about 8% lower energy density compared to regular diesel fuel. Blends equal or lower than B20 have a small impact on engine performance.

**Effects of biodiesel on emissions compliance**

Engines are certified to comply with U.S. EPA, California and EU emissions standards based upon the use of test fuels with specifications established by these regulatory agencies. Alternative fuels, including biodiesel, that are not substantially similar to the required test fuels may adversely affect engine emissions compliance. As a result, Volvo does not warrant that the engine will conform to applicable Federal or California and EU emissions limits when operated on, or having previously being operated on, biodiesel or other alternative fuels that are not substantially similar to specified test fuels used for certification, nor if biodiesel / regular diesel is used in blends that exceed the recommendations.

However, the use of biodiesel up to a maximum of 20% (B20) in and of itself, will not affect the manufacturer's mechanical warranty as to engine or emissions system, provided the bio fuel used in the blend conforms to the applicable standards and the additional steps outlined herein are followed.

Document Title: <b>Arrival Inspection, according to Inspection Programme</b>	Function Group: <b>171</b>	Information Type: <b>Service Information</b>	Date: <b>5/2/2026</b>
Profile: <b>Tracked Pavers (PAT)</b>			

## **Arrival Inspection, according to Inspection Programme**

**Op nbr 171-001**

**Total procedure time (hr): 0.80**

1. This Inspection Programme can be found as a PDF file in the document library in PROSIS.

Product: PF6110 Volvo Tracked Pavers Service Manual

Full Download: <https://www.arepairmanual.com/downloads/pf6110-volvo-tracked-pavers-service-manual/>

**V O L V O**

## Service Information

Document Title: <b>Delivery Inspection, according to Inspection Programme</b>	Function Group: <b>171</b>	Information Type: <b>Service Information</b>	Date: <b>5/2/2026</b>
Profile: <b>Tracked Pavers (PAT)</b>			

## Delivery Inspection, according to Inspection Programme

Op nbr 171-002

Total procedure time (hr): 1.75

1. This Inspection Programme can be found as a PDF file in the document library in PROSIS.

Sample manual. Download All 807 pages at:

<https://www.arepairmanual.com/downloads/pf6110-volvo-tracked-pavers-service-manual/>