



Document Title: Description	Function Group: 000	Information Type: Service Information	Date: 5/1/2026
Profile: P7920D Volvo PID:54715223			

Description

Showing Selected Profile

Valid for serial numbers			
Model	Production site	Serial number start	Serial number stop
P7920D Volvo PID:54715223			

The machine is designed for application of all types of graded asphalt aggregates, hydraulically bonded graded aggregates, graded ballast, sand or gravel.

The engine is a six-cylinder, four-stroke, in-line diesel engine with direct injection and water cooling.

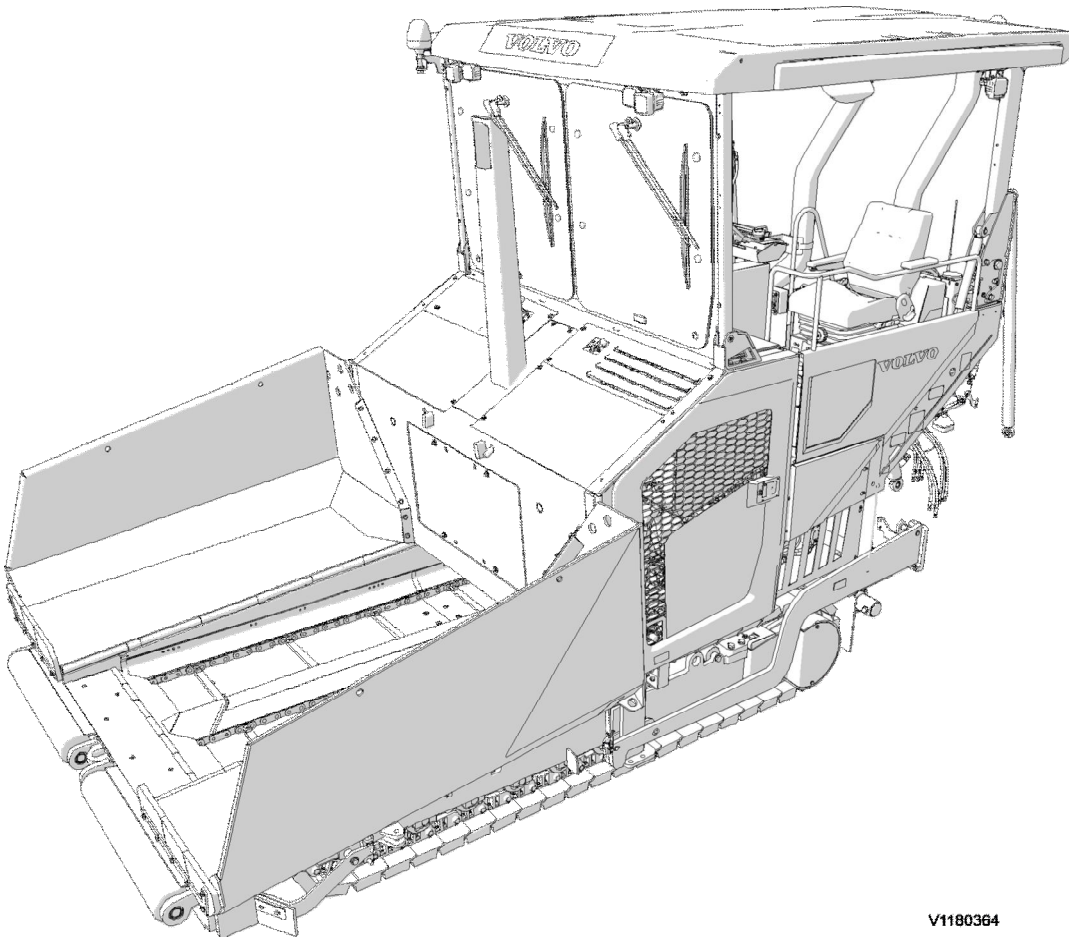

V1180364

Figure 1
General View

Document Title: Standard tightening torques	Function Group: 030	Information Type: Service Information	Date: 5/1/2026
Profile: P7920D Volvo PID:54715223			

Standard tightening torques

Showing Selected Profile

Valid for serial numbers			
Model	Production site	Serial number start	Serial number stop
P7920D Volvo PID:54715223			

Tightening torques in the following tables refer to bolted joints with tensile strength according to the below. The tables should be regarded as general guidelines for tightening bolted joints where nothing else is specified.

NOTE!

Increase the values by 10% for flange bolt type U6FS. Bolts and nuts should be clean and lubricated with oil.

Surface coating		Coefficient of friction	
Non-electrolytic zinc plate coatings	ISO10683-FLZN/ZN/TL/480	0.08	
	ISO10683-FLZN/ZN/TL/720		
	(ISO10683) Geomet 500A		
Yellowish iridescent	ISO4042-A2C	0.12	
Electrolytic coating	ASTMF 1941 Fe/Zn5ANS	0.24	

Dimension s	Strength classes	Coefficient of friction					
		0.08		0.12		0.24	
		Tightening torque (Nm)	Tightening torques: (lbf ft)	Tightening torque (Nm)	Tightening torques: (lbf ft)	Tightening torque (Nm)	Tightening torques: (lbf ft)
M4	8.8	2.3	1.7	3	2.21	3.8	2.8
	10.9	3.3	2.43	4.6	3.39	5.5	4.06
	12.9	3.9	2.87	5.1	3.76	6.5	4.79
M5	8.8	4.4	3.24	5.9	4.35	7.5	5.53
	10.9	6.5	4.79	8.6	6.34	11	8.11
	12.9	7.6	5.61	10	7.37	12.9	9.51
M6	8.8	7.7	5.67	10.1	7.44	13	9.59
	10.9	11.3	8.33	14.9	10.98	19.1	14.09
	12.9	13.2	9.73	17.4	12.83	22.3	16.45
M7	8.8	12.6	9.29	16.8	12.39	21.8	16.08
	10.9	18.5	13.64	24.7	18.21	32	23.6
	12.9	21.6	15.93	28.9	21.31	37.5	27.66
M8	8.8	18.5	13.64	24.6	18.14	31.7	23.38
	10.9	27.2	20.06	36.1	26.62	46.4	34.22
	12.9	31.8	23.45	42.2	31.12	54.4	40.12
M10	8.8	36	26.55	48	35.4	62.8	46.32
	10.9	53	39.09	71	52.36	92.3	68.08

Sample manual. Download All 1926 pages at:

<https://www.arepairmanual.com/downloads/p7920d-volvo-tracked-pavers-service-manual/>

M12	12.9	62	45.72	83	61.21	107	78.92
	8.8	63	46.46	84	61.95	108	79.66
	10.9	92	67.85	123	90.72	158.8	117.12
	12.9	108	79.65	144	106.20	185.5	136.82
M14	8.8	100	73.75	133	98.09	172.6	127.3
	10.9	146	107.68	195	143.82	252.9	186.53
	12.9	171	126.12	229	168.90	296.3	218.54
M16	8.8	153	112.84	206	151.93	268.6	198.11
	10.9	224	165.21	302	222.74	395.1	291.41
	12.9	262	193.24	354	261.09	462.5	341.12
M18	8.8	220	162.26	295	217.58	383.1	282.56
	10.9	314	231.59	421	310.51	546.5	403.08
	12.9	367	270.68	492	362.88	638.8	471.15
M20	8.8	308	227.16	415	306.08	542.8	400.35
	10.9	438	323.05	592	436.63	773.5	570.5
	12.9	513	378.36	692	510.39	904.6	667.2
M22	8.8	417	307.56	567	418.19	745.8	550.07
	10.9	595	438.84	807	595.21	1062.5	783.66
	12.9	696	513.34	945	696.99	1243.4	917.08
M24	8.8	529	390.17	714	526.61	933.2	688.29
	10.9	754	556.12	1017	750.1	1329.2	980.37
	12.9	882	650.52	1190	877.69	1555.4	1147.2
M27	8.8	772	569.39	1050	774.44	1382.8	1019.9
	10.9	1100	811.31	1496	1103.39	1969.8	1452.85
	12.9	1287	949.24	1750	1290.73	2304.9	1700
M30	8.8	1053	776.65	1428	1053.23	2090.8	1542.09
	10.9	1500	1106.34	2033	1499.46	2670.5	1969.66
	12.9	1755	1294.42	2380	1755.39	3125.5	2305.25

UNC threads, coarse pitch	Nm	lbf ft
1/4"	9 ±2	6.6 ±1.5
5/16"	18 ±4	13 ±3.0
3/8"	33 ±8	24 ±5.9
7/16"	54 ±14	40 ±10
1/2"	80 ±20	59 ±15
9/16"	120 ±30	89 ±22
5/8"	170 ±40	130 ±30
3/4"	300 ±70	220 ±52
7/8"	485 ±115	360 ±85
1"	725 ±175	530 ±130

Document Title: Volvo standard tightening torques	Function Group: 030	Information Type: Service Information	Date: 5/1/2026
Profile: P7920D Volvo PID:54715223			

Volvo standard tightening torques

Showing Selected Profile

Valid for serial numbers			
Model	Production site	Serial number start	Serial number stop
P7920D Volvo PID:54715223			

Tightening torques in the following tables refer to bolted joints with tensile strength according to the below. The tables should be regarded as general guidelines for tightening bolted joints where nothing else is specified.

NOTE!

Increase the values by 10% for flange bolt type U6FS. Bolts and nuts should be clean and lubricated with oil.

Metric coarse and fine threads, tensile strength class 8.8	Nm	kpm	lbf ft
M6	10 ±2	1,0 ±0,2	7,4 ±1,5
M8	24 ±5	2,4 ±0,5	18 ±3,5
M10	48 ±10	4,8 ±1,0	35 ±7,4
M12	85 ±18	8,5 ±1,8	63 ±13
M14	140 ±25	14,0 ±2,5	103 ±18
M16	220 ±45	22,0 ±4,5	160 ±33
M20	430 ±85	43,0 ±8,5	320 ±63
M24	740 ±150	74,0 ±15,0	550 ±110

Metric coarse and fine threads, tensile strength class 10.9	Nm	kpm	lbf ft
M6	12 ±2	1,2 ±0,2	9 ±1,5
M8	30 ±5	3,0 ±0,5	22 ±3,5
M10	60 ±10	6,0 ±1,0	44 ±7,4
M12	105 ±20	10,5 ±2,0	78 ±14,5
M14	175 ±30	17,5 ±3,0	130 ±22
M16	275 ±45	27,5 ±4,5	204 ±33
M20	540 ±90	54,0 ±9,0	400 ±66
M24	805 ±160	80,5 ±16,0	594 ±118

UNC-threads, coarse pitch	Nm	kpm	lbf ft
1/4"	9 ±2	0,9 ±0,2	6,6 ±1,5
5/16"	18 ±4	1,8 ±0,4	13 ±3,0
3/8"	33 ±8	3,3 ±0,8	24 ±5,9
7/16"	54 ±14	5,4 ±1,4	40 ±10

1/2"	80 ±20	8,0 ±2,0	59 ±15
9/16"	120 ±30	12,0 ±3,0	89 ±22
5/8"	170 ±40	17,0 ±4,0	130 ±30
3/4"	300 ±70	30,0 ±7,0	220 ±52
7/8"	485 ±115	48,5 ±11,5	360 ±85
1"	725 ±175	72,5 ±17,5	530 ±130

Document Title: Component locations	Function Group: 030	Information Type: Service Information	Date: 5/1/2026
Profile: P7920D Volvo PID:54715223			

Component locations

Showing Selected Profile

Valid for serial numbers			
Model	Production site	Serial number start	Serial number stop
P7920D Volvo PID:54715223			

Main components

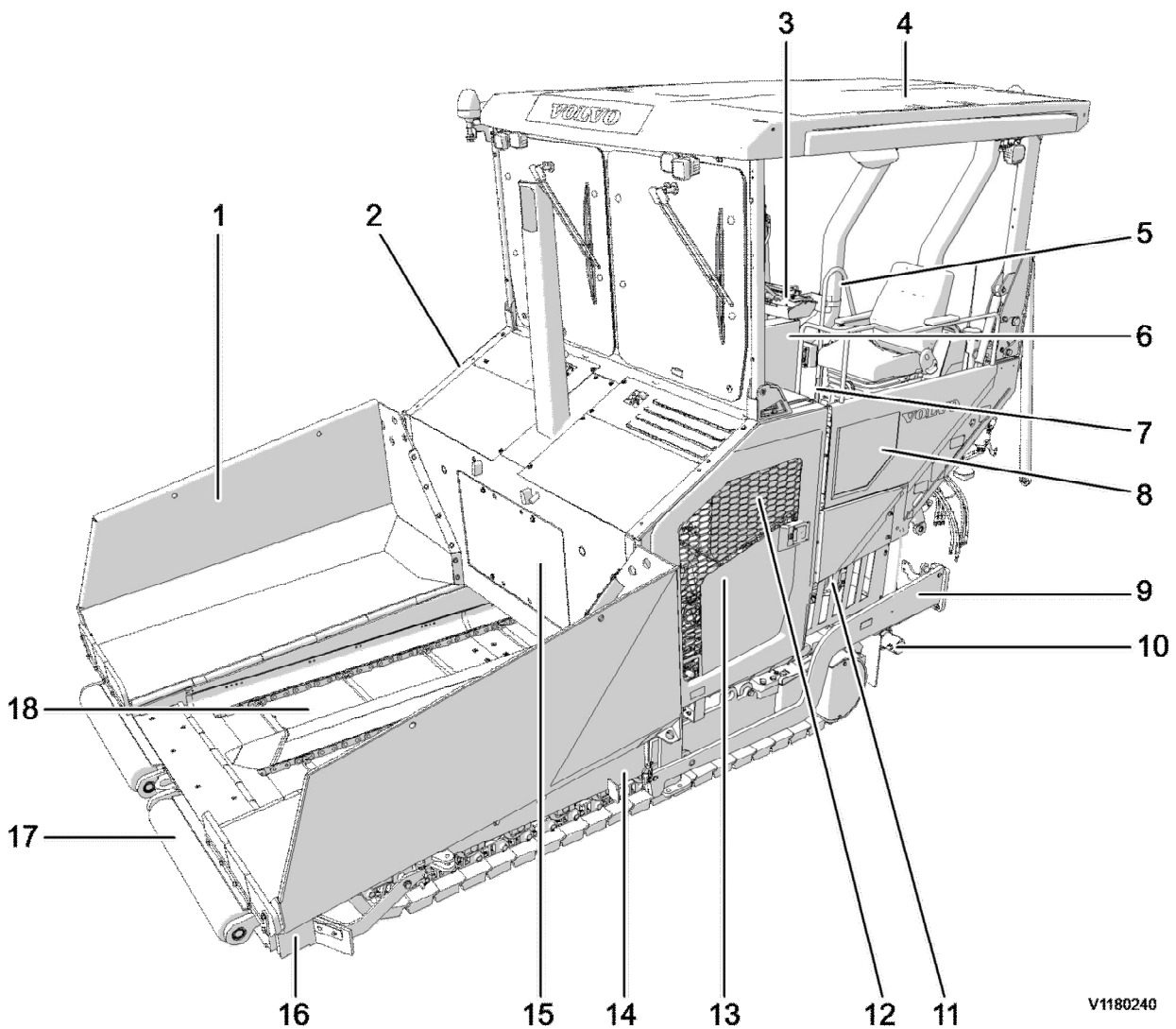

V1180240

Figure 1
Main components

Position	Description	Position	Description	Position	Description

1	Hopper		7	Operator's platform		13	Engine Pump gearbox
2	Cooler		8	Extendable operator's platform		14	Track unit
3	Main control unit		9	Towing arms		15	Exhaust aftertreatment system
4	All-weather roof		10	Auger		16	Frame
5	Ascent		11	Fuel tank		17	Push rollers
6	Electrical		12	Hydraulic oil tank		18	Conveyor

Maintenance hatches

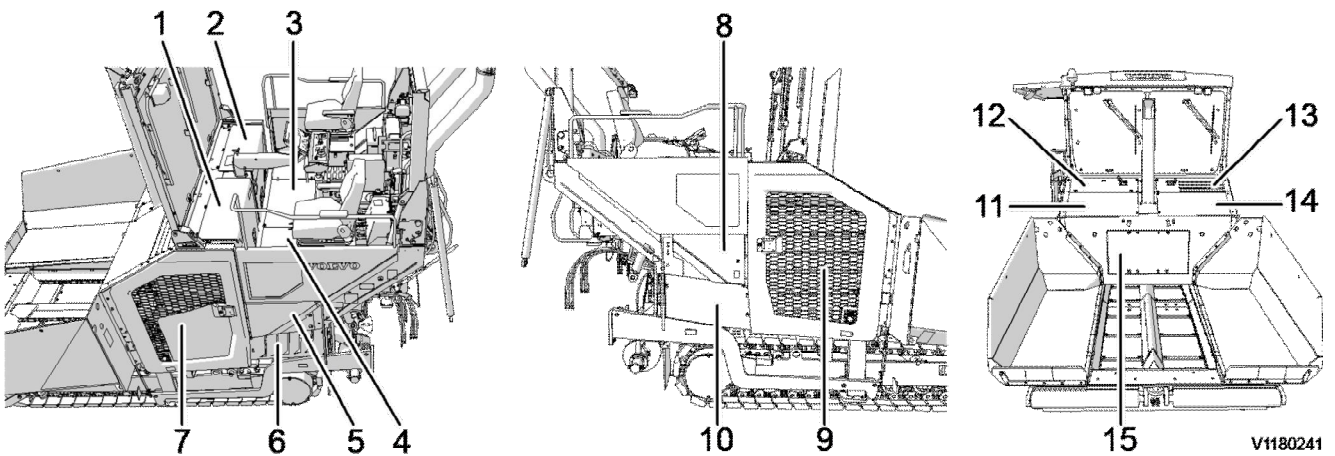

Figure 2
Maintenance hatches

Position	Description		Position	Description		Position	Description
1	Left engine hood		6	Lower left protective plate		11	Right deck plate next to the exhaust pipe
2	Right engine hood		7	Left service door		12	Upper right protective plate
3	Right floor service hatch		8	Deck plate right		13	Upper left protective plate
4	Left service hatch		9	Right service door		14	Lower left protective plate
5	Upper left protective plate		10	Protective plate right		15	Deck plate in hopper.

Document Title: Machine weights	Function Group: 030	Information Type: Service Information	Date: 5/1/2026
Profile: P7920D Volvo PID:54715223			

Machine weights

Showing Selected Profile

Valid for serial numbers			
Model	Production site	Serial number start	Serial number stop
P7920D Volvo PID:54715223			

Machine weight	14320 kg (31570 lbs)
Machine weight (with balancing weight)	14470 kg (31900 lbs)

The machine weight is stated under the following conditions:

- Without screed
- With Standard hopper
- With standard push roller
- With generator
- Fuel tank half full
- Operator's weight 75 kg (165.35 lbs)

Document Title: Dimensions	Function Group: 030	Information Type: Service Information	Date: 5/1/2026
Profile: P7920D Volvo PID:54715223			

Dimensions

Showing Selected Profile

Valid for serial numbers			
Model	Production site	Serial number start	Serial number stop
P7920D Volvo PID:54715223			

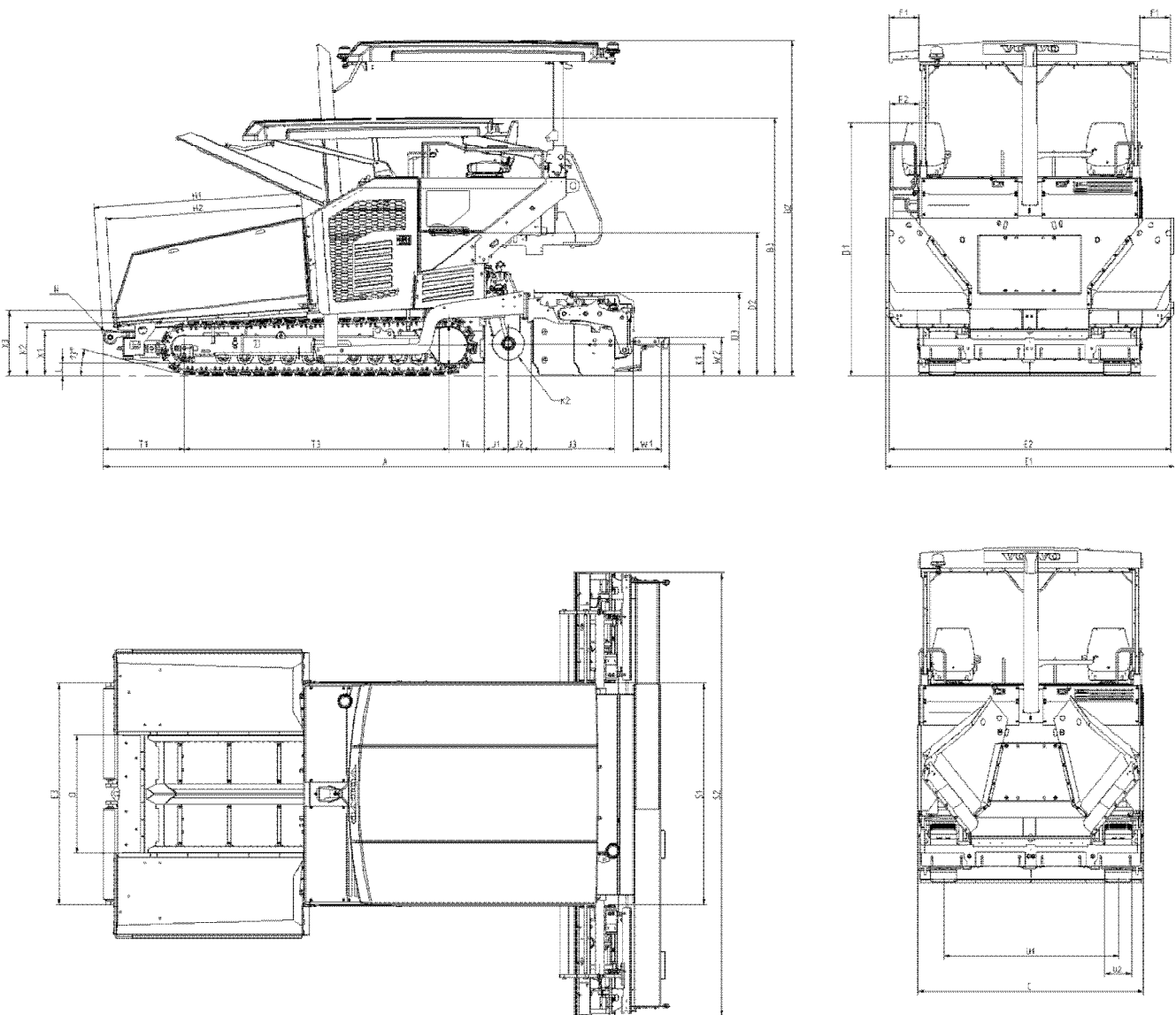

V1224076

Figure 1
Dimensions, drawing

Pos.	Unit	Dimension	Designation	Remark
------	------	-----------	-------------	--------

A	mm	6387	Operating length	with walkway down
B1	mm	—	Operating height	see B2
B2	mm	3784	Height weather roof	
B3	mm	2916	Shipping height	weather roof down
C	mm	2548	Tractor width	transport width
D1	mm	2874	Height seat backrest	
D2	mm	1614	Deck height	height of platform to ground
D3	mm	936	Screed platform height	
E1	mm	3255	Outer hopper width	
E2	mm	3175	Inner hopper width	
E3	mm	2495	Width push roller	
F1	mm	770	Extension weather roof	
F2	mm	337	Seat console extension	
X1	mm	515	Inner Loading height	conveyor area
X2	mm	599	Loading height hopper	without rubber mat
X3	mm	734	Loading height hopper	with rubber mat
H1	mm	2342	Feeding length	distance from rear wall to front of push roller
H2	mm	2219	Hopper length	
J1	mm	275	Distance rear wall — auger centre	
J2	mm	259	Distance auger centre —screed	
J3	mm	932	Screed depth	
K1	mm	360	Auger height	auger center — ground; height adjustment $\pm 65\text{mm}$
K2	mm	360	Diameter auger	
L	mm	155	Ground clearance	
N	mm	160	Diameter push roller	
O	mm	1325	Conveyor width	
S1	m	2.5	Basic screed width VB78	without end gates
	m	3.0	Basic screed width VB88	
S2	m	5.0	Extended screed width VB78	without end gates
	m	6.0	Extended screed width VB88	
T1	mm	918	Track front to push roller	
T3	mm	2984	Track length	centre track tensioner — centre track drive
T4	mm	398	Track distance to rear wall	centre track drive — rear wall
U1	mm	1974	Track gauge	
U2	mm	302	Track pad width	
W1	mm	315	Width of walkway	
W2	mm	435	Height of walkway	distance to ground, screed down

Document Title: Conversion tables	Function Group: 030	Information Type: Service Information	Date: 5/1/2026
Profile: P7920D Volvo PID:54715223			

Conversion tables

Showing Selected Profile

Valid for serial numbers			
Model	Production site	Serial number start	Serial number stop
P7920D Volvo PID:54715223			

Length

Unit	cm	m	km	in	ft	yd	mile
cm	1	0.01	0.00001	0.3937	0.03281	0.01094	0.000006
m	100	1	0.001	39.37	3.2808	1.0936	0.00062
km	100000	1000	1	39370.7	3280.8	1093.6	0.62137
in	2.54	0.0254	0.000025	1	0.08333	0.02777	0.000015
ft	30.48	0.3048	0.000304	12	1	0.3333	0.000189
yd	91.44	0.9144	0.000914	36	3	1	0.000568
mile	160930	1609.3	1.6093	63360	5280	1760	1

1 mm = 0.1 cm - 1 mm = 0.001 m

Area

Unit	cm ²	m ²	km ²	a	ft ²	yd ²	in ²
cm ²	1	0.0001	-	0.000001	0.001076	0.000012	0.155000
m ²	10000	1	0.000001	0.01	10.764	1.1958	1550.000
km ²	-	1000000	1	10000	1076400	1195800	-
a	0.01	100	0.0001	1	1076.4	119.58	-
ft ²	-	0.092903	-	0.000929	1	0.1111	144.000
yd ²	-	0.83613	-	0.008361	9	1	1296.00
in ²	6.4516	0.000645	-	-	0.006943	0.000771	1

1 ha = 100 a - 1 mile² = 259 ha = 2.59 km²

Volume

Unit	cm ³ = cc	m ³	l	in ³	ft ³	yd ³
cm ³ = ml	1	0.000001	0.001	0.061024	0.000035	0.000001
m ³	1000000	1	1000	61024	35.315	1.30796
dm ³ (l)	1000	0.001	1	61.024	0.035315	0.001308
in ³	16.387	0.000016	0.01638	1	0.000578	0.000021
ft ³	28316.8	0.028317	28.317	1728	1	0.03704
yd ³	764529.8	0.76453	764.53	46656	27	1

1 gal (US) = 3785.41 cm³ = 231 in³ = 0.83267 gal (UK)

Weight

Unit	g	kg	t	oz	lb
g	1	0.001	0.000001	0.03527	0.0022
kg	1000	1	0.001	35.273	2.20459
t	1000000	1000	1	35273	2204.59
oz	28.3495	0.02835	0.000028	1	0.0625
lb	453.592	0.45359	0.000454	16	1

1 ton (metric) = 1.1023 ton (US) = 0.9842 ton (UK)

Pressure

Unit	kp/cm ²	bar	Pa=N/m ²	kPa	lbf/in ²	lbf/ft ²
kp/cm ²	1	0.98067	98066.5	98.0665	14.2233	2048.16
bar	1.01972	1	100000	100	14.5037	2088.6
Pa=N/m ²	0.00001	0.001	1	0.001	0.00015	0.02086
kPa	0.01020	0.01	1000	1	0.14504	20.886
lbf/in ²	0.07032	0.0689	6894.76	6.89476	1	144
lbf/ft ²	0.00047	0.00047	47.88028	0.04788	0.00694	1

kg/cm² = 735.56 Dry (mmHg) = 0.96784 atm

Unit explanations

Unit	abbreviation
Newton meter	Nm
Kilopoundmeter	kpm
Kilopascal	kPa
Megapascal	MPa
Kilowatt	kW
kilojoule	kJ
British thermal unit	Btu
Calorie	cal

Approx. conversion

SI unit	Conversion factor	Non SI	Conversion factor	SI
Torque				
Nm	x10.2	=kg/cm	x0.8664	=lb in
Nm	x0.74	=lbf-ft	x1.36	=Nm
Nm	x0.102	=kg/m	x7.22	=lbft
Pressure (Pa = N/m²)				
kPa	x4.0	=in.H ₂ O	x0.249	=kPa
kPa	x0.30	=in.Hg	x3.38	=kPa
kPa	x0.145	=psi	x6.89	=kPa
bar	x14.5	=psi	x0.069	=bar
kp/cm ²	x14.22	=psi	x0.070	=kp/cm ²
N/mm ²	x145.04	=psi	x0.069	=bar
MPa	x145	=psi	x0.00689	=MPa
Power (W = J/s)				
kW	x1.36	=hp(cv)	x0.736	=kW

kW	x1.34	= bhp	x0.746	= kW
kW	x0.948	= Btu/s	x1.055	= kW
W	x0.74	= ft-lb/s	x1.36	= W
Energy (J = Nm)				
kJ	x0.948	= Btu	x1.055	= kJ
J	x0.239	= calorie	x4.19	= J
Speed and acceleration				
m/s ²	x3.28	= ft/s ²	x0.305	= m/s ²
m/s	x3.28	= ft/s	x0.305	= m/s
km/h	x0.62	= mph	x1.61	= km/h
Horsepower/torque				
Bhp x5252 rpm = TQ (lb-ft)			TQ x rpm 5252 = bhp	
Temperature				
°C = (°F - 32) / 1.8			°F = (°C x 1.8) + 32	
Flow factor				
l/min (dm ³ /min)	x0.264	= US gal/min	x3.785	= liter/min

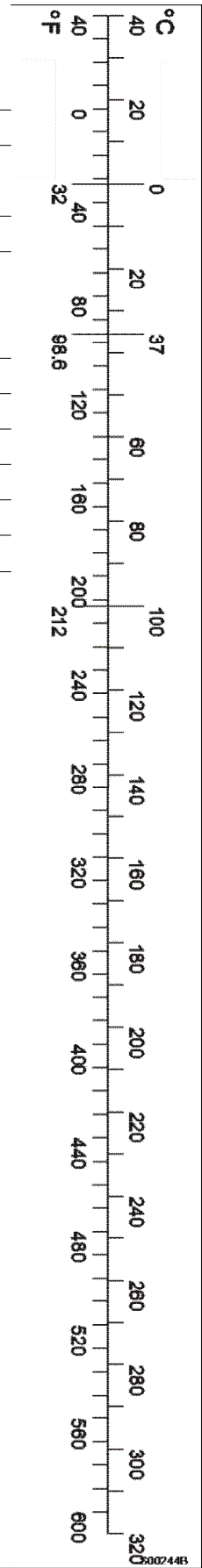

Document Title: Loading	Function Group: 050	Information Type: Service Information	Date: 5/1/2026
Profile: P7920D Volvo PID:54715223			

Loading

Showing Selected Profile

Valid for serial numbers			
Model	Production site	Serial number start	Serial number stop
P7920D Volvo PID:54715223			

Transport data

The given instructions for loading and securing the loaded machine are only valid if the following conditions are fulfilled:

Maximum machine weight		230,000 N
Factor longitudinal to driving direction	Braking	0.8 (0.8)
	Accelerating	0.5 (0.5)
	Driving in curves	0.5 (0.5)
Friction angle γ (Steel with rubber)		24 ° (24°)
Friction coefficient μ		0.45 (0.45)
Loading platform surface		Wood or metal No oil — No ice — No soil — No mud

Load handling attachments and slings according to standard	EN 12195
Chain lashing capacity	10000 daN
Appropriate slings	textile lashing belt with protective cover or edging strip
Standard chain tension force for one chain	depending on towing method, page Tying down machine

Document Title: Tying down machine	Function Group: 050	Information Type: Service Information	Date: 5/1/2026
Profile: P7920D Volvo PID:54715223			

Tying down machine

Showing Selected Profile

Valid for serial numbers			
Model	Production site	Serial number start	Serial number stop
P7920D Volvo PID:54715223			

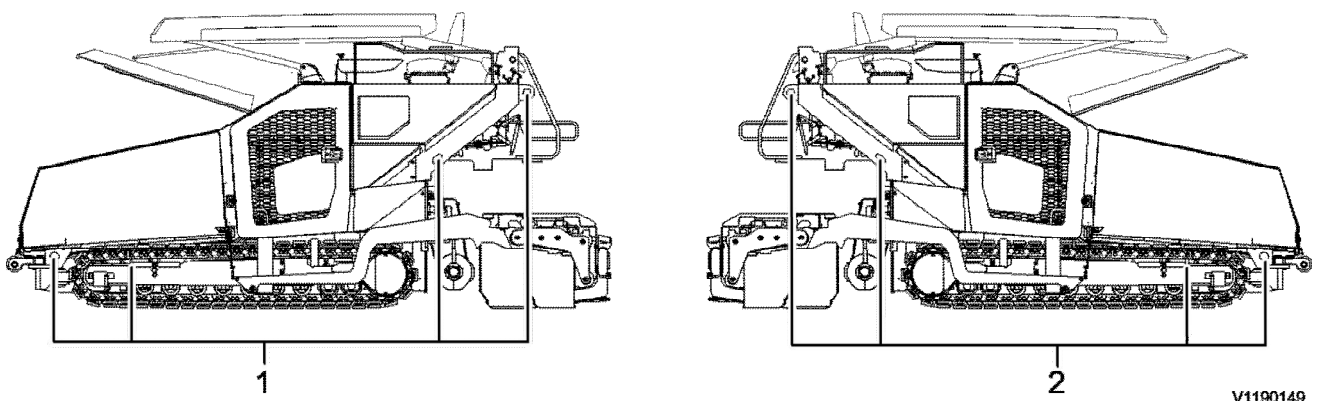

V1190149

Figure 1

Lashing points

1. Machine lashing points, left
 2. Machine lashing points, right
1. From the following lashing methods, select the one that is best suited to your situation.
 2. Select suitable load handling attachments, see also page [Loading](#).
 3. Lash the machine according to the lashing method selected so that the machine cannot tip over or roll away. The positions of all lashing eyes and lifting points can be found on page [International decals](#).

Lashing method 1

APPLY Chain tension STF	min. 400 daN
--------------------------------	---------------------

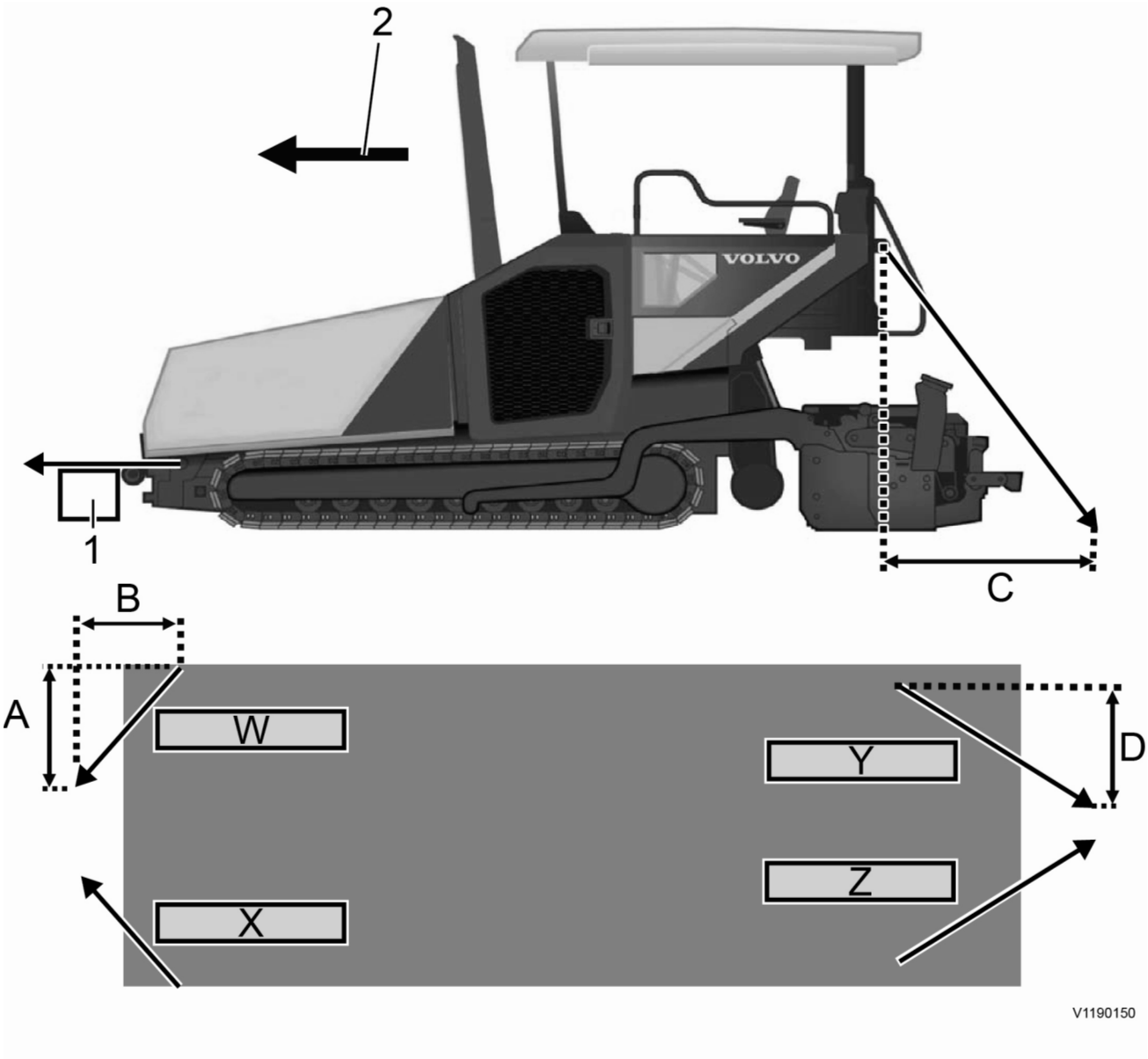

V1190150

Figure 2
Lashing method 1

1. Stop (fixed to low loader), recommended
2. Loading direction

Lashing method 1

Distance between lashing point and projected tie-down point		Standard Tension Force (STF)	
A	0.3 m - 2.8 m (1 ft - 9,2 ft)	W	Min. 400 daN
B	1.3 m - 3 m (4,3 ft - 9,9 ft)	X	
C	1.3 m - 3 m (4,3 ft - 9,9 ft)	Y	
D	0.5 m - 2.8 m (1,7 ft - 9,2 ft)	Z	

Lashing method 2

APPLY Chain tension STF W/X	min. 400 daN
APPLY Chain tension STF Y/Z	min. 2800 daN

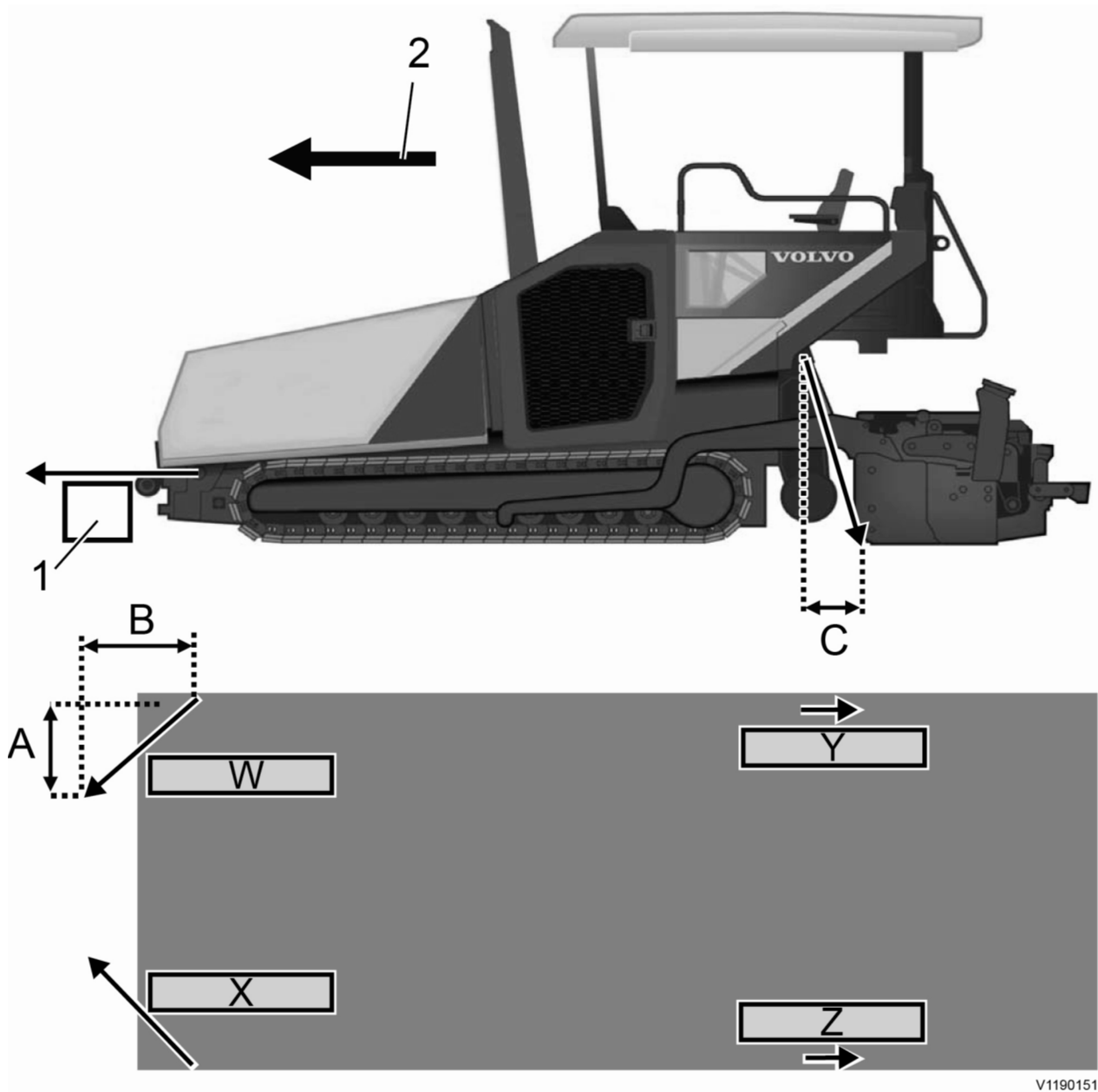

V1190151

Figure 3
Lashing method 2

- 1. Stop (fixed to low loader), recommended
- 2. Loading direction

Lashing method 2

Distance between lashing point and projected tie-down point		Standard Tension Force (STF)	
A	0.3 m - 2.8 m (1 ft - 9,2 ft)	W	400 daN
B	1.3 m - 3 m (4,3 ft - 9,9 ft)	X	
C	0 m - 0.4 m (0 ft - 1,3 ft)	Y	2800 daN
		Z	

Lashing method 3

APPLY Chain tension STF	min. 2800 daN
--------------------------------	----------------------

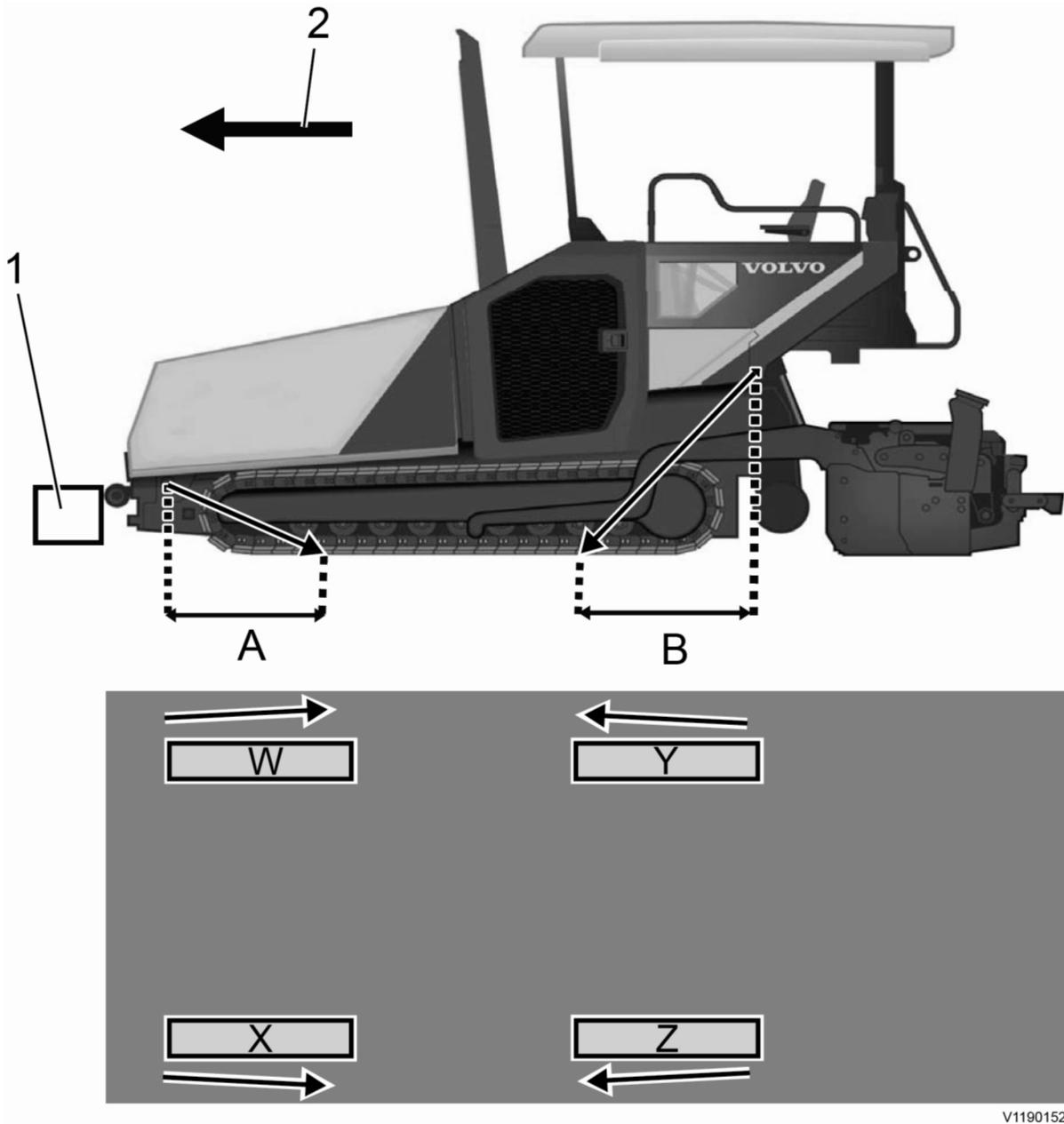

V1190152

Figure 4

Lashing method 3

1. Stop (fixed to low loader), recommended
2. Loading direction

Lashing method 3

Distance between lashing point and projected tie-down point		Standard Tension Force (STF)	
A	0.2 m - 1 m (0,7 ft - 3,3 ft)	W	2800 daN
		X	
B	0 m - 1.8 m (0 ft - 5,9 ft)	Y	
		Z	

Lashing method 4

APPLY Chain tension STF	min. 2800 daN
--------------------------------	----------------------

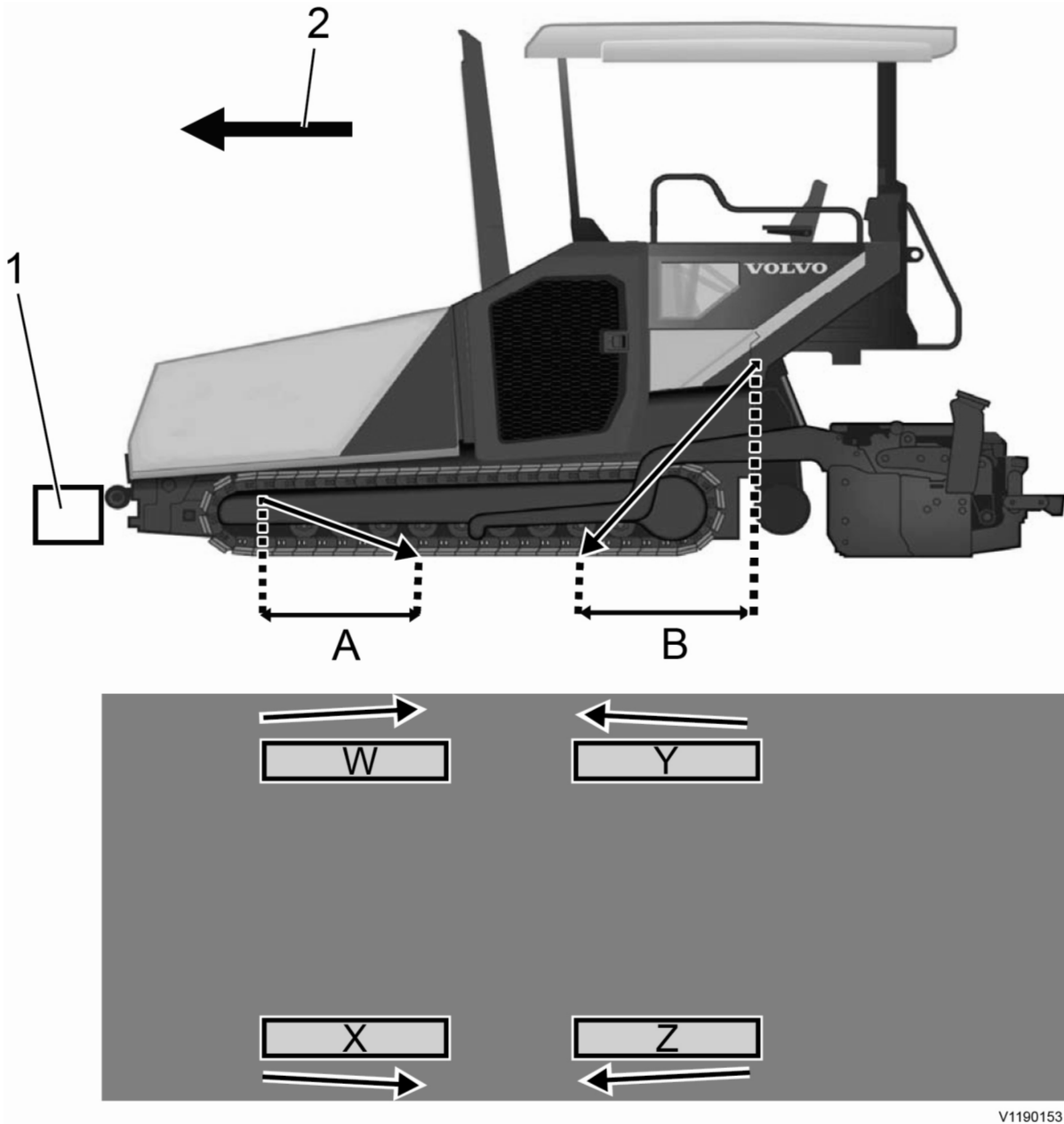

V1190153

Figure 5

Lashing method 4

1. Stop (fixed to low loader), recommended
2. Loading direction

Lashing method 4

Distance between lashing point and projected tie-down point		Standard Tension Force (STF)	
A	0.2 m - 1 m (0,7 ft - 3,3 ft)	W	2800 daN
		X	
B	0 m - 1.8 m (0 ft - 5,9 ft)	Y	
		Z	

Document Title: Transporting the machine under its own power	Function Group: 050	Information Type: Service Information	Date: 5/1/2026
Profile: P7920D Volvo PID:54715223			

Transporting the machine under its own power

Showing Selected Profile

Valid for serial numbers			
Model	Production site	Serial number start	Serial number stop
P7920D Volvo PID:54715223			



WARNING

Risk of serious injury.

The machine could tilt while loading on to or unloading from the transporter. Tilting of the machine will cause the operator to fall off which could result in serious injury.

Ensure to approach the loading ramps squarely. Always use a signal person to assist while loading or unloading the machine.

1. Remove all loose objects from the machine.
2. Raise the augers to their highest position.
3. Fold up the road scrapers and make sure they are locked in place.
4. Close and lock the hopper.
5. Lock the direction indicator.
6. Remove gas cylinders if the screed is fitted with gas heating system.
7. Remove all screed attachments, see the operator's manual for the screed.
8. Lock the swivelling arms.
9. Raise the screed into transport position and lock the screed transport lock.
10. Secure and mark the machine in accordance with local regulations.

Document Title: Loading the machine under its own power	Function Group: 050	Information Type: Service Information	Date: 5/1/2026
Profile: P7920D Volvo PID:54715223			

Loading the machine under its own power

Showing Selected Profile

Valid for serial numbers			
Model	Production site	Serial number start	Serial number stop
P7920D Volvo PID:54715223			



Risk of serious injury.

The machine could tilt while loading on to or unloading from the transporter. Tilting of the machine will cause the operator to fall off which could result in serious injury.

Ensure to approach the loading ramps squarely. Always use a signal person to assist while loading or unloading the machine.

1. Choose a level and firm area where the transport vehicle can stand safely.
2. Clean the transport platform and loading ramps.
3. Remove the gas cylinders, if the screed is fitted with gas heating system.
4. Move the auger to the top position.
5. Fully raise the screed and then retract it.
6. Secure the transport vehicle against rolling.
7. Accept the help of a second person.
8. Start the engine.
9. Drive straight onto the loading ramps of the transport vehicle so that the machine cannot slip sideways from the ramp.
10. Drive the machine straight onto the transport vehicle.
11. Lower the screed to the loading platform of the transport vehicle.
12. Switch off the engine.
13. Remove the paving panel and screed panels and stow them in the storage compartment provided for this purpose.
14. Secure the driving panel against vandalism.
15. Close the front windshield.
16. Lower the all-weather roof.
17. Switch off the battery disconnect switch.
18. Secure the machine onto the transport vehicle.

Document Title: Loading the machine with crane	Function Group: 050	Information Type: Service Information	Date: 5/1/2026
Profile: P7920D Volvo PID:54715223			

Loading the machine with crane

Showing Selected Profile

Valid for serial numbers			
Model	Production site	Serial number start	Serial number stop
P7920D Volvo PID:54715223			



Risk of crushing.

A suspended machine could fall. A falling machine will cause fatal injury to persons below.

Never step under a suspended machine.

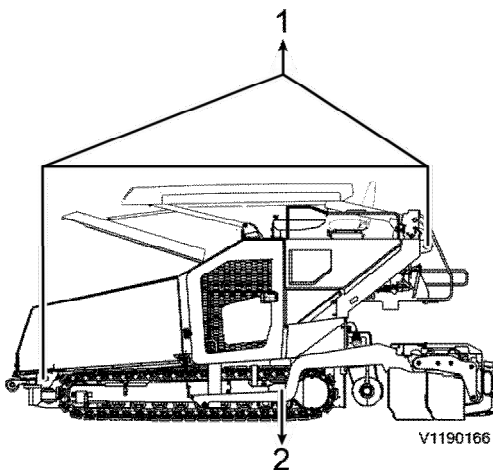

Figure 1

Loading with a crane

1. Suspension point
2. Centre of gravity



Figure 2

Point for lifting

1. Select an even, firm base on which the transport vehicle and crane can stand securely.
2. Select the crane, transport vehicle and lifting tool according to the weight of the machine and the lifting conditions.
3. Remove the screed end plates and all screed attachments, see the operator's manual for the screed.
4. Start the engine.

5. Lower the screed to the ground.
6. Close and lock the hopper.
7. Stop the engine.
8. If the screed is equipped with a gas heating system, remove the gas cylinders.
9. Remove and stow the paving panel and screed panels.
10. Secure the driving panel to prevent vandalism.
11. Remove all loose objects from the machine.
12. Lower the all-weather roof. Lock the all-weather roof support.
13. Switch off the battery disconnect switch.
14. Position the crane with traverse close to the machine.
Get a second person to help when positioning the crane and loading the machine.
15. **Use a traverse.**
Attach the lifting slings to the lifting points marked with the "Lifting point" decal.
16. Balance the machine around its the centre of gravity (2).
17. After attaching the lifting slings, the suspension point (1) of the load must be brought into the vertical position above the centre of gravity of the machine.
The centre of gravity (2) is dependent on the screed fitted. In principle, the centre of gravity of the machine with the screed fitted is between the 1st and 2nd rollers in front of the drive gear sprocket of the travelling gear.
18. Safely lash the machine on the transport vehicle.

Document Title: Operation numbers for additional work	Function Group: 070	Information Type: Service Information	Date: 5/1/2026
Profile: Tracked Pavers (PAT)			

Operation numbers for additional work

Showing Selected Profile

These operations can be used to identify work that is not included in the time guide or described in the methods in the Service Manual. When these operations are used, a description of the work that has been performed must be provided.

Other work related to engine

Op. no. 070-210

This operation can be used when work has been done related to the engine and function group 2 when no applicable method description was available. When this operation is used, additional information is required:

- Description of work that has been done

Other work related to electrical system

Op. no. 070-310

This operation can be used when work has been done related to the electrical system and function group 3 when no applicable method description was available. When this operation is used, additional information is required:

- Description of work that has been done

Other work related to transmission, gearbox, travel motor, swing motor

Op. no. 070-410

This operation can be used when work has been done related to the transmission, gearbox, travel motor or swing motor and function group 4 when no applicable method description was available. When this operation is used, additional information is required:

- Description of work that has been done

Other work related to drive axle

Op. no. 070-470

This operation can be used when work has been done related to the drive axle and function group 46 when no applicable method description was available. When this operation is used, additional information is required:

- Description of required work that have been done

Other work related to brake system

Op. no. 070-510

This operation can be used when work has been done related to the brake system and function group 5 when no applicable

method description was available. When this operation is used, additional information is required:

- Description of work that has been done

Other work related to steering system

Op. no. 070-610

This operation can be used when work has been done related to the steering system and function group 6 when no applicable method description was available. When this operation is used, additional information is required:

- Description of work that has been done

Other work related to frame link, axle suspension

Op. no. 070-710

This operation can be used when work has been done related to the frame link, axle suspension and other parts related to function group 7 when no applicable method description was available. When this operation is used, additional information is required:

- Description of work that has been done

Other work related to cab, air conditioning

Op. no. 070-810

This operation can be used when work has been done related to the cab, air conditioning and other parts related to function group 8 when no applicable method description was available. When this operation is used, additional information is required:

- Description of work that has been done

Other work related to hydraulic system

Op. no. 070-910

This operation can be used when work has been done related to the hydraulic system and other parts related to function group 9 when no applicable method description was available. When this operation is used, additional information is required:

- Description of work that has been done

Document Title: E-2030	Function Group: 080	Information Type: Service Information	Date: 5/1/2026
Profile: P7920D Volvo PID:54715223			

E-2030

Showing Selected Profile

Valid for serial numbers			
Model	Production site	Serial number start	Serial number stop
P7920D Volvo PID:54715223			

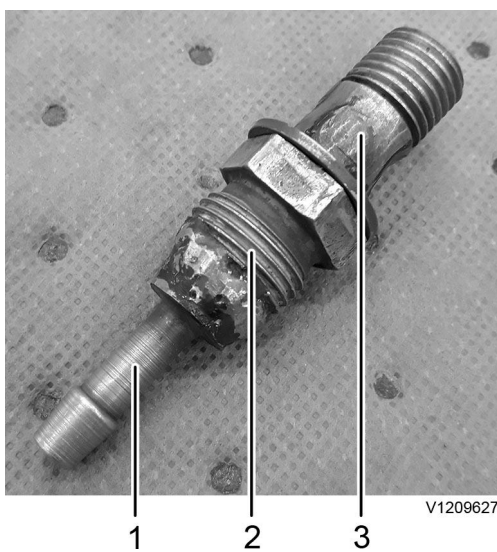

Figure 1

1. Hose nipple, diameter of approx. 8 mm
2. 21023622
3. Holes welded shut

Document Title: E-2032	Function Group: 080	Information Type: Service Information	Date: 5/1/2026
Profile: P7920D Volvo PID:54715223			

E-2032

Showing Selected Profile

Valid for serial numbers			
Model	Production site	Serial number start	Serial number stop
P7920D Volvo PID:54715223			



Figure 1

1. 995895
2. Washers (2 pcs)

Document Title: E-7006	Function Group: 080	Information Type: Service Information	Date: 5/1/2026
Profile: P7920D Volvo PID:54715223			

E-7006

Showing Selected Profile

Valid for serial numbers			
Model	Production site	Serial number start	Serial number stop
P7920D Volvo PID:54715223			

All dimensions in mm.

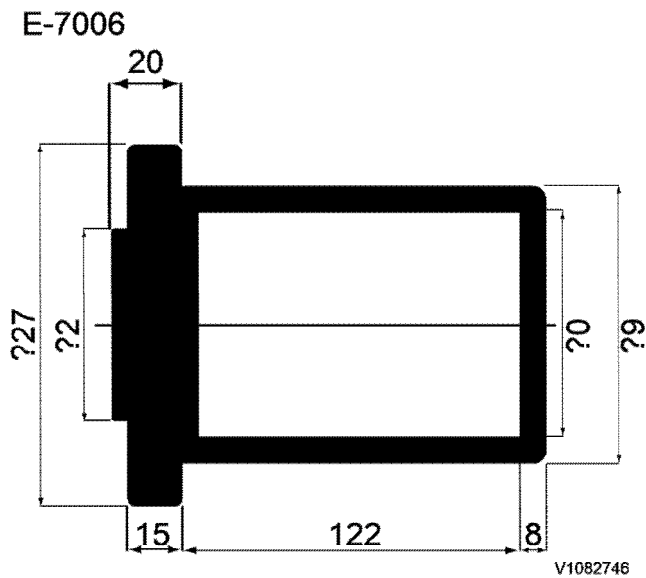

Figure 1

E-7006 Drift

Material: S355 JR or better.

Document Title: E-7008	Function Group: 080	Information Type: Service Information	Date: 5/1/2026
Profile: P7920D Volvo PID:54715223			

E-7008

Showing Selected Profile

Valid for serial numbers			
Model	Production site	Serial number start	Serial number stop
P7920D Volvo PID:54715223			

All dimensions in mm.

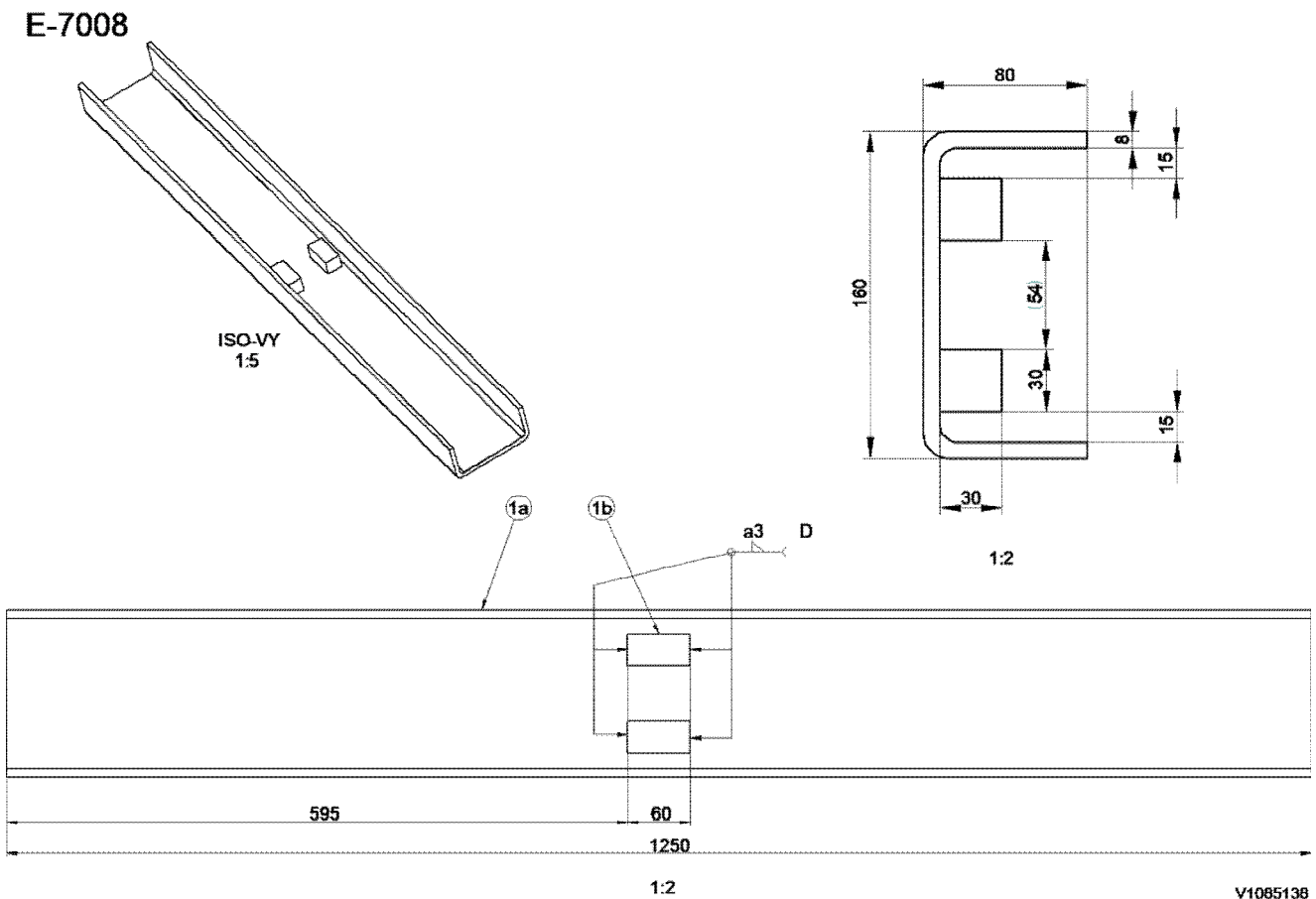

Figure 1

E-7008 U bar

Material: S355 JR or better.

Document Title: E-7009	Function Group: 080	Information Type: Service Information	Date: 5/1/2026
Profile: P7920D Volvo PID:54715223			

E-7009

Showing Selected Profile

Valid for serial numbers			
Model	Production site	Serial number start	Serial number stop
P7920D Volvo PID:54715223			

All dimensions in mm.

E-7009

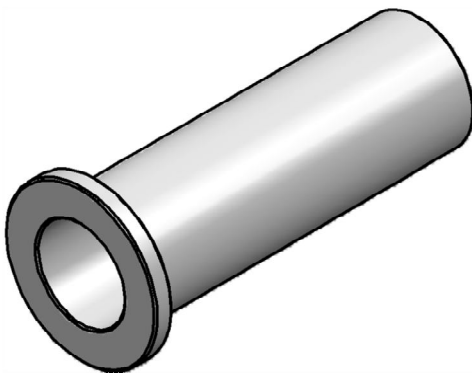
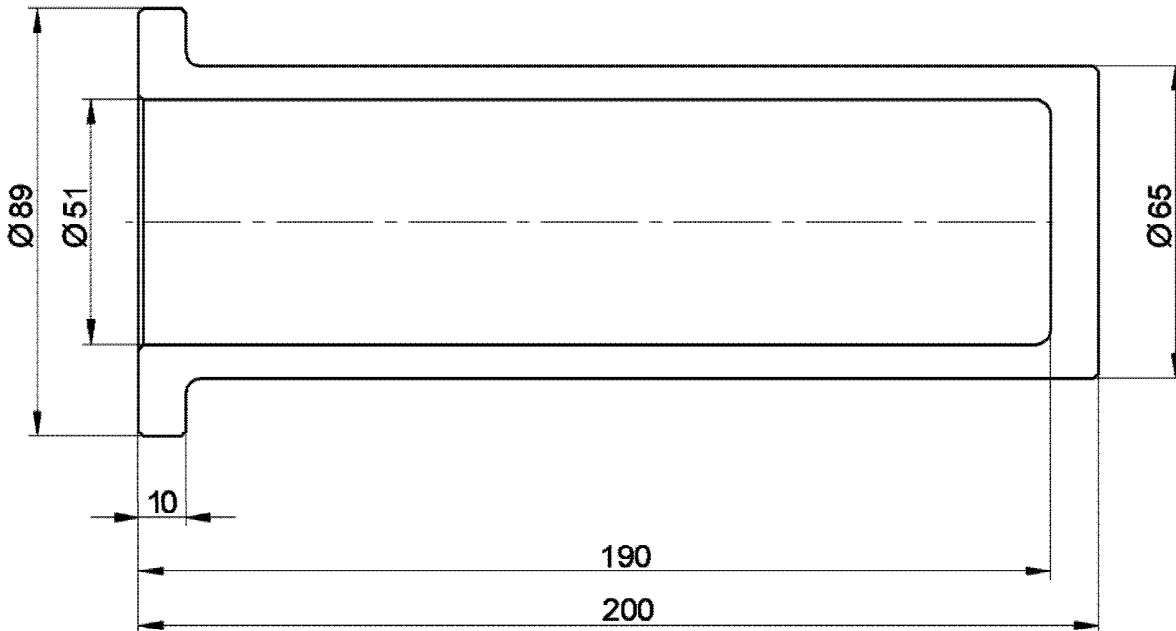

V1086432

Figure 1

E-7009 Drift

Material: S355 JR or better.

Sample manual. Download All 1926 pages at:

<https://www.arepairmanual.com/downloads/p7920d-volvo-tracked-pavers-service-manual/>