

Document Title: Tightening torques	Function Group: 030	Information Type: Service Information	Date: 5/1/2026
Profile: P7110B Volvo			

[Go back to Index Page](#)

Tightening torque, specifications

Showing Selected Profile

Valid for serial numbers			
Model	Production site	Serial number start	Serial number stop
P7110B Volvo			

ISO Metric Torque chart

Use the following recommended torque chart for bolts and nuts of ISO Metric strength Class 8.8 or better. If other torques are required, they will be indicated in the text

Bolt Size	Torque	
	Nm	lbf ft
M6 x 1,0	12	9
M8 x 1,25	28	21
M10 x 1,5	61	45
M12 x 1,75	105	79
M14 x 2,0	170	125
M16 x 2,0	265	195
M20 x 2,5	515	380
M24 x 3,0	895	660
M30 x 3,5	1780	1310
M36 x 4,0	3100	2290
M42 x 3,5	4960	3660

NOTE!

Use High Strength thread locking compound on all bolts larger than M8.

NOTE!

Use Medium Strength thread locking compound on M8 bolts and smaller. Apply enough thread lock to fill all gaps between the engaged bolt and nut threads.

NOTE!

All thread fasteners will have Thread locking compound applied, except the following:

1. Wheel bolts/nuts
2. Nylon insert nuts
3. Whizlock bolts and nuts
4. Fasteners less than M6 diameter
5. If specifically instructed not to apply thread locking compound

Sample manual. Download All 1276 pages at:

<https://www.arepairmanual.com/downloads/p7110b-volvo-tracked-pavers-service-manual/>

Document Title: Tightening torques	Function Group: 030	Information Type: Service Information	Date: 5/1/2026
Profile: P7110B Volvo			

[Go back to Index Page](#)

Tightening torque, specifications

Showing Selected Profile

Valid for serial numbers			
Model	Production site	Serial number start	Serial number stop
P7110B Volvo			

SAE Torque charts

Use the following recommended torque charts for bolts and nuts of SAE Grade 5 or better quality. If other torques are required, they will be indicated in the text.

Bolt (Coarse)	Torque		Bolt (Fine)	Torque	
	Nm	lbf ft		Nm	lbf ft
1/4 – 20	12	9	1/4 – 28	15	11
5/16 – 18	26	19	5/16 – 24	28	21
3/8 – 16	50	37	3/8 – 24	57	42
7/16 – 14	80	59	7/16 – 20	89	66
1/2 – 13	122	90	1/2 – 20	136	100
9/16 – 12	176	130	9/16 – 18	197	145
5/8 – 11	244	180	5/8 – 18	278	205
3/4 – 10	434	320	3/4 – 16	481	355
7/8 – 9	698	515	7/8 – 14	773	570
1 – 8	1051	775	1 – 12	1146	845
1 1/8 – 7	1492	1100	1 1/8 – 12	1668	1230
1 1/4 – 7	2088	1540	1 1/4 – 12	2319	1710
1 3/8 – 6	2739	2020	1 3/8 – 12	3119	2300
1 1/2 – 6	3648	2690	1 1/2 – 12	4095	3020

NOTE!

Torque values used in this table are based on plated, yellow zinc, dichromate bolts.

NOTE!

Use medium strength thread locking compound on bolts 5/16 inch and smaller to fill all gaps between the engaged bolt and nut threads.

NOTE!

All thread fasteners will have thread locking compound applied, except the following:

1. Wheel bolts/nuts
2. Nylon insert nuts
3. Whizlock bolts and nuts
4. Fasteners less than 1/4-inch diameter
5. If specifically instructed not to apply thread locking compound

Sample manual. Download All 1276 pages at:

<https://www.arepairmanual.com/downloads/p7110b-volvo-tracked-pavers-service-manual/>

Document Title: Thread locking compound, application/specifications	Function Group: 030	Information Type: Service Information	Date: 5/1/2026
Profile: P7110B Volvo			

Thread locking compound, application/specifications

Showing Selected Profile

Valid for serial numbers			
Model	Production site	Serial number start	Serial number stop
P7110B Volvo			

General

NOTE!

Verify that the thread locking compound is not expired!

NOTE!

Unless instructed, do not apply thread locking compound to: wheel nuts, nylon insert nuts, whiz fasteners, electrical fasteners, ground cables/bolts or fasteners less than 6 mm (1/4 in) in diameter.

Non-threaded through hole, bolt and nut

1. Clean all parts as necessary.
2. Insert bolt through hole.
3. Apply several drops of specified thread locking compound to the bolt where the nut will seat.
4. Assemble, tighten and torque as usual.

Threaded through hole

1. Clean all parts as necessary.
2. Apply several drops of specified thread locking compound to bolt.
3. Assemble, tighten and torque as usual.

Threaded blind hole

1. Clean all parts as necessary.

NOTE!

Be sure to remove any foreign material from threaded hole.

2. Apply several drops of specified thread locking compound into the threads of the blind hole.
3. Apply several drops of specified thread locking compound to bolt.
4. Assemble, tighten and torque as usual.

Document Title: Hydraulic connections, tightening torques	Function Group: 030	Information Type: Service Information	Date: 5/1/2026
Profile: P7110B Volvo			

Hydraulic connections, tightening torques

Showing Selected Profile

Valid for serial numbers			
Model	Production site	Serial number start	Serial number stop
P7110B Volvo			

JIC-coupling

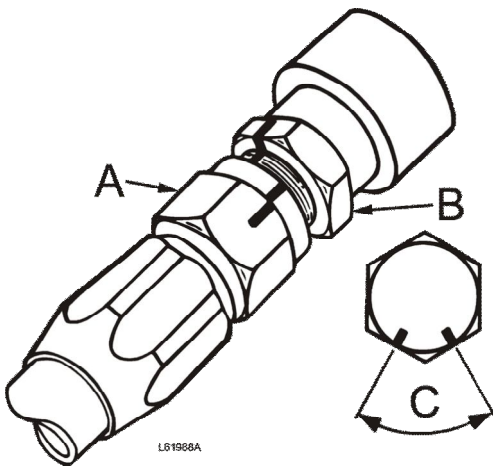

Figure 1

Hose coupling dimension (A)	Coupling size (B)	Tightening, number of hex edges (C)
9/16"		2 1/2 (150°)
5/8"	7/8"-14	2 1/2 (150°)
11/16"		2 (120°)
7/8"	1 3/16"-12	2 (120°)
1"	1 5/16"-12	1 1/2-2 (90°- 120°)
1 1/4"	1 5/8"-12	1 (60°)
1 1/2"	1 7/8"-12	3/4-1 (45°- 60°)
2"		3/4-1 (45°- 60°)
2 1/4"		1/2-1 (30°- 60°)

Tighten the coupling so that the metal surfaces in the connection are in contact with each other. Then tighten the nut as follows:

ORFS-coupling

Always install a new O-ring before an ORFS-coupling is assembled.

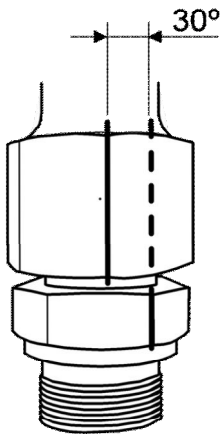

V1028462

Figure 2

Tighten the coupling so that the O-ring is compressed and the metal surfaces in the coupling are in contact with each other. Then tighten the nut another:

- 1/2 hex edge (30°) if the coupling is new.
- 1/4—1/2 hex edge (15°—30°) if the coupling is used (when only changing O-ring).

NOTE! Avoid twisting of the hose by using counterhold on the hose's hex edge.

NOTE!! In case of leakage, it does not help to tighten further, the O-ring must be changed.

Thread sealant

It is recommended to use lubricating thread sealant for any high pressure hose connections and fittings that are not JIC or ORFS fittings.

Document Title: Operation numbers for additional work	Function Group: 070	Information Type: Service Information	Date: 5/1/2026
Profile: Tracked Pavers (PAT)			

Operation numbers for additional work

Showing Selected Profile

These operations can be used to identify work that is not included in the time guide or described in the methods in the Service Manual. When these operations are used, a description of the work that has been performed must be provided.

Other work related to engine

Op. no. 070-210

This operation can be used when work has been done related to the engine and function group 2 when no applicable method description was available. When this operation is used, additional information is required:

- Description of work that has been done

Other work related to electrical system

Op. no. 070-310

This operation can be used when work has been done related to the electrical system and function group 3 when no applicable method description was available. When this operation is used, additional information is required:

- Description of work that has been done

Other work related to transmission, gearbox, travel motor, swing motor

Op. no. 070-410

This operation can be used when work has been done related to the transmission, gearbox, travel motor or swing motor and function group 4 when no applicable method description was available. When this operation is used, additional information is required:

- Description of work that has been done

Other work related to drive axle

Op. no. 070-470

This operation can be used when work has been done related to the drive axle and function group 46 when no applicable method description was available. When this operation is used, additional information is required:

- Description of required work that have been done

Other work related to brake system

Op. no. 070-510

This operation can be used when work has been done related to the brake system and function group 5 when no applicable

method description was available. When this operation is used, additional information is required:

- Description of work that has been done

Other work related to steering system

Op. no. 070-610

This operation can be used when work has been done related to the steering system and function group 6 when no applicable method description was available. When this operation is used, additional information is required:

- Description of work that has been done

Other work related to frame link, axle suspension

Op. no. 070-710

This operation can be used when work has been done related to the frame link, axle suspension and other parts related to function group 7 when no applicable method description was available. When this operation is used, additional information is required:

- Description of work that has been done

Other work related to cab, air conditioning

Op. no. 070-810

This operation can be used when work has been done related to the cab, air conditioning and other parts related to function group 8 when no applicable method description was available. When this operation is used, additional information is required:

- Description of work that has been done

Other work related to hydraulic system

Op. no. 070-910

This operation can be used when work has been done related to the hydraulic system and other parts related to function group 9 when no applicable method description was available. When this operation is used, additional information is required:

- Description of work that has been done

Document Title: E-7025	Function Group: 080	Information Type: Service Information	Date: 5/1/2026
Profile: P7110B Volvo			

E-7025

Showing Selected Profile

Valid for serial numbers			
Model	Production site	Serial number start	Serial number stop
P7110B Volvo			

Fan bearing installation tool

Dimensions on the drawing are given in mm.

E-7025

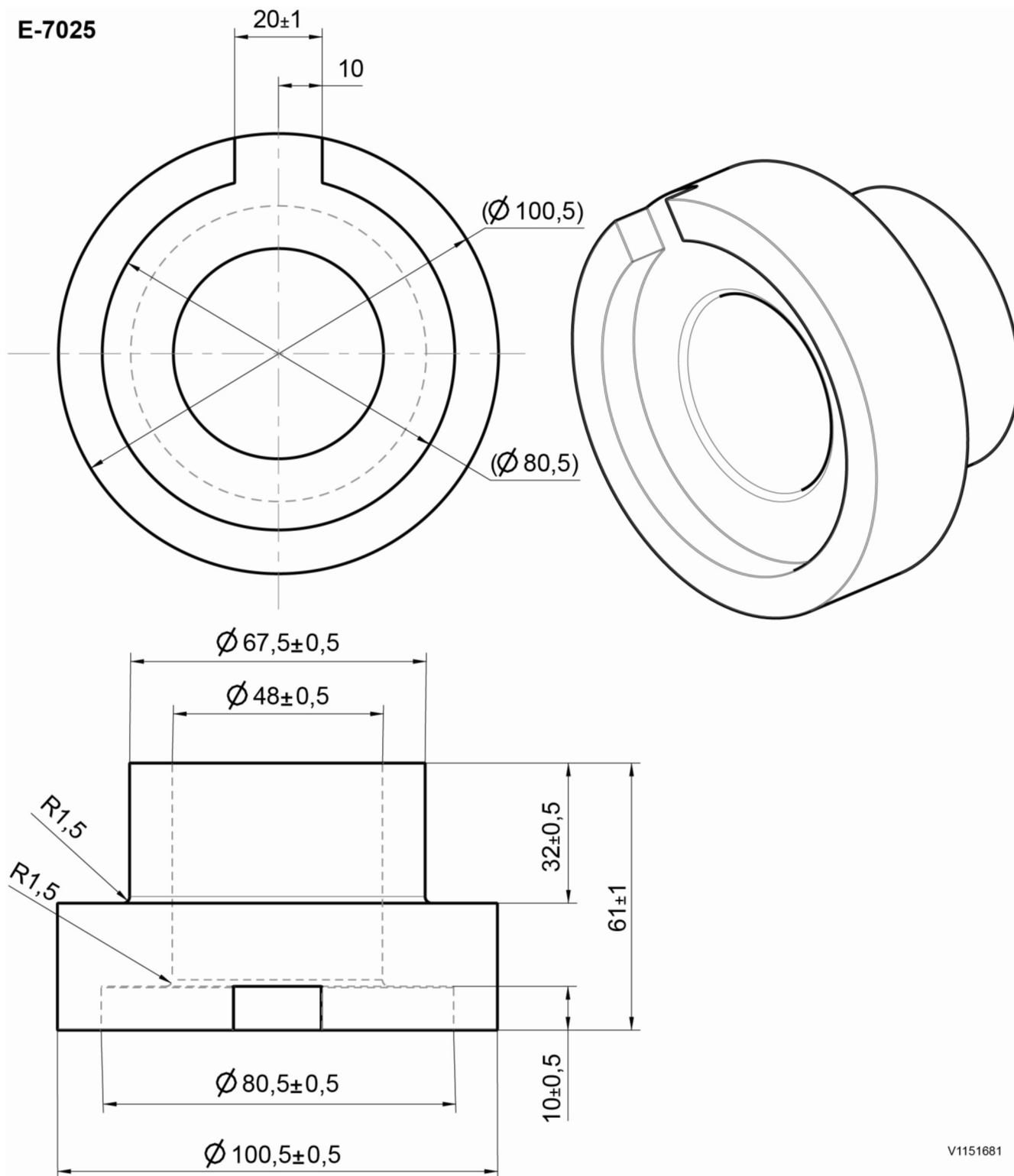

V1151681

Figure 1
Fan bearing installation tool

Material: steel

Break sharp corners.

Document Title: Recommended lubricants	Function Group: 160	Information Type: Service Information	Date: 5/1/2026
Profile: P7110B Volvo			

Recommended lubricants

Showing Selected Profile

Valid for serial numbers			
Model	Production site	Serial number start	Serial number stop
P7110B Volvo			

For questions about oils, lubricants, and extreme outdoor temperatures, contact your dealer for information.

Engine oil

Follow recommended change intervals according to the oil grade and fuel sulphur content.

Oil grade	Sulphur content of the fuel (ppm)				
	< 15	15 — 500	500 — 3000	3000 — 5000	> 5000
	Oil change interval				
Volvo Ultra Diesel Engine Oil VDS-4 Volvo Ultra Diesel Engine Oil VDS-4.5	500 hours	Do not use this grade of fuel in this machine.			
API: CJ-4 ACEA: E9	250 hours	Do not use this grade of fuel in this machine.			

Engine oil

Oil grade	Recommended viscosity at varying ambient temperatures										
	-40	-30	-20	-10	0	10	20	30	40	50	°C
	-40	-22	-4	14	32	50	68	86	104	122	°F
API C J-4 ACEA E 9 Volvo Ultra Diesel Engine Oil VDS-4 Volvo Ultra Diesel Engine Oil VDS-4.5	SAE 10W-30										
	SAE 15W-40										

Hydraulic oil

Oil grade	Recommended viscosity at varying ambient temperatures										
	-40	-30	-20	-10	0	10	20	30	40	50	°C
	-40	-22	-4	14	32	50	68	86	104	122	°F
Volvo Hydraulic Oil according to standard VCE	ISO VG 46										

1286,08 or 09											
Volvo Biodegradable Hydraulic oil according to standard VCE 1286,1	ISO VG 68										

Generator, conveyor motor and auger motor shaft grease

Lubricant	Ultra Moly Grease EP 2

Planetary and pump drive oils

Oil grade	Recommended viscosity at varying ambient temperatures										
	-40	-30	-20	-10	0	10	20	30	40	50	°C
	-40	-22	-4	14	32	50	68	86	104	122	°F
Synthetic Gear Oil, Mobil SHC 630, Chevron HiPerSYN	ISO VG 220										

All except screed and auger box grease

Oil grade	Recommended viscosity at varying ambient temperatures										
	-40	-30	-20	-10	0	10	20	30	40	50	°C
	-40	-22	-4	14	32	50	68	86	104	122	°F
Volvo Super Lithium Grease EP 2	NLGI EP 2 grease										

Screed and auger box grease

Oil grade	Recommended viscosity at varying ambient temperatures										
	-40	-30	-20	-10	0	10	20	30	40	50	°C
	-40	-22	-4	14	32	50	68	86	104	122	°F
Exxon Ronex MP	NLGI EP Grade 2 grease										

Coolant

Oil grade	Recommended mixture at varying ambient temperatures											
	-40	-30	-20	-10	0	10	20	30	40	50	°C	
	-40	-22	-4	14	32	50	68	86	104	122	°F	
Volvo coolant VCS												

50/50 coolant/water

60/40 coolant/water

Document Title: Fuel, lubricant and filling capacities	Function Group: 160	Information Type: Service Information	Date: 5/1/2026
Profile: P7110B Volvo			

Fuel, lubricant and filling capacities

Showing Selected Profile

Valid for serial numbers			
Model	Production site	Serial number start	Serial number stop
P7110B Volvo			

The following approximate fluid capacities are provided for servicing where shop facilities and resources are not available.

Fluid	Approximate capacity
Diesel fuel	356 l (94 US gal)
Hydraulic oil tank	253 l (67 US gal)
Hydraulic system capacity	341 l (90 US gal)
Engine oil	21.8 l (5.75 US gal)
Engine coolant	34 l (9 US gal)
Pump gearbox	6 l (1.6 US gal)
Traction planetary (each)	3.33 l (0.88 US gal)
AdBlue®/DEF	30.7 l (8.1 US gal)
Blaw-Kote	19 l (5 US gal)
Water tank	37.1 l (9.8 US gal)

Document Title: Alternative fuels	Function Group: 160	Information Type: Service Information	Date: 5/1/2026
Profile: Tracked Pavers (PAT)			

Alternative fuels

Showing Selected Profile

This statement is only valid for Volvo branded engines.

Hydro-treated vegetable oil (HVO) and fatty acid methyl ester (FAME) biodiesel are both made from renewable raw materials such as vegetable oils and animal fats, but they are chemically processed in different ways.

Hydro-treated vegetable oil (HVO)

HVO is created using a chemical process called hydro-treating. Hydro-treating creates an oxygen-free hydrocarbon product that is very similar to distillate diesel fuel and is well suited for use in diesel engines. HVO fuels complying with the CEN diesel fuel standard EN 590:2013 or with the European Fuel Quality Directive 98/70/EC are approved for use in all Volvo Construction Equipment diesel engines with no changes to maintenance intervals. Paraffinic diesel fuels complying with the CEN standard EN 15940 may be used in all machines operating outside the European Union and for EU-certified engines up to the emission level Stage IV. These fuels may also be used for the EU-certified D11, D13 and D16 engines meeting the emission level Stage V.

Biodiesel

Biodiesel is a product made from renewable resources such as vegetable oils or animal fat. Biodiesel that has been chemically processed into fatty acid methyl ester (FAME) can be blended with distillate diesel fuel and used in some diesel engines. Unblended biodiesel is referred to as B100 because it is 100% biodiesel.

Rapeseed methyl ester (RME) is the most common type of FAME used in Europe. Soy methyl ester (SME) and sunflower oil methyl ester (SOME) are the most common types of FAME used in the US.

Although use of FAME biodiesel is now a legal requirement in some markets, it is not as suitable for use in diesel engines as conventional diesel fuel or HVO (hydro-treated vegetable oil).

Biodiesel fuel requirements

The FAME biodiesel blends specified in the table below are approved for use if:

- The biodiesel is pre-blended by the fuel supplier
- The biodiesel used in the blend conforms to EN14214 or ASTM D6751
- The distillate fuel used in the blend meets fuel sulphur requirements
- The distillate fuel used in the blend conforms to EN590 or ASTM D975
- B1-B5 biodiesel blends conform to EN590 or ASTM D975
- B6-B7 biodiesel blends conform to EN590 or ASTM D7467
- B8-B20 biodiesel blends conform to EN16709(B20) or ASTM D7467

Engine emission designation	Engine size	Acceptable blend
EU Stage II / US Tier 2 * EU Stage IIIA / US Tier 3 * EU Stage IIIB / US Tier 4 interim EU Stage IV / US Tier 4 final EU Stage V	Below D4 / 4 litres	Up to B7
EU Stage II / US Tier 2 * EU Stage IIIA / US Tier 3 * EU Stage IIIB / US Tier 4 interim EU Stage IV / US Tier 4 final	D4–D8	Up to B7
EU Stage II / US Tier 2 * EU Stage IIIA / US Tier 3 * US Tier 4 final, special North America arrangement **	D9–D16	Up to B20
EU Stage IIIB / US Tier 4 interim EU Stage IV / US Tier 4 final	D11–D16	Up to B10

EU Stage IIIB / US Tier 4 interim, equipped with High Sulphur Fuel Conversion Kit (only available in unregulated markets)	D4–D16	Up to B20
EU Stage IV / US Tier 4 final, equipped with High Sulphur Fuel Conversion Kit (only available in unregulated markets)		
EU Stage V	D4–D16	Up to B7
<p>* As Tier 2 and Tier 3 emissions regulations ended in 2005 and 2010 respectively, engines produced since then typically meet Stage II / Stage IIIA regulations, allowing their sale in less regulated markets.</p> <p>** With additional restrictions and special operating conditions, equipment used in North America may operate on B20 diesel.</p>		

NOTE!

Failures directly caused by the use of poor quality biofuel, or any other fuel not conforming to standards, are not factory defects and the manufacturer's warranty does not apply.

Maintenance interval requirements

Additional service actions and shorter maintenance intervals are mandatory when using biodiesel blends above B10.

Every 10 hours
<ul style="list-style-type: none"> <input type="radio"/> Check the engine oil and change if it rises above the maximum fill level <input type="radio"/> Inspect the fuel system components and replace as necessary
Half of original interval
<ul style="list-style-type: none"> <input type="radio"/> Change the engine oil and filter <input type="radio"/> Replace the fuel filter(s)
Every year, regardless of operating hours
<ul style="list-style-type: none"> <input type="radio"/> Change the engine oil and filter <input type="radio"/> Clean the fuel tank

Effects of biodiesel on engine oil

Using biodiesel can lead to increased oil dilution. Use engine oil analysis tools frequently to check for fuel dilution and monitor engine oil condition. Check the engine oil level daily. Always change the engine oil if the oil level rises above the maximum fill level.

Effects of biodiesel on fuel systems

Biodiesel dissolves and loosens some fuel system deposits. During the initial conversion to biodiesel, loosened deposits will travel to the fuel filters and require more frequent fuel filter replacements. Start with new fuel filters when using biodiesel for the first time.

Biodiesel is aggressive to some materials used in fuel system components. Inspect seals, hoses, rubber and plastic components every 10 hours. Repair or replace any components that are damaged, softened or leaking. Clean biodiesel from painted surfaces immediately to prevent paint damage.

Biodiesel is more sensitive to bacteria and water contamination than distillate diesel fuel.

- Use as much fuel as possible before refilling the fuel tank in order to prevent bacteria growth if a machine is in regular use, e.g. regularly uses up a tank of fuel within a week. In climates where condensation is a risk, or when the machine is working for short durations, keep the fuel tank full.
- Do not use biodiesel in machines with low utilization or operating time.
- Do not store machines for more than 4 weeks without flushing biodiesel out of the fuel system by operating the machine through at least one full tank of distillate diesel fuel.
- Always follow the manufacturer's storage recommendations and "best-before" dates for each delivery of biodiesel.

Effects of biodiesel on exhaust aftertreatment systems

Biodiesel leaves higher levels of ash in diesel particulate filters and may require more frequent diesel particulate filter (DPF) regeneration and cleaning. Biodiesel can cause deviations in temperatures and functionality of the DPF burner and may cause fault codes or errors.

Biodiesel exhaust gas is aggressive to some materials used in selective catalytic reduction systems (SCR) and may require more frequent cleaning, repairing or replacing of SCR parts.

Effects of biodiesel on cold weather operation

Biodiesel has a high viscosity at temperatures below 0 °C (32 °F) and may cause problems starting the engine. Use a fuel heater or park machines in a heated building if possible.

Effects of biodiesel on engine performance

Biodiesel B100 has about 8% lower energy density compared to regular diesel fuel. Blends equal or lower than B20 have a small impact on engine performance.

Effects of biodiesel on emissions compliance

Engines are certified to comply with U.S. EPA, California and EU emissions standards based upon the use of test fuels with specifications established by these regulatory agencies. Alternative fuels, including biodiesel, that are not substantially similar to the required test fuels may adversely affect engine emissions compliance. As a result, Volvo does not warrant that the engine will conform to applicable Federal or California and EU emissions limits when operated on, or having previously being operated on, biodiesel or other alternative fuels that are not substantially similar to specified test fuels used for certification, nor if biodiesel / regular diesel is used in blends that exceed the recommendations.

However, the use of biodiesel up to a maximum of 20% (B20) in and of itself, will not affect the manufacturer's mechanical warranty as to engine or emissions system, provided the bio fuel used in the blend conforms to the applicable standards and the additional steps outlined herein are followed.

Document Title: AdBlue®/DEF	Function Group: 160	Information Type: Service Information	Date: 5/1/2026
Profile: P7110B Volvo			

AdBlue®/DEF

Showing Selected Profile

Valid for serial numbers			
Model	Production site	Serial number start	Serial number stop
P7110B Volvo			

NOTICE

Risk of machine damage.

In the short term, use of the wrong fluid can lead to reduced engine power. In the long term, it can lead to damage to the SCR-system and the catalyst. Reusing AdBlue®/DEF can lead to contamination. Damages caused by the use of incorrect fluids will not be covered by the warranty.

Always use fluid specified in ISO 22241-1. Do not reuse drained AdBlue®/DEF.

For reducing nitrogen oxides (NO_x) the engine is equipped with a selective catalytic reduction (SCR) system. A diesel exhaust fluid is needed for the process to work. The fluid is called AdBlue® in Europe and Asia, but in North America it is called Diesel Exhaust Fluid (DEF). When needed, the SCR system warms up the AdBlue®/DEF-tank and lines.

The fluid is filled in a separate tank, which is completely separated from the fuel tank. AdBlue®/DEF may not be mixed in the fuel tank and fuel may not be mixed in the AdBlue®/DEF-tank.

AdBlue®/DEF consists of urea crystals (32.5%) and distilled water (67.5%). It is transparent, clear, and has a slight odour of ammonia. The fluid is not considered to be hazardous, but should still be handled with care. It is very corrosive, especially with copper and aluminium. For this reason, avoid spilling the fluid on electric cables and components. Always wipe up any spilled AdBlue®/DEF.

AdBlue®/DEF is not a combustible product. When exposed to high temperatures it will convert to ammonia and carbon dioxide. The fluid should not come into contact with other chemicals or be mixed with other chemicals.

AdBlue®/DEF is sensitive to both high and low temperatures. It should not be exposed to direct sunlight for any extended period of time. If the machine is not in use, AdBlue®/DEF starts to freeze at -11 °C (12 °F). The fluid volume in the tank increases when frozen, this is why it is important to follow the recommended fill volume. AdBlue®/DEF does not break down or degrade when it freezes. The SCR-system will thaw the fluid so that it regains its concentration with maintained quality. The machine will work normally during the time that the fluid melts.

At AdBlue®/DEF temperatures above 20 °C (68 °F) the fluid starts to degrade. Then the fluid gives off ammonia, which is aggressive to materials such as rubber. At temperatures above 75–80 °C (167–176 °F), ammonia production increases. However, high temperatures are permitted for a short time.

AdBlue®/DEF should be stored in a cool, dry, and ventilated place. The fluid may not be stored in direct sunlight. The recommended storage temperature for AdBlue®/DEF is between -11 °C (12 °F) and 25 °C (77 °F). Under these conditions, storage life is approx. two years. Long-term storage of AdBlue®/DEF at a temperature above 25 °C (77 °F) can reduce the lifetime of the fluid. A short time exposure to higher temperatures has no impact on the quality.

NOTE!

If the machine is to be parked for an extended period of time (several months) in ambient temperatures above 40 °C (104 °F) the tank must be drained. This to prevent the fluid from having the wrong quality when starting the machine or that precipitates have a negative impact on the component parts.

NOTE!

If the tank has been drained completely it should be rinsed out with new AdBlue®/DEF before new fluid is filled. Never reuse old fluid. If distilled water or ordinary water is used when rinsing there is a risk that the system will generate an alarm due to wrong quality of AdBlue®/DEF.

NOTE!

Water of any kind should not be used when cleaning AdBlue®/DEF system or AdBlue®/DEF components since there is a risk that even a small amount of water remains in the system after cleaning. The only exceptions allowed are operations described in the service information made by Volvo.

AdBlue®/DEF is available in plastic container, barrel, IBC, or bulk.

For information on ordering AdBlue®/DEF (only applies to USA-market):

- Volvo Construction Equipment: 1-877-823-1111 (office hours)
- www.volvoce.com (outside of office hours)

For information on ordering AdBlue®/DEF (other markets), contact your local Volvo dealer.

Actions in case of contact with AdBlue®/DEF:

- In case of skin contact, rinse thoroughly with water. The fluid may cause irritation of the skin.
- In case of eye contact, rinse thoroughly for several minutes. If needed, contact a doctor for advice.
- In case of inhalation, breathe fresh air and contact a doctor if needed.
- If swallowed, drink water and contact a doctor.

Document Title: Scheduled maintenance	Function Group: 170	Information Type: Service Information	Date: 5/1/2026
Profile: P7110B Volvo			

Scheduled maintenance

Showing Selected Profile

Valid for serial numbers			
Model	Production site	Serial number start	Serial number stop
P7110B Volvo			

For the machine to operate safely and at the lowest possible cost, it must receive thorough and complete maintenance. Intervals for maintenance and lubrication refer to normal operating and environmental conditions. Maintenance work is described in the Operator's Manual, function group 173 of the Service Information as well as the Service Programme.

Service Programme

The check boxes in the Service Programme show what type of maintenance should be done at which interval.

Time Guide

The Time Guide shows the total time for each maintenance interval.

Document Title: Tech Tool, operations	Function Group: 170	Information Type: Service Information	Date: 5/1/2026
Profile: P7110B Volvo			

Tech Tool, operations

Showing Selected Profile

Valid for serial numbers			
Model	Production site	Serial number start	Serial number stop
P7110B Volvo			

The following Tech Tool operations are available for function group 1. Operations used when changing or working on components are mandatory.



Figure 1
Tech tool, operations
Pre-programmed

Operation	Application
17030-3, Parameter programming	Used tot read and program parameter values
17092-3 Replace hardware	Used to program control module

Document Title: Arrival Inspection, according to Inspection Programme	Function Group: 171	Information Type: Service Information	Date: 5/1/2026
Profile: Tracked Pavers (PAT)			

Arrival Inspection, according to Inspection Programme

Op nbr 171-001

Total procedure time (hr): 0.80

1. This Inspection Programme can be found as a PDF file in the document library in PROSIS.

Document Title: Delivery Inspection, according to Inspection Programme	Function Group: 171	Information Type: Service Information	Date: 5/1/2026
Profile: Tracked Pavers (PAT)			

Delivery Inspection, according to Inspection Programme

Op nbr 171-002

Total procedure time (hr): 1.75

1. This Inspection Programme can be found as a PDF file in the document library in PROSIS.

Document Title: Maintenance of Stored Machines, according to Inspection Programme	Function Group: 171	Information Type: Service Information	Date: 5/1/2026
Profile: Tracked Pavers (PAT)			

Maintenance of Stored Machines, according to Inspection Programme

Op nbr 171-003

Total procedure time (hr): 2.50

1. This Inspection Programme can be found as a PDF file in the document library in PROSIS.

Document Title: Maintenance service, first 50 hours	Function Group: 173	Information Type: Service Information	Date: 5/1/2026
Profile: P7110B Volvo			

Maintenance service, first 50 hours

Showing Selected Profile

Valid for serial numbers			
Model	Production site	Serial number start	Serial number stop
P7110B Volvo			

This interval only contains the methods that supplement the relevant standard interval. Refer to the service and maintenance introduction for examples.

Op nbr 173-035

Total procedure time (hr): 1.50

1. [Service position 1](#)
2. [Planetary drive oil, changing](#)

Document Title: Maintenance service, every 10 hours	Function Group: 173	Information Type: Service Information	Date: 5/1/2026
Profile: P7110B Volvo			

Maintenance service, every 10 hours

Showing Selected Profile

Valid for serial numbers			
Model	Production site	Serial number start	Serial number stop
P7110B Volvo			

NOTE!

The accounted times for this procedure do not include time for removal or accessibility to service points with "optional equipment" installed.

Op nbr 173-003

Total procedure time (hr): 0.30

1. [Service position 1](#)
2. [Coolers, cleaning](#)
3. [Lubrication, every 10 hours](#)
4. [Engine oil level, checking](#)
5. [Parking brake function, checking](#)

Document Title: Maintenance service, every 50 hours	Function Group: 173	Information Type: Service Information	Date: 5/1/2026
Profile: P7110B Volvo			

Maintenance service, every 50 hours

Showing Selected Profile

Valid for serial numbers			
Model	Production site	Serial number start	Serial number stop
P7110B Volvo			

NOTE!

The 50 hour maintenance service includes the 10 hour service interval. The accounted times for this procedure do not include time for removal or accessibility to service points with "optional equipment" installed.

Op nbr 173-004

Total procedure time (hr): 1.25

1. [Service position 1](#)
2. [Parking brake function, checking](#)
3. [Coolers, cleaning](#)
4. [Lubrication, every 10 hours](#)
5. [Lubrication, every 50 hours](#)
6. [Drive wheel mounting bolt torque, checking](#)
7. [Hydraulic oil level, checking](#)
8. [Water separator, checking](#)
9. [Engine air cleaner system integrity, checking](#)
10. [Coolant level, checking](#)
11. [Engine oil level, checking](#)
12. [Battery system integrity, checking](#)

Document Title: Maintenance service, every 500 hours	Function Group: 173	Information Type: Service Information	Date: 5/1/2026
Profile: P7110B Volvo			

Maintenance service, every 500 hours

Showing Selected Profile

Valid for serial numbers			
Model	Production site	Serial number start	Serial number stop
P7110B Volvo			

NOTE!

The 500 hour maintenance service includes the 50 hour and the daily service intervals. The accounted times for this procedure do not include time for removal or accessibility to service points with "optional equipment" installed.

Op nbr 173-010

Total procedure time (hr): 4.50

1. [Service position 1](#)
2. [Coolers, cleaning](#)
3. [Parking brake function, checking](#)
4. [Exhaust aftertreatment system regeneration status, checking](#)

NOTE!

The "Exhaust aftertreatment system, regenerating" must be completed before changing the engine oil and filter.

5. [Lubrication, every 10 hours](#)
6. [Lubrication, every 50 hours](#)
7. [Engine oil and filter, changing](#)
8. [Drive wheel mounting bolt torque, checking](#)
9. [Water separator filter, replacing](#)
10. [Hydraulic hoses, checking](#)
11. [Hydraulic oil filters, replacing](#)
12. [Hydraulic oil return filter, replacing](#)
13. [Engine air cleaner system integrity, checking](#)
14. [Cooling system integrity, checking](#)
15. [Coolant level, checking](#)
16. [Fuel filter, replacing](#)

17. [Battery system integrity checking](#)

Document Title: Maintenance service, every 1000 hours	Function Group: 173	Information Type: Service Information	Date: 5/1/2026
Profile: P7110B Volvo			

Maintenance service, every 1000 hours

Showing Selected Profile

Valid for serial numbers			
Model	Production site	Serial number start	Serial number stop
P7110B Volvo			

NOTE!

The 1000 hour maintenance service includes the 500 hour, 50 hour and the daily service intervals. The accounted times for this procedure do not include time for removal or accessibility to service points with "optional equipment" installed.

Op nbr 173-012

Total procedure time (hr): 36.00

1. [Software update, checking](#)
2. [Parking brake function, checking](#)
3. [Exhaust aftertreatment system regeneration status, checking](#)

NOTE!

The "Diesel particulate filter, regenerating" must be completed every 500 hours before changing the engine oil and filter.

4. [Service position 1](#)
5. [Coolers, cleaning](#)
6. [Track wheel bearing, repacking](#)
7. [Lubrication, every 10 hours](#)
8. [Lubrication, every 50 hours](#)
9. [Engine oil and filter, changing](#)
10. [Hydraulic oil, changing](#)
11. [Hydraulic oil filters, replacing](#)
12. [Hydraulic oil return filter, replacing](#)
13. [Drive wheel mounting bolt torque, checking](#)
14. [Fuel tank breather, checking](#)
15. [Water separator filter, replacing](#)
16. [Hydraulic hoses, checking](#)

Product: P7110B Volvo Tracked Pavers Service Manual

Full Download: <https://www.arepairmanual.com/downloads/p7110b-volvo-tracked>

17. [Pump gearbox oil, changing](#)

18. [Planetary drive oil, changing](#)

19. [Emulsion pump strainer, cleaning](#)

20. [Lubrication, every 1000 hours](#)

21. [Material handling components, inspecting](#)

22. [Hopper hinges, inspecting](#)

23. [Auger flights, checking](#)

24. [Auger drive chain tension, checking](#)

25. [Cooling system integrity, checking](#)

26. [Coolant level, checking](#)

27. [Engine belt condition, checking](#)

28. [Engine air cleaner system integrity, checking](#)

29. [Engine air cleaner primary filter, replacing](#)

30. [Fuel filter, replacing](#)

31. [Battery system integrity, checking](#)

Sample manual. Download All 1276 pages at:

<https://www.arepairmanual.com/downloads/p7110b-volvo-tracked-pavers-service-manual/>