

Document Title: Tightening torques	Function Group: 030	Information Type: Service Information	Date: 5/1/2026
Profile: P7110 Volvo			

Tightening torque, specifications

Showing Selected Profile

Valid for serial numbers			
Model	Production site	Serial number start	Serial number stop
P7110 Volvo			

ISO Metric Torque chart

Use the following recommended torque chart for bolts and nuts of ISO Metric strength Class 8.8 or better. If other torques are required, they will be indicated in the text

Bolt Size	Torque	
	Nm	lbs-ft
M6 x 1,0	12	9
M8 x 1,25	28	21
M10 x 1,5	61	45
M12 x 1,75	105	79
M14 x 2,0	170	125
M16 x 2,0	265	195
M20 x 2,5	515	380
M24 x 3,0	895	660
M30 x 3,5	1780	1310
M36 x 4,0	3100	2290
M42 x 3,5	4960	3660

NOTE!

Use High Strength thread locking compound on all bolts larger than M8.

NOTE!

Use Medium Strength thread locking compound on M8 bolts and smaller. Apply enough thread lock to fill all gaps between the engaged bolt and nut threads.

NOTE!

All thread fasteners will have Thread locking compound applied, except the following:

1. Wheel bolts/nuts
2. Nylon insert nuts
3. Whizlock bolts and nuts
4. Fasteners less than M6 diameter
5. If specifically instructed not to apply thread locking compound



Document Title: Conversion tables	Function Group: 030	Information Type: Service Information	Date: 5/1/2026
Profile: P7110 Volvo			

Conversion tables

Showing Selected Profile

Valid for serial numbers			
Model	Production site	Serial number start	Serial number stop
P7110 Volvo			

Length

Unit	cm	m	km	in	ft	yd	mile
cm	1	0.01	0.00001	0.3937	0.03281	0.01094	0.000006
m	100	1	0.001	39.37	3.2808	1.0936	0.00062
km	100000	1000	1	39370.7	3280.8	1093.6	0.62137
in	2.54	0.0254	0.000025	1	0.08333	0.02777	0.000015
ft	30.48	0.3048	0.000304	12	1	0.3333	0.000189
yd	91.44	0.9144	0.000914	36	3	1	0.000568
mile	160930	1609.3	1.6093	63360	5280	1760	1

1 mm = 0.1 cm - 1 mm = 0.001 m

Area

Unit	cm ²	m ²	km ²	a	ft ²	yd ²	in ²
cm ²	1	0.0001	-	0.000001	0.001076	0.000012	0.155000
m ²	10000	1	0.000001	0.01	10.764	1.1958	1550.000
km ²	-	1000000	1	10000	1076400	1195800	-
a	0.01	100	0.0001	1	1076.4	119.58	-
ft ²	-	0.092903	-	0.000929	1	0.1111	144.000
yd ²	-	0.83613	-	0.008361	9	1	1296.00
in ²	6.4516	0.000645	-	-	0.006943	0.000771	1

1 ha = 100 a - 1 mile² = 259 ha = 2.59 km²

Volume

Unit	cm ³ = cc	m ³	l	in ³	ft ³	yd ³
cm ³ = ml	1	0.000001	0.001	0.061024	0.000035	0.000001
m ³	1000000	1	1000	61024	35.315	1.30796
dm ³ (l)	1000	0.001	1	61.024	0.035315	0.001308
in ³	16.387	0.000016	0.01638	1	0.000578	0.000021
ft ³	28316.8	0.028317	28.317	1728	1	0.03704
yd ³	764529.8	0.76453	764.53	46656	27	1

1 gal (US) = 3785.41 cm³ = 231 in³ = 0.83267 gal (UK)

Sample manual. Download All 1069 pages at:

Weight
<https://www.arepairmanual.com/downloads/p7110-volvo-tracked-pavers-service-manual/>

Unit	g	kg	t	oz	lb
g	1	0.001	0.000001	0.03527	0.0022
kg	1000	1	0.001	35.273	2.20459
t	1000000	1000	1	35273	2204.59
oz	28.3495	0.02835	0.000028	1	0.0625
lb	453.592	0.45359	0.000454	16	1

1 ton (metric) = 1.1023 ton (US) = 0.9842 ton (UK)

Pressure

Unit	kp/cm ²	bar	Pa=N/m ²	kPa	lbf/in ²	lbf/ft ²
kp/cm ²	1	0.98067	98066.5	98.0665	14.2233	2048.16
bar	1.01972	1	100000	100	14.5037	2088.6
Pa=N/m ²	0.00001	0.001	1	0.001	0.00015	0.02086
kPa	0.01020	0.01	1000	1	0.14504	20.886
lbf/in ²	0.07032	0.0689	6894.76	6.89476	1	144
lbf/ft ²	0.00047	0.00047	47.88028	0.04788	0.00694	1

kg/cm² = 735.56 Dry (mmHg) = 0.96784 atm

Unit explanations

Unit	abbreviation
Newton meter	Nm
Kilopoundmeter	kpm
Kilopascal	kPa
Megapascal	MPa
Kilowatt	kW
kilojoule	kJ
British thermal unit	Btu
Calorie	ca

Approx. conversion

SI unit	Conversion factor	Non SI	Conversion factor	SI
Torque				
Nm	x10.2	=kg/cm	x0.8664	=lb in
Nm	x0.74	=lbf-ft	x1.36	=Nm
Nm	x0.102	=kg/m	x7.22	=lbft
Pressure (Pa = N/m²)				
kPa	x4.0	=in.H ₂ O	x0.249	=kPa
kPa	x0.30	=in.Hg	x3.38	=kPa
kPa	x0.145	=psi	x6.89	=kPa
bar	x14.5	=psi	x0.069	=bar
kp/cm ²	x14.22	=psi	x0.070	=kp/cm ²
N/mm ²	x145.04	=psi	x0.069	=bar
MPa	x145	=psi	x0.00689	=MPa
Power (W = J/s)				
kW	x1.36	=hp(cv)	x0.736	=kW

kW	x1.34	= bhp	x0.746	= kW
kW	x0.948	= Btu/s	x1.055	= kW
W	x0.74	= ft-lb/s	x1.36	= W
Energy (J = Nm)				
kJ	x0.948	= Btu	x1.055	= kJ
J	x0.239	= calorie	x4.19	= J
Speed and acceleration				
m/s ²	x3.28	= ft/s ²	x0.305	= m/s ²
m/s	x3.28	= ft/s	x0.305	= m/s
km/h	x0.62	= mph	x1.61	= km/h
Horsepower/torque				
Bhp x5252 rpm = TQ (lb-ft)			TQ x rpm 5252 = bhp	
Temperature				
$^{\circ}\text{C} = (^{\circ}\text{F} - 32) / 1.8$			$^{\circ}\text{F} = (^{\circ}\text{C} \times 1.8) + 32$	
Flow factor				
l/min (dm ³ /min)	x0.264	= US gal/min	x3.785	= liter/min

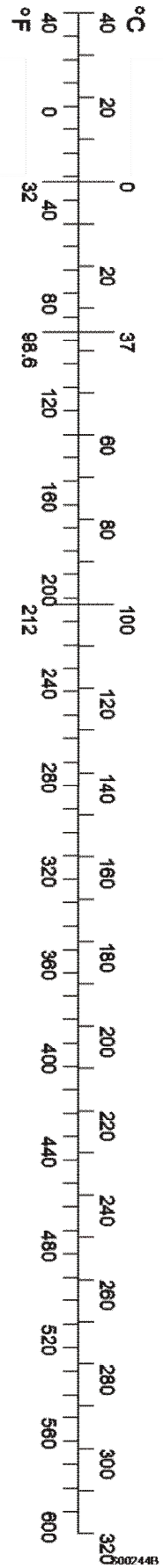

Figure 1

Document Title: Thread locking compound, application/specifications	Function Group: 030	Information Type: Service Information	Date: 5/1/2026
Profile: P7110 Volvo			

Thread locking compound, application/specifications

Showing Selected Profile

Valid for serial numbers			
Model	Production site	Serial number start	Serial number stop
P7110 Volvo			

General

NOTE!

Verify that the thread locking compound is not expired!

NOTE!

Unless instructed, do not apply thread locking compound to: wheel nuts, nylon insert nuts, whiz fasteners, electrical fasteners, ground cables/bolts or fasteners less than 6 mm (1/4 in) in diameter.

Non-threaded through hole, bolt and nut

1. Clean all parts as necessary.
2. Insert bolt through hole.
3. Apply several drops of specified thread locking compound to the bolt where the nut will seat.
4. Assemble, tighten and torque as usual.

Threaded through hole

1. Clean all parts as necessary.
2. Apply several drops of specified thread locking compound to bolt.
3. Assemble, tighten and torque as usual.

Threaded blind hole

1. Clean all parts as necessary.

NOTE!

Be sure to remove any foreign material from threaded hole.

2. Apply several drops of specified thread locking compound into the threads of the blind hole.
3. Apply several drops of specified thread locking compound to bolt.
4. Assemble, tighten and torque as usual.

Document Title: Critical mounting torques	Function Group: 030	Information Type: Service Information	Date: 5/1/2026
Profile: P7110 Volvo			

Critical mounting torques

Showing Selected Profile

Valid for serial numbers			
Model	Production site	Serial number start	Serial number stop
P7110 Volvo			

Use the following recommended torque chart for bolts and nuts of SAE Grade 5 or better quality. If other torques are required, they will be indicated in the text.

Critical mounting torques

Function of fastener	Size	Torque	
		Nm	lb ft
Auger shaft bearing cover, socket head screws		100	75
Auger shaft bearing setscrew (inside cover)		35	25
Reversing auger hydraulic manifold valve, socket head screws		14	10
Auger lift cylinder guide plate to auger assembly, bolt	M12	150	110
Auger shield bolt	M12	150	110
Auger bolt	M20	163	120
Auger motor backing plate counter sunk screw		105	79
Hydraulic oil tank return filter canister cover		30±3	22±2
Reversing conveyor hydraulic manifold valve, socket head screws		14	10
Pump box to bell housing, socket head screws	M10	55	41
Radiator stiffener to radiator, bolt	M10	47	35
Pedestal mounting plate lock nut	M140	135.5	100
Engine sub frame to bell housing, bolt	M12	101	75
Rear engine mount to pump box, bolt	M12	105	79
Rear engine mount to rear engine brace, bolt	M10	86	64
Engine coupling centre hub, socket head screw		50	37
Clutch ring gear to flywheel, bolt	3/8-16	72	52
Front and rear engine isolator, bolt	3/4-10	270	195
Compensation cylinders to main frame		265	195
Fan motor assembly to finger guard	M10	54	40
Tee handle		20	15

Air cleaner to air cleaner mounting bracket, bolt	M8	20	15
Air cleaner mounting bracket to radiator support		65	48
Lower alternator bolt		60	44
Upper alternator bolt		70	52
Bogie wheel mounting nuts		290	214
Bogie wheel spindle mounting nut		88	65
Track frame mounting bolts	M24	1260	930
Fan hub assembly setscrews		10	8
Planetary/motor assembly to mainframe	M20	340	250
Power tunnel cylinder to main frame	M20	136	100
Tunnel cylinder rod to tunnel end cap (2) hex nut	M20	272	200
Tunnel end cap to main frame	M10	61.2	45
Drive wheel to planetary, bolt	M20	510	376
Screed cylinder saddle, bolt	M12	105	79
Screed assist, 2-way valve cartridge		30	23
Screed assist, pressure reducing valve		44	33
Screed lock, valve		44	33
Screed plate mounting bolts		47	35
Conveyor motor to mounting plate		375	275
Sprocket to shaft		150	110
Conveyor motor assembly		375	275
Fumes fan motor shaft nut		8	10
Fumes fan set screws		8	10
Fumes fan intake tube to the fumes fan housing		5	6
Front general purpose valve mounting bolts		72	53
Tow point to tow arm		375	275
Tow point to screed lift cylinder		290–305	214–225

Document Title: Coolant, specifications	Function Group: 030	Information Type: Service Information	Date: 5/1/2026
Profile: P7110 Volvo			

Coolant, specifications

Showing Selected Profile

Valid for serial numbers			
Model	Production site	Serial number start	Serial number stop
P7110 Volvo			

Only use Volvo Coolant VCS when filling and changing coolant. Mixing with other coolants or corrosion protection may result in engine damage.

Freeze protection down to	Content of concentrated VCS
-25 °C (-13 °F)	40 %
-30 °C (-22 °F)	46 %
-38 °C (-36 °F)	54 %
-46 °C (-51 °F)	60 %

NOTE!

The concentrated Volvo Coolant VCS must not be mixed with water that contains a high degree of lime (hard water), salt or metal. The clean water for the cooling system must also meet the following requirements:

Description	Value
Total number of solid particles	< 340 ppm
Total hardness	< 9.5 ° dH
Chloride	< 40 ppm
Sulphate	< 100 ppm
Acidity (pH value)	5.5–9
Silica	< 20 mg SiO ₂ /litre
Iron	< 0.01 mg Fe/litre
Manganese	< 0.05 mg Mn/litre
Electrical conductivity	< 500 µS/cm
Organic content, COD-Mn	< 15 mg/litre

If in doubt of the water's quality, use Volvo Coolant Ready Mixed. Do not mix with other ready-mixed coolants as this may result in engine damage.

Document Title: Fuel, specifications	Function Group: 030	Information Type: Service Information	Date: 5/1/2026
Profile: P7110 Volvo			

Fuel, specifications

Showing Selected Profile

Valid for serial numbers			
Model	Production site	Serial number start	Serial number stop
P7110 Volvo			

Description	Specification
Europe	EN590
USA and Canada	ASTM D 975 1-D and 2-D
Japan	JIS KK 2204

Document Title: Hydraulic connections, tightening torques	Function Group: 030	Information Type: Service Information	Date: 5/1/2026
Profile: P7110 Volvo			

Hydraulic connections, tightening torques

Showing Selected Profile

Valid for serial numbers			
Model	Production site	Serial number start	Serial number stop
P7110 Volvo			

JIC-coupling

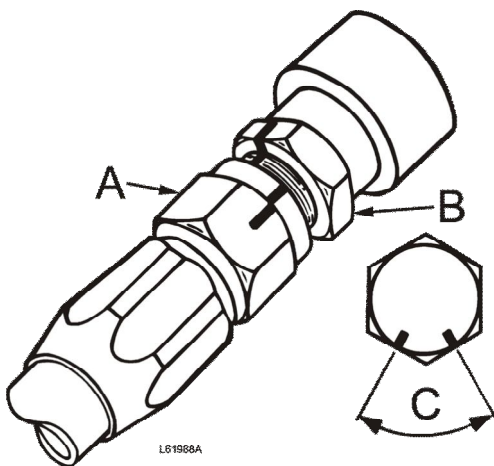

Figure 1

Hose coupling dimension (A)	Coupling size (B)	Tightening, number of hex edges (C)
9/16"		2 1/2 (150°)
5/8"	7/8"-14	2 1/2 (150°)
11/16"		2 (120°)
7/8"	1 3/16"-12	2 (120°)
1"	1 5/16"-12	1 1/2-2 (90°- 120°)
1 1/4"	1 5/8"-12	1 (60°)
1 1/2"	1 7/8"-12	3/4-1 (45°- 60°)
2"		3/4-1 (45°- 60°)
2 1/4"		1/2-1 (30°- 60°)

Tighten the coupling so that the metal surfaces in the connection are in contact with each other. Then tighten the nut as follows:

ORFS-coupling

Always install a new O-ring before an ORFS-coupling is assembled.

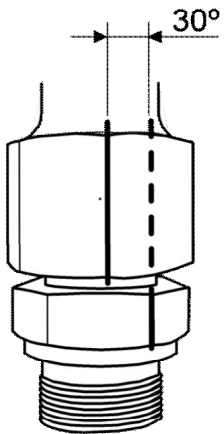

V1028462

Figure 2

Tighten the coupling so that the O-ring is compressed and the metal surfaces in the coupling are in contact with each other. Then tighten the nut another:

- 1/2 hex edge (30°) if the coupling is new.
- 1/4—1/2 hex edge (15°—30°) if the coupling is used (when only changing O-ring).

NOTE! Avoid twisting of the hose by using counterhold on the hose's hex edge.

NOTE!! In case of leakage, it does not help to tighten further, the O-ring must be changed.

Thread sealant

It is recommended to use lubricating thread sealant for any high pressure hose connections and fittings that are not JIC or ORFS fittings.

Document Title: Operation numbers for additional work	Function Group: 070	Information Type: Service Information	Date: 5/1/2026
Profile: Tracked Pavers (PAT)			

Operation numbers for additional work

Showing Selected Profile

These operations can be used to identify work that is not included in the time guide or described in the methods in the Service Manual. When these operations are used, a description of the work that has been performed must be provided.

Other work related to engine

Op. no. 070-210

This operation can be used when work has been done related to the engine and function group 2 when no applicable method description was available. When this operation is used, additional information is required:

- Description of work that has been done

Other work related to electrical system

Op. no. 070-310

This operation can be used when work has been done related to the electrical system and function group 3 when no applicable method description was available. When this operation is used, additional information is required:

- Description of work that has been done

Other work related to transmission, gearbox, travel motor, swing motor

Op. no. 070-410

This operation can be used when work has been done related to the transmission, gearbox, travel motor or swing motor and function group 4 when no applicable method description was available. When this operation is used, additional information is required:

- Description of work that has been done

Other work related to drive axle

Op. no. 070-470

This operation can be used when work has been done related to the drive axle and function group 46 when no applicable method description was available. When this operation is used, additional information is required:

- Description of required work that have been done

Other work related to brake system

Op. no. 070-510

This operation can be used when work has been done related to the brake system and function group 5 when no applicable

method description was available. When this operation is used, additional information is required:

- Description of work that has been done

Other work related to steering system

Op. no. 070-610

This operation can be used when work has been done related to the steering system and function group 6 when no applicable method description was available. When this operation is used, additional information is required:

- Description of work that has been done

Other work related to frame link, axle suspension

Op. no. 070-710

This operation can be used when work has been done related to the frame link, axle suspension and other parts related to function group 7 when no applicable method description was available. When this operation is used, additional information is required:

- Description of work that has been done

Other work related to cab, air conditioning

Op. no. 070-810

This operation can be used when work has been done related to the cab, air conditioning and other parts related to function group 8 when no applicable method description was available. When this operation is used, additional information is required:

- Description of work that has been done

Other work related to hydraulic system

Op. no. 070-910

This operation can be used when work has been done related to the hydraulic system and other parts related to function group 9 when no applicable method description was available. When this operation is used, additional information is required:

- Description of work that has been done

Document Title: E-7025	Function Group: 080	Information Type: Service Information	Date: 5/1/2026
Profile: P7110 Volvo			

E-7025

Showing Selected Profile

Valid for serial numbers			
Model	Production site	Serial number start	Serial number stop
P7110 Volvo			

Fan bearing installation tool

Dimensions on the drawing are given in mm.

E-7025

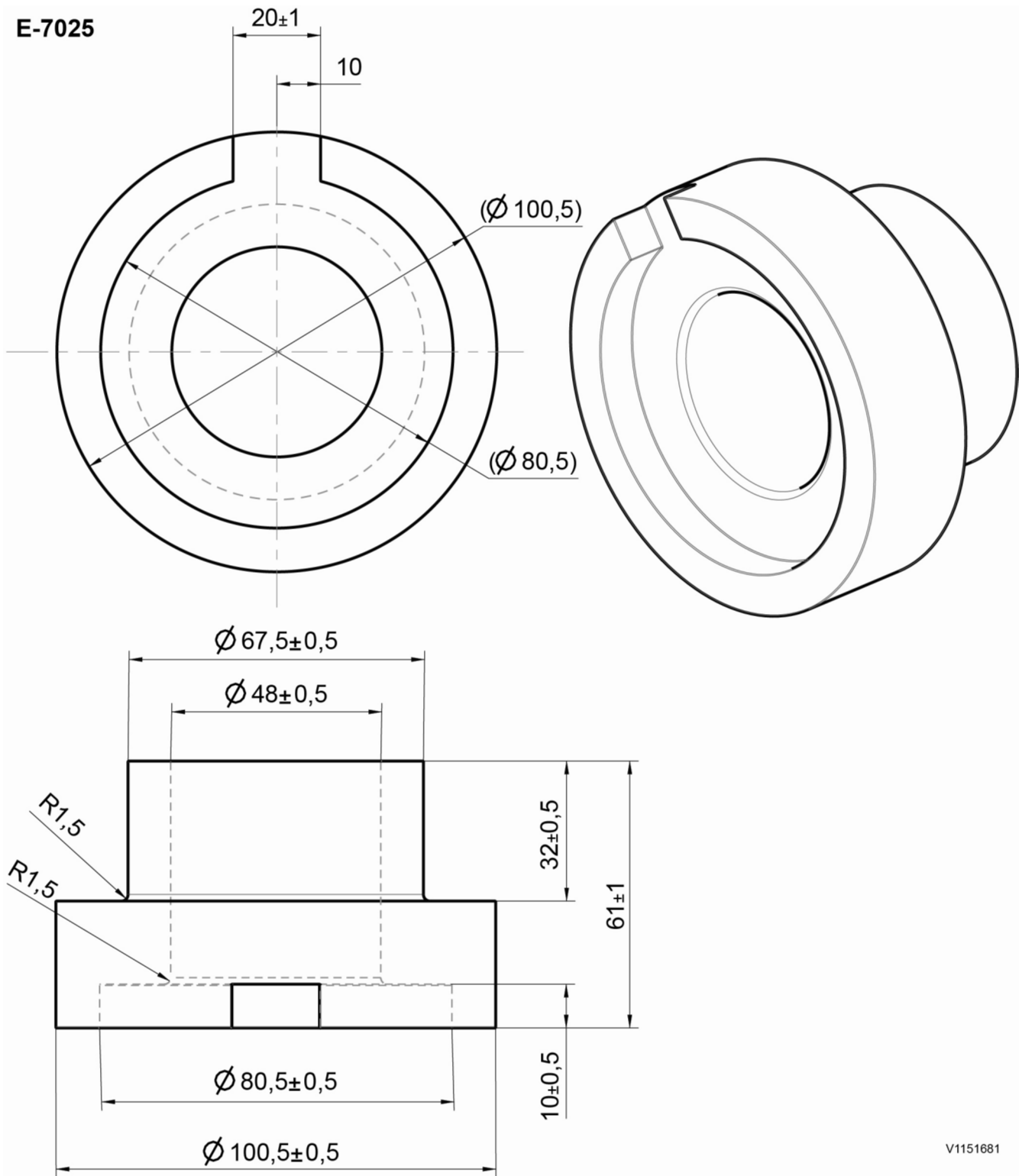

V1151681

Figure 1
Fan bearing installation tool

Material: steel

Break sharp corners.

Document Title: Recommended lubricants	Function Group: 160	Information Type: Service Information	Date: 5/1/2026
Profile: P7110 Volvo			

Recommended lubricants

Showing Selected Profile

Valid for serial numbers			
Model	Production site	Serial number start	Serial number stop
P7110 Volvo			

For questions about oils, lubricants, and extreme outdoor temperatures, contact your dealer for information.

Engine oil

Follow recommended change intervals according to the oil grade and fuel sulphur content.

Oil grade	Sulphur content of the fuel (ppm)				
	< 15	15 — 500	500 — 3000	3000 — 5000	> 5000
	Oil change interval				
Volvo Ultra Diesel Engine Oil VDS-4 Volvo Ultra Diesel Engine Oil VDS-4.5	500 hours	Do not use this grade of fuel in this machine.			
API: CJ-4 ACEA: E9	250 hours	Do not use this grade of fuel in this machine.			

Engine oil

Oil grade	Recommended viscosity at varying ambient temperatures										
	-40	-30	-20	-10	0	10	20	30	40	50	°C
	-40	-22	-4	14	32	50	68	86	104	122	°F
API C J-4 ACEA E 9 Volvo Ultra Diesel Engine Oil VDS-4 Volvo Ultra Diesel Engine Oil VDS-4.5	SAE 10W-30										
	SAE 15W-40										

Hydraulic oil

Oil grade	Recommended viscosity at varying ambient temperatures										
	-40	-30	-20	-10	0	10	20	30	40	50	°C
	-40	-22	-4	14	32	50	68	86	104	122	°F
Volvo Hydraulic Oil according to standard VCE	ISO VG 46										

Document Title: Fuel, lubricant and filling capacities	Function Group: 160	Information Type: Service Information	Date: 5/1/2026
Profile: P7110 Volvo			

Fuel, lubricant and filling capacities

Showing Selected Profile

Valid for serial numbers			
Model	Production site	Serial number start	Serial number stop
P7110 Volvo			

The following approximate fluid capacities are provided for servicing where shop facilities and resources are not available.

FLUID/OIL	APPROXIMATE CAPACITY
Diesel Fuel	356 L (94 US gal)
Hydraulic Oil	253,4 L (67 US gal)
Engine Oil	20 L (21 qt)
Engine Coolant	34,1 L (36 qt)
Pump Drive Box	6,1 L (1,6 US gal)
Traction Planetary (each)	3,4 L (0,9 US gal)
Auger Box	3,7 kg (8 lbs)

Document Title: Alternative fuels	Function Group: 160	Information Type: Service Information	Date: 5/1/2026
Profile: Tracked Pavers (PAT)			

Alternative fuels

Showing Selected Profile

This statement is only valid for Volvo branded engines.

Hydro-treated vegetable oil (HVO) and fatty acid methyl ester (FAME) biodiesel are both made from renewable raw materials such as vegetable oils and animal fats, but they are chemically processed in different ways.

Hydro-treated vegetable oil (HVO)

HVO is created using a chemical process called hydro-treating. Hydro-treating creates an oxygen-free hydrocarbon product that is very similar to distillate diesel fuel and is well suited for use in diesel engines. HVO fuels complying with the CEN diesel fuel standard EN 590:2013 or with the European Fuel Quality Directive 98/70/EC are approved for use in all Volvo Construction Equipment diesel engines with no changes to maintenance intervals. Paraffinic diesel fuels complying with the CEN standard EN 15940 may be used in all machines operating outside the European Union and for EU-certified engines up to the emission level Stage IV. These fuels may also be used for the EU-certified D11, D13 and D16 engines meeting the emission level Stage V.

Biodiesel

Biodiesel is a product made from renewable resources such as vegetable oils or animal fat. Biodiesel that has been chemically processed into fatty acid methyl ester (FAME) can be blended with distillate diesel fuel and used in some diesel engines. Unblended biodiesel is referred to as B100 because it is 100% biodiesel.

Rapeseed methyl ester (RME) is the most common type of FAME used in Europe. Soy methyl ester (SME) and sunflower oil methyl ester (SOME) are the most common types of FAME used in the US.

Although use of FAME biodiesel is now a legal requirement in some markets, it is not as suitable for use in diesel engines as conventional diesel fuel or HVO (hydro-treated vegetable oil).

Biodiesel fuel requirements

The FAME biodiesel blends specified in the table below are approved for use if:

- The biodiesel is pre-blended by the fuel supplier
- The biodiesel used in the blend conforms to EN14214 or ASTM D6751
- The distillate fuel used in the blend meets fuel sulphur requirements
- The distillate fuel used in the blend conforms to EN590 or ASTM D975
- B1-B5 biodiesel blends conform to EN590 or ASTM D975
- B6-B7 biodiesel blends conform to EN590 or ASTM D7467
- B8-B20 biodiesel blends conform to EN16709(B20) or ASTM D7467

Engine emission designation	Engine size	Acceptable blend
EU Stage II / US Tier 2 * EU Stage IIIA / US Tier 3 * EU Stage IIIB / US Tier 4 interim EU Stage IV / US Tier 4 final EU Stage V	Below D4 / 4 litres	Up to B7
EU Stage II / US Tier 2 * EU Stage IIIA / US Tier 3 * EU Stage IIIB / US Tier 4 interim EU Stage IV / US Tier 4 final	D4–D8	Up to B7
EU Stage II / US Tier 2 * EU Stage IIIA / US Tier 3 * US Tier 4 final, special North America arrangement **	D9–D16	Up to B20
EU Stage IIIB / US Tier 4 interim EU Stage IV / US Tier 4 final	D11–D16	Up to B10

EU Stage IIIB / US Tier 4 interim, equipped with High Sulphur Fuel Conversion Kit (only available in unregulated markets)	D4–D16	Up to B20
EU Stage IV / US Tier 4 final, equipped with High Sulphur Fuel Conversion Kit (only available in unregulated markets)		
EU Stage V	D4–D16	Up to B7
<p>* As Tier 2 and Tier 3 emissions regulations ended in 2005 and 2010 respectively, engines produced since then typically meet Stage II / Stage IIIA regulations, allowing their sale in less regulated markets.</p> <p>** With additional restrictions and special operating conditions, equipment used in North America may operate on B20 diesel.</p>		

NOTE!

Failures directly caused by the use of poor quality biofuel, or any other fuel not conforming to standards, are not factory defects and the manufacturer's warranty does not apply.

Maintenance interval requirements

Additional service actions and shorter maintenance intervals are mandatory when using biodiesel blends above B10.

Every 10 hours
<ul style="list-style-type: none"> <input type="radio"/> Check the engine oil and change if it rises above the maximum fill level <input type="radio"/> Inspect the fuel system components and replace as necessary
Half of original interval
<ul style="list-style-type: none"> <input type="radio"/> Change the engine oil and filter <input type="radio"/> Replace the fuel filter(s)
Every year, regardless of operating hours
<ul style="list-style-type: none"> <input type="radio"/> Change the engine oil and filter <input type="radio"/> Clean the fuel tank

Effects of biodiesel on engine oil

Using biodiesel can lead to increased oil dilution. Use engine oil analysis tools frequently to check for fuel dilution and monitor engine oil condition. Check the engine oil level daily. Always change the engine oil if the oil level rises above the maximum fill level.

Effects of biodiesel on fuel systems

Biodiesel dissolves and loosens some fuel system deposits. During the initial conversion to biodiesel, loosened deposits will travel to the fuel filters and require more frequent fuel filter replacements. Start with new fuel filters when using biodiesel for the first time.

Biodiesel is aggressive to some materials used in fuel system components. Inspect seals, hoses, rubber and plastic components every 10 hours. Repair or replace any components that are damaged, softened or leaking. Clean biodiesel from painted surfaces immediately to prevent paint damage.

Biodiesel is more sensitive to bacteria and water contamination than distillate diesel fuel.

- Use as much fuel as possible before refilling the fuel tank in order to prevent bacteria growth if a machine is in regular use, e.g. regularly uses up a tank of fuel within a week. In climates where condensation is a risk, or when the machine is working for short durations, keep the fuel tank full.
- Do not use biodiesel in machines with low utilization or operating time.
- Do not store machines for more than 4 weeks without flushing biodiesel out of the fuel system by operating the machine through at least one full tank of distillate diesel fuel.
- Always follow the manufacturer's storage recommendations and "best-before" dates for each delivery of biodiesel.

Effects of biodiesel on exhaust aftertreatment systems

Biodiesel leaves higher levels of ash in diesel particulate filters and may require more frequent diesel particulate filter (DPF) regeneration and cleaning. Biodiesel can cause deviations in temperatures and functionality of the DPF burner and may cause fault codes or errors.

Biodiesel exhaust gas is aggressive to some materials used in selective catalytic reduction systems (SCR) and may require more frequent cleaning, repairing or replacing of SCR parts.

Effects of biodiesel on cold weather operation

Biodiesel has a high viscosity at temperatures below 0 °C (32 °F) and may cause problems starting the engine. Use a fuel heater or park machines in a heated building if possible.

Effects of biodiesel on engine performance

Biodiesel B100 has about 8% lower energy density compared to regular diesel fuel. Blends equal or lower than B20 have a small impact on engine performance.

Effects of biodiesel on emissions compliance

Engines are certified to comply with U.S. EPA, California and EU emissions standards based upon the use of test fuels with specifications established by these regulatory agencies. Alternative fuels, including biodiesel, that are not substantially similar to the required test fuels may adversely affect engine emissions compliance. As a result, Volvo does not warrant that the engine will conform to applicable Federal or California and EU emissions limits when operated on, or having previously being operated on, biodiesel or other alternative fuels that are not substantially similar to specified test fuels used for certification, nor if biodiesel / regular diesel is used in blends that exceed the recommendations.

However, the use of biodiesel up to a maximum of 20% (B20) in and of itself, will not affect the manufacturer's mechanical warranty as to engine or emissions system, provided the bio fuel used in the blend conforms to the applicable standards and the additional steps outlined herein are followed.

Document Title: Scheduled maintenance	Function Group: 170	Information Type: Service Information	Date: 5/1/2026
Profile: P7110 Volvo			

Scheduled maintenance

Showing Selected Profile

Valid for serial numbers			
Model	Production site	Serial number start	Serial number stop
P7110 Volvo			

For the machine to operate safely and at the lowest possible cost, it must receive thorough and complete maintenance. Intervals for maintenance and lubrication refer to normal operating and environmental conditions. Maintenance work is described in the Operator's Manual, function group 173 of the Service Information as well as the Service Programme.

Service Programme

The check boxes in the Service Programme show what type of maintenance should be done at which interval.

Time Guide

The Time Guide shows the total time for each maintenance interval.

Document Title: Arrival Inspection, according to Inspection Programme	Function Group: 171	Information Type: Service Information	Date: 5/1/2026
Profile: Tracked Pavers (PAT)			

Arrival Inspection, according to Inspection Programme

Op nbr 171-001

Total procedure time (hr): 0.80

1. This Inspection Programme can be found as a PDF file in the document library in PROSIS.

Document Title: Delivery Inspection, according to Inspection Programme	Function Group: 171	Information Type: Service Information	Date: 5/1/2026
Profile: Tracked Pavers (PAT)			

Delivery Inspection, according to Inspection Programme

Op nbr 171-002

Total procedure time (hr): 1.75

1. This Inspection Programme can be found as a PDF file in the document library in PROSIS.

Document Title: Maintenance of Stored Machines, according to Inspection Programme	Function Group: 171	Information Type: Service Information	Date: 5/1/2026
Profile: Tracked Pavers (PAT)			

Maintenance of Stored Machines, according to Inspection Programme

Op nbr 171-003

Total procedure time (hr): 2.50

1. This Inspection Programme can be found as a PDF file in the document library in PROSIS.

Document Title: Maintenance service, every 10 hours	Function Group: 173	Information Type: Service Information	Date: 5/1/2026
Profile: P7110 Volvo			

Maintenance service, every 10 hours

Showing Selected Profile

Valid for serial numbers			
Model	Production site	Serial number start	Serial number stop
P7110 Volvo			

NOTE!

The accounted times for this procedure do not include time for removal or accessibility to service points with "optional equipment" installed.

Op nbr 173-003

Total procedure time (hr): 0.30

1. [Service position 1](#)
2. [Coolers, cleaning](#)
3. [Lubrication, every 10 hours](#)
4. [Engine oil level, checking](#)
5. [Parking brake function, checking](#)

Document Title: Maintenance service, every 50 hours	Function Group: 173	Information Type: Service Information	Date: 5/1/2026
Profile: P7110 Volvo			

Maintenance service, every 50 hours

Showing Selected Profile

Valid for serial numbers			
Model	Production site	Serial number start	Serial number stop
P7110 Volvo			

NOTE!

The 50 hour maintenance service includes the 10 hour service interval. The accounted times for this procedure do not include time for removal or accessibility to service points with "optional equipment" installed.

Op nbr 173-004

Total procedure time (hr): 1.25

1. [Service position 1](#)
2. [Parking brake function, checking](#)
3. [Coolers, cleaning](#)
4. [Lubrication, every 10 hours](#)
5. [Lubrication, every 50 hours](#)
6. [Drive wheel mounting bolt torque, checking](#)
7. [Hydraulic oil level, checking](#)
8. [Water separator, checking](#)
9. [Engine air cleaner system integrity, checking](#)
10. [Coolant level, checking](#)
11. [Engine oil level, checking](#)
12. [Battery system integrity, checking](#)

Document Title: Maintenance service, every 500 hours	Function Group: 173	Information Type: Service Information	Date: 5/1/2026
Profile: P7110 Volvo			

Maintenance service, every 500 hours

Showing Selected Profile

Valid for serial numbers			
Model	Production site	Serial number start	Serial number stop
P7110 Volvo			

NOTE!

The 500 hour maintenance service includes the 50 hour and the daily service intervals. The accounted times for this procedure do not include time for removal or accessibility to service points with "optional equipment" installed.

NOTE!

The "Exhaust aftertreatment system, regenerating" must be completed before changing the engine oil and filter.

Op nbr 173-010

Total procedure time (hr): 3.00

1. [Service position 1](#)
2. [Cooling system integrity, checking](#)
3. [Coolant mixture, checking](#)
4. [Battery system integrity, checking](#)
5. [Engine air cleaner system integrity, checking](#)
6. [Engine oil and filter, changing](#)
7. [Fuel filter, replacing](#)
8. [Hydraulic hoses, checking](#)
9. [Hydraulic oil return filter, replacing](#)
10. [Hydraulic oil filters, replacing](#)
11. [Water separator filter, replacing](#)
12. [Lubrication, every 50 hours](#)
13. [Parking brake function, checking](#)



Document Title: Maintenance service, every 1000 hours	Function Group: 173	Information Type: Service Information	Date: 5/1/2026
Profile: P7110 Volvo			

Maintenance service, every 1000 hours

Showing Selected Profile

Valid for serial numbers			
Model	Production site	Serial number start	Serial number stop
P7110 Volvo			

NOTE!

The 1000 hour maintenance service includes the 500 hour, 50 hour and the daily service intervals. The accounted times for this procedure do not include time for removal or accessibility to service points with "optional equipment" installed.

Op nbr 173-012

Total procedure time (hr): 36.00

1. [Service position 1](#)
2. [Coolers, cleaning](#)
3. [Parking brake function, checking](#)
4. [Exhaust aftertreatment system regeneration status, checking](#)

NOTE!

The "Diesel particulate filter, regenerating" must be completed every 500 hours before changing the engine oil and filter.

5. [Track wheel bearing, repacking](#)
6. [Lubrication, every 10 hours](#)
7. [Lubrication, every 50 hours](#)
8. [Engine oil and filter, changing](#)
9. [Hydraulic oil, changing](#)
10. [Hydraulic oil filters, replacing](#)
11. [Hydraulic oil return filter, replacing](#)
12. [Drive wheel mounting bolt torque, checking](#)
13. [Fuel tank breather, checking](#)
14. [Water separator filter, replacing](#)
15. [Hydraulic hoses, checking](#)