

Document Title: <b>Description</b>	Function Group: <b>000</b>	Information Type: <b>Service Information</b>	Date: <b>4/29/2026</b>
Profile: <b>ABG8820 Volvo PID:80673585</b>			

## Description

Showing Selected Profile

Valid for serial numbers			
Model	Production site	Serial number start	Serial number stop
ABG8820 Volvo PID:80673585			

The machine is designed for application of all types of graded asphalt aggregates, hydraulically bonded graded aggregates, graded ballast, sand or gravel.

The engine is a six-cylinder, four-stroke, in-line diesel engine with direct injection and water cooling.

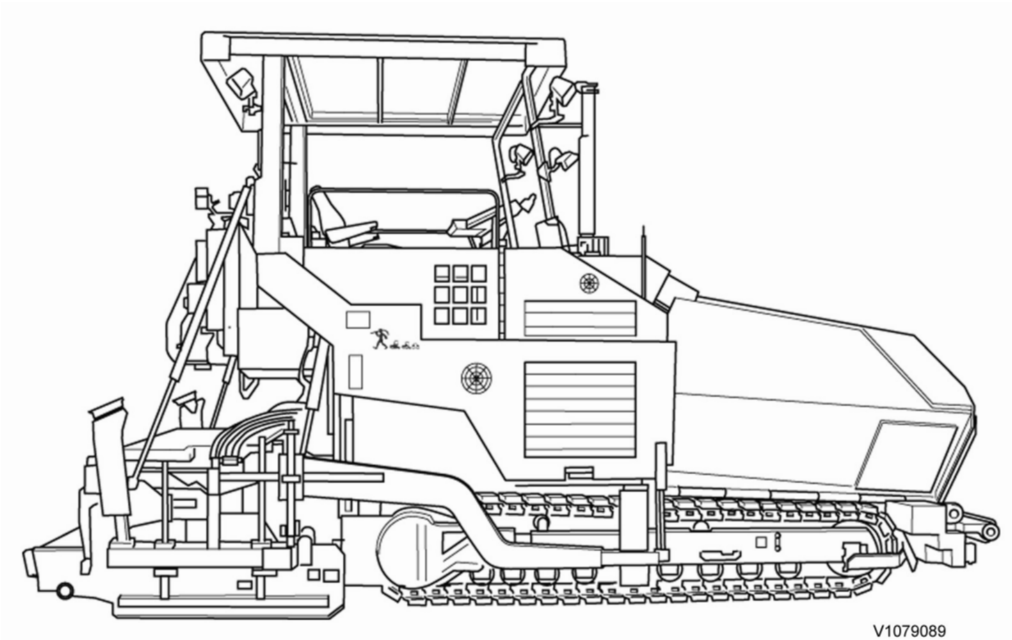

V1079089

**Figure 1**  
General View

Document Title: <b>Standard tightening torques</b>	Function Group: <b>030</b>	Information Type: <b>Service Information</b>	Date: <b>4/29/2026</b>
Profile: <b>ABG8820 Volvo PID:80673585</b>			

## Standard tightening torques

Showing Selected Profile

Valid for serial numbers			
Model	Production site	Serial number start	Serial number stop
ABG8820 Volvo PID:80673585			

Tightening torques in the following tables refer to bolted joints with tensile strength according to the below. The tables should be regarded as general guidelines for tightening bolted joints where nothing else is specified.

**NOTE!**

Increase the values by 10% for flange bolt type U6FS. Bolts and nuts should be clean and lubricated with oil.

Surface coating		Coefficient of friction	
Non-electrolytic zinc plate coatings	ISO10683-FLZN/ZN/TL/480	0.08	
	ISO10683-FLZN/ZN/TL/720		
	(ISO10683) Geomet 500A	0.12	
Yellowish iridescent	ISO4042-A2C		
Electrolytic coating	ASTMF 1941 Fe/Zn5ANS	0.24	

Dimension s	Strength classes	Coefficient of friction					
		0.08		0.12		0.24	
		Tightening torque (Nm)	Tightening torques: (lbf ft)	Tightening torque (Nm)	Tightening torques: (lbf ft)	Tightening torque (Nm)	Tightening torques: (lbf ft)
M4	8.8	2.3	1.7	3	2.21	3.8	2.8
	10.9	3.3	2.43	4.6	3.39	5.5	4.06
	12.9	3.9	2.87	5.1	3.76	6.5	4.79
M5	8.8	4.4	3.24	5.9	4.35	7.5	5.53
	10.9	6.5	4.79	8.6	6.34	11	8.11
	12.9	7.6	5.61	10	7.37	12.9	9.51
M6	8.8	7.7	5.67	10.1	7.44	13	9.59
	10.9	11.3	8.33	14.9	10.98	19.1	14.09
	12.9	13.2	9.73	17.4	12.83	22.3	16.45
M7	8.8	12.6	9.29	16.8	12.39	21.8	16.08
	10.9	18.5	13.64	24.7	18.21	32	23.6
	12.9	21.6	15.93	28.9	21.31	37.5	27.66
M8	8.8	18.5	13.64	24.6	18.14	31.7	23.38
	10.9	27.2	20.06	36.1	26.62	46.4	34.22
	12.9	31.8	23.45	42.2	31.12	54.4	40.12
M10	8.8	36	26.55	48	35.4	62.8	46.32
	10.9	53	39.09	71	52.36	92.3	68.08

Sample manual. Download All 921 pages at:

<https://www.arepairmanual.com/downloads/abg8820-volvo-tracked-pavers-service-manual/>

M12	12.9	62	45.72	83	61.21	107	78.92
	8.8	63	46.46	84	61.95	108	79.66
	10.9	92	67.85	123	90.72	158.8	117.12
	12.9	108	79.65	144	106.20	185.5	136.82
M14	8.8	100	73.75	133	98.09	172.6	127.3
	10.9	146	107.68	195	143.82	252.9	186.53
	12.9	171	126.12	229	168.90	296.3	218.54
M16	8.8	153	112.84	206	151.93	268.6	198.11
	10.9	224	165.21	302	222.74	395.1	291.41
	12.9	262	193.24	354	261.09	462.5	341.12
M18	8.8	220	162.26	295	217.58	383.1	282.56
	10.9	314	231.59	421	310.51	546.5	403.08
	12.9	367	270.68	492	362.88	638.8	471.15
M20	8.8	308	227.16	415	306.08	542.8	400.35
	10.9	438	323.05	592	436.63	773.5	570.5
	12.9	513	378.36	692	510.39	904.6	667.2
M22	8.8	417	307.56	567	418.19	745.8	550.07
	10.9	595	438.84	807	595.21	1062.5	783.66
	12.9	696	513.34	945	696.99	1243.4	917.08
M24	8.8	529	390.17	714	526.61	933.2	688.29
	10.9	754	556.12	1017	750.1	1329.2	980.37
	12.9	882	650.52	1190	877.69	1555.4	1147.2
M27	8.8	772	569.39	1050	774.44	1382.8	1019.9
	10.9	1100	811.31	1496	1103.39	1969.8	1452.85
	12.9	1287	949.24	1750	1290.73	2304.9	1700
M30	8.8	1053	776.65	1428	1053.23	2090.8	1542.09
	10.9	1500	1106.34	2033	1499.46	2670.5	1969.66
	12.9	1755	1294.42	2380	1755.39	3125.5	2305.25

UNC threads, coarse pitch	Nm	lbf ft
1/4"	9 ±2	6.6 ±1.5
5/16"	18 ±4	13 ±3.0
3/8"	33 ±8	24 ±5.9
7/16"	54 ±14	40 ±10
1/2"	80 ±20	59 ±15
9/16"	120 ±30	89 ±22
5/8"	170 ±40	130 ±30
3/4"	300 ±70	220 ±52
7/8"	485 ±115	360 ±85
1"	725 ±175	530 ±130

Document Title: <b>Component locations</b>	Function Group: <b>030</b>	Information Type: <b>Service Information</b>	Date: <b>4/29/2026</b>
Profile: <b>ABG8820 Volvo PID:80673585</b>			

## Component locations

Showing Selected Profile

Valid for serial numbers			
Model	Production site	Serial number start	Serial number stop
ABG8820 Volvo PID:80673585			

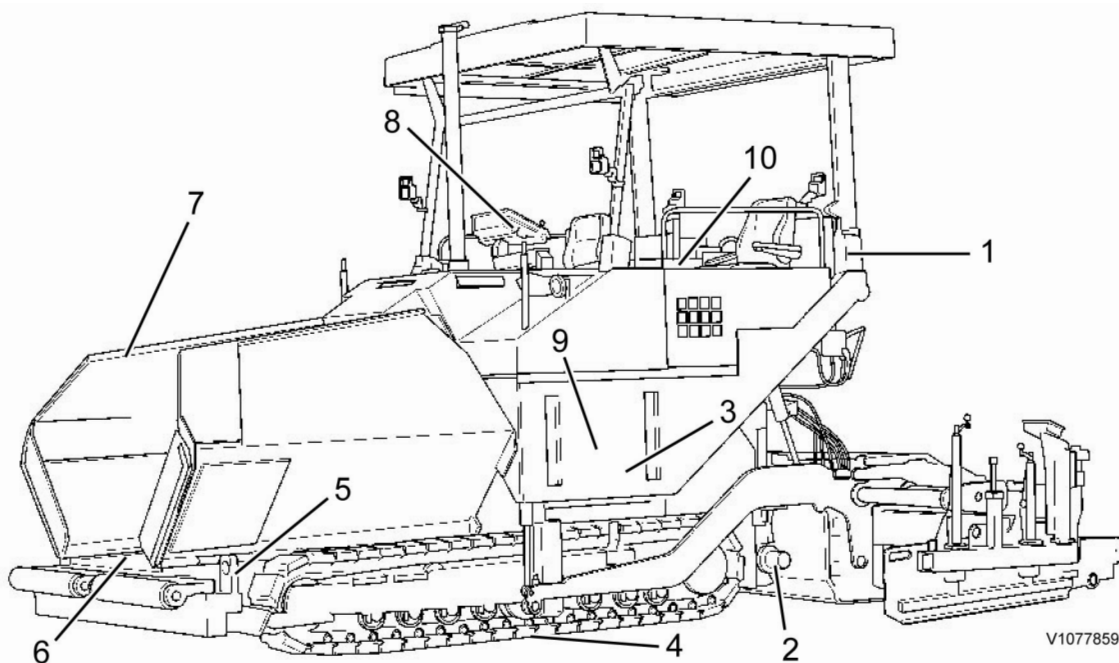

**Figure 1**  
Machine view

Position	Description
1	Superstructure
2	Auger
3	Hydraulic
4	Propulsion System
5	Frame
6	Conveyors
7	Hopper
8	Control panel
9	Drive
10	Electrics

Document Title: <b>Instruments and controls, overview</b>	Function Group: <b>030</b>	Information Type: <b>Service Information</b>	Date: <b>4/29/2026</b>
Profile: <b>ABG8820 Volvo PID:80673585</b>			

[Go back to Index Page](#)

## Instruments and operating controls, specifications

Showing Selected Profile

Valid for serial numbers			
Model	Production site	Serial number start	Serial number stop
ABG8820 Volvo PID:80673585			

Main control unit	
Function	Operate the machine yourself Indication, monitoring, data acquisition
Weight	12 kg (26 lb)
16 Keys	Menu navigation, input, figure pad
61 Keys	Direct machine operation
8 Keys	Menu-dependent alternating functions
27 LEDs status display	26 x green 1 x orange
6 LEDs error message display	red
Back lighting	LED, 24 V DC, adjustable light intensity
Test for keypad and LED status	via operating menu
Processor	Power PC
Clock frequency processor	266 MHz
Accumulator	64 MB RAM, 32 MByte Flash
Interfaces	1 x CAN 1 x Service
Operating voltage	15 - 30 V
Software	Linux-based
Display	TFT LCD, transfective
Dimension	26.4 cm (10.4 in)
Resolution	VGA 640 x 480 Pixel
Back lighting	LED-strip 2-sided
Light intensity	0 - 550 cd/m <sup>2</sup> adjustable
Interface	CMOS-RGB

Document Title: <b>Instruments and controls, overview</b>	Function Group: <b>030</b>	Information Type: <b>Service Information</b>	Date: <b>4/29/2026</b>
Profile: <b>ABG8820 Volvo PID:80673585</b>			

[Go back to Index Page](#)

## Instruments and operating controls, specifications

Showing Selected Profile

Valid for serial numbers			
Model	Production site	Serial number start	Serial number stop
ABG8820 Volvo PID:80673585			

Screed control unit	
Number of external control panels per machine	2
Function	Operate the machine yourself Optical feedback of switch states via LED Display of machine data
Weight	3.2 kg (7.1 lbs)
4 keys	Menu navigation, input
15 keys	Direct machine operation
4 LEDs status display	3 x green 1 x green/red
Back lighting	LED, 24 V DC, non-adjustable light intensity
Interfaces	1 x CAN
Operating voltage	24 V
Software	proprietary
Display	two-line monochrome background lit

Document Title: <b>Instruments and controls, overview</b>	Function Group: <b>030</b>	Information Type: <b>Service Information</b>	Date: <b>4/29/2026</b>
Profile: <b>ABG8820 Volvo PID:80673585</b>			

[Go back to Index Page](#)

## Instruments and operating controls, specifications

Showing Selected Profile

<b>Valid for serial numbers</b>			
<b>Model</b>	<b>Production site</b>	<b>Serial number start</b>	<b>Serial number stop</b>
ABG8820 Volvo PID:80673585			

<b>Auxiliary control panel</b>	
Function	Loading of machine onto transport vehicle Emergency operation together with external control panels if the control desk has failed
Weight	2.1 kg (4.6 lbs)
4 switches	Direct machine operation
2 potentiometer	Direct machine operation
Feed cable	2 m (6.6 ft.) firmly connected with housing
Housing	Stainless steel
Interfaces	analog and digital 17 pin connector
Operating voltage	15 - 30 V

Document Title: <b>Instruments and controls, overview</b>	Function Group: <b>030</b>	Information Type: <b>Service Information</b>	Date: <b>4/29/2026</b>
Profile: <b>ABG8820 Volvo PID:80673585</b>			

[Go back to Index Page](#)

## Instruments and operating controls, specifications

Showing Selected Profile

<b>Valid for serial numbers</b>			
<b>Model</b>	<b>Production site</b>	<b>Serial number start</b>	<b>Serial number stop</b>
ABG8820 Volvo PID:80673585			

<b>Emergency stop button</b>	
Switch module version	Normally closed
Switch module number	2
Protective functions	ISO 13850 EN 418 Forced opening to IEC/EN 60947-5-1
Weight	0.2 kg (0.44 lbs)

Document Title: <b>Instruments and controls, overview</b>	Function Group: <b>030</b>	Information Type: <b>Service Information</b>	Date: <b>4/29/2026</b>
Profile: <b>ABG8820 Volvo PID:80673585</b>			

[Go back to Index Page](#)

## Instruments and operating controls, specifications

Showing Selected Profile

Valid for serial numbers			
Model	Production site	Serial number start	Serial number stop
ABG8820 Volvo PID:80673585			

ThermoControl STC1600	
Measurement range	0–250°C ± 2°C
Temperature control range	30–180°C Hysteresis: -2°C
inputs	4 connections for PT100 sensors
Outputs	4 channels, each 1x blower and 1x burner max 0.5 A permanent per channel short-circuit resistant
Operating voltage	11 - 30 V DC
Temperature	Operation: +5 °C — +60 °C (+40 °F — +140 °F) Storage: -20°C — +70°C (-4 °F — +160 °F)
Humidity	max 95% relative humidity, non-condensing
Ground	Switch cabinet: 130 mm x 105 mm x 75 mm (5 in x 4 in x 3 in)
Weight	Switch cabinet: 950 g (2.1 lb)

Document Title: <b>Conversion tables</b>	Function Group: <b>030</b>	Information Type: <b>Service Information</b>	Date: <b>4/29/2026</b>
Profile: <b>ABG8820 Volvo PID:80673585</b>			

## Conversion tables

Showing Selected Profile

Valid for serial numbers			
Model	Production site	Serial number start	Serial number stop
ABG8820 Volvo PID:80673585			

### Length

Unit	cm	m	km	in	ft	yd	mile
cm	1	0.01	0.00001	0.3937	0.03281	0.01094	0.000006
m	100	1	0.001	39.37	3.2808	1.0936	0.00062
km	100000	1000	1	39370.7	3280.8	1093.6	0.62137
in	2.54	0.0254	0.000025	1	0.08333	0.02777	0.000015
ft	30.48	0.3048	0.000304	12	1	0.3333	0.000189
yd	91.44	0.9144	0.000914	36	3	1	0.000568
mile	160930	1609.3	1.6093	63360	5280	1760	1

1 mm = 0.1 cm - 1 mm = 0.001 m

### Area

Unit	cm <sup>2</sup>	m <sup>2</sup>	km <sup>2</sup>	a	ft <sup>2</sup>	yd <sup>2</sup>	in <sup>2</sup>
cm <sup>2</sup>	1	0.0001	-	0.000001	0.001076	0.000012	0.155000
m <sup>2</sup>	10000	1	0.000001	0.01	10.764	1.1958	1550.000
km <sup>2</sup>	-	1000000	1	10000	1076400	1195800	-
a	0.01	100	0.0001	1	1076.4	119.58	-
ft <sup>2</sup>	-	0.092903	-	0.000929	1	0.1111	144.000
yd <sup>2</sup>	-	0.83613	-	0.008361	9	1	1296.00
in <sup>2</sup>	6.4516	0.000645	-	-	0.006943	0.000771	1

1 ha = 100 a - 1 mile<sup>2</sup> = 259 ha = 2.59 km<sup>2</sup>

### Volume

Unit	cm <sup>3</sup> = cc	m <sup>3</sup>	l	in <sup>3</sup>	ft <sup>3</sup>	yd <sup>3</sup>
cm <sup>3</sup> = ml	1	0.000001	0.001	0.061024	0.000035	0.000001
m <sup>3</sup>	1000000	1	1000	61024	35.315	1.30796
dm <sup>3</sup> (l)	1000	0.001	1	61.024	0.035315	0.001308
in <sup>3</sup>	16.387	0.000016	0.01638	1	0.000578	0.000021
ft <sup>3</sup>	28316.8	0.028317	28.317	1728	1	0.03704
yd <sup>3</sup>	764529.8	0.76453	764.53	46656	27	1

1 gal (US) = 3785.41 cm<sup>3</sup> = 231 in<sup>3</sup> = 0.83267 gal (UK)

### Weight

Unit	g	kg	t	oz	lb
g	1	0.001	0.000001	0.03527	0.0022
kg	1000	1	0.001	35.273	2.20459
t	1000000	1000	1	35273	2204.59
oz	28.3495	0.02835	0.000028	1	0.0625
lb	453.592	0.45359	0.000454	16	1

1 ton (metric) = 1.1023 ton (US) = 0.9842 ton (UK)

### Pressure

Unit	kp/cm <sup>2</sup>	bar	Pa=N/m <sup>2</sup>	kPa	lbf/in <sup>2</sup>	lbf/ft <sup>2</sup>
kp/cm <sup>2</sup>	1	0.98067	98066.5	98.0665	14.2233	2048.16
bar	1.01972	1	100000	100	14.5037	2088.6
Pa=N/m <sup>2</sup>	0.00001	0.001	1	0.001	0.00015	0.02086
kPa	0.01020	0.01	1000	1	0.14504	20.886
lbf/in <sup>2</sup>	0.07032	0.0689	6894.76	6.89476	1	144
lbf/ft <sup>2</sup>	0.00047	0.00047	47.88028	0.04788	0.00694	1

kg/cm<sup>2</sup> = 735.56 Dry (mmHg) = 0.96784 atm

### Unit explanations

Unit	abbreviation
Newton meter	Nm
Kilopoundmeter	kpm
Kilopascal	kPa
Megapascal	MPa
Kilowatt	kW
kilojoule	kJ
British thermal unit	Btu
Calorie	cal

### Approx. conversion

SI unit	Conversion factor	Non SI	Conversion factor	SI
<b>Torque</b>				
Nm	x10.2	=kg/cm	x0.8664	=lb in
Nm	x0.74	=lbf-ft	x1.36	=Nm
Nm	x0.102	=kg/m	x7.22	=lbft
<b>Pressure (Pa = N/m<sup>2</sup>)</b>				
kPa	x4.0	=in.H <sub>2</sub> O	x0.249	=kPa
kPa	x0.30	=in.Hg	x3.38	=kPa
kPa	x0.145	=psi	x6.89	=kPa
bar	x14.5	=psi	x0.069	=bar
kp/cm <sup>2</sup>	x14.22	=psi	x0.070	=kp/cm <sup>2</sup>
N/mm <sup>2</sup>	x145.04	=psi	x0.069	=bar
MPa	x145	=psi	x0.00689	=MPa
<b>Power (W = J/s)</b>				
kW	x1.36	=hp(cv)	x0.736	=kW

kW	x1.34	= bhp	x0.746	= kW
kW	x0.948	= Btu/s	x1.055	= kW
W	x0.74	= ft-lb/s	x1.36	= W
Energy (J = Nm)				
kJ	x0.948	= Btu	x1.055	= kJ
J	x0.239	= calorie	x4.19	= J
Speed and acceleration				
m/s <sup>2</sup>	x3.28	= ft/s <sup>2</sup>	x0.305	= m/s <sup>2</sup>
m/s	x3.28	= ft/s	x0.305	= m/s
km/h	x0.62	= mph	x1.61	= km/h
Horsepower/torque				
Bhp x5252 rpm= TQ (lb-ft)			TQ x rpm 5252=bhp	
Temperature				
$^{\circ}\text{C} = (^{\circ}\text{F} - 32) / 1.8$			$^{\circ}\text{F} = (^{\circ}\text{C} \times 1.8) + 32$	
Flow factor				
l/min (dm <sup>3</sup> /min)	x0.264	= US gal/min	x3.785	= liter/min

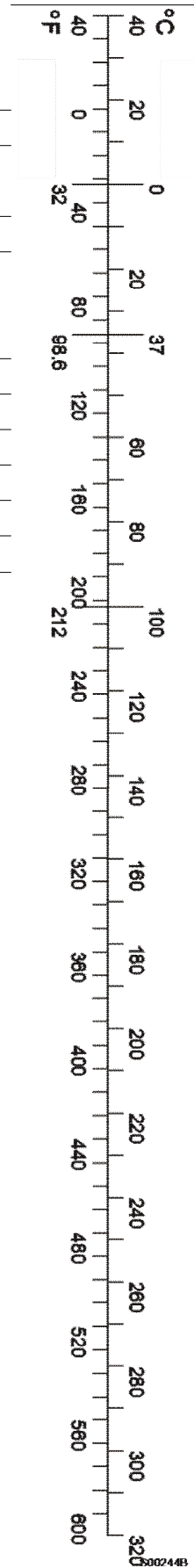

Document Title: <b>Transporting the machine</b>	Function Group: <b>050</b>	Information Type: <b>Service Information</b>	Date: <b>4/29/2026</b>
Profile: <b>ABG8820 Volvo PID:80673585</b>			

## Machine, transporting

Showing Selected Profile

Valid for serial numbers			
Model	Production site	Serial number start	Serial number stop
ABG8820 Volvo PID:80673585			

### **WARNING**

If the machine is to be driven from a loading dock onto the platform of a truck trailer or railway car, make sure that the vehicle is securely braked, for example, wheels blocked. Make sure that there is no risk that the vehicle cannot roll over or sway in a dangerous manner when the machine is driven on.

- Raise auger to top position.
- Move the screed into the transport position and lock it in the transport attachment.
- Drive machine onto transport vehicle.

#### **NOTE!**

Drive straight onto the transport vehicle so that the machine cannot slip sideways from the ramp.

- Lower screed onto transport vehicle.
- Turn off the engine.
- Remove main control panel and external control panels and store securely.
- Flap down the all-weather roof.
- Withdraw battery isolation switch.
- Lash machine securely to transport vehicle.

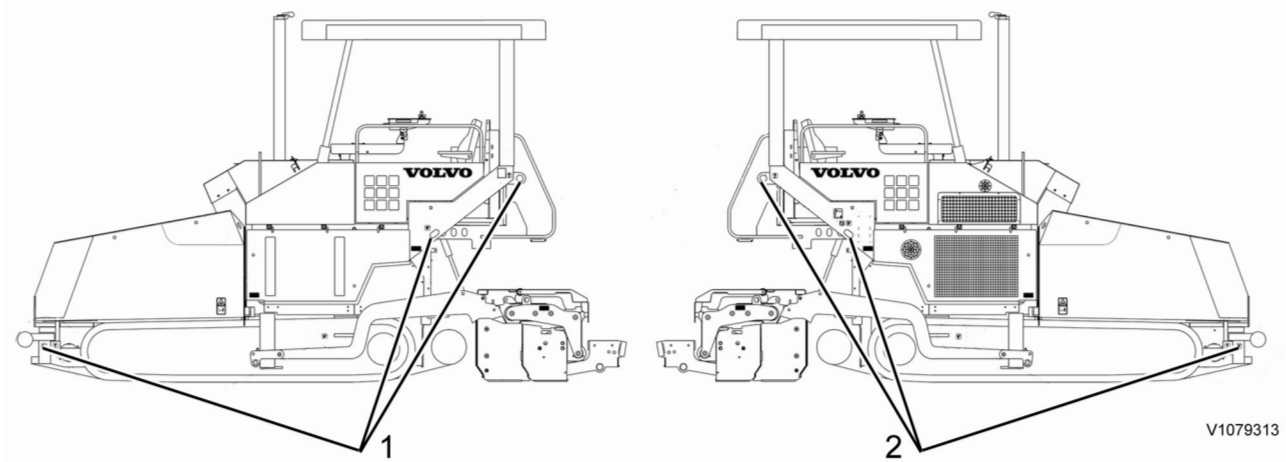

V1079313

**Figure 1**  
Lashing points

Position	Description
1	Machine lashing points, left (LH)
2	Machine lashing points, right (RH)

Secure (lash) the machine to the loading platform of the transport vehicle so it cannot tip over or roll away.



Marker plate for lashing

**Lifting of machine**

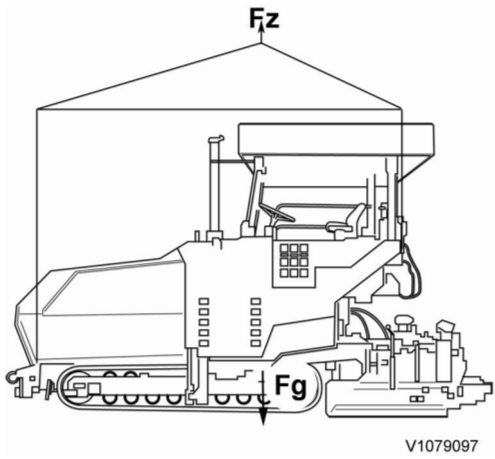

V1079097

**Figure 2**

Lifting of machine

Position	Descriptions
Fg	Centre of gravity
Fz	Tractive power

To raise the machine, use the stop points provided. Stop points: see picture.



Marking plate - Load/lift

Document Title: <b>Operation numbers for additional work</b>	Function Group: <b>070</b>	Information Type: <b>Service Information</b>	Date: <b>4/29/2026</b>
Profile: <b>Tracked Pavers (PAT)</b>			

## Operation numbers for additional work

Showing Selected Profile

These operations can be used to identify work that is not included in the time guide or described in the methods in the Service Manual. When these operations are used, a description of the work that has been performed must be provided.

### Other work related to engine

Op. no. 070-210

This operation can be used when work has been done related to the engine and function group 2 when no applicable method description was available. When this operation is used, additional information is required:

- Description of work that has been done

### Other work related to electrical system

Op. no. 070-310

This operation can be used when work has been done related to the electrical system and function group 3 when no applicable method description was available. When this operation is used, additional information is required:

- Description of work that has been done

### Other work related to transmission, gearbox, travel motor, swing motor

Op. no. 070-410

This operation can be used when work has been done related to the transmission, gearbox, travel motor or swing motor and function group 4 when no applicable method description was available. When this operation is used, additional information is required:

- Description of work that has been done

### Other work related to drive axle

Op. no. 070-470

This operation can be used when work has been done related to the drive axle and function group 46 when no applicable method description was available. When this operation is used, additional information is required:

- Description of required work that have been done

### Other work related to brake system

Op. no. 070-510

This operation can be used when work has been done related to the brake system and function group 5 when no applicable

method description was available. When this operation is used, additional information is required:

- Description of work that has been done

**Other work related to steering system**

Op. no. 070-610

This operation can be used when work has been done related to the steering system and function group 6 when no applicable method description was available. When this operation is used, additional information is required:

- Description of work that has been done

**Other work related to frame link, axle suspension**

Op. no. 070-710

This operation can be used when work has been done related to the frame link, axle suspension and other parts related to function group 7 when no applicable method description was available. When this operation is used, additional information is required:

- Description of work that has been done

**Other work related to cab, air conditioning**

Op. no. 070-810

This operation can be used when work has been done related to the cab, air conditioning and other parts related to function group 8 when no applicable method description was available. When this operation is used, additional information is required:

- Description of work that has been done

**Other work related to hydraulic system**

Op. no. 070-910

This operation can be used when work has been done related to the hydraulic system and other parts related to function group 9 when no applicable method description was available. When this operation is used, additional information is required:

- Description of work that has been done

Document Title: <b>E-7006</b>	Function Group: <b>080</b>	Information Type: <b>Service Information</b>	Date: <b>4/29/2026</b>
Profile: <b>ABG8820 Volvo PID:80673585</b>			

### E-7006

Showing Selected Profile

Valid for serial numbers			
Model	Production site	Serial number start	Serial number stop
ABG8820 Volvo PID:80673585			

All dimensions in mm.

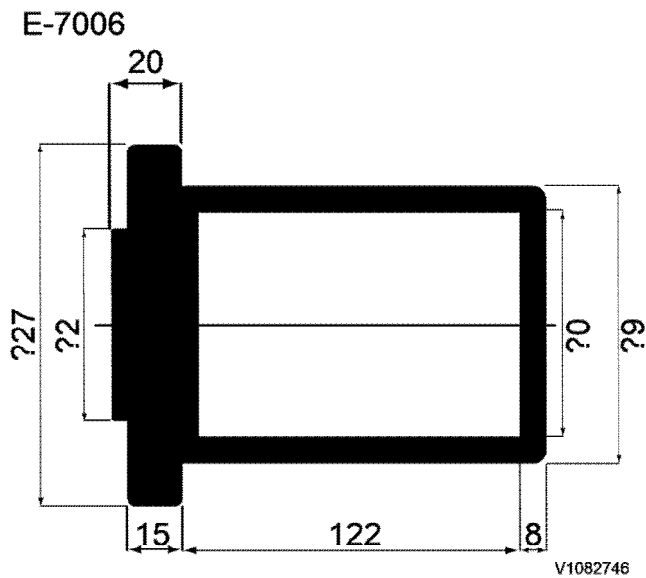

#### Figure 1

E-7006 Drift

Material: S355 JR or better.

Document Title: <b>E-7008</b>	Function Group: <b>080</b>	Information Type: <b>Service Information</b>	Date: <b>4/29/2026</b>
Profile: <b>ABG8820 Volvo PID:80673585</b>			

### E-7008

Showing Selected Profile

Valid for serial numbers			
Model	Production site	Serial number start	Serial number stop
ABG8820 Volvo PID:80673585			

All dimensions in mm.

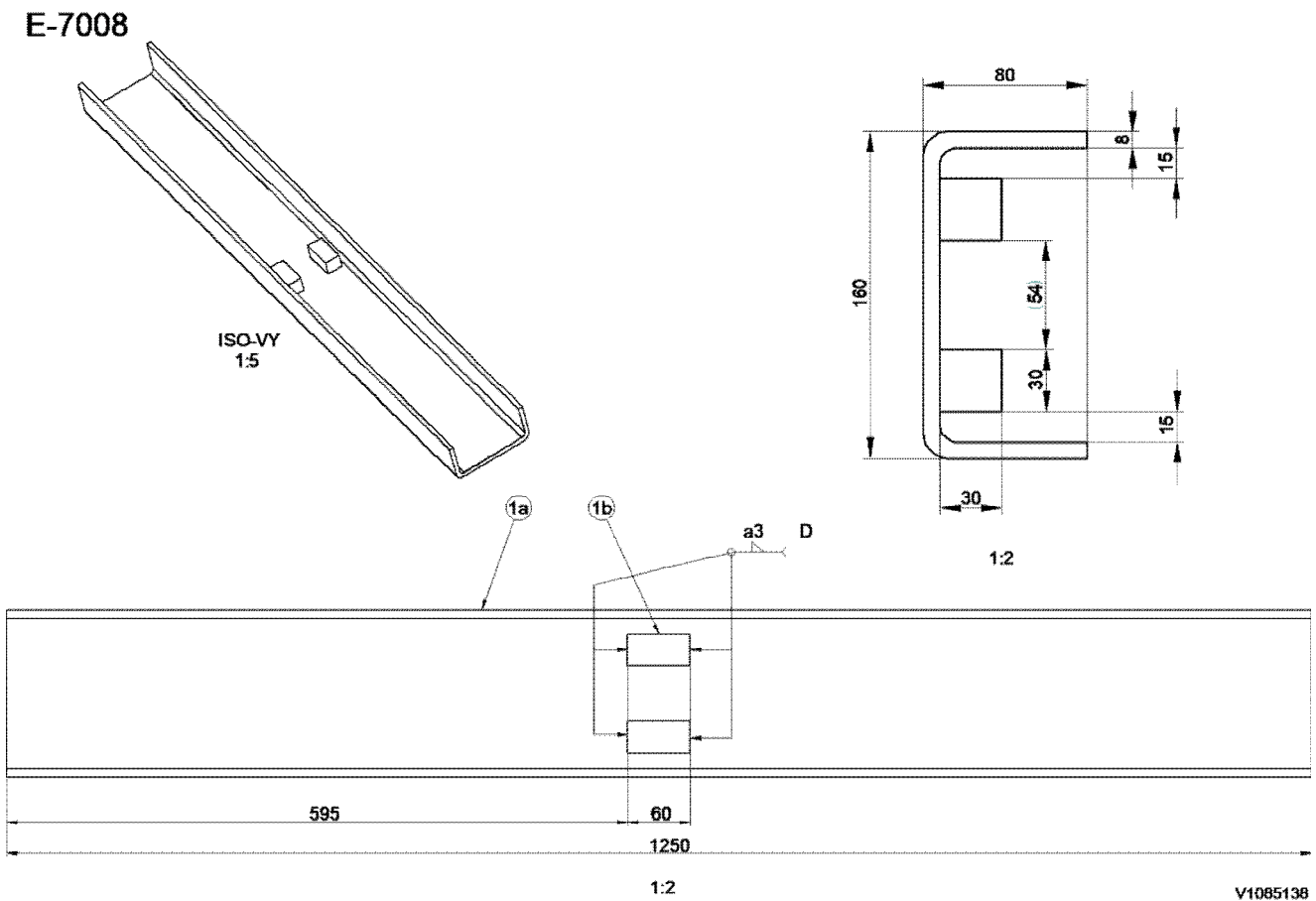

**Figure 1**  
E-7008 U bar  
Material: S355 JR or better.

Document Title: <b>E-7009</b>	Function Group: <b>080</b>	Information Type: <b>Service Information</b>	Date: <b>4/29/2026</b>
Profile: <b>ABG8820 Volvo PID:80673585</b>			

### E-7009

Showing Selected Profile

Valid for serial numbers			
Model	Production site	Serial number start	Serial number stop
ABG8820 Volvo PID:80673585			

All dimensions in mm.

#### E-7009

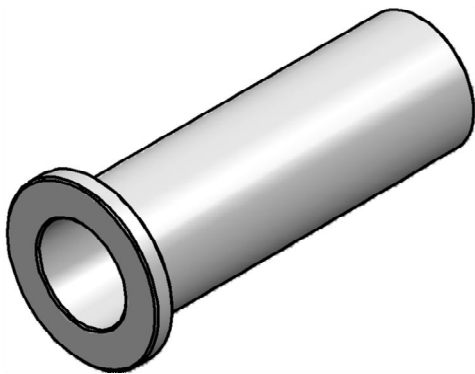
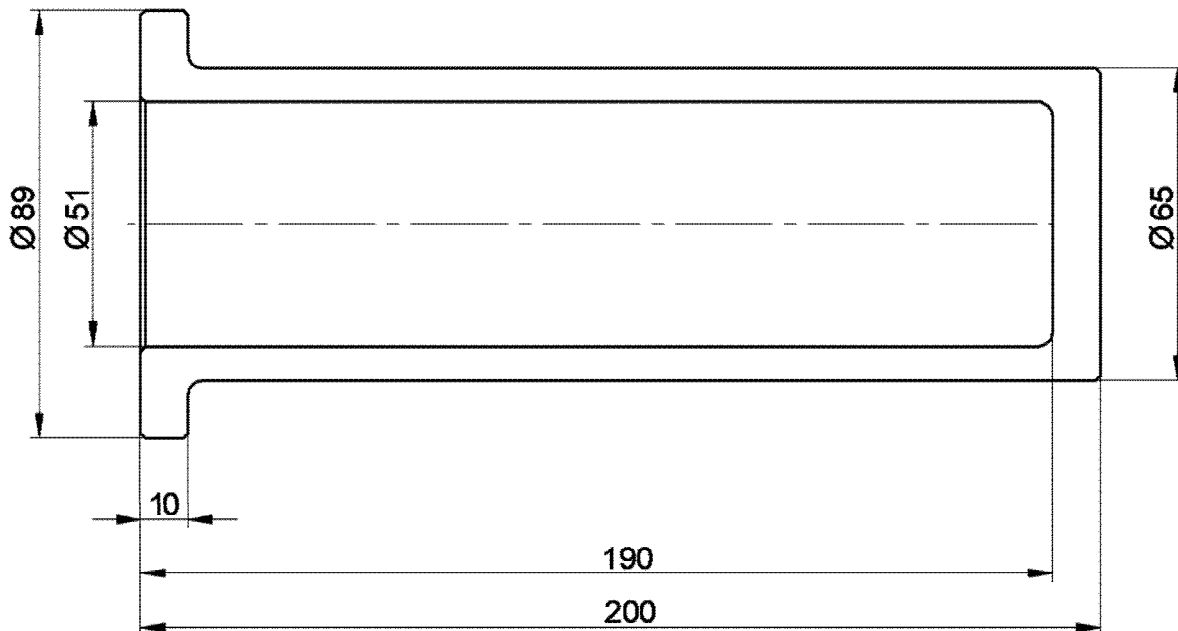

V1086432

**Figure 1**

E-7009 Drift

Material: S355 JR or better.

Document Title: <b>E-7014</b>	Function Group: <b>080</b>	Information Type: <b>Service Information</b>	Date: <b>4/29/2026</b>
Profile: <b>ABG8820 Volvo PID:80673585</b>			

**E-7014**

Showing Selected Profile

<b>Valid for serial numbers</b>			
<b>Model</b>	<b>Production site</b>	<b>Serial number start</b>	<b>Serial number stop</b>
ABG8820 Volvo PID:80673585			

All dimensions in mm.

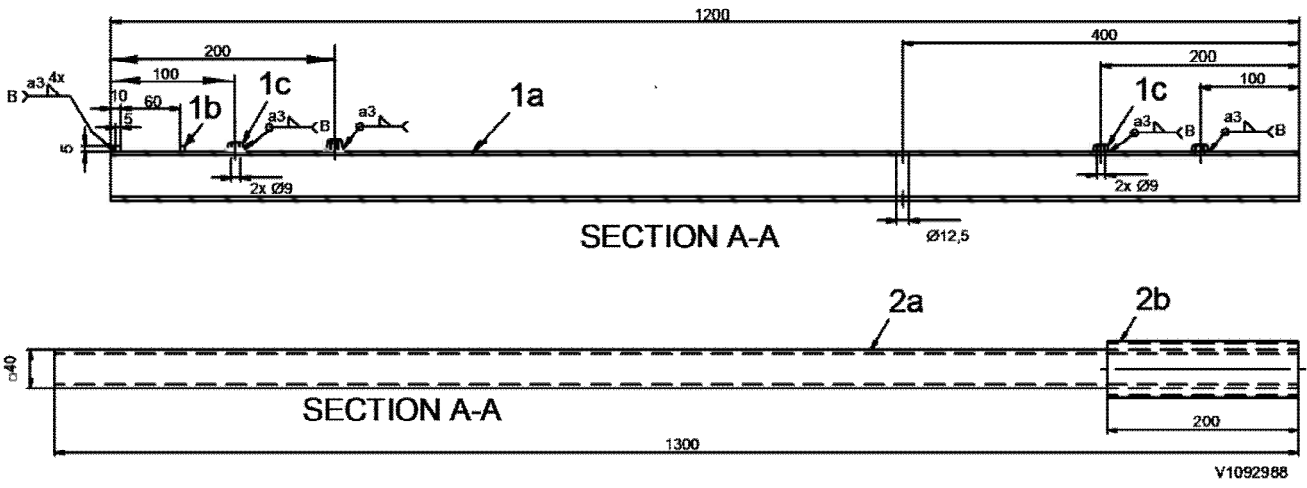
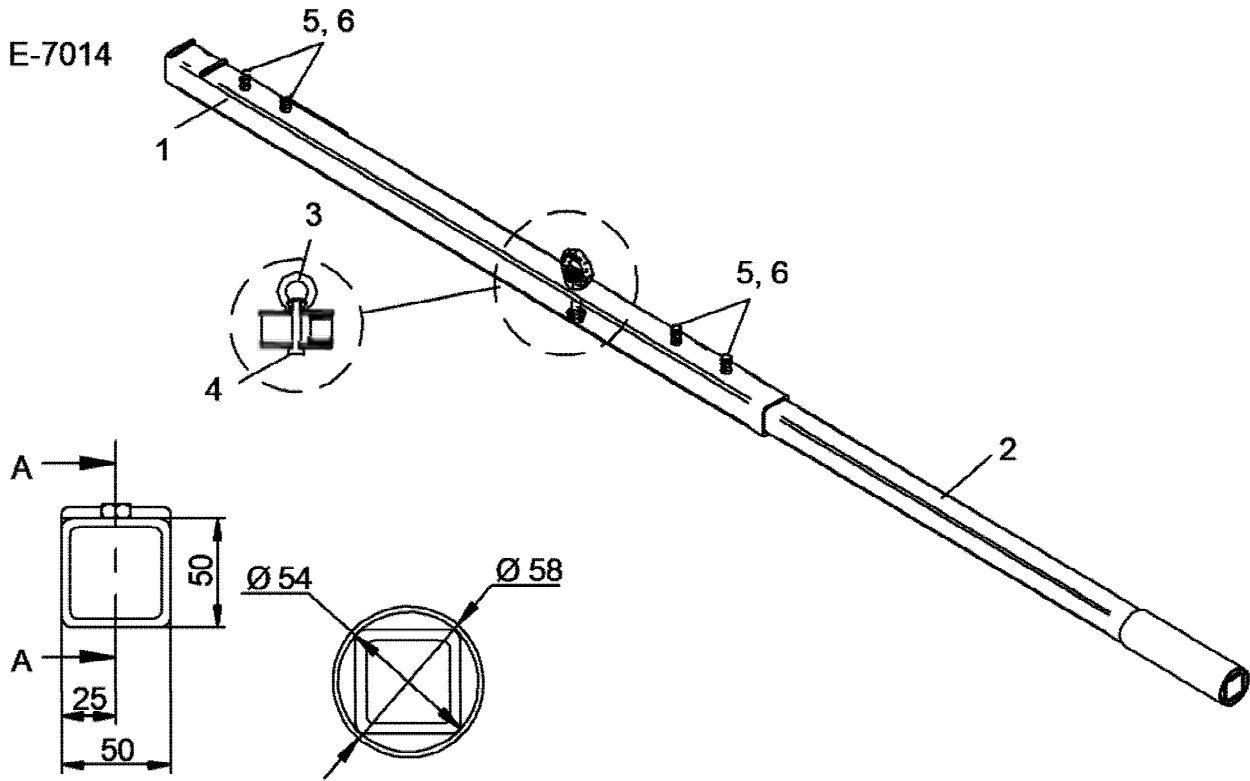

V1092988

**Figure 1**  
E-7014 Lifting tool

Pos.	Qty.	Material	Part name
1a	1	S235JR	KKR 50 x 50 x 4
1b	2	2142-01	5 x 5 x 50
1c	2	Nut	M8
2a	1	S235JR	KKR 40 x 40 x 3
2b	1	2142-01	-
3	1	Screw-in eyelet	M12
4	1	Screw	M6SF M12 x 65
5	2	Screw	M6S M8 x 25
6	2	Nut	M6M M8

Document Title: <b>Lubricants, service capacities and intervals</b>	Function Group: <b>160</b>	Information Type: <b>Service Information</b>	Date: <b>4/29/2026</b>
Profile: <b>ABG8820 Volvo PID:80673585</b>			

## Lubricants, service capacities and intervals

Showing Selected Profile

Valid for serial numbers			
Model	Production site	Serial number start	Serial number stop
ABG8820 Volvo PID:80673585			

Description	Used for	Quantity	Specification	VOLVO Part no.	Change intervals
Engine oil	Engine	19 litres	SAE 10W-40 ACEA E6 / E7	11988175	every 500 hours
Hydraulic oil	Hydraulic system	190 litres	HVLP 100, DIN 51524-3	RM80635402	every 1000 hours
Transmission oil	Travel gearbox	6 litres	Shell Spirax MB90 <b>Do not use limited slip (LS) transmission oil!</b>	RM13923131	Warranty inspection, first 100 operating hours every 1000 hours
	Pump distributor gear	2 litres			
	Worm gear	2 litres			
Grease	Auger bearings Conveyor bearings remaining grease points	as required	Volvo high temperature grease	RM80795826	-
Fuel	Engine (fuel tank)	300 litres	CEN EN 590 DIN 51601 BS 2869: A1; A2 ASTM D975-88: 1-D, 2-D NATO Code: F54. F-75	-	-
Coolant	Engine (radiator)	20 litres	BASF Glysantin G48 Antifreeze protection to -35 °C <b>NOTE!</b> Do not mix coolants! Use Volvo Coolant VCS only for complete fresh fill.	RM56246853	every 4000 hours

Document Title: <b>Alternative fuels</b>	Function Group: <b>160</b>	Information Type: <b>Service Information</b>	Date: <b>4/29/2026</b>
Profile: <b>Tracked Pavers (PAT)</b>			

## Alternative fuels

Showing Selected Profile

**This statement is only valid for Volvo branded engines.**

Hydro-treated vegetable oil (HVO) and fatty acid methyl ester (FAME) biodiesel are both made from renewable raw materials such as vegetable oils and animal fats, but they are chemically processed in different ways.

### Hydro-treated vegetable oil (HVO)

HVO is created using a chemical process called hydro-treating. Hydro-treating creates an oxygen-free hydrocarbon product that is very similar to distillate diesel fuel and is well suited for use in diesel engines. HVO fuels complying with the CEN diesel fuel standard EN 590:2013 or with the European Fuel Quality Directive 98/70/EC are approved for use in all Volvo Construction Equipment diesel engines with no changes to maintenance intervals. Paraffinic diesel fuels complying with the CEN standard EN 15940 may be used in all machines operating outside the European Union and for EU-certified engines up to the emission level Stage IV. These fuels may also be used for the EU-certified D11, D13 and D16 engines meeting the emission level Stage V.

### Biodiesel

Biodiesel is a product made from renewable resources such as vegetable oils or animal fat. Biodiesel that has been chemically processed into fatty acid methyl ester (FAME) can be blended with distillate diesel fuel and used in some diesel engines. Unblended biodiesel is referred to as B100 because it is 100% biodiesel.

Rapeseed methyl ester (RME) is the most common type of FAME used in Europe. Soy methyl ester (SME) and sunflower oil methyl ester (SOME) are the most common types of FAME used in the US.

Although use of FAME biodiesel is now a legal requirement in some markets, it is not as suitable for use in diesel engines as conventional diesel fuel or HVO (hydro-treated vegetable oil).

### Biodiesel fuel requirements

The FAME biodiesel blends specified in the table below are approved for use if:

- The biodiesel is pre-blended by the fuel supplier
- The biodiesel used in the blend conforms to EN14214 or ASTM D6751
- The distillate fuel used in the blend meets fuel sulphur requirements
- The distillate fuel used in the blend conforms to EN590 or ASTM D975
- B1-B5 biodiesel blends conform to EN590 or ASTM D975
- B6-B7 biodiesel blends conform to EN590 or ASTM D7467
- B8-B20 biodiesel blends conform to EN16709(B20) or ASTM D7467

Engine emission designation	Engine size	Acceptable blend
EU Stage II / US Tier 2 * EU Stage IIIA / US Tier 3 * EU Stage IIIB / US Tier 4 interim EU Stage IV / US Tier 4 final EU Stage V	Below D4 / 4 litres	Up to B7
EU Stage II / US Tier 2 * EU Stage IIIA / US Tier 3 * EU Stage IIIB / US Tier 4 interim EU Stage IV / US Tier 4 final	D4–D8	Up to B7
EU Stage II / US Tier 2 * EU Stage IIIA / US Tier 3 * US Tier 4 final, special North America arrangement **	D9–D16	Up to B20
EU Stage IIIB / US Tier 4 interim EU Stage IV / US Tier 4 final	D11–D16	Up to B10

EU Stage IIIB / US Tier 4 interim, equipped with High Sulphur Fuel Conversion Kit (only available in unregulated markets)	D4–D16	Up to B20
EU Stage IV / US Tier 4 final, equipped with High Sulphur Fuel Conversion Kit (only available in unregulated markets)		
EU Stage V	D4–D16	Up to B7
* As Tier 2 and Tier 3 emissions regulations ended in 2005 and 2010 respectively, engines produced since then typically <b>meet Stage II / Stage IIIA regulations</b> , allowing their sale in less regulated markets.		
** With additional restrictions and special operating conditions, equipment used in North America may operate on B20 diesel.		

#### NOTE!

Failures directly caused by the use of poor quality biofuel, or any other fuel not conforming to standards, are not factory defects and the manufacturer's warranty does not apply.

#### Maintenance interval requirements

Additional service actions and shorter maintenance intervals are mandatory when using biodiesel blends above B10.

<b>Every 10 hours</b>
<ul style="list-style-type: none"> <li><input type="radio"/> Check the engine oil and change if it rises above the maximum fill level</li> <li><input type="radio"/> Inspect the fuel system components and replace as necessary</li> </ul>
<b>Half of original interval</b>
<ul style="list-style-type: none"> <li><input type="radio"/> Change the engine oil and filter</li> <li><input type="radio"/> Replace the fuel filter(s)</li> </ul>
<b>Every year, regardless of operating hours</b>
<ul style="list-style-type: none"> <li><input type="radio"/> Change the engine oil and filter</li> <li><input type="radio"/> Clean the fuel tank</li> </ul>

#### Effects of biodiesel on engine oil

Using biodiesel can lead to increased oil dilution. Use engine oil analysis tools frequently to check for fuel dilution and monitor engine oil condition. Check the engine oil level daily. Always change the engine oil if the oil level rises above the maximum fill level.

#### Effects of biodiesel on fuel systems

Biodiesel dissolves and loosens some fuel system deposits. During the initial conversion to biodiesel, loosened deposits will travel to the fuel filters and require more frequent fuel filter replacements. Start with new fuel filters when using biodiesel for the first time.

Biodiesel is aggressive to some materials used in fuel system components. Inspect seals, hoses, rubber and plastic components every 10 hours. Repair or replace any components that are damaged, softened or leaking. Clean biodiesel from painted surfaces immediately to prevent paint damage.

Biodiesel is more sensitive to bacteria and water contamination than distillate diesel fuel.

- Use as much fuel as possible before refilling the fuel tank in order to prevent bacteria growth if a machine is in regular use, e.g. regularly uses up a tank of fuel within a week. In climates where condensation is a risk, or when the machine is working for short durations, keep the fuel tank full.
- Do not use biodiesel in machines with low utilization or operating time.
- Do not store machines for more than 4 weeks without flushing biodiesel out of the fuel system by operating the machine through at least one full tank of distillate diesel fuel.
- Always follow the manufacturer's storage recommendations and "best-before" dates for each delivery of biodiesel.

#### Effects of biodiesel on exhaust aftertreatment systems

Biodiesel leaves higher levels of ash in diesel particulate filters and may require more frequent diesel particulate filter (DPF) regeneration and cleaning. Biodiesel can cause deviations in temperatures and functionality of the DPF burner and may cause fault codes or errors.

Biodiesel exhaust gas is aggressive to some materials used in selective catalytic reduction systems (SCR) and may require more frequent cleaning, repairing or replacing of SCR parts.

**Effects of biodiesel on cold weather operation**

Biodiesel has a high viscosity at temperatures below 0 °C (32 °F) and may cause problems starting the engine. Use a fuel heater or park machines in a heated building if possible.

**Effects of biodiesel on engine performance**

Biodiesel B100 has about 8% lower energy density compared to regular diesel fuel. Blends equal or lower than B20 have a small impact on engine performance.

**Effects of biodiesel on emissions compliance**

Engines are certified to comply with U.S. EPA, California and EU emissions standards based upon the use of test fuels with specifications established by these regulatory agencies. Alternative fuels, including biodiesel, that are not substantially similar to the required test fuels may adversely affect engine emissions compliance. As a result, Volvo does not warrant that the engine will conform to applicable Federal or California and EU emissions limits when operated on, or having previously being operated on, biodiesel or other alternative fuels that are not substantially similar to specified test fuels used for certification, nor if biodiesel / regular diesel is used in blends that exceed the recommendations.

However, the use of biodiesel up to a maximum of 20% (B20) in and of itself, will not affect the manufacturer's mechanical warranty as to engine or emissions system, provided the bio fuel used in the blend conforms to the applicable standards and the additional steps outlined herein are followed.

Document Title: <b>Coolant</b>	Function Group: <b>160</b>	Information Type: <b>Service Information</b>	Date: <b>4/29/2026</b>
Profile: <b>ABG8820 Volvo PID:80673585</b>			

## Coolant

Showing Selected Profile

Valid for serial numbers			
Model	Production site	Serial number start	Serial number stop
ABG8820 Volvo PID:80673585			

To avoid damage to the engine from frost, corrosion and cavitation, it is very important to treat the coolant liquid appropriately and check it. The following mixing ratio is recommended when concentrated coolant and clean water are used:

Anti-freeze protection to	Proportion of concentrated coolant	Water proportion
-22 °C	min. 35%	65%
-28 °C	40%	60%
-35 °C	max.45%	55%

The water quality is very important for the treatment of the coolant and must show the following properties:

Properties	min.	max.
pH-value at 20°C	6.5	8.5
Chloride-ion content (mg/dm <sup>3</sup> )	—	100
Sulphate-ion content (mg/dm <sup>3</sup> )	—	100
Total hardness	3	12

In the event of deviations of the values, the water must be treated in line with the admissible values. In the case of any uncertainty regarding the water quality, a fully mixed coolant must be used.

Document Title: <b>Arrival Inspection, according to Inspection Programme</b>	Function Group: <b>171</b>	Information Type: <b>Service Information</b>	Date: <b>4/29/2026</b>
Profile: <b>Tracked Pavers (PAT)</b>			

## **Arrival Inspection, according to Inspection Programme**

**Op nbr 171-001**

**Total procedure time (hr): 0.80**

1. This Inspection Programme can be found as a PDF file in the document library in PROSIS.

Document Title: <b>Delivery Inspection, according to Inspection Programme</b>	Function Group: <b>171</b>	Information Type: <b>Service Information</b>	Date: <b>4/29/2026</b>
Profile: <b>Tracked Pavers (PAT)</b>			

## **Delivery Inspection, according to Inspection Programme**

**Op nbr 171-002**

**Total procedure time (hr): 1.75**

1. This Inspection Programme can be found as a PDF file in the document library in PROSIS.

Document Title: <b>Maintenance of Stored Machines, according to Inspection Programme</b>	Function Group: <b>171</b>	Information Type: <b>Service Information</b>	Date: <b>4/29/2026</b>
Profile: <b>Tracked Pavers (PAT)</b>			

## **Maintenance of Stored Machines, according to Inspection Programme**

**Op nbr 171-003**

**Total procedure time (hr): 2.50**

1. This Inspection Programme can be found as a PDF file in the document library in PROSIS.

Document Title: <b>Warranty inspection, 100 hours</b>	Function Group: <b>172</b>	Information Type: <b>Service Information</b>	Date: <b>4/29/2026</b>
Profile: <b>ABG8820 Volvo PID:80673585</b>			

## Warranty inspection 100 hours

Showing Selected Profile

Valid for serial numbers			
Model	Production site	Serial number start	Serial number stop
ABG8820 Volvo PID:80673585			

### Op nbr 172-002

1. Move the machine to service position 1, see [Service positions, overview](#).
2. Change pump distributor gear oil; see [Transmission, changing oil](#).
3. Change fuel filter (prefilter and fine filter); see [Fuel filter, replacing](#) and [Fine fuel filter](#).
4. Change transmission oil, see [Oil level](#).
5. Check worm drive chain; see [Auger drive chain tension, checking](#).
6. Change worm gear oil; see [Auger drive planetary oil, changing](#).
7. Drain water from worm chain channel; see [Chain channel, draining](#).
8. Check battery; see [Batteries](#).
9. Check V-belt (alternator) tension; see [Alternator belt, checking](#) and [Alternator belt, adjusting](#).