

Document Title: Description	Function Group: 000	Information Type: Service Information	Date: 4/29/2026
Profile: ABG5820 Volvo PID:80690332			

Description

Showing Selected Profile

Valid for serial numbers			
Model	Production site	Serial number start	Serial number stop
ABG5820 Volvo PID:80690332			

The machine is designed for application of all types of graded asphalt aggregates, hydraulically bonded graded aggregates, graded ballast, sand or gravel.

The engine is a four-cylinder, four-stroke, in-line diesel engine with direct injection and water cooling.

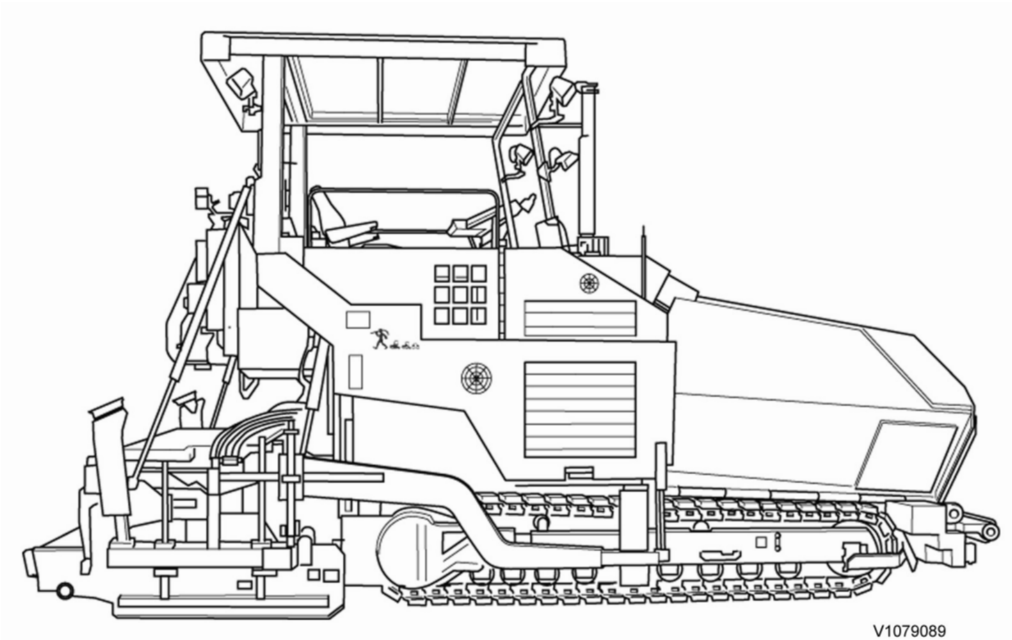

Figure 1
General View

Document Title: Standard tightening torques	Function Group: 030	Information Type: Service Information	Date: 4/29/2026
Profile: ABG5820 Volvo PID:80690332			

Standard tightening torques

Showing Selected Profile

Valid for serial numbers			
Model	Production site	Serial number start	Serial number stop
ABG5820 Volvo PID:80690332			

Tightening torques in the following tables refer to bolted joints with tensile strength according to the below. The tables should be regarded as general guidelines for tightening bolted joints where nothing else is specified.

NOTE!

Increase the values by 10% for flange bolt type U6FS. Bolts and nuts should be clean and lubricated with oil.

Surface coating		Coefficient of friction	
Non-electrolytic zinc plate coatings	ISO10683-FLZN/ZN/TL/480	0.08	
	ISO10683-FLZN/ZN/TL/720		
	(ISO10683) Geomet 500A		
Yellowish iridescent	ISO4042-A2C	0.12	
Electrolytic coating	ASTMF 1941 Fe/Zn5ANS	0.24	

Dimension s	Strength classes	Coefficient of friction					
		0.08		0.12		0.24	
		Tightening torque (Nm)	Tightening torques: (lbf ft)	Tightening torque (Nm)	Tightening torques: (lbf ft)	Tightening torque (Nm)	Tightening torques: (lbf ft)
M4	8.8	2.3	1.7	3	2.21	3.8	2.8
	10.9	3.3	2.43	4.6	3.39	5.5	4.06
	12.9	3.9	2.87	5.1	3.76	6.5	4.79
M5	8.8	4.4	3.24	5.9	4.35	7.5	5.53
	10.9	6.5	4.79	8.6	6.34	11	8.11
	12.9	7.6	5.61	10	7.37	12.9	9.51
M6	8.8	7.7	5.67	10.1	7.44	13	9.59
	10.9	11.3	8.33	14.9	10.98	19.1	14.09
	12.9	13.2	9.73	17.4	12.83	22.3	16.45
M7	8.8	12.6	9.29	16.8	12.39	21.8	16.08
	10.9	18.5	13.64	24.7	18.21	32	23.6
	12.9	21.6	15.93	28.9	21.31	37.5	27.66
M8	8.8	18.5	13.64	24.6	18.14	31.7	23.38
	10.9	27.2	20.06	36.1	26.62	46.4	34.22
	12.9	31.8	23.45	42.2	31.12	54.4	40.12
M10	8.8	36	26.55	48	35.4	62.8	46.32
	10.9	53	39.09	71	52.36	92.3	68.08

Sample manual. Download All 1002 pages at:

<https://www.arepairmanual.com/downloads/abg5820-volvo-tracked-pavers-service-manual/>

M12	12.9	62	45.72	83	61.21	107	78.92
	8.8	63	46.46	84	61.95	108	79.66
	10.9	92	67.85	123	90.72	158.8	117.12
	12.9	108	79.65	144	106.20	185.5	136.82
M14	8.8	100	73.75	133	98.09	172.6	127.3
	10.9	146	107.68	195	143.82	252.9	186.53
	12.9	171	126.12	229	168.90	296.3	218.54
M16	8.8	153	112.84	206	151.93	268.6	198.11
	10.9	224	165.21	302	222.74	395.1	291.41
	12.9	262	193.24	354	261.09	462.5	341.12
M18	8.8	220	162.26	295	217.58	383.1	282.56
	10.9	314	231.59	421	310.51	546.5	403.08
	12.9	367	270.68	492	362.88	638.8	471.15
M20	8.8	308	227.16	415	306.08	542.8	400.35
	10.9	438	323.05	592	436.63	773.5	570.5
	12.9	513	378.36	692	510.39	904.6	667.2
M22	8.8	417	307.56	567	418.19	745.8	550.07
	10.9	595	438.84	807	595.21	1062.5	783.66
	12.9	696	513.34	945	696.99	1243.4	917.08
M24	8.8	529	390.17	714	526.61	933.2	688.29
	10.9	754	556.12	1017	750.1	1329.2	980.37
	12.9	882	650.52	1190	877.69	1555.4	1147.2
M27	8.8	772	569.39	1050	774.44	1382.8	1019.9
	10.9	1100	811.31	1496	1103.39	1969.8	1452.85
	12.9	1287	949.24	1750	1290.73	2304.9	1700
M30	8.8	1053	776.65	1428	1053.23	2090.8	1542.09
	10.9	1500	1106.34	2033	1499.46	2670.5	1969.66
	12.9	1755	1294.42	2380	1755.39	3125.5	2305.25

UNC threads, coarse pitch	Nm	lbf ft
1/4"	9 ±2	6.6 ±1.5
5/16"	18 ±4	13 ±3.0
3/8"	33 ±8	24 ±5.9
7/16"	54 ±14	40 ±10
1/2"	80 ±20	59 ±15
9/16"	120 ±30	89 ±22
5/8"	170 ±40	130 ±30
3/4"	300 ±70	220 ±52
7/8"	485 ±115	360 ±85
1"	725 ±175	530 ±130

Document Title: Component locations	Function Group: 030	Information Type: Service Information	Date: 4/29/2026
Profile: ABG5820 Volvo PID:80690332			

Component locations

Showing Selected Profile

Valid for serial numbers			
Model	Production site	Serial number start	Serial number stop
ABG5820 Volvo PID:80690332			

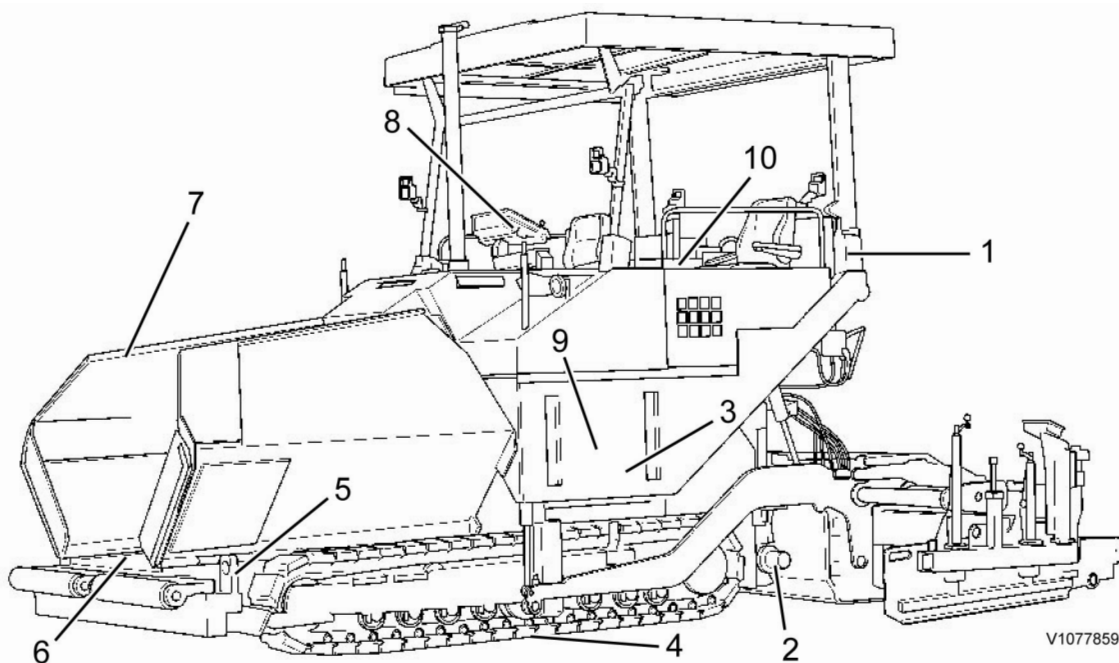

V1077859

Figure 1
Machine view

Position	Description
1	Superstructure
2	Auger
3	Hydraulic
4	Propulsion System
5	Frame
6	Conveyors
7	Hopper
8	Control panel
9	Drive
10	Electrics

Document Title: Instruments and controls, overview	Function Group: 030	Information Type: Service Information	Date: 4/29/2026
Profile: ABG5820 Volvo PID:80690332			

[Go back to Index Page](#)

Instruments and operating controls, specifications

Showing Selected Profile

Valid for serial numbers			
Model	Production site	Serial number start	Serial number stop
ABG5820 Volvo PID:80690332			

Main control unit	
Function	Operate the machine yourself Indication, monitoring, data acquisition
Weight	12 kg (26 lb)
16 Keys	Menu navigation, input, figure pad
61 Keys	Direct machine operation
8 Keys	Menu-dependent alternating functions
27 LEDs status display	26 x green 1 x orange
6 LEDs error message display	red
Back lighting	LED, 24 V DC, adjustable light intensity
Test for keypad and LED status	via operating menu
Processor	Power PC
Clock frequency processor	266 MHz
Accumulator	64 MB RAM, 32 MByte Flash
Interfaces	1 x CAN 1 x Service
Operating voltage	15 - 30 V
Software	Linux-based
Display	TFT LCD, transfective
Dimension	26.4 cm (10.4 in)
Resolution	VGA 640 x 480 Pixel
Back lighting	LED-strip 2-sided
Light intensity	0 - 550 cd/m ² adjustable
Interface	CMOS-RGB

Document Title: Instruments and controls, overview	Function Group: 030	Information Type: Service Information	Date: 4/29/2026
Profile: ABG5820 Volvo PID:80690332			

[Go back to Index Page](#)

Instruments and operating controls, specifications

Showing Selected Profile

Valid for serial numbers			
Model	Production site	Serial number start	Serial number stop
ABG5820 Volvo PID:80690332			

Screed control unit	
Number of external control panels per machine	2
Function	Operate the machine yourself Optical feedback of switch states via LED Display of machine data
Weight	3.2 kg (7.1 lbs)
4 keys	Menu navigation, input
15 keys	Direct machine operation
4 LEDs status display	3 x green 1 x green/red
Back lighting	LED, 24 V DC, non-adjustable light intensity
Interfaces	1 x CAN
Operating voltage	24 V
Software	proprietary
Display	two-line monochrome background lit

Document Title: Instruments and controls, overview	Function Group: 030	Information Type: Service Information	Date: 4/29/2026
Profile: ABG5820 Volvo PID:80690332			

[Go back to Index Page](#)

Instruments and operating controls, specifications

Showing Selected Profile

Valid for serial numbers			
Model	Production site	Serial number start	Serial number stop
ABG5820 Volvo PID:80690332			

Auxiliary control panel	
Function	Loading of machine onto transport vehicle Emergency operation together with external control panels if the control desk has failed
Weight	2.1 kg (4.6 lbs)
4 switches	Direct machine operation
2 potentiometer	Direct machine operation
Feed cable	2 m (6.6 ft.) firmly connected with housing
Housing	Stainless steel
Interfaces	analog and digital 17 pin connector
Operating voltage	15 - 30 V

Document Title: Instruments and controls, overview	Function Group: 030	Information Type: Service Information	Date: 4/29/2026
Profile: ABG5820 Volvo PID:80690332			

[Go back to Index Page](#)

Instruments and operating controls, specifications

Showing Selected Profile

Valid for serial numbers			
Model	Production site	Serial number start	Serial number stop
ABG5820 Volvo PID:80690332			

Emergency stop button	
Switch module version	Normally closed
Switch module number	2
Protective functions	ISO 13850 EN 418 Forced opening to IEC/EN 60947-5-1
Weight	0.2 kg (0.44 lbs)

Document Title: Instruments and controls, overview	Function Group: 030	Information Type: Service Information	Date: 4/29/2026
Profile: ABG5820 Volvo PID:80690332			

[Go back to Index Page](#)

Instruments and operating controls, specifications

Showing Selected Profile

Valid for serial numbers			
Model	Production site	Serial number start	Serial number stop
ABG5820 Volvo PID:80690332			

ThermoControl STC1600	
Measurement range	0–250°C ± 2°C
Temperature control range	30–180°C Hysteresis: -2°C
inputs	4 connections for PT100 sensors
Outputs	4 channels, each 1x blower and 1x burner max 0.5 A permanent per channel short-circuit resistant
Operating voltage	11 - 30 V DC
Temperature	Operation: +5 °C — +60 °C (+40 °F — +140 °F) Storage: -20°C — +70°C (-4 °F — +160 °F)
Humidity	max 95% relative humidity, non-condensing
Ground	Switch cabinet: 130 mm x 105 mm x 75 mm (5 in x 4 in x 3 in)
Weight	Switch cabinet: 950 g (2.1 lb)

Document Title: Conversion tables	Function Group: 030	Information Type: Service Information	Date: 4/29/2026
Profile: ABG5820 Volvo PID:80690332			

Conversion tables

Showing Selected Profile

Valid for serial numbers			
Model	Production site	Serial number start	Serial number stop
ABG5820 Volvo PID:80690332			

Length

Unit	cm	m	km	in	ft	yd	mile
cm	1	0.01	0.00001	0.3937	0.03281	0.01094	0.000006
m	100	1	0.001	39.37	3.2808	1.0936	0.00062
km	100000	1000	1	39370.7	3280.8	1093.6	0.62137
in	2.54	0.0254	0.000025	1	0.08333	0.02777	0.000015
ft	30.48	0.3048	0.000304	12	1	0.3333	0.000189
yd	91.44	0.9144	0.000914	36	3	1	0.000568
mile	160930	1609.3	1.6093	63360	5280	1760	1

1 mm = 0.1 cm - 1 mm = 0.001 m

Area

Unit	cm ²	m ²	km ²	a	ft ²	yd ²	in ²
cm ²	1	0.0001	-	0.000001	0.001076	0.000012	0.155000
m ²	10000	1	0.000001	0.01	10.764	1.1958	1550.000
km ²	-	1000000	1	10000	1076400	1195800	-
a	0.01	100	0.0001	1	1076.4	119.58	-
ft ²	-	0.092903	-	0.000929	1	0.1111	144.000
yd ²	-	0.83613	-	0.008361	9	1	1296.00
in ²	6.4516	0.000645	-	-	0.006943	0.000771	1

1 ha = 100 a - 1 mile² = 259 ha = 2.59 km²

Volume

Unit	cm ³ = cc	m ³	l	in ³	ft ³	yd ³
cm ³ = ml	1	0.000001	0.001	0.061024	0.000035	0.000001
m ³	1000000	1	1000	61024	35.315	1.30796
dm ³ (l)	1000	0.001	1	61.024	0.035315	0.001308
in ³	16.387	0.000016	0.01638	1	0.000578	0.000021
ft ³	28316.8	0.028317	28.317	1728	1	0.03704
yd ³	764529.8	0.76453	764.53	46656	27	1

1 gal (US) = 3785.41 cm³ = 231 in³ = 0.83267 gal (UK)

Weight

Unit	g	kg	t	oz	lb
g	1	0.001	0.000001	0.03527	0.0022
kg	1000	1	0.001	35.273	2.20459
t	1000000	1000	1	35273	2204.59
oz	28.3495	0.02835	0.000028	1	0.0625
lb	453.592	0.45359	0.000454	16	1

1 ton (metric) = 1.1023 ton (US) = 0.9842 ton (UK)

Pressure

Unit	kp/cm ²	bar	Pa=N/m ²	kPa	lbf/in ²	lbf/ft ²
kp/cm ²	1	0.98067	98066.5	98.0665	14.2233	2048.16
bar	1.01972	1	100000	100	14.5037	2088.6
Pa=N/m ²	0.00001	0.001	1	0.001	0.00015	0.02086
kPa	0.01020	0.01	1000	1	0.14504	20.886
lbf/in ²	0.07032	0.0689	6894.76	6.89476	1	144
lbf/ft ²	0.00047	0.00047	47.88028	0.04788	0.00694	1

kg/cm² = 735.56 Dry (mmHg) = 0.96784 atm

Unit explanations

Unit	abbreviation
Newton meter	Nm
Kilopoundmeter	kpm
Kilopascal	kPa
Megapascal	MPa
Kilowatt	kW
kilojoule	kJ
British thermal unit	Btu
Calorie	cal

Approx. conversion

SI unit	Conversion factor	Non SI	Conversion factor	SI
Torque				
Nm	x10.2	=kg/cm	x0.8664	=lb in
Nm	x0.74	=lbf-ft	x1.36	=Nm
Nm	x0.102	=kg/m	x7.22	=lbft
Pressure (Pa = N/m²)				
kPa	x4.0	=in.H ₂ O	x0.249	=kPa
kPa	x0.30	=in.Hg	x3.38	=kPa
kPa	x0.145	=psi	x6.89	=kPa
bar	x14.5	=psi	x0.069	=bar
kp/cm ²	x14.22	=psi	x0.070	=kp/cm ²
N/mm ²	x145.04	=psi	x0.069	=bar
MPa	x145	=psi	x0.00689	=MPa
Power (W = J/s)				
kW	x1.36	=hp(cv)	x0.736	=kW

kW	x1.34	= bhp	x0.746	= kW
kW	x0.948	= Btu/s	x1.055	= kW
W	x0.74	= ft-lb/s	x1.36	= W
Energy (J = Nm)				
kJ	x0.948	= Btu	x1.055	= kJ
J	x0.239	= calorie	x4.19	= J
Speed and acceleration				
m/s ²	x3.28	= ft/s ²	x0.305	= m/s ²
m/s	x3.28	= ft/s	x0.305	= m/s
km/h	x0.62	= mph	x1.61	= km/h
Horsepower/torque				
Bhp x5252 rpm = TQ (lb-ft)			TQ x rpm 5252 = bhp	
Temperature				
$^{\circ}\text{C} = (^{\circ}\text{F} - 32) / 1.8$			$^{\circ}\text{F} = (^{\circ}\text{C} \times 1.8) + 32$	
Flow factor				
l/min (dm ³ /min)	x0.264	= US gal/min	x3.785	= liter/min

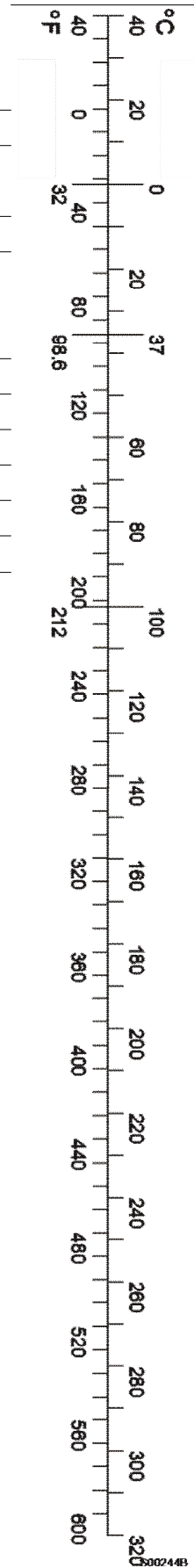

Document Title: Transporting the machine	Function Group: 050	Information Type: Service Information	Date: 4/29/2026
Profile: ABG5820 Volvo PID:80690332			

Machine, transporting

Showing Selected Profile

Valid for serial numbers			
Model	Production site	Serial number start	Serial number stop
ABG5820 Volvo PID:80690332			

WARNING

If the machine is to be driven from a loading dock onto the platform of a truck trailer or railway car, make sure that the vehicle is securely braked, for example, wheels blocked. Make sure that there is no risk that the vehicle cannot roll over or sway in a dangerous manner when the machine is driven on.

- Raise auger to top position.
- Move the screed into the transport position and lock it in the transport attachment.
- Drive machine onto transport vehicle.

NOTE!

Drive straight onto the transport vehicle so that the machine cannot slip sideways from the ramp.

- Lower screed onto transport vehicle.
- Turn off the engine.
- Remove main control panel and external control panels and store securely.
- Flap down the all-weather roof.
- Withdraw battery isolation switch.
- Lash machine securely to transport vehicle.

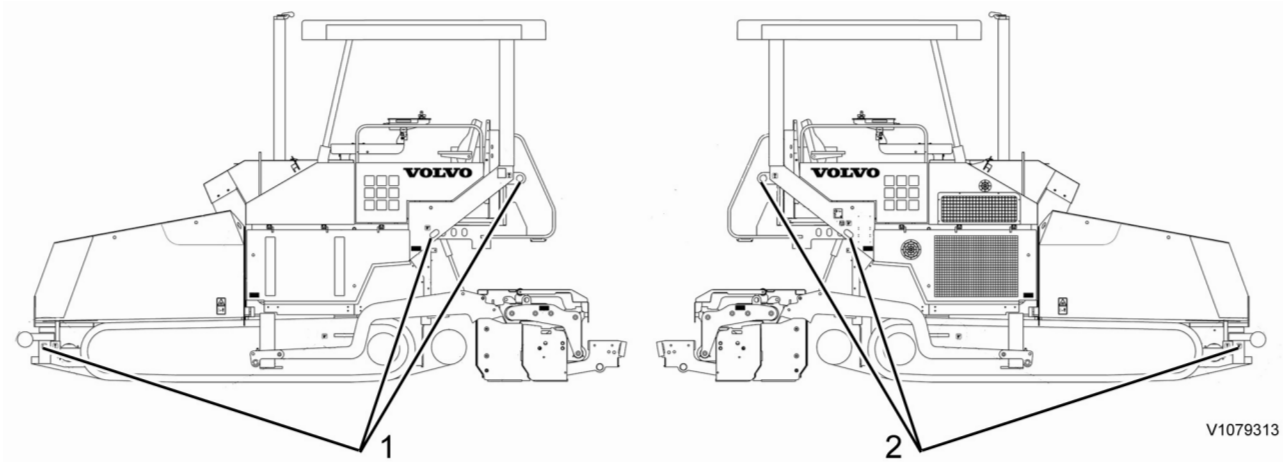

V1079313

Figure 1
Lashing points

Position	Description
1	Machine lashing points, left (LH)
2	Machine lashing points, right (RH)

Secure (lash) the machine to the loading platform of the transport vehicle so it cannot tip over or roll away.



Marker plate for lashing

Lifting of machine

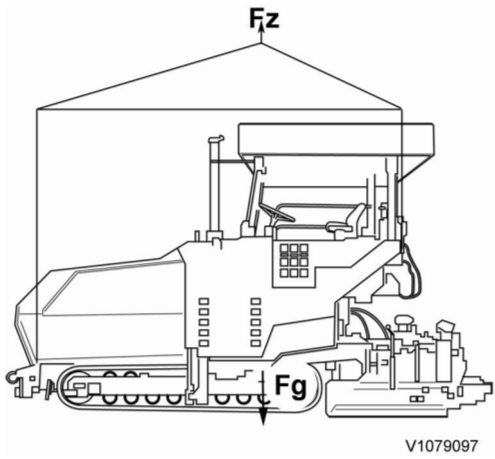

V1079097

Figure 2

Lifting of machine

Position	Descriptions
Fg	Centre of gravity
Fz	Tractive power

To raise the machine, use the stop points provided. Stop points: see picture.



Marking plate - Load/lift

Document Title: Operation numbers for additional work	Function Group: 070	Information Type: Service Information	Date: 4/29/2026
Profile: Tracked Pavers (PAT)			

Operation numbers for additional work

Showing Selected Profile

These operations can be used to identify work that is not included in the time guide or described in the methods in the Service Manual. When these operations are used, a description of the work that has been performed must be provided.

Other work related to engine

Op. no. 070-210

This operation can be used when work has been done related to the engine and function group 2 when no applicable method description was available. When this operation is used, additional information is required:

- Description of work that has been done

Other work related to electrical system

Op. no. 070-310

This operation can be used when work has been done related to the electrical system and function group 3 when no applicable method description was available. When this operation is used, additional information is required:

- Description of work that has been done

Other work related to transmission, gearbox, travel motor, swing motor

Op. no. 070-410

This operation can be used when work has been done related to the transmission, gearbox, travel motor or swing motor and function group 4 when no applicable method description was available. When this operation is used, additional information is required:

- Description of work that has been done

Other work related to drive axle

Op. no. 070-470

This operation can be used when work has been done related to the drive axle and function group 46 when no applicable method description was available. When this operation is used, additional information is required:

- Description of required work that have been done

Other work related to brake system

Op. no. 070-510

This operation can be used when work has been done related to the brake system and function group 5 when no applicable

method description was available. When this operation is used, additional information is required:

- Description of work that has been done

Other work related to steering system

Op. no. 070-610

This operation can be used when work has been done related to the steering system and function group 6 when no applicable method description was available. When this operation is used, additional information is required:

- Description of work that has been done

Other work related to frame link, axle suspension

Op. no. 070-710

This operation can be used when work has been done related to the frame link, axle suspension and other parts related to function group 7 when no applicable method description was available. When this operation is used, additional information is required:

- Description of work that has been done

Other work related to cab, air conditioning

Op. no. 070-810

This operation can be used when work has been done related to the cab, air conditioning and other parts related to function group 8 when no applicable method description was available. When this operation is used, additional information is required:

- Description of work that has been done

Other work related to hydraulic system

Op. no. 070-910

This operation can be used when work has been done related to the hydraulic system and other parts related to function group 9 when no applicable method description was available. When this operation is used, additional information is required:

- Description of work that has been done

Document Title: E-7006	Function Group: 080	Information Type: Service Information	Date: 4/29/2026
Profile: ABG5820 Volvo PID:80690332			

E-7006

Showing Selected Profile

Valid for serial numbers			
Model	Production site	Serial number start	Serial number stop
ABG5820 Volvo PID:80690332			

All dimensions in mm.

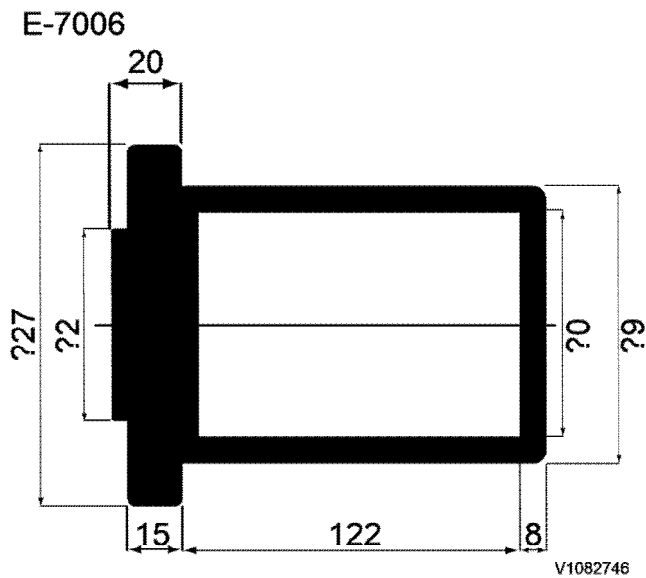

Figure 1

E-7006 Drift

Material: S355 JR or better.

Document Title: E-7008	Function Group: 080	Information Type: Service Information	Date: 4/29/2026
Profile: ABG5820 Volvo PID:80690332			

E-7008

Showing Selected Profile

Valid for serial numbers			
Model	Production site	Serial number start	Serial number stop
ABG5820 Volvo PID:80690332			

All dimensions in mm.

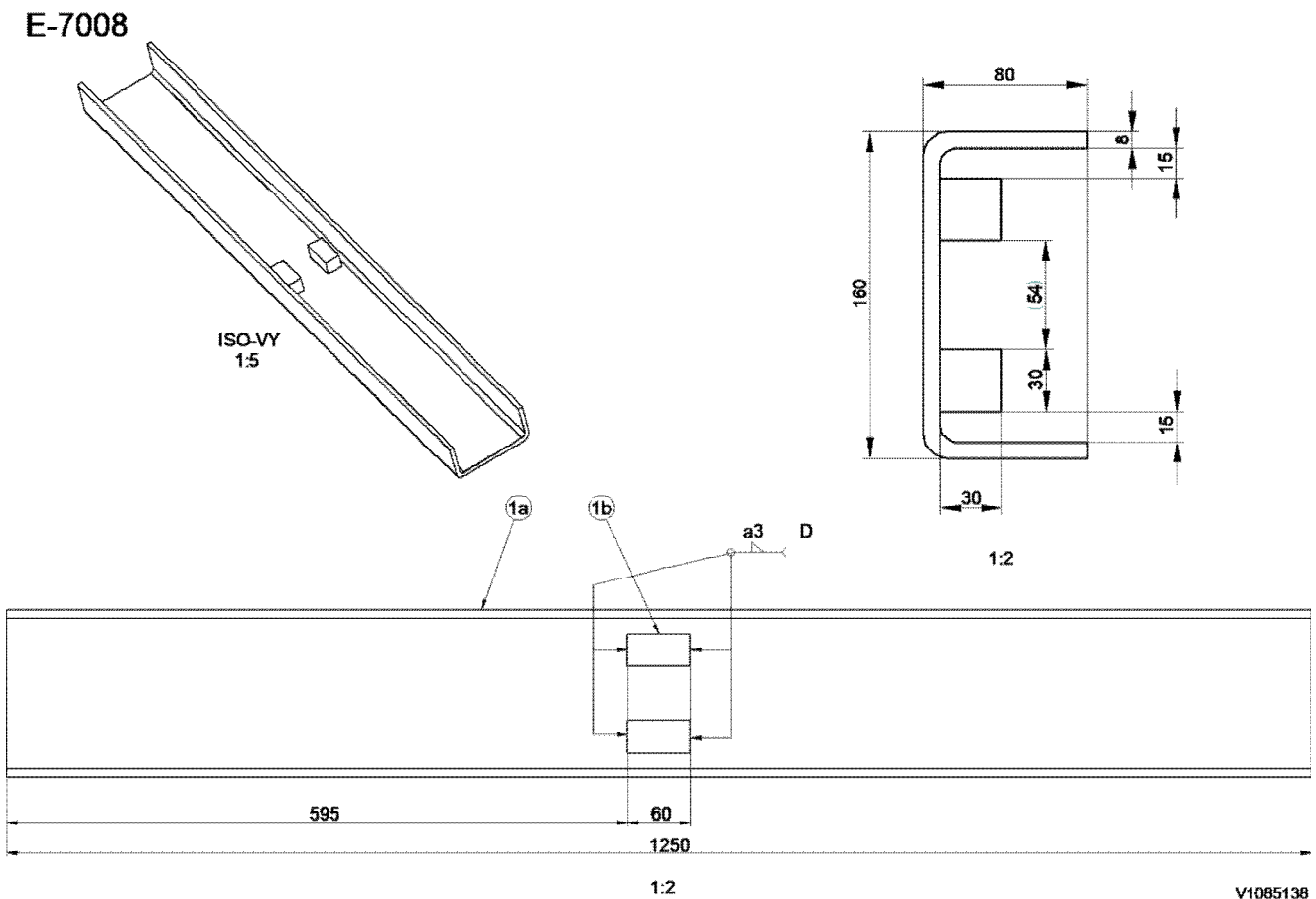

V1085138

Figure 1

E-7008 U bar

Material: S355 JR or better.

Document Title: E-7009	Function Group: 080	Information Type: Service Information	Date: 4/29/2026
Profile: ABG5820 Volvo PID:80690332			

E-7009

Showing Selected Profile

Valid for serial numbers			
Model	Production site	Serial number start	Serial number stop
ABG5820 Volvo PID:80690332			

All dimensions in mm.

E-7009

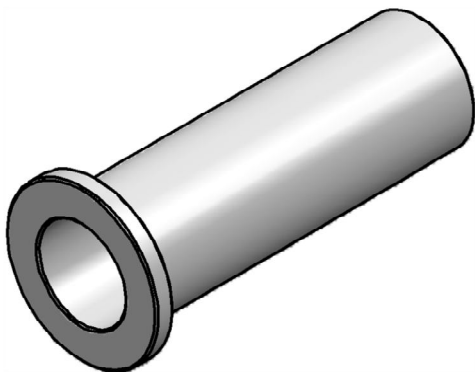
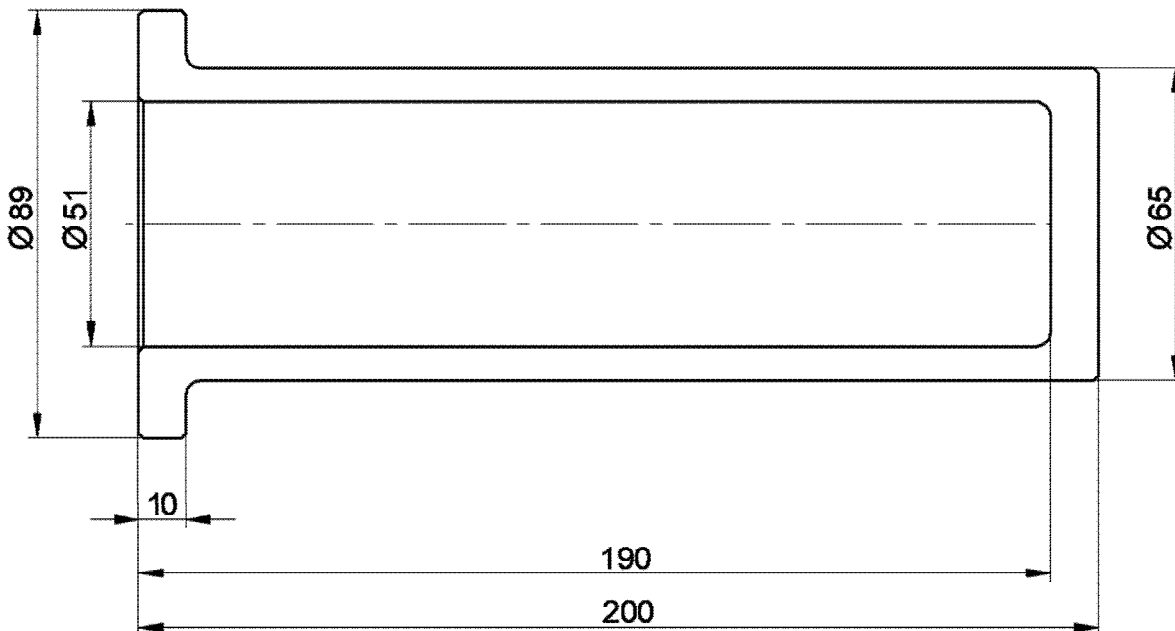

V1086432

Figure 1

E-7009 Drift

Material: S355 JR or better.

Document Title: Lubricants, service capacities and intervals	Function Group: 160	Information Type: Service Information	Date: 4/29/2026
Profile: ABG5820 Volvo PID:80690332			

[Go back to Index Page](#)

Lubricants, service capacities and intervals

Showing Selected Profile

Valid for serial numbers			
Model	Production site	Serial number start	Serial number stop
ABG5820 Volvo PID:80690332	Hameln	51	701260

Description	Used for	Quantity	Specification	VOLVO Part no.	Change intervals
Engine oil	Engine	11 litres	SAE 10W-40 ACEA E6 / E7	11988175	every 500 hours
Hydraulic oil	Hydraulic system	130 litres	HVLP 100; DIN 51524-3	RM80635402	every 1000 hours
Transmission oil	Travel gearbox	4 litres	Shell Spirax MB90 Do not use limited slip (LS) transmission oil!	RM13923131	Warranty inspection, first 100 operating hours every 1000 hours
	Pump distributor gear	1.5 litres			
Grease	Auger bearings Conveyor bearings remaining grease points	as required	Volvo high temperature grease	RM80795826	-
Fuel	Engine (fuel tank)	300 litres	CEN EN 590 DIN 51601 BS 2869: A1; A2 ASTM D975-88: 1-D, 2-D NATO Code: F54. F-75	-	-
Coolant	Engine (radiator)	20 litres	BASF Glysantin G48 Antifreeze protection to -35 °C NOTE! Do not mix coolants! Use Volvo Coolant VCS only for complete fresh fill.	RM56246853	every 4000 hours

Document Title: Lubricants, service capacities and intervals	Function Group: 160	Information Type: Service Information	Date: 4/29/2026
Profile: ABG5820 Volvo PID:80690332			

[Go back to Index Page](#)

Lubricants, service capacities and intervals

Showing Selected Profile

Valid for serial numbers			
Model	Production site	Serial number start	Serial number stop
ABG5820 Volvo PID:80690332	Hameln	701261	701910

Description	Used for	Quantity	Specification	VOLVO Part no.	Change intervals
Engine oil	Engine	11 litres	SAE 10W-40 ACEA E6 / E7	11988175	every 500 hours
Hydraulic oil	Hydraulic system	130 litres	HVLP 100; DIN 51524-3	RM80635402	every 1000 hours
Transmission oil	Travel gearbox	4 litres	Shell Spirax MB90 Do not use limited slip (LS) transmission oil!	RM13923131	Warranty inspection, first 100 operating hours every 1000 hours
	Pump distributor gear	1.5 litres			
Grease	Auger bearings Conveyor bearings remaining grease points	as required	Volvo high temperature grease	RM80795826	-
Fuel	Engine (fuel tank)	300 litres	CEN EN 590 DIN 51601 BS 2869: A1; A2 ASTM D975-88: 1-D, 2-D NATO Code: F54. F-75	-	-
Coolant	Engine (radiator)	20 litres	BASF Glysantin G48 Antifreeze protection to -35 °C NOTE! Do not mix coolants! Use Volvo Coolant VCS only for complete fresh fill.	RM56246853	every 2000 hours

Document Title: Lubricants, service capacities and intervals	Function Group: 160	Information Type: Service Information	Date: 4/29/2026
Profile: ABG5820 Volvo PID:80690332			

[Go back to Index Page](#)

Lubricants, service capacities and intervals

Showing Selected Profile

Valid for serial numbers			
Model	Production site	Serial number start	Serial number stop
ABG5820 Volvo PID:80690332	Hameln	701911	702083

All quantity data are approximate and may vary according to machine, even within the same series. After changing or topping up operating fluids, check fill levels and correct where necessary.

Special requirements apply to the conversion to biodegradable hydraulic oil.

Please contact your dealer if you have any questions or would like further information on oils, lubricants and extreme exterior temperatures.

Engine oil

Used for	Oil grade	Change intervals (Sulphur content in the fuel)			Quantity
		0 - 3000 ppm	3000 - 5000 ppm	5000 - 10000 ppm	
Engine	Volvo Ultra Diesel Engine Oil VDS-3	every 500 hours	every 250 hours	every 125 hours	11 litres (671.3 in ³)
	Volvo Super Diesel Engine Oil VDS-2				
	ACEA: E9 API: CJ-4	every 250 hours	every 125 hours	every 75 hours	
	VDS-2 plus ACEA-E7 VDS-2 plus API CI-4 or CH-4				

Recommended viscosities at varying ambient temperatures	° C										
	-30	-20	-10	0	+10	+20	+30	+40	+50	+60	
	° F										
	-22	-4	+14	+32	+50	+68	+86	+104	+122	+140	
				SAE 15W-40							
				SAE 10W-40							
			SAE 5W-30								
			SAE 5W-40								
				SAE 30							
				SAE 40							

V1140503

Figure 1

Observe the recommended service intervals for the oil grade and sulphur content in the fuel.

Hydraulic oil

Used for	Oil grade	Change intervals	Quantity
Hydraulic system	Volvo Super Hydraulic Oil ISO VG 100 (HVL100)	every 1000 hours	130 litres (7,933 in ³)
	Volvo Biodegradable Hydraulic Oil 68		

Recommended viscosities at varying ambient temperatures	°C	-30	-20	-10	0	+10	+20	+30	+40	+50	+60	
	°F	-22	-4	+14	+32	+50	+68	+86	+104	+122	+140	
					Volvo Super Hydraulic Oil ISO VG100							
					Volvo Biodegradable Hydraulic Oil 68							

V1140450

Figure 2

Transmission oil

Used for	Oil grade	Change intervals	Quantity
Travel gearbox	Volvo Super Transmission Oil SAE 80W-90	Warranty inspection, first 100 operating hours every 1000 hours	4 litres (244 in ³)
Pump distributor gear			1.5 litres (91.5 in ³)

Recommended viscosity at varying ambient temperatures	°C	-30	-20	-10	0	+10	+20	+30	+40	+50	+60	
	°F	-22	-4	+14	+32	+50	+68	+86	+104	+122	+140	
					Volvo Super Transmission Oil SAE 80W-90							

V1140451

Figure 3

Coolant

Used for	Quality	Change intervals	Quantity
Engine (radiator)	Volvo Coolant VCS	every 4000 hours	20 litres (1220.5 in ³)

Recommended mixing ratios at varying ambient temperatures

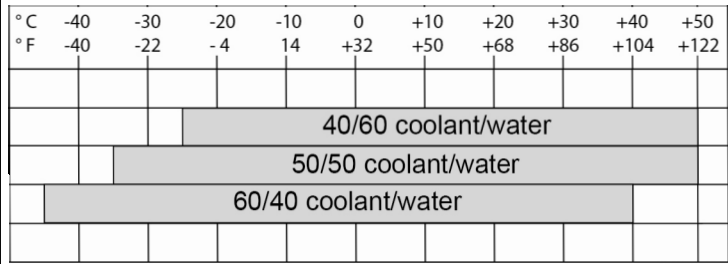

V1135082

Figure 4

All-weather roof

Used for	Viscosity	Change interval	Quantity
All-weather roof pump	SAE 15W-40	every 3000 hours	0.25 litres (15 in ³)

Grease

Used for	Quality	Change interval	Quantity
Auger bearings	Volvo high temperature grease	—	As required
Conveyor bearings			
Remaining grease points			

Fuel

Used for	Quality	Change interval	Quantity
Engine (fuel tank)	DIN EN 590 DIN 51601 BS2869: A1, A2 ASTM D975-88: 1-D, 2-D NATO Code F-54, F-75	—	300 litres (18,307.1 in ³)

Document Title: Lubricants, service capacities and intervals	Function Group: 160	Information Type: Service Information	Date: 4/29/2026
Profile: ABG5820 Volvo PID:80690332			

[Go back to Index Page](#)

Lubricants, service capacities and intervals

Showing Selected Profile

Valid for serial numbers			
Model	Production site	Serial number start	Serial number stop
ABG5820 Volvo PID:80690332	Hameln	702084	702731

All quantity data are approximate and may vary according to machine, even within the same series. After changing or topping up operating fluids, check fill levels and correct where necessary.

Special requirements apply to the conversion to biodegradable hydraulic oil.

Please contact your dealer if you have any questions or would like further information on oils, lubricants and extreme exterior temperatures.

Engine oil

Used for	Oil grade	Change intervals (Sulphur content in the fuel)			Quantity
		0 - 3000 ppm	3000 - 5000 ppm	5000 - 10000 ppm	
Engine	Volvo Ultra Diesel Engine Oil VDS-3	every 500 hours	every 250 hours	every 125 hours	11 litres (671.3 in ³)
	Volvo Super Diesel Engine Oil VDS-2				
	ACEA: E9 API: CJ-4	every 250 hours	every 125 hours	every 75 hours	
	VDS-2 plus ACEA-E7 VDS-2 plus API CI-4 or CH-4				

Recommended viscosities at varying ambient temperatures	° C	-30	-20	-10	0	+10	+20	+30	+40	+50	+60	
	° F	-22	-4	+14	+32	+50	+68	+86	+104	+122	+140	
				SAE 15W-40								
				SAE 10W-40								
			SAE 5W-30									
			SAE 5W-40									
				SAE 30								
					SAE 40							

V1140503

Figure 1

Recommended mixing ratios at varying ambient temperatures

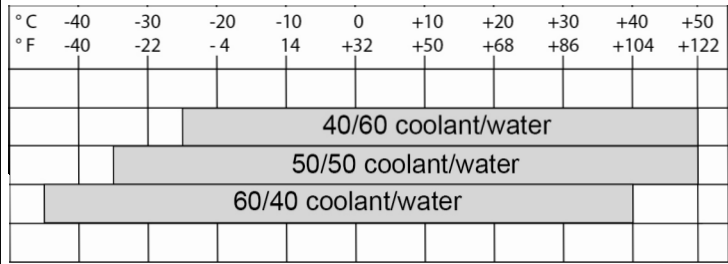

Figure 4

All-weather roof

Used for	Viscosity	Change interval	Quantity
All-weather roof pump	SAE 15W-40	every 3000 hours	0.25 litres (15 in ³)

Grease

Used for	Quality	Change interval	Quantity
Auger bearings	Volvo high temperature grease	—	As required
Conveyor bearings			
Remaining grease points			

Fuel

Used for	Quality	Change interval	Quantity
Engine (fuel tank)	DIN EN 590 DIN 51601 BS2869: A1, A2 ASTM D975-88: 1-D, 2-D NATO Code F-54, F-75	—	240 litres (14,645.7 in ³)

Document Title: Lubricants, service capacities and intervals	Function Group: 160	Information Type: Service Information	Date: 4/29/2026
Profile: ABG5820 Volvo PID:80690332			

[Go back to Index Page](#)

Lubricants, service capacities and intervals

Showing Selected Profile

Valid for serial numbers			
Model	Production site	Serial number start	Serial number stop
ABG5820 Volvo PID:80690332	Hameln	702732	709999

All quantity data are approximate and may vary according to machine, even within the same series. After changing or topping up operating fluids, check fill levels and correct where necessary.

Special requirements apply to the conversion to biodegradable hydraulic oil.

Please contact your dealer if you have any questions or would like further information on oils, lubricants and extreme exterior temperatures.

Engine oil

Used for	Oil grade	Change intervals (Sulphur content in the fuel)			Quantity
		0–3000 ppm	3000–5000 ppm	5000–10000 ppm	
Engine	Volvo Ultra Diesel Engine Oil VDS-3	every 500 hours	every 250 hours	Every 125 hours	11 litres (671.3 in ³)
	Volvo Super Diesel Engine Oil VDS-2				
	ACEA: E9 API: CJ-4	every 250 hours	every 125 hours	every 75 hours	
	VDS-2 <i>plus</i> ACEA-E7 VDS-2 <i>plus</i> API CI-4 or CH-4				

Recommended viscosities at varying ambient temperatures

° C	-30	-20	-10	0	+10	+20	+30	+40	+50	+60
° F	-22	- 4	+14	+32	+50	+68	+86	+104	+122	+140
				SAE 15W-40						
			SAE 10W-40							
		SAE 5W-30								
	SAE 5W-40									
			SAE 30							
				SAE 40						

V1140503

Figure 1

Observe the recommended service intervals for the oil grade and sulphur content in the fuel.

Hydraulic oil

Used for	Oil grade	Change intervals	Quantity
Hydraulic system	Volvo Super Hydraulic Oil ISO VG 100 (HVL100)	Every 1000 hours	130 litres (7,933 in ³)
	Volvo Biodegradable Hydraulic Oil 68		

Recommended viscosities at varying ambient temperatures	° C	-30	-20	-10	0	+10	+20	+30	+40	+50	+60	
	° F	-22	- 4	+14	+32	+50	+68	+86	+104	+122	+140	
					Volvo Super Hydraulic Oil ISO VG100							
					Volvo Biodegradable Hydraulic Oil 68							

V1140450

Figure 2

Transmission oil

Used for	Oil grade	Change intervals	Quantity
Travel gearbox	Volvo Super Transmission Oil SAE 80W-90	Warranty inspection, first 100 operating hours	4.4 litres (268 in ³)
Pump distributor gear		Every 1000 hours	1.5 litres (91.5 in ³)

Recommended viscosity at varying ambient temperatures	° C	-30	-20	-10	0	+10	+20	+30	+40	+50	+60	
	° F	-22	- 4	+14	+32	+50	+68	+86	+104	+122	+140	
					Volvo Super Transmission Oil SAE 80W-90							

V1140451

Figure 3

Coolant

Used for	Quality	Change intervals	Quantity
Engine (radiator)	Volvo Coolant VCS	Every 4000 hours	20 litres (1,220.5 in ³)

Recommended mixing ratios at varying ambient temperatures

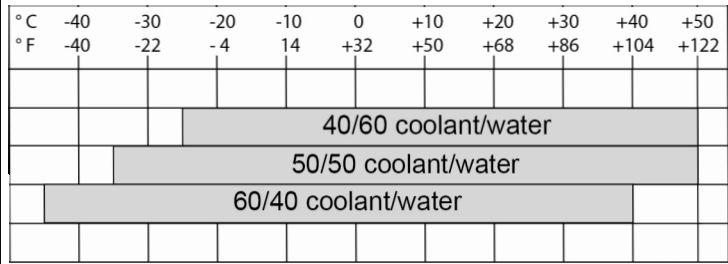

V1135082

Figure 4

All-weather roof

Used for	Viscosity	Change interval	Quantity
All-weather roof pump	SAE 15W-40	Every 3000 hours	0.25 litres (15 in³)

Grease

Used for	Quality	Change interval	Quantity
Auger bearings	Volvo High Temperature Grease	—	As required
Conveyor bearings			
Remaining grease points			

Fuel

Used for	Quality	Change interval	Quantity
Engine (fuel tank)	DIN EN 590 DIN 51601 BS2869: A1, A2 ASTM D975-88: 1-D, 2-D NATO Code F-54, F-75	—	240 litres (14,645.7 in³)