

Document Title: Standard tightening torques	Function Group: 030	Information Type: Service Information	Date: 4/29/2026
Profile: ABG325 Volvo PID:56261480			

Standard tightening torques

Showing Selected Profile

Valid for serial numbers			
Model	Production site	Serial number start	Serial number stop
ABG325 Volvo PID:56261480			

Tightening torques in the following tables refer to bolted joints with tensile strength according to the below. The tables should be regarded as general guidelines for tightening bolted joints where nothing else is specified.

NOTE!

Increase the values by 10% for flange bolt type U6FS. Bolts and nuts should be clean and lubricated with oil.

Surface coating		Coefficient of friction	
Non-electrolytic zinc plate coatings	ISO10683-FLZN/ZN/TL/480	0.08	
	ISO10683-FLZN/ZN/TL/720		
	(ISO10683) Geomet 500A	0.12	
Yellowish iridescent	ISO4042-A2C		
Electrolytic coating	ASTMF 1941 Fe/Zn5ANS	0.24	

Dimension s	Strength classes	Coefficient of friction					
		0.08		0.12		0.24	
		Tightening torque (Nm)	Tightening torques: (lbf ft)	Tightening torque (Nm)	Tightening torques: (lbf ft)	Tightening torque (Nm)	Tightening torques: (lbf ft)
M4	8.8	2.3	1.7	3	2.21	3.8	2.8
	10.9	3.3	2.43	4.6	3.39	5.5	4.06
	12.9	3.9	2.87	5.1	3.76	6.5	4.79
M5	8.8	4.4	3.24	5.9	4.35	7.5	5.53
	10.9	6.5	4.79	8.6	6.34	11	8.11
	12.9	7.6	5.61	10	7.37	12.9	9.51
M6	8.8	7.7	5.67	10.1	7.44	13	9.59
	10.9	11.3	8.33	14.9	10.98	19.1	14.09
	12.9	13.2	9.73	17.4	12.83	22.3	16.45
M7	8.8	12.6	9.29	16.8	12.39	21.8	16.08
	10.9	18.5	13.64	24.7	18.21	32	23.6
	12.9	21.6	15.93	28.9	21.31	37.5	27.66
M8	8.8	18.5	13.64	24.6	18.14	31.7	23.38
	10.9	27.2	20.06	36.1	26.62	46.4	34.22
	12.9	31.8	23.45	42.2	31.12	54.4	40.12
M10	8.8	36	26.55	48	35.4	62.8	46.32
	10.9	53	39.09	71	52.36	92.3	68.08

Sample manual. Download All 199 pages at:

<https://www.arepairmanual.com/downloads/abg325-volvo-tracked-pavers-service-manual/>

Product: ABG325 Volvo Tracked Pavers Service Manual

Full Download: <https://www.arepairmanual.com/downloads/abg325-volvo-tracked-pavers-service-manual/>

M12	12.9	62	45.72	83	61.21	107	78.92
	8.8	63	46.46	84	61.95	108	79.66
	10.9	92	67.85	123	90.72	158.8	117.12
M14	12.9	108	79.65	144	106.20	185.5	136.82
	8.8	100	73.75	133	98.09	172.6	127.3
	10.9	146	107.68	195	143.82	252.9	186.53
M16	12.9	171	126.12	229	168.90	296.3	218.54
	8.8	153	112.84	206	151.93	268.6	198.11
	10.9	224	165.21	302	222.74	395.1	291.41
M18	12.9	262	193.24	354	261.09	462.5	341.12
	8.8	220	162.26	295	217.58	383.1	282.56
	10.9	314	231.59	421	310.51	546.5	403.08
M20	12.9	367	270.68	492	362.88	638.8	471.15
	8.8	308	227.16	415	306.08	542.8	400.35
	10.9	438	323.05	592	436.63	773.5	570.5
M22	12.9	513	378.36	692	510.39	904.6	667.2
	8.8	417	307.56	567	418.19	745.8	550.07
	10.9	595	438.84	807	595.21	1062.5	783.66
M24	12.9	696	513.34	945	696.99	1243.4	917.08
	8.8	529	390.17	714	526.61	933.2	688.29
	10.9	754	556.12	1017	750.1	1329.2	980.37
M27	12.9	882	650.52	1190	877.69	1555.4	1147.2
	8.8	772	569.39	1050	774.44	1382.8	1019.9
	10.9	1100	811.31	1496	1103.39	1969.8	1452.85
M30	12.9	1287	949.24	1750	1290.73	2304.9	1700
	8.8	1053	776.65	1428	1053.23	2090.8	1542.09
	10.9	1500	1106.34	2033	1499.46	2670.5	1969.66
	12.9	1755	1294.42	2380	1755.39	3125.5	2305.25

UNC threads, coarse pitch	Nm	lbf ft
1/4"	9 ±2	6.6 ±1.5
5/16"	18 ±4	13 ±3.0
3/8"	33 ±8	24 ±5.9
7/16"	54 ±14	40 ±10
1/2"	80 ±20	59 ±15
9/16"	120 ±30	89 ±22
5/8"	170 ±40	130 ±30
3/4"	300 ±70	220 ±52
7/8"	485 ±115	360 ±85
1"	725 ±175	530 ±130

Sample manual. Download All 199 pages at:

<https://www.arepairmanual.com/downloads/abg325-volvo-tracked-pavers-service-manual/>

Document Title: Conversion tables	Function Group: 030	Information Type: Service Information	Date: 4/29/2026
Profile: ABG325 Volvo PID:56261480			

Conversion tables

Showing Selected Profile

Valid for serial numbers			
Model	Production site	Serial number start	Serial number stop
ABG325 Volvo PID:56261480			

Length

Unit	cm	m	km	in	ft	yd	mile
cm	1	0.01	0.00001	0.3937	0.03281	0.01094	0.000006
m	100	1	0.001	39.37	3.2808	1.0936	0.00062
km	100000	1000	1	39370.7	3280.8	1093.6	0.62137
in	2.54	0.0254	0.000025	1	0.08333	0.02777	0.000015
ft	30.48	0.3048	0.000304	12	1	0.3333	0.000189
yd	91.44	0.9144	0.000914	36	3	1	0.000568
mile	160930	1609.3	1.6093	63360	5280	1760	1

1 mm = 0.1 cm - 1 mm = 0.001 m

Area

Unit	cm ²	m ²	km ²	a	ft ²	yd ²	in ²
cm ²	1	0.0001	-	0.000001	0.001076	0.000012	0.155000
m ²	10000	1	0.000001	0.01	10.764	1.1958	1550.000
km ²	-	1000000	1	10000	1076400	1195800	-
a	0.01	100	0.0001	1	1076.4	119.58	-
ft ²	-	0.092903	-	0.000929	1	0.1111	144.000
yd ²	-	0.83613	-	0.008361	9	1	1296.00
in ²	6.4516	0.000645	-	-	0.006943	0.000771	1

1 ha = 100 a - 1 mile² = 259 ha = 2.59 km²

Volume

Unit	cm ³ = cc	m ³	l	in ³	ft ³	yd ³
cm ³ = ml	1	0.000001	0.001	0.061024	0.000035	0.000001
m ³	1000000	1	1000	61024	35.315	1.30796
dm ³ (l)	1000	0.001	1	61.024	0.035315	0.001308
in ³	16.387	0.000016	0.01638	1	0.000578	0.000021
ft ³	28316.8	0.028317	28.317	1728	1	0.03704
yd ³	764529.8	0.76453	764.53	46656	27	1

1 gal (US) = 3785.41 cm³ = 231 in³ = 0.83267 gal (UK)

Weight

Unit	g	kg	t	oz	lb
g	1	0.001	0.000001	0.03527	0.0022
kg	1000	1	0.001	35.273	2.20459
t	1000000	1000	1	35273	2204.59
oz	28.3495	0.02835	0.000028	1	0.0625
lb	453.592	0.45359	0.000454	16	1

1 ton (metric) = 1.1023 ton (US) = 0.9842 ton (UK)

Pressure

Unit	kp/cm ²	bar	Pa=N/m ²	kPa	lbf/in ²	lbf/ft ²
kp/cm ²	1	0.98067	98066.5	98.0665	14.2233	2048.16
bar	1.01972	1	100000	100	14.5037	2088.6
Pa=N/m ²	0.00001	0.001	1	0.001	0.00015	0.02086
kPa	0.01020	0.01	1000	1	0.14504	20.886
lbf/in ²	0.07032	0.0689	6894.76	6.89476	1	144
lbf/ft ²	0.00047	0.00047	47.88028	0.04788	0.00694	1

kg/cm² = 735.56 Dry (mmHg) = 0.96784 atm

Unit explanations

Unit	abbreviation
Newton meter	Nm
Kilopoundmeter	kpm
Kilopascal	kPa
Megapascal	MPa
Kilowatt	kW
kilojoule	kJ
British thermal unit	Btu
Calorie	cal

Approx. conversion

SI unit	Conversion factor	Non SI	Conversion factor	SI
Torque				
Nm	x10.2	=kg/cm	x0.8664	=lb in
Nm	x0.74	=lbf-ft	x1.36	=Nm
Nm	x0.102	=kg/m	x7.22	=lbft
Pressure (Pa = N/m²)				
kPa	x4.0	=in.H ₂ O	x0.249	=kPa
kPa	x0.30	=in.Hg	x3.38	=kPa
kPa	x0.145	=psi	x6.89	=kPa
bar	x14.5	=psi	x0.069	=bar
kp/cm ²	x14.22	=psi	x0.070	=kp/cm ²
N/mm ²	x145.04	=psi	x0.069	=bar
MPa	x145	=psi	x0.00689	=MPa
Power (W = J/s)				
kW	x1.36	=hp(cv)	x0.736	=kW

kW	x1.34	= bhp	x0.746	= kW
kW	x0.948	= Btu/s	x1.055	= kW
W	x0.74	= ft-lb/s	x1.36	= W
Energy (J = Nm)				
kJ	x0.948	= Btu	x1.055	= kJ
J	x0.239	= calorie	x4.19	= J
Speed and acceleration				
m/s ²	x3.28	= ft/s ²	x0.305	= m/s ²
m/s	x3.28	= ft/s	x0.305	= m/s
km/h	x0.62	= mph	x1.61	= km/h
Horsepower/torque				
Bhp x5252 rpm = TQ (lb-ft)			TQ x rpm 5252 = bhp	
Temperature				
$^{\circ}\text{C} = (^{\circ}\text{F} - 32) / 1.8$			$^{\circ}\text{F} = (^{\circ}\text{C} \times 1.8) + 32$	
Flow factor				
l/min (dm ³ /min)	x0.264	= US gal/min	x3.785	= liter/min

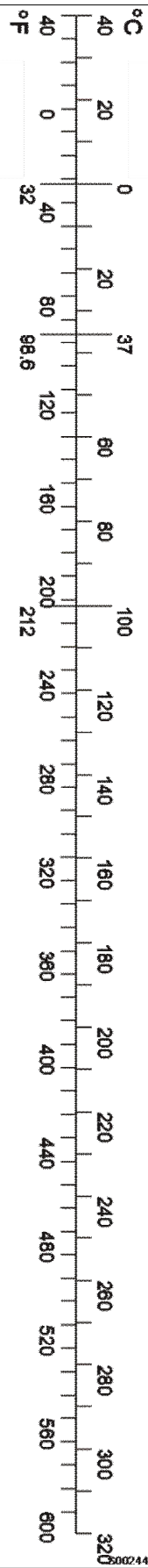

Document Title: Transporting the machine	Function Group: 050	Information Type: Service Information	Date: 4/29/2026
Profile: ABG325 Volvo PID:56261480			

Machine, transporting

Showing Selected Profile

Valid for serial numbers			
Model	Production site	Serial number start	Serial number stop
ABG325 Volvo PID:56261480			

WARNING

If the machine is to be driven from a loading dock onto the platform of a truck trailer or railway car, make sure that the vehicle is securely braked, for example, wheels blocked. Make sure that there is no risk that the vehicle cannot roll over or sway in a dangerous manner when the machine is driven on.

- Raise auger to top position.
- Move the screed into the transport position and lock it in the transport attachment.
- Drive machine onto transport vehicle.

NOTE!

Drive straight onto the transport vehicle so that the machine cannot slip sideways from the ramp.

- Lower screed onto transport vehicle.
- Turn off the engine.
- Remove main control panel and external control panels and store securely.
- Flap down the all-weather roof.
- Withdraw battery isolation switch.
- Lash machine securely to transport vehicle.

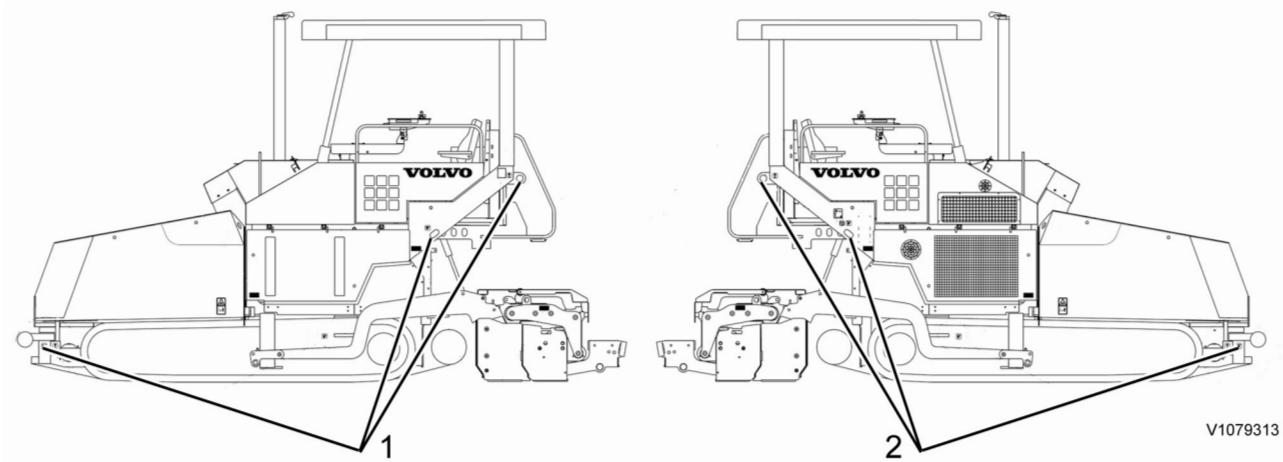

V1079313

Figure 1
Lashing points

Position	Description
1	Machine lashing points, left (LH)
2	Machine lashing points, right (RH)

Secure (lash) the machine to the loading platform of the transport vehicle so it cannot tip over or roll away.



Marker plate for lashing

Lifting of machine

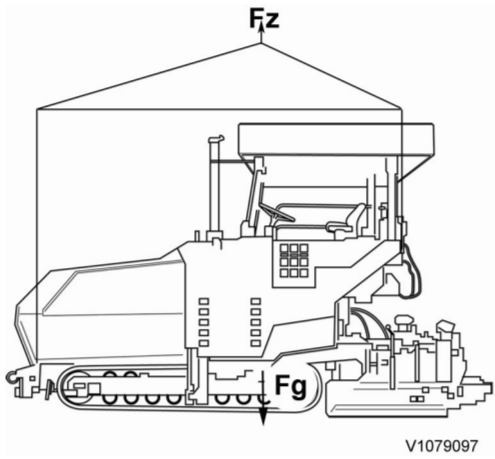

V1079097

Figure 2

Lifting of machine

Position	Descriptions
Fg	Centre of gravity
Fz	Tractive power

To raise the machine, use the stop points provided. Stop points: see picture.



Marking plate - Load/lift

Document Title: Operation numbers for additional work	Function Group: 070	Information Type: Service Information	Date: 4/29/2026
Profile: Tracked Pavers (PAT)			

Operation numbers for additional work

Showing Selected Profile

These operations can be used to identify work that is not included in the time guide or described in the methods in the Service Manual. When these operations are used, a description of the work that has been performed must be provided.

Other work related to engine

Op. no. 070-210

This operation can be used when work has been done related to the engine and function group 2 when no applicable method description was available. When this operation is used, additional information is required:

- Description of work that has been done

Other work related to electrical system

Op. no. 070-310

This operation can be used when work has been done related to the electrical system and function group 3 when no applicable method description was available. When this operation is used, additional information is required:

- Description of work that has been done

Other work related to transmission, gearbox, travel motor, swing motor

Op. no. 070-410

This operation can be used when work has been done related to the transmission, gearbox, travel motor or swing motor and function group 4 when no applicable method description was available. When this operation is used, additional information is required:

- Description of work that has been done

Other work related to drive axle

Op. no. 070-470

This operation can be used when work has been done related to the drive axle and function group 46 when no applicable method description was available. When this operation is used, additional information is required:

- Description of required work that have been done

Other work related to brake system

Op. no. 070-510

This operation can be used when work has been done related to the brake system and function group 5 when no applicable

method description was available. When this operation is used, additional information is required:

- Description of work that has been done

Other work related to steering system

Op. no. 070-610

This operation can be used when work has been done related to the steering system and function group 6 when no applicable method description was available. When this operation is used, additional information is required:

- Description of work that has been done

Other work related to frame link, axle suspension

Op. no. 070-710

This operation can be used when work has been done related to the frame link, axle suspension and other parts related to function group 7 when no applicable method description was available. When this operation is used, additional information is required:

- Description of work that has been done

Other work related to cab, air conditioning

Op. no. 070-810

This operation can be used when work has been done related to the cab, air conditioning and other parts related to function group 8 when no applicable method description was available. When this operation is used, additional information is required:

- Description of work that has been done

Other work related to hydraulic system

Op. no. 070-910

This operation can be used when work has been done related to the hydraulic system and other parts related to function group 9 when no applicable method description was available. When this operation is used, additional information is required:

- Description of work that has been done

Document Title: Alternative fuels	Function Group: 160	Information Type: Service Information	Date: 4/29/2026
Profile: Tracked Pavers (PAT)			

Alternative fuels

Showing Selected Profile

This statement is only valid for Volvo branded engines.

Hydro-treated vegetable oil (HVO) and fatty acid methyl ester (FAME) biodiesel are both made from renewable raw materials such as vegetable oils and animal fats, but they are chemically processed in different ways.

Hydro-treated vegetable oil (HVO)

HVO is created using a chemical process called hydro-treating. Hydro-treating creates an oxygen-free hydrocarbon product that is very similar to distillate diesel fuel and is well suited for use in diesel engines. HVO fuels complying with the CEN diesel fuel standard EN 590:2013 or with the European Fuel Quality Directive 98/70/EC are approved for use in all Volvo Construction Equipment diesel engines with no changes to maintenance intervals. Paraffinic diesel fuels complying with the CEN standard EN 15940 may be used in all machines operating outside the European Union and for EU-certified engines up to the emission level Stage IV. These fuels may also be used for the EU-certified D11, D13 and D16 engines meeting the emission level Stage V.

Biodiesel

Biodiesel is a product made from renewable resources such as vegetable oils or animal fat. Biodiesel that has been chemically processed into fatty acid methyl ester (FAME) can be blended with distillate diesel fuel and used in some diesel engines. Unblended biodiesel is referred to as B100 because it is 100% biodiesel.

Rapeseed methyl ester (RME) is the most common type of FAME used in Europe. Soy methyl ester (SME) and sunflower oil methyl ester (SOME) are the most common types of FAME used in the US.

Although use of FAME biodiesel is now a legal requirement in some markets, it is not as suitable for use in diesel engines as conventional diesel fuel or HVO (hydro-treated vegetable oil).

Biodiesel fuel requirements

The FAME biodiesel blends specified in the table below are approved for use if:

- The biodiesel is pre-blended by the fuel supplier
- The biodiesel used in the blend conforms to EN14214 or ASTM D6751
- The distillate fuel used in the blend meets fuel sulphur requirements
- The distillate fuel used in the blend conforms to EN590 or ASTM D975
- B1-B5 biodiesel blends conform to EN590 or ASTM D975
- B6-B7 biodiesel blends conform to EN590 or ASTM D7467
- B8-B20 biodiesel blends conform to EN16709(B20) or ASTM D7467

Engine emission designation	Engine size	Acceptable blend
EU Stage II / US Tier 2 * EU Stage IIIA / US Tier 3 * EU Stage IIIB / US Tier 4 interim EU Stage IV / US Tier 4 final EU Stage V	Below D4 / 4 litres	Up to B7
EU Stage II / US Tier 2 * EU Stage IIIA / US Tier 3 * EU Stage IIIB / US Tier 4 interim EU Stage IV / US Tier 4 final	D4–D8	Up to B7
EU Stage II / US Tier 2 * EU Stage IIIA / US Tier 3 * US Tier 4 final, special North America arrangement **	D9–D16	Up to B20
EU Stage IIIB / US Tier 4 interim EU Stage IV / US Tier 4 final	D11–D16	Up to B10

EU Stage IIIB / US Tier 4 interim, equipped with High Sulphur Fuel Conversion Kit (only available in unregulated markets)	D4–D16	Up to B20
EU Stage IV / US Tier 4 final, equipped with High Sulphur Fuel Conversion Kit (only available in unregulated markets)		
EU Stage V	D4–D16	Up to B7
<p>* As Tier 2 and Tier 3 emissions regulations ended in 2005 and 2010 respectively, engines produced since then typically meet Stage II / Stage IIIA regulations, allowing their sale in less regulated markets.</p> <p>** With additional restrictions and special operating conditions, equipment used in North America may operate on B20 diesel.</p>		

NOTE!

Failures directly caused by the use of poor quality biofuel, or any other fuel not conforming to standards, are not factory defects and the manufacturer's warranty does not apply.

Maintenance interval requirements

Additional service actions and shorter maintenance intervals are mandatory when using biodiesel blends above B10.

Every 10 hours
<ul style="list-style-type: none"> <input type="radio"/> Check the engine oil and change if it rises above the maximum fill level <input type="radio"/> Inspect the fuel system components and replace as necessary
Half of original interval
<ul style="list-style-type: none"> <input type="radio"/> Change the engine oil and filter <input type="radio"/> Replace the fuel filter(s)
Every year, regardless of operating hours
<ul style="list-style-type: none"> <input type="radio"/> Change the engine oil and filter <input type="radio"/> Clean the fuel tank

Effects of biodiesel on engine oil

Using biodiesel can lead to increased oil dilution. Use engine oil analysis tools frequently to check for fuel dilution and monitor engine oil condition. Check the engine oil level daily. Always change the engine oil if the oil level rises above the maximum fill level.

Effects of biodiesel on fuel systems

Biodiesel dissolves and loosens some fuel system deposits. During the initial conversion to biodiesel, loosened deposits will travel to the fuel filters and require more frequent fuel filter replacements. Start with new fuel filters when using biodiesel for the first time.

Biodiesel is aggressive to some materials used in fuel system components. Inspect seals, hoses, rubber and plastic components every 10 hours. Repair or replace any components that are damaged, softened or leaking. Clean biodiesel from painted surfaces immediately to prevent paint damage.

Biodiesel is more sensitive to bacteria and water contamination than distillate diesel fuel.

- Use as much fuel as possible before refilling the fuel tank in order to prevent bacteria growth if a machine is in regular use, e.g. regularly uses up a tank of fuel within a week. In climates where condensation is a risk, or when the machine is working for short durations, keep the fuel tank full.
- Do not use biodiesel in machines with low utilization or operating time.
- Do not store machines for more than 4 weeks without flushing biodiesel out of the fuel system by operating the machine through at least one full tank of distillate diesel fuel.
- Always follow the manufacturer's storage recommendations and "best-before" dates for each delivery of biodiesel.

Effects of biodiesel on exhaust aftertreatment systems

Biodiesel leaves higher levels of ash in diesel particulate filters and may require more frequent diesel particulate filter (DPF) regeneration and cleaning. Biodiesel can cause deviations in temperatures and functionality of the DPF burner and may cause fault codes or errors.

Biodiesel exhaust gas is aggressive to some materials used in selective catalytic reduction systems (SCR) and may require more frequent cleaning, repairing or replacing of SCR parts.

Effects of biodiesel on cold weather operation

Biodiesel has a high viscosity at temperatures below 0 °C (32 °F) and may cause problems starting the engine. Use a fuel heater or park machines in a heated building if possible.

Effects of biodiesel on engine performance

Biodiesel B100 has about 8% lower energy density compared to regular diesel fuel. Blends equal or lower than B20 have a small impact on engine performance.

Effects of biodiesel on emissions compliance

Engines are certified to comply with U.S. EPA, California and EU emissions standards based upon the use of test fuels with specifications established by these regulatory agencies. Alternative fuels, including biodiesel, that are not substantially similar to the required test fuels may adversely affect engine emissions compliance. As a result, Volvo does not warrant that the engine will conform to applicable Federal or California and EU emissions limits when operated on, or having previously being operated on, biodiesel or other alternative fuels that are not substantially similar to specified test fuels used for certification, nor if biodiesel / regular diesel is used in blends that exceed the recommendations.

However, the use of biodiesel up to a maximum of 20% (B20) in and of itself, will not affect the manufacturer's mechanical warranty as to engine or emissions system, provided the bio fuel used in the blend conforms to the applicable standards and the additional steps outlined herein are followed.

Document Title: Arrival Inspection, according to Inspection Programme	Function Group: 171	Information Type: Service Information	Date: 4/29/2026
Profile: Tracked Pavers (PAT)			

Arrival Inspection, according to Inspection Programme

Op nbr 171-001

Total procedure time (hr): 0.80

1. This Inspection Programme can be found as a PDF file in the document library in PROSIS.

Document Title: Delivery Inspection, according to Inspection Programme	Function Group: 171	Information Type: Service Information	Date: 4/29/2026
Profile: Tracked Pavers (PAT)			

Delivery Inspection, according to Inspection Programme

Op nbr 171-002

Total procedure time (hr): 1.75

1. This Inspection Programme can be found as a PDF file in the document library in PROSIS.

Document Title: Maintenance of Stored Machines, according to Inspection Programme	Function Group: 171	Information Type: Service Information	Date: 4/29/2026
Profile: Tracked Pavers (PAT)			

Maintenance of Stored Machines, according to Inspection Programme

Op nbr 171-003

Total procedure time (hr): 2.50

1. This Inspection Programme can be found as a PDF file in the document library in PROSIS.

Document Title: Washing, external cleaning	Function Group: 1731	Information Type: Service Information	Date: 4/29/2026
Profile: ABG325 Volvo PID:56261480			

Washing, external cleaning

Showing Selected Profile

Valid for serial numbers			
Model	Production site	Serial number start	Serial number stop
ABG325 Volvo PID:56261480			

Op nbr 170-001

NOTE!

When using high pressure cleaners, ensure that no water or vapour comes into contact with electrical components or the control system. Do not use aggressive cleaners which could cause damage to painted surfaces.

1. Remove heavy soiling mechanically by brushing and sweeping. Clean the machine thoroughly with water. Use paint-friendly cleaners.
2. After washing, allow the engine to warm up. This will dry the engine components and electrical connections more quickly.
3. After cleaning: lubricate according to lubrication plan, see [Lubrication](#).

Document Title: Bolted joints, check tightening torque	Function Group: 1731	Information Type: Service Information	Date: 4/29/2026
Profile: ABG325 Volvo PID:56261480			

Bolted joints, check tightening torque

Showing Selected Profile

Valid for serial numbers			
Model	Production site	Serial number start	Serial number stop
ABG325 Volvo PID:56261480			

Op nbr

This is part of another procedure

Check machine during all maintenance work for loosened nuts or threaded connections and tighten with the appropriate tightening torque. Replace loosened self-locking nuts as required.

Document Title: Wiring diagram 1	Function Group: 370	Information Type: Service Information	Date: 4/29/2026
Profile: ABG325 Volvo PID:56261480			

Wiring diagram 1

Showing Selected Profile

Valid for serial numbers			
Model	Production site	Serial number start	Serial number stop
ABG325 Volvo PID:56261480			

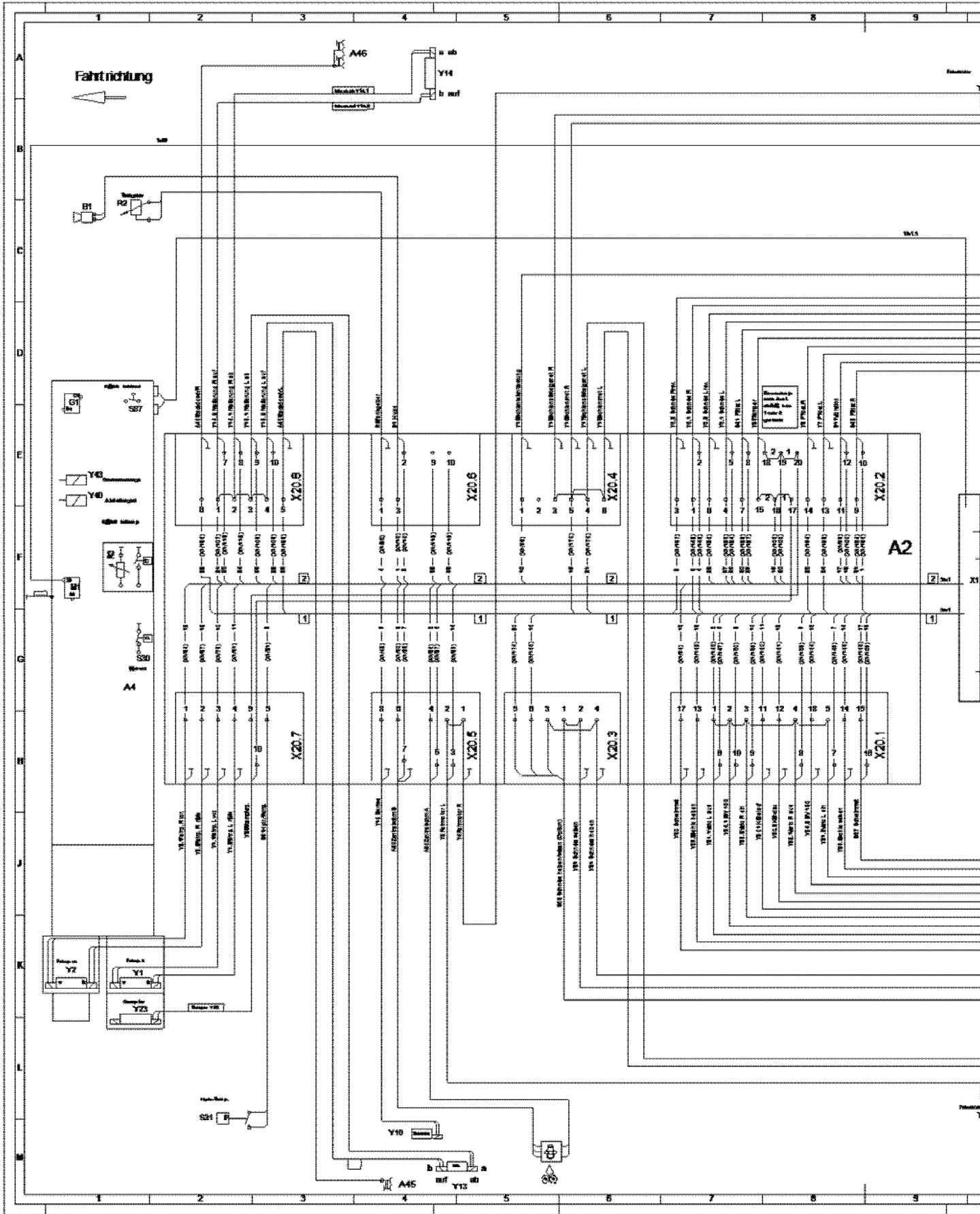

Figure 1
V1081389

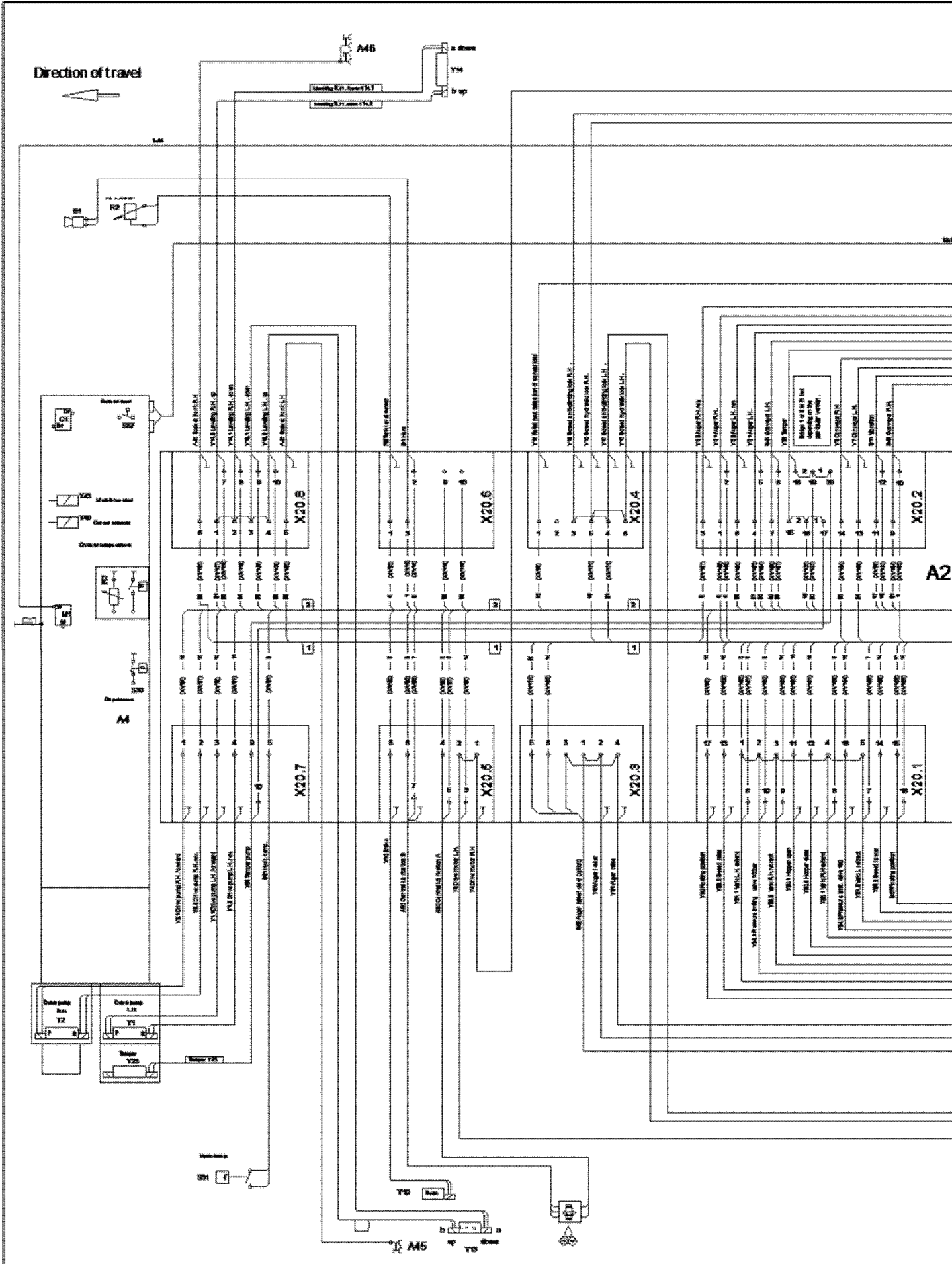

Figure 2

V1081855

Document Title: Wiring diagram 2	Function Group: 370	Information Type: Service Information	Date: 4/29/2026
Profile: ABG325 Volvo PID:56261480			

Wiring diagram 2

Showing Selected Profile

Valid for serial numbers			
Model	Production site	Serial number start	Serial number stop
ABG325 Volvo PID:56261480			

V1081390

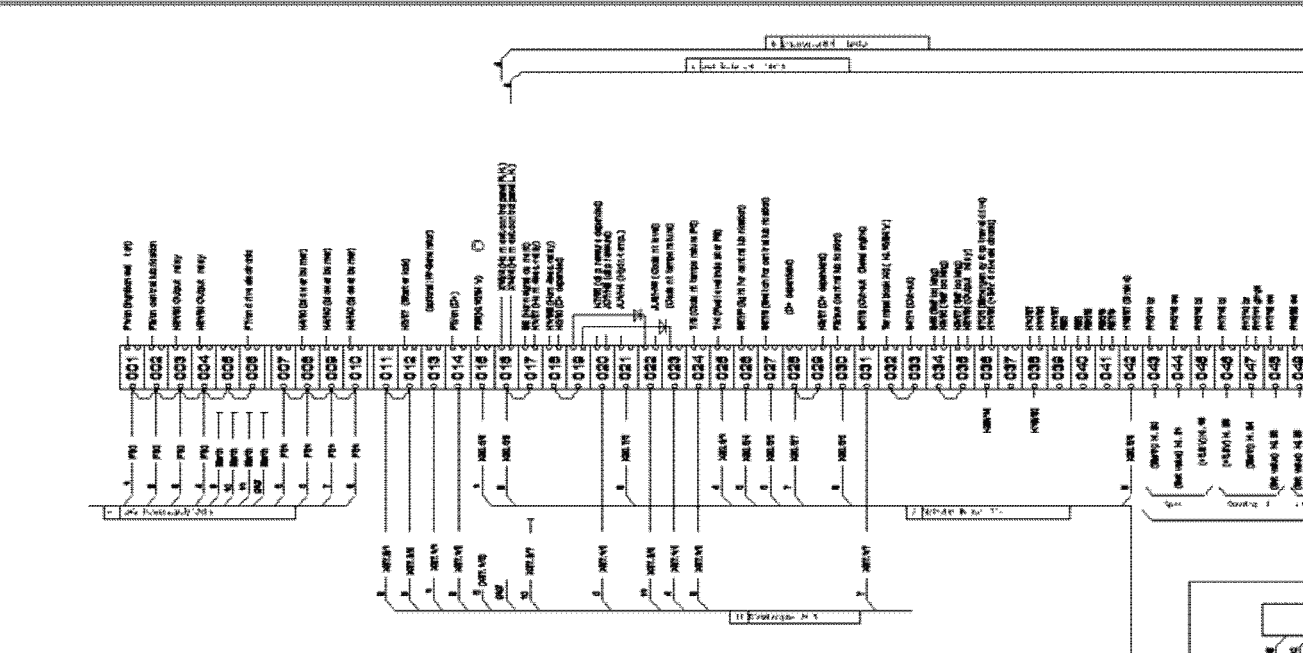
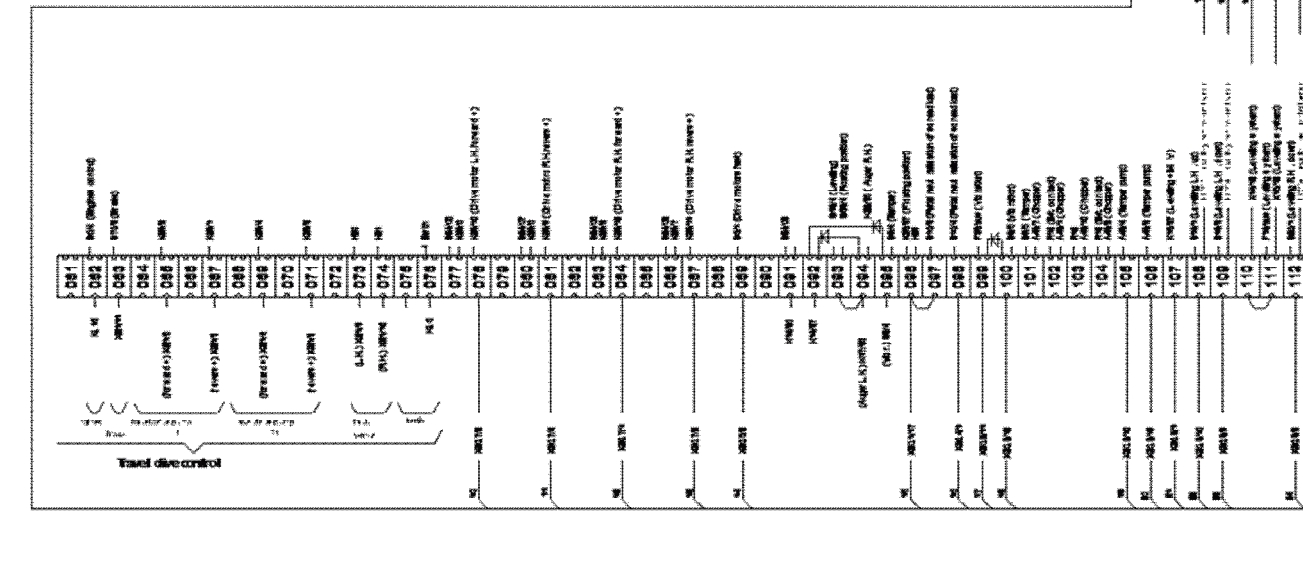
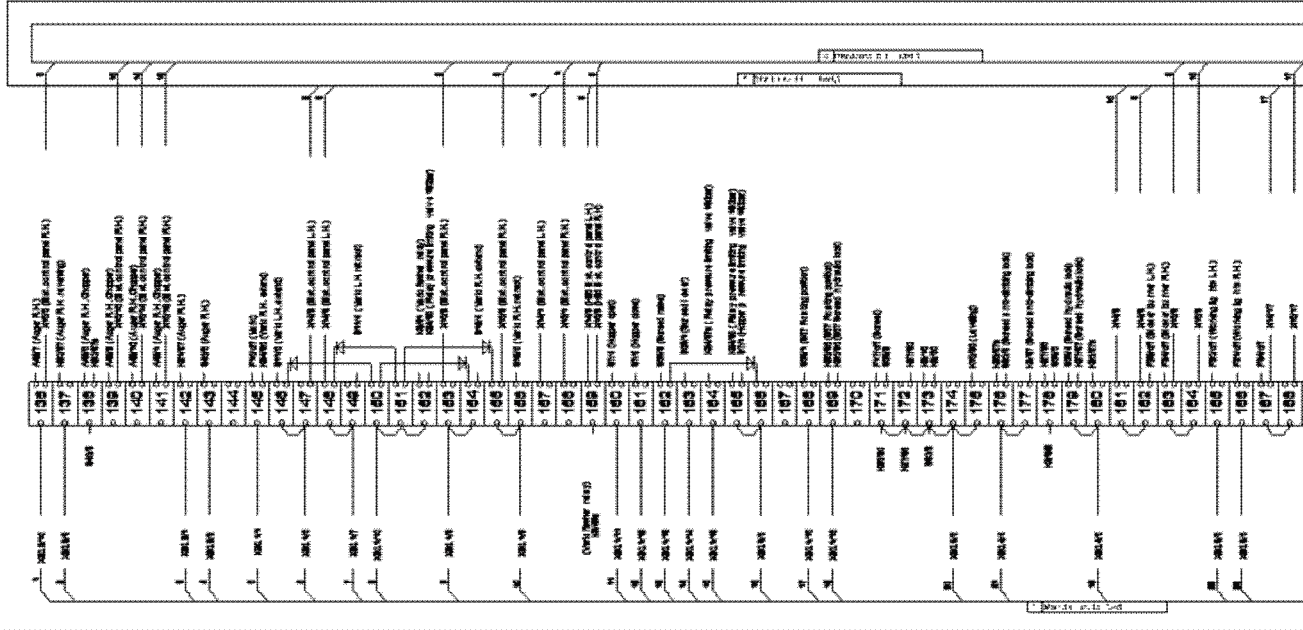

Figure 2
V1081856

Document Title: Wiring diagram 3	Function Group: 370	Information Type: Service Information	Date: 4/29/2026
Profile: ABG325 Volvo PID:56261480			

[Go back to Index Page](#)

Wiring diagram 3

Showing Selected Profile

Valid for serial numbers			
Model	Production site	Serial number start	Serial number stop
ABG325 Volvo PID:56261480			

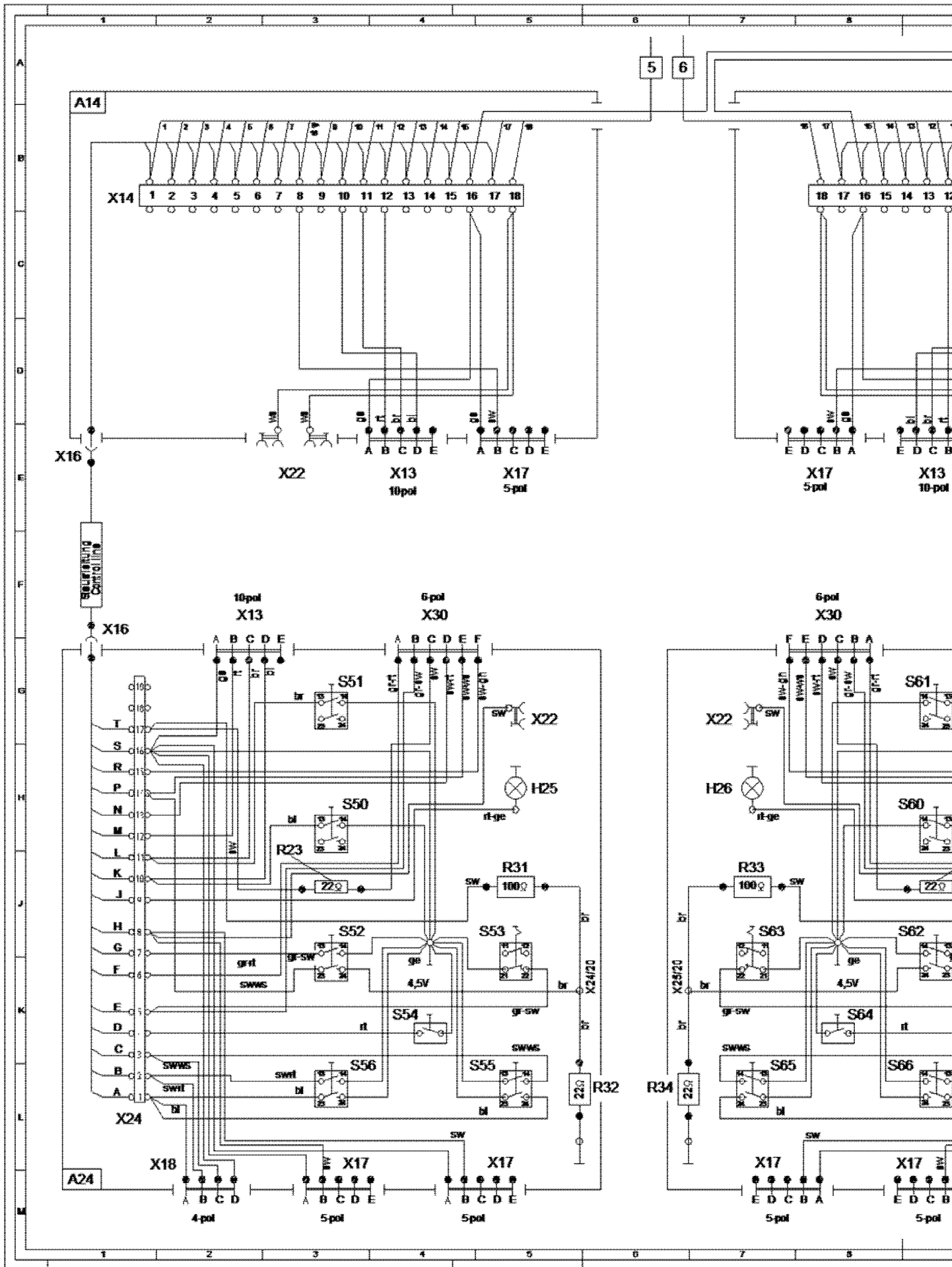

Figure 1
V1081391

Product: ABG325 Volvo Tracked Pavers Service Manual

Full Download: <https://www.arepairmanual.com/downloads/abg325-volvo-tracked-pavers-service-manual/>

V O L V O

Service Information

Document Title: Wiring diagram 3	Function Group: 370	Information Type: Service Information	Date: 4/29/2026
Profile: ABG325 Volvo PID:56261480			

[Go back to Index Page](#)

Wiring diagram 3

Showing Selected Profile

Valid for serial numbers			
Model	Production site	Serial number start	Serial number stop
ABG325 Volvo PID:56261480	Hameln	51	14917

Sample manual. Download All 199 pages at:

<https://www.arepairmanual.com/downloads/abg325-volvo-tracked-pavers-service-manual/>