

Document Title: Complete machine, descriptions	Function Group: 000	Information Type: Service Information	Date: 4/25/2026
Profile: R100E Volvo			

[Go back to Index Page](#)

Complete machine, descriptions

Showing Selected Profile

Valid for option/configuration			
Model	Option no.	Option	Configuration
R100E Volvo		Engine	EU Stage V / US Tier 4 final

Valid for serial numbers			
Model	Production site	Serial number start	Serial number stop
R100E Volvo	Motherwell	121011	129999

Volvo R100E is a two-axle rigid hauler with independent front suspension, a load capacity of 95 metric tonnes (105 short tons). It also has a load volume of 60.4 m³ (2113 ft³). The machine has heavy-duty rear axles with full floating axle shafts, single reduction spiral bevel gear, differential and planetary reduction at each wheel.

Engine

The machine is equipped with a V12 cylinder, four-stroke, turbocharged diesel engine with direct injection and aftercooler. The engine camshaft operates the valves and injectors via push rods. The engine has two cylinder heads, one for each cylinder bank and has four valves per cylinder. The engine has an exhaust aftertreatment system with selective catalytic reduction. There is one engine; QST30C-CM2350-T101.

The engine meets emission regulatory requirements for Stage V / Tier 4 Final US.

The engine features an exhaust aftertreatment system that consists a selective catalytic reduction system, which reduces the content of nitrogen oxide (NO_x). AdBlue®/DEF is injected in the exhaust flow to reduce NO_x.

Temperature-controlled coolant flow maintains the AdBlue®/DEF at operating temperature.

The engine control module monitors the aftertreatment system to ensure reduction of NO_x emissions.

Electrical system

Including the options, as specified, the machine has eight electronic control units.

- **VCU (Vehicle Control Unit)**
Located in the cab, on the rear of the compartment under the seat of the instructor.
Handles all operations of the machine and interfaces with the other control units.
- **ECM (Engine Control Module)**
Located on the left and right-hand side of the engine.
Handles the engine electronics and the interface with the machine.
- **TCM (Transmission Control Module)**
Located in the cab, under the seat of the instructor.
Handles the transmission electronics and the interface with the machine.
- **IMU (Inertial Measuring Unit)**
Located on the rear of the body.
Handles measuring speed and truck angle to enable auto retardation functionality.
- **CCU (Camera Control Unit) – Option**
Located in the cab, under the seat of the instructor.
Handles all operations of the 360° camera system.
- **LWU (Load Weigh Unit) – Option**
Located on the instrument panel, next to the camera system display screen.
Handles the load weigh system.

Sample manual Download All 3295 pages at:

<https://www.arepairmanual.com/downloads/r100e-volvo-rigid-haulers-service-manual/>

Product: R100E Volvo Rigid Haulers Service Manual

Full Download: <https://www.arepairmanual.com/downloads/r100e-volvo-rigid-haulers-service-manual/>

○ **TGW (Telematics Gateway) – Option**

Located in the cab, on the rear of the compartment under the seat of the instructor.

Handles CareTrack (Telematics system for remote monitoring of information from the machine).

○ **TPMU (Tyre Pressure Monitoring Unit) – Option**

Located on the left-hand side of the instrument panel, under the ventilation nozzle.

Handles the monitoring of the tyre pressures.

Power transmission

There are two Allison transmission alternatives; H 8610 ORS (standard) and 9610 ORS (optional).

The **transmissions** are fully automatic electronic control with soft shift feature. Remote mounted in the frame with integral TC 1078 torque converter and planetary gearing. Six forward speeds, one reverse (9610 ORS has two reverse gears). Automatic converter lockup action in all speed ranges with a downshift inhibitor and integral hydraulic retarder.

The **drive axle** is a heavy-duty axle with full floating axle shafts, double reduction spiral bevel gear differential and planetary reduction at each wheel.

Brakes

Brake performance requirements comply with ISO 3450:2011.

Primary

The service brake is operated hydraulically, via the primary service brake pedal. A transmission-mounted variable displacement pump provides hydraulic pressure for brakes and steering. Independent front and rear circuits. Each circuit incorporates a nitrogen accumulator, which stores energy to provide consistent braking response.

Secondary

If there is a primary brake mechanical failure, the parking brake piston is manually modulated. Pressure is applied to the red secondary brake pedal, to slow the machine.

Parking

The parking brake is spring applied and hydraulically operated via a push-button solenoid switch. The switch operates the disc brake on the rear axle brake-packs.

The parking brake remains engaged, irrespective of the brake switching position, on machine start-up. Machine control logic does not permit the brakes to be released until the operator has indicated that they are in control of the machine. Operator control occurs when the operator applies pressure to the footbrake pedal.

NOTE!

Pressure to the footbrake pedal allows the vehicle control unit (VCU) to release the parking brake.

In an emergency, the parking brake push button is used to apply the service and parking brakes. Emergency braking is automatically applied when the engine is switched off or if system pressure falls below a predetermined level. See parking brake for additional information.

Retardation

Manual electronic control of rear disc brakes or hydraulic retarder in the transmission; depending on manual selection. The force of retardation on the rear brake is manually adjusted to six pre-selected stages of variable pressure, for consistent downhill machine control.

Automatic electronic control of rear disc brakes via the vehicle control unit. The retardation lever on the steering column must be set to zero to enable automatic activation.

Steering system

Steering performance complies with ISO 5010:2007.

The machine has an independent hydrostatic steering system with closed-centre steering valve, accumulator and pressure compensating pump.

An accumulator provides uniform steering regardless of engine speed. If there is a loss of engine power, it provides emergency steering.

A low-pressure indicator light warns of system pressure below 83 bar (1200 psi).

Suspension

Front: King pin strut type, independent front wheel suspension with self-contained, variable rate, nitrogen/oil cylinders.

Rear: Variable rate nitrogen/oil cylinders with A-frame linkage and lateral anti-roll bar.

Body

Longitudinal 'V' type floor with integral transverse box-section stiffeners. The body is exhaust heated and rests on resilient impact absorption pads. Body wear surfaces are high hardness (360–440 BHN) abrasion resistant steel. Yield strength of plates 1000 MPa (145000 lbf/in²).

Sample manual. Download All 3295 pages at:

<https://www.arepairmanual.com/downloads/r100e-volvo-rigid-haulers-service-manual/>

The cab features a manually controlled heating and ventilation system with a demist system for the windows. Air conditioning is standard. The cab has a main door to the left-hand side of the driver. The cab also has an emergency exit door to the right-hand side of the driver.

FOPS and ROPS

The cab is approved as a protective cab according to FOPS and ROPS standards. FOPS (ISO 3449:2008 Level II Qualified) is an abbreviation of Falling Objects Protective Structure (roof protection). ROPS (ISO 3471:2008 Qualified) is an abbreviation of Roll Over Protective Structure (roll over protection).

If any part of the protective design of the cab becomes affected by plastic deformation or cracks, the cab must be replaced immediately.

Never make any unauthorised changes to the cab.

For example: lowering the roof height, drilling, welding on of brackets for fire extinguishers, radio aerial or other equipment. Any modifications must, in the first instance, be discussed with your local dealer and personnel at Volvo CE technology department.

They must decide if the modification can lead to the approval becoming invalid.

Hydraulics

Pumps

The hydraulic system consists of three hydraulic pumps; one piston pump type and two gear driven pumps.

There is one pump (piston type) for the steering, brake and body pilot systems. There is one double pump and a single pump for the Oil Cooled Disc Brake (OCDB) system and body hoist system. Both the double and single pumps feed the OCDB system until the body hoist system is activated. During body operations the single pump and one section of the double pump operate the body hoist system. One section of the double pump is used solely as a constant feed to the OCDB system.

Accumulators

The hydraulic system has three accumulators of the piston type, that are pre-charged with nitrogen gas. There is one accumulator for the steering circuit that maintains pressure for instant reaction and provides pressure for emergency steering in a pressure loss situation. There is one accumulator for the front brake system and one accumulator for the rear brake system that maintain pressure in the systems. The rear brake accumulator also maintains constant pressure in the parking brake system. This pressure holds the parking brake in the OFF position when the machine is in operation.

Tipping system

The machine has a body control lever that sends an electric signal via the VCU to an electro-hydraulic hoist valve. The hoist valve controls the hydraulic input to the two tipping/dumping cylinders that control the movement of the body. The machine has a proximity sensor, to control the body movement during the lowering procedure.

Document Title: Complete machine, descriptions	Function Group: 000	Information Type: Service Information	Date: 4/25/2026
Profile: R100E Volvo			

[Go back to Index Page](#)

Complete machine, descriptions

Showing Selected Profile

Valid for option/configuration			
Model	Option no.	Option	Configuration
R100E Volvo		Engine	Tier II

Valid for serial numbers			
Model	Production site	Serial number start	Serial number stop
R100E Volvo	Motherwell	111014	119999

Volvo R100E is a two-axle rigid hauler with independent front suspension, a load capacity of 95 metric tonnes (105 short tons), and a load volume of 60.4 m³ (2113 ft³). The machine has heavy-duty rear axles with full floating axle shafts, single reduction spiral bevel gear, differential and planetary reduction at each wheel.

Engine

The machine is equipped with a V12 cylinder, four-stroke, turbocharged diesel engine with direct injection and aftercooler. The engine camshaft operates the valves and injectors via push rods. The engine has two cylinder heads, one for each cylinder bank, and has four valves per cylinder. There is one engine; QST30C

The engine meets emission requirements for Stage II.

Electrical system

The machine has three control units (ECU).

- **VCU (Vehicle Control Unit)**
Located in the cab, on the rear of the compartment under the instructor’s seat.
Handles all operations of the machine and interfaces with the other control units.
- **ECM (Engine Control Module)**
Located on the engine's left and right side.
Handles the engine electronics and the interface with the machine.
- **TCM (Transmission Control Unit)**
Located in the cab, on the left wall of the compartment under the instructor’s seat.
Handles the transmission electronics and the interface with the machine.

Power transmission

There are two Allison transmission alternatives; H 8610 ORS (standard) and 9610 ORS (optional).

The **transmissions** are fully automatic electronic control with soft shift feature. Remote mounted in the frame with integral TC 1078 torque converter and planetary gearing. Six speeds forward, one reverse (9610 ORS has two reverse). Automatic converter lockup action in all speed ranges. Downshift inhibitor. Integral hydraulic retarder.

The **drive axle** is a heavy duty axle with full floating axle shafts, single reduction spiral bevel gear differential and planetary reduction at each wheel.

Brakes

Service

The service brake is operated hydraulically. A transmission mounted pressure compensating pump provides hydraulic pressure for brakes and steering. Independent circuits front and rear. Each circuit incorporates a nitrogen accumulator which stores energy to provide consistent braking response.

Parking

The parking brake is hydraulically operated with a spring-applied disc brake on the rear axle brake packs.

Retardation

Electronic control of rear disc brakes or hydraulic retarder in transmission.

Emergency

A push button solenoid control applies the service and parking brakes. Emergency brake is automatically applied when the engine is switched off. The parking brake also applies should system pressure fall below a predetermined level.

Brake performance requirements comply with ISO 3450:2011.

Steering system

The machine has an independent hydrostatic steering system with closed-centre steering valve, accumulator and pressure compensating pump. An accumulator provides uniform steering regardless of engine speed. In the event of loss of engine power it provides emergency steering. A low pressure indicator light warns of system pressure below 83 bar (1200 PSI).

Steering performance complies with ISO 5010:2007.

Suspension

Front: King pin strut type independent front wheel suspension with self-contained, variable rate, nitrogen/oil cylinders.

Rear: Variable rate nitrogen/oil cylinders with A-frame linkage and lateral stabilizer bar.

Body

Longitudinal 'V' type floor with integral transverse box-section stiffeners. The body is exhaust heated and rests on resilient impact absorption pads. Body wear surfaces are high hardness (360-440 BHN) abrasion resistant steel. Yield strength of plates 1000 MPa (145000 lbf/in²).

Cab

The cab features a manually controlled heating and ventilation system with demist system for the windows. Air conditioning is standard. The cab has two doors; a main door to the driver's left side, and an emergency exit door to the driver's right side.

FOPS and ROPS

The cab is approved as a protective cab according to FOPS and ROPS standards. FOPS (ISO 3449:2008 Level II Qualified) is an abbreviation of Falling Objects Protective Structure (roof protection) and ROPS (ISO 3471:2008 Qualified) is an abbreviation of Roll Over Protective Structure (roll over protection).

If any part of the cab's protective design features is affected by plastic deformation or cracks, the cab must be replaced immediately.

Never make any unauthorized changes to the cab, e.g., lowering the roof height, drilling, welding on of brackets for fire extinguishers, radio aerial, or other equipment without first discussing the modifications, via a dealer, with personnel at Volvo CE's design and engineering department. They will decide if the modification can lead to the approval becoming invalid.

Hydraulics

The hydraulic system consists of three hydraulic pumps; one piston pump type and two gear driven pumps.

There is one pump (piston type) for the steering, brake and body pilot systems and one double pump and a single pump for the Oil Cooled Disc Brake (OCDB) system and body hoist system. Both the double and single pumps feed the OCDB system until the body hoist system is activated. During body operations the single pump and one section of the double pump operate the body hoist system. One section of the double pump is used solely to feed the OCDB system at all times.

The hydraulic system has three accumulators of the piston type, that are pre-charged with nitrogen gas. There is one accumulator for the steering circuit which maintains pressure for instant reaction and provides pressure for emergency steering in a pressure loss situation. There is one accumulator for the front brake system and one accumulator for the rear brake system which maintain pressure in the systems. The rear brake accumulator also maintains constant pressure in the parking brake system, this holds the parking brake in the OFF position when the machine is in operation.

Tipping system

The machine has a body control lever that sends an electric signal via the VCU to an electro-hydraulic hoist valve. The hoist valve controls the hydraulic input to the two hoist cylinders which control the body's movement. The machine has a proximity sensor, to control the body movement during the lowering procedure.

Document Title: Information and warning decals	Function Group: 000	Information Type: Service Information	Date: 4/25/2026
Profile: R100E Volvo			

[Go back to Index Page](#)

Information and warning decals

Showing Selected Profile

Valid for option/configuration			
Model	Option no.	Option	Configuration
R100E Volvo		Engine	EU Stage V / US Tier 4 final

Valid for serial numbers			
Model	Production site	Serial number start	Serial number stop
R100E Volvo	Motherwell	121011	129999

The operator should know, follow, and pay attention to warnings and information stated on decals and plates. Not all plates/decals are installed on all machines since they are dependent on market and machine.

The decals must be kept free from dirt, so that they are legible and easy to understand. Decals/plates that have been lost, damaged, painted over, or no longer are legible for other reasons, must be replaced immediately.

The part number (order number) of each plate/decal can be found in the Parts Catalogue.

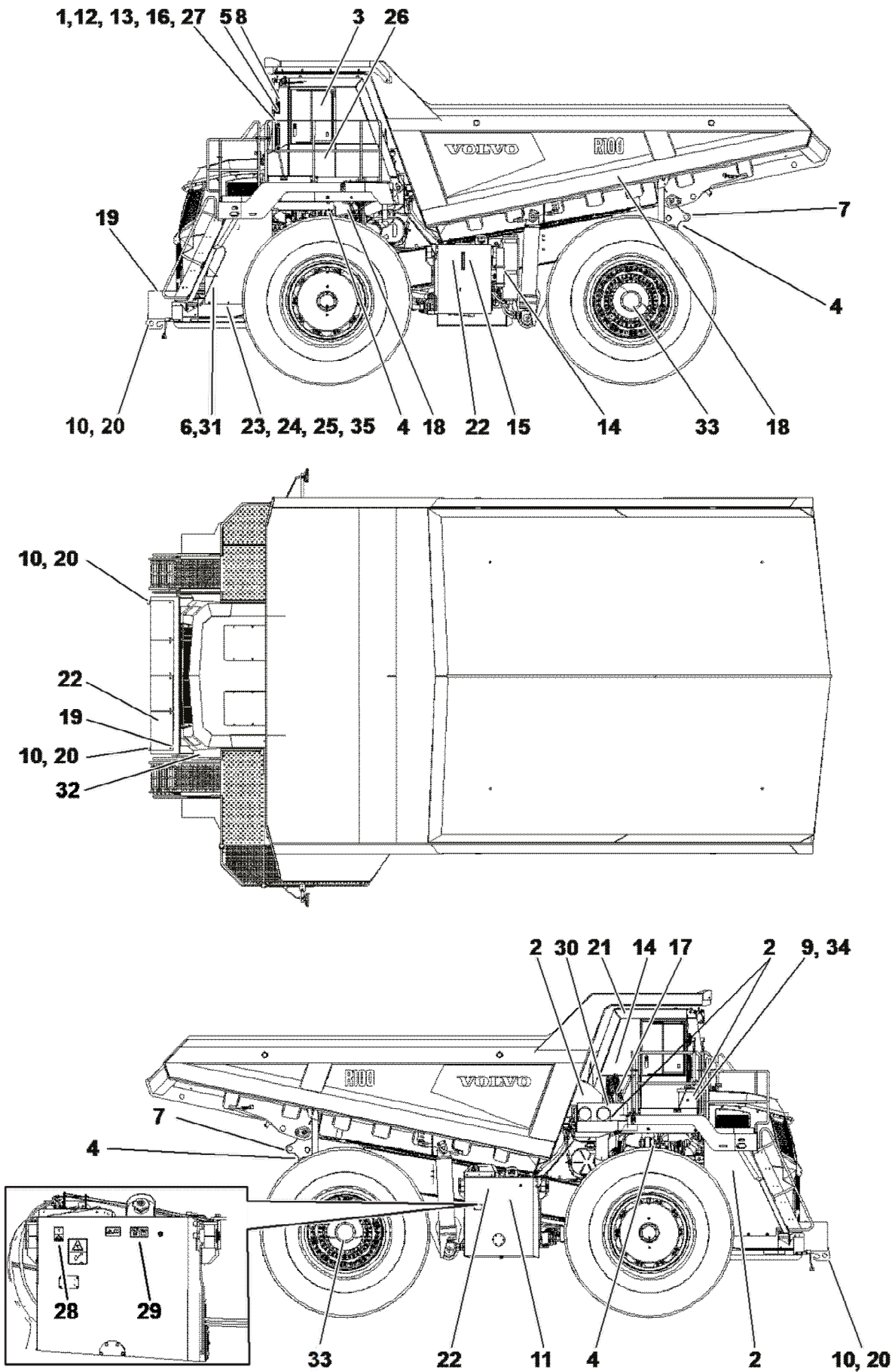

V1188472

Figure 1

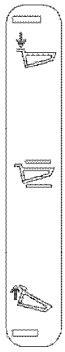

V1188066

Figure 2

1. Body hoist

Spare part number, all regions: 15425054

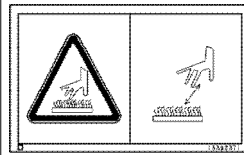

V1187849

Figure 3

2. WARNING! Hot surface

Spare part number USA: 15392367

Spare part number, all other regions: 15392371

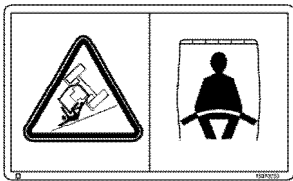

V1187844

Figure 4

3. WARNING! Seat belt

Spare part number USA: 15370752

Spare part number, all other regions: 15370753

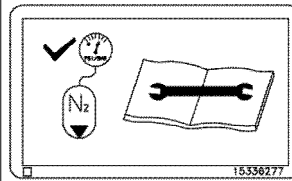

V1187843

Figure 5

4. WARNING! Suspension struts

Spare part number, all regions: 15336277

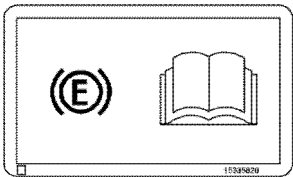

V1187841

Figure 6

5. WARNING! Emergency brake

Spare part number, all regions: 15335820

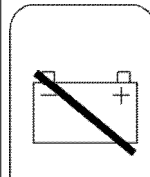

V1187847

Figure 7

6. Battery shut off

Spare part number USA: 1537776

Spare part number, all other regions: 15377808

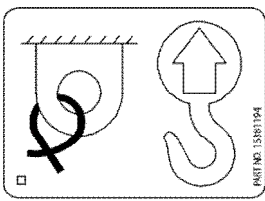

V1187848

Figure 8

7. Hook and tie point

Spare part number, all regions: 15381194

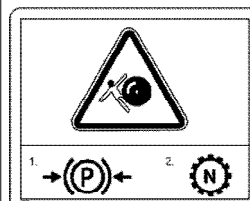

V1187839

Figure 9

8. WARNING! Park brake

Spare part number USA: 15333272

Spare part number, all other regions: 15335788



V1187834

Figure 10

9. CAUTION! Radiator

Spare part number USA: 15333278

Spare part number, all other regions: 15334767

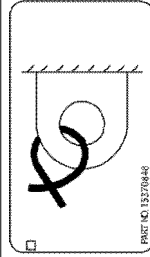

V1187845

Figure 11

10. Tie down point

Spare part number, all regions: 15370848

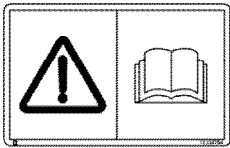

V1187833

Figure 12

11. Handbook

Spare part number USA: 15333275

Spare part number, all other regions: : 15334764

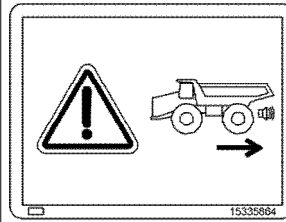

15335864
V1187842

Figure 13

12. WARNING! Reverse alarm

Spare part number, all regions: 15335864

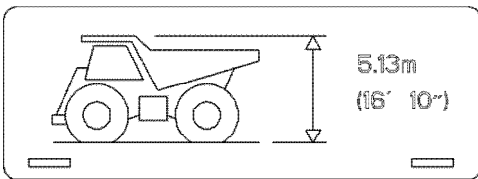

V1188067

Figure 14

13. Height

Spare part number, all regions: 15430221

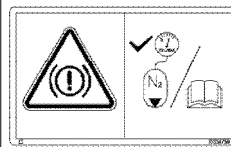

V1187832

Figure 15

14. WARNING! Accumulators

Spare part number USA: 15333270

Spare part number: 15334759

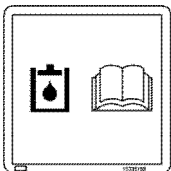

V1187838

Figure 16

15. Sight gauge

Spare part number, all regions: 15335785



15335789
V1187840

Figure 17

16. CAUTION! Cab foam

Spare part number, all regions: 15335789

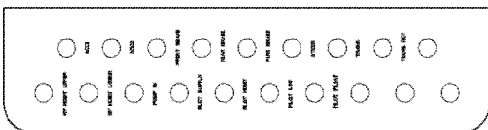

V1187850

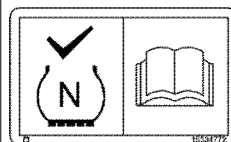

1533777
V1187835

Figure 18

17. Diagnostics
Spare part number USA: 15448236
Spare part number all other regions:

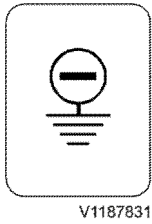

V1187831

Figure 20

19. Battery earth
Spare part number, all regions: 9361787

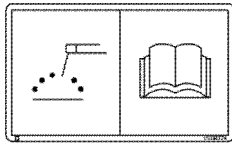

V1187836

Figure 22

21. Welding
Spare part number USA:
Spare part number, all other regions: 15334774



V1187874

Figure 24

23. Product plate
Spare part number: 15433606 (Europe) / 15433607 (Eurasian
Customs Union) / 15433605 (Rest of world) / 15432984
(China)

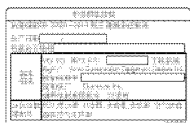

V1188166

Figure 26

25. Supplementary environmental decal plate, China

Figure 19

18. Nitrogen filled tyres
Spare part number USA: 15333283
Spare part number, all other regions: 15334772

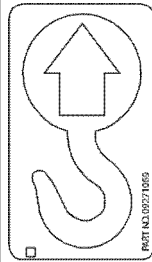

V1187830

Figure 21

20. Hook
Spare part number, all regions: 9271069



V1187837

Figure 23

22. WARNING! Crush hazard — Body supports
Spare part number USA: 15333265
Spare part number, all other regions: 15335749

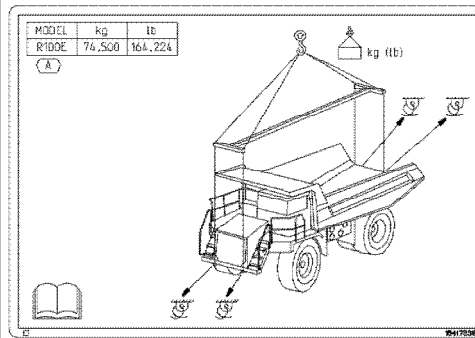

V1187851

Figure 25

24. Safety lift instructions
Spare part number, all regions: 15417338

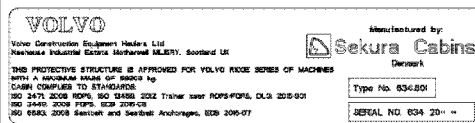

V1188278

Figure 27

26. Cab ROPS/FOPS

Spare part number: 15432988

	O	SPH	MPH		O	SPH	MPH
0	0	0	0	0	0	0	0
5	8	13	8	5	8	13	8
10	16	26	16	10	16	26	16
15	24	39	24	15	24	39	24
20	32	52	32	20	32	52	32
25	40	65	40	25	40	65	40
30	48	78	48	30	48	78	48

V1188373

Figure 28

27. Decline warning

Spare part number USA: 15448468

Spare part number, all other regions: 15442853

Spare part number, all regions: 15433608

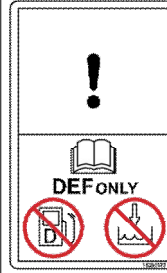

V1188471

Figure 29

28. Diesel exhaust fluid

Spare part number, all regions: 15363065

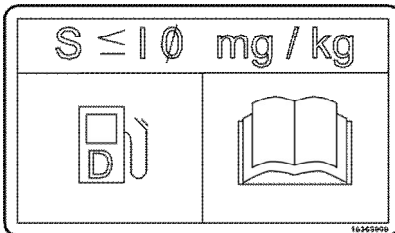

V1188470

Figure 30

29. Fuel

Spare part number USA: 15363064

Spare part number all other regions: 15363909



V1188521

Figure 31

30. No step

Spare part number, all regions: 15392160:

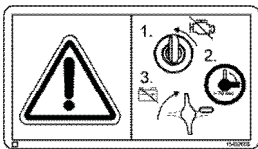

V1188619

Figure 32

31. Battery master switch

Spare part number USA: 15452574

Spare part number, all other regions: 15452608

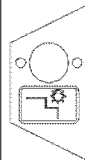

V1188620

Figure 33

32. Access lights

Spare part number, all regions: 15448963

Document Title: Information and warning decals	Function Group: 000	Information Type: Service Information	Date: 4/25/2026
Profile: R100E Volvo			

[Go back to Index Page](#)

Information and warning decals

Showing Selected Profile

Valid for option/configuration			
Model	Option no.	Option	Configuration
R100E Volvo		Engine	Tier II

Valid for serial numbers			
Model	Production site	Serial number start	Serial number stop
R100E Volvo	Motherwell	111014	119999

The operator should know, follow, and pay attention to warnings and information stated on decals and plates. Not all plates/decals are installed on all machines since they are dependent on market and machine.

The decals must be kept free from dirt, so that they are legible and easy to understand. Decals/plates that have been lost, damaged, painted over, or no longer are legible for other reasons, must be replaced immediately.

The part number (order number) of each plate/decals can be found in the Parts Catalogue.

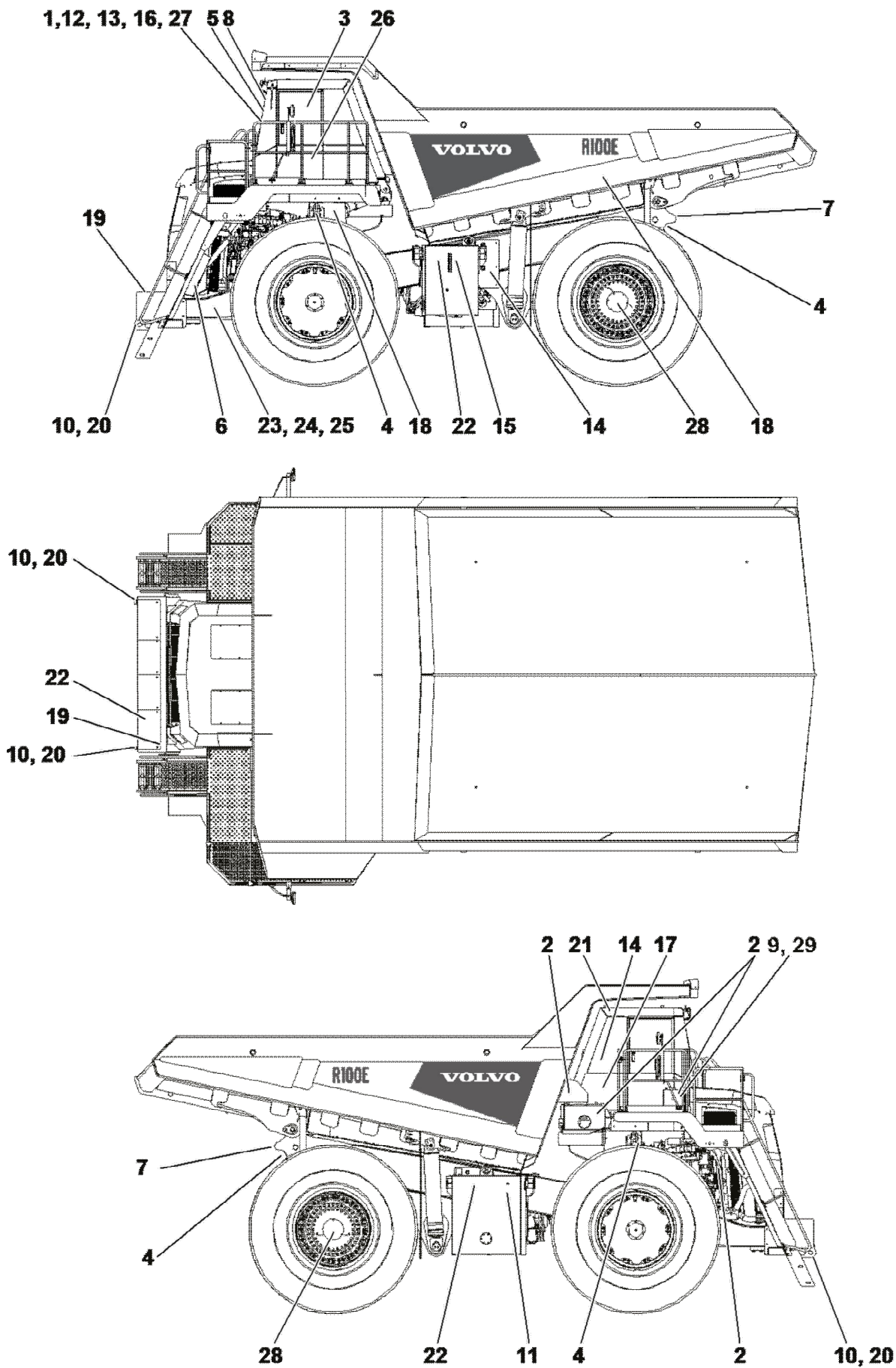

V1187829

Figure 1

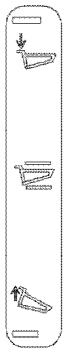

V1188066

Figure 2

1. Body hoist
Spare part number: 15376966

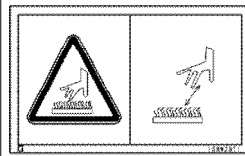

V1187849

Figure 3

2. WARNING! Hot surface
Spare part number: 15392371

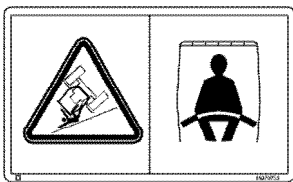

V1187844

Figure 4

3. WARNING! Seat belt
Spare part number: 15370753

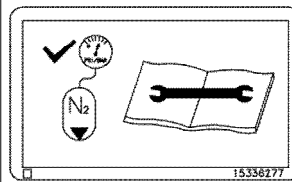

V1187843

Figure 5

4. WARNING! Suspension struts
Spare part number: 15336277

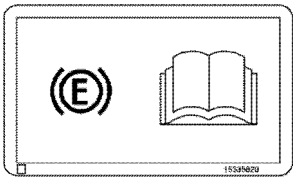

V1187841

Figure 6

5. WARNING! Emergency brake
Spare part number: 15335820

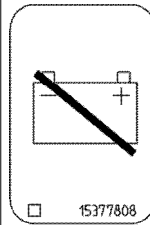

V1187847

Figure 7

6. Battery shut off
Spare part number: 15377808

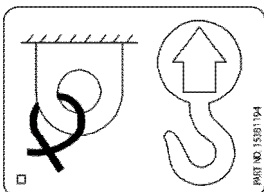

V1187848

Figure 8

7. Hook and tie point
Spare part number: 15381194

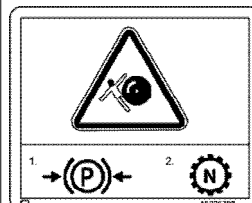

V1187839

Figure 9

8. WARNING! Park brake
Spare part number: 15335788



V1187834

Figure 10

9. CAUTION! Radiator
Spare part number: 15334767

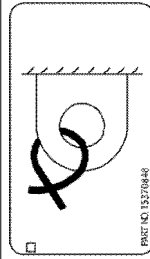

V1187845

Figure 11

10. Tie down point
Spare part number: 15370848

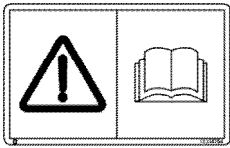

V1187833

Figure 12

11. Handbook
Spare part number: 15334764

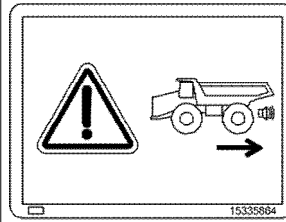

V1187842

Figure 13

12. WARNING! Reverse alarm
Spare part number: 15335864

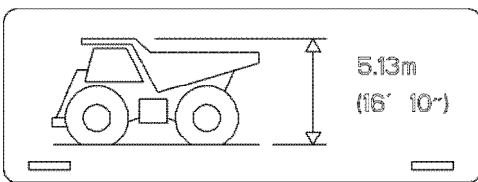

V1188067

Figure 14

13. Height
Spare part number: 15430221

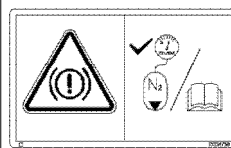

V1187832

Figure 15

14. WARNING! Accumulators
Spare part number: 15334759

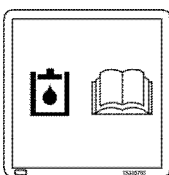

V1187838

Figure 16

15. Sight gauge
Spare part number: 15335785



V1187840

Figure 17

16. CAUTION! Cab foam
Spare part number: 15335789

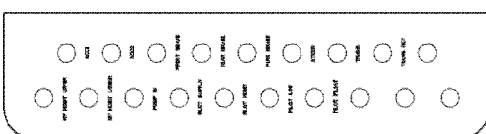

V1187850

Figure 18

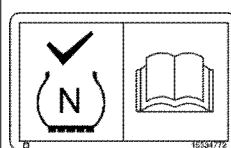

V1187835

17. Diagnostics
Spare part number: 15416963

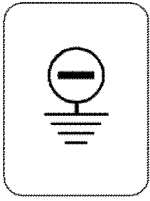

V1187831

Figure 20

19. Battery earth
Spare part number: 9361787

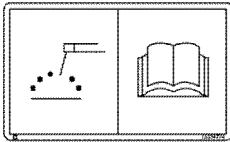

V1187836

Figure 22

21. Welding
Spare part number: 15334774

Figure 19

18. Nitrogen filled tyres
Spare part number: 15334772

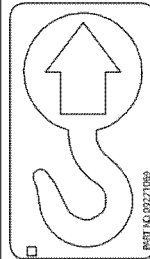

V1187830

Figure 21

20. Hook
Spare part number: 9271069



V1187837

Figure 23

22. WARNING! Crush hazard — Body supports
Spare part number: 15335749



V1187874

Figure 24

23. Product plate
Spare part number: 15419291 (Europe) / 15419292 (Eurasian Customs Union) / 15419290 (Rest of world)

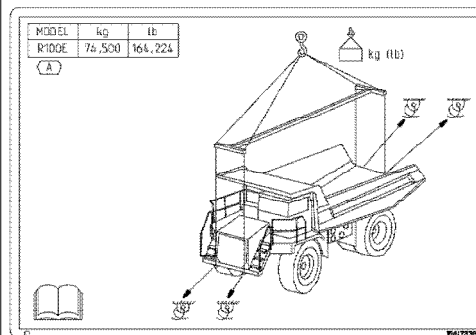

V1187851

Figure 25

24. Safety lift instructions
Spare part number: 15417338

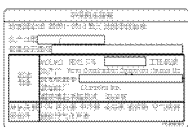

V1188166

Figure 26

25. Supplementary environmental decal plate, China
Spare part number: 15432988

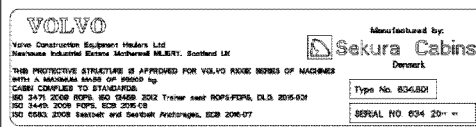

V1188278

Figure 27

26. Cab ROPS/FOPS
Spare part number: 15433608

Document Title: Product identification plates	Function Group: 000	Information Type: Service Information	Date: 4/25/2026
Profile: R100E Volvo			

Product identification plates

Showing Selected Profile

Valid for serial numbers			
Model	Production site	Serial number start	Serial number stop
R100E Volvo			

The illustration and text below show the product plates that should be found on the machine.

When ordering spare parts and when making enquiries by telephone or correspondence, the model designation and **Product Identification Number (PIN)** should be stated.

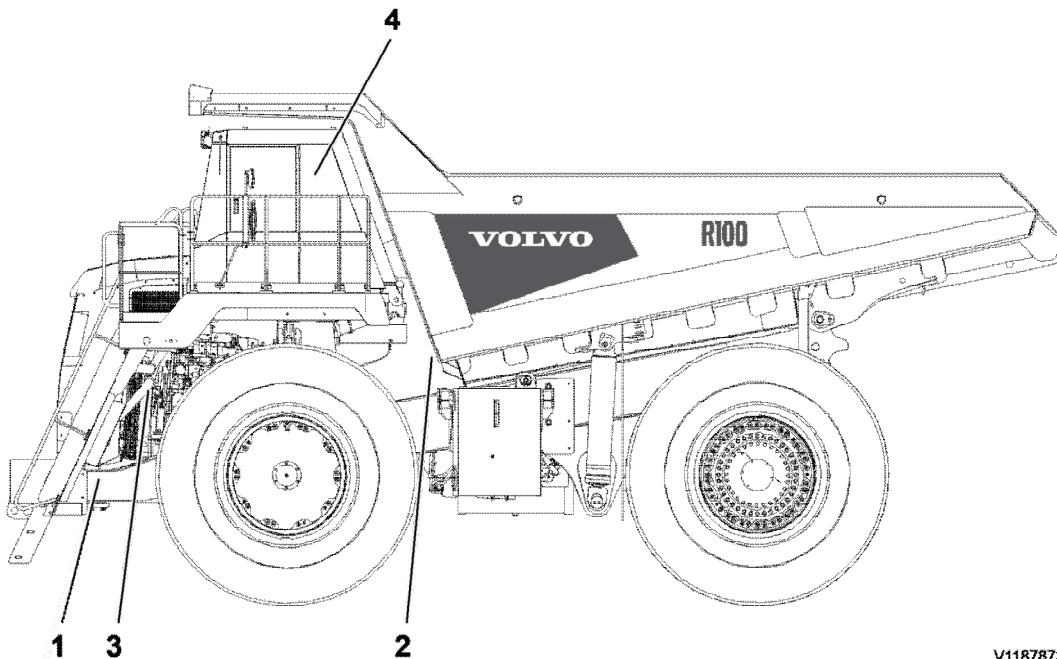

V1187873

Figure 1

1. The product plate is located on the left side of the machine's frame by the access steps, and includes:
 - manufacturer's name and address
 - model/type number and complete machine
 - Product Identification Number (PIN)**
 - machine weight (machine's most common configuration)
 - engine power
 - year of manufacture
 - month of manufacture (only countries within Eurasian Customs Union)
 - country of manufacture
 - assembled in

- space for CE-mark (only countries within EU/EEC) or EAC-mark (only countries within Eurasian Customs Union)

2. The transmission's type designation and serial number are located on its lower right side of the rear housing.
3. The engine's type designation, part number, and serial number are located on the left hand side of the aftercooler housing.
4. Cab type, type approval, and serial number are located on the left side in the cab, on the seat mounting frame.

Product plates

Volvo Construction Equipment	
Volvo Construction Equipment Haulers Ltd Newhouse Industrial Estate, Motherwell Scotland, ML1 5RY	
Type/Model	<input type="text"/>
Product Name	<input type="text"/>
Product Identification Number	<input type="text"/>
Machine mass kg	<input type="text"/>
Nominal power kW	<input type="text"/>
Manufacturing year	<input type="text"/>
Made in <input type="text"/>	Assembled in <input type="text"/>
VOLVO	

V1187784

Figure 2

Countries within EU/EEC

Volvo Construction Equipment	
Volvo Construction Equipment Haulers Ltd Newhouse Industrial Estate, Motherwell Scotland, ML1 5RY	
Type/Model	<input type="text"/>
Product Name	<input type="text"/>
Product Identification Number	<input type="text"/>
Machine mass kg	<input type="text"/>
Nominal power kW	<input type="text"/>
Manufacturing year	<input type="text"/>
Made in <input type="text"/>	Assembled in <input type="text"/>
VOLVO	

V1187783

Figure 3

Worldwide (not within EU/EEC or Eurasian Customs Union)

Volvo Construction Equipment
Volvo Construction Equipment Haulers Ltd
Newhouse Industrial Estate, Motherwell, Scotland, ML1 5RY

Type/Model
Product Identification Number
Machine mass kg
Engine net power kW
Manuf. year/Month /
Made in Assembled in

EAC

VOLVO 1563607

V1187785

Figure 4

Countries within Eurasian Customs Union

Document Title: Measurement conversion tables	Function Group: 030	Information Type: Service Information	Date: 4/25/2026
Profile: Rigid Haulers (RHA)			

Measurement conversion tables

Length

Unit	cm	m	km	in	ft	yd	mile
cm	1	0.01	0.00001	0.3937	0.03281	0.01094	0.000006
m	100	1	0.001	39.37	3.2808	1.0936	0.00062
km	100000	1000	1	39370.7	3280.8	1093.6	0.62137
in	2.54	0.0254	0.000025	1	0.08333	0.02777	0.000015
ft	30.48	0.3048	0.000304	12	1	0.3333	0.000189
yd	91.44	0.9144	0.000914	36	3	1	0.000568
mile	160930	1609.3	1.6093	63360	5280	1760	1

1 mm = 0.1 cm - 1 mm = 0.001 m

Area

Unit	cm ²	m ²	km ²	a	ft ²	yd ²	in ²
cm ²	1	0.0001	-	0.000001	0.001076	0.000012	0.155000
m ²	10000	1	0.000001	0.01	10.764	1.1958	1550.000
km ²	-	1000000	1	10000	1076400	1195800	-
a	0.01	100	0.0001	1	1076.4	119.58	-
ft ²	-	0.092903	-	0.000929	1	0.1111	144.000
yd ²	-	0.83613	-	0.008361	9	1	1296.00
in ²	6.4516	0.000645	-	-	0.006943	0.000771	1

1 ha = 100 a - 1 mile² = 259 ha = 2.59 km²

Volume

Unit	cm ³ = cc	m ³	l	in ³	ft ³	yd ³
cm ³ = ml	1	0.000001	0.001	0.061024	0.000035	0.000001
m ³	1000000	1	1000	61024	35.315	1.30796
dm ³ (l)	1000	0.001	1	61.024	0.035315	0.001308
in ³	16.387	0.000016	0.01638	1	0.000578	0.000021
ft ³	28316.8	0.028317	28.317	1728	1	0.03704
yd ³	764529.8	0.76453	764.53	46656	27	1

1 gal (US) = 3785.41 cm³ = 231 in³ = 0.83267 gal (UK)

Weight

Unit	g	kg	t	oz	lb
g	1	0.001	0.000001	0.03527	0.0022
kg	1000	1	0.001	35.273	2.20459
t	1000000	1000	1	35273	2204.59

oz	28.3495	0.02835	0.000028	1	0.0625
lb	453.592	0.45359	0.000454	16	1
1 ton (metric) = 1.1023 ton (US) = 0.9842 ton (UK)					

Pressure

Unit	kp/cm ²	bar	Pa=N/m ²	kPa	lbf/in ²	lbf/ft ²
kp/cm ²	1	0.98067	98066.5	98.0665	14.2233	2048.16
bar	1.01972	1	100000	100	14.5037	2088.6
Pa=N/m ²	0.00001	0.001	1	0.001	0.00015	0.02086
kPa	0.01020	0.01	1000	1	0.14504	20.886
lbf/in ²	0.07032	0.0689	6894.76	6.89476	1	144
lbf/ft ²	0.00047	0.00047	47.88028	0.04788	0.00694	1
kg/cm ² = 735.56 Dry (mmHg) = 0.96784 atm						

Unit explanations

Unit	abbreviation
Newton meter	Nm
Kilopoundmeter	kpm
Kilopascal	kPa
Megapascal	MPa
Kilowatt	kW
kilojoule	kJ
British thermal unit	Btu
Calorie	ca

Approx. conversion

SI unit	Conversion factor	Non SI	Conversion factor	SI
Torque				
Nm	x10.2	=kg/cm	x0.8664	=lb in
Nm	x0.74	=lbf·ft	x1.36	=Nm
Nm	x0.102	=kg/m	x7.22	=lbft
Pressure (Pa = N/m²)				
kPa	x4.0	=in.H ₂ O	x0.249	=kPa
kPa	x0.30	=in.Hg	x3.38	=kPa
kPa	x0.145	=psi	x6.89	=kPa
bar	x14.5	=psi	x0.069	=bar
kp/cm ²	x14.22	=psi	x0.070	=kp/cm ²
N/mm ²	x145.04	=psi	x0.069	=bar
MPa	x145	=psi	x0.00689	=MPa
Power (W = J/s)				
kW	x1.36	=hp(cv)	x0.736	=kW
kW	x1.34	=bhp	x0.746	=kW
kW	x0.948	=Btu/s	x1.055	=kW
W	x0.74	=ft·lb/s	x1.36	=W
Energy (J = Nm)				

kJ	x0.948	=Btu	x1.055	=kJ
J	x0.239	=calorie	x4.19	=J
Speed and acceleration				
m/s ²	x3.28	=ft/s ²	x0.305	=m/s ²
m/s	x3.28	=ft/s	x0.305	=m/s
km/h	x0.62	=mph	x1.61	=km/h
Horsepower/torque				
Bhp x5252 rpm= TQ (lb-ft)			TQ x rpm 5252=bhp	
Temperature				
°C =(°F-32)/1.8			°F =(°C x1.8) +32	
Flow factor				
l/min (dm ³ /min)	x0.264	= US gal/min	x3.785	=liter/min

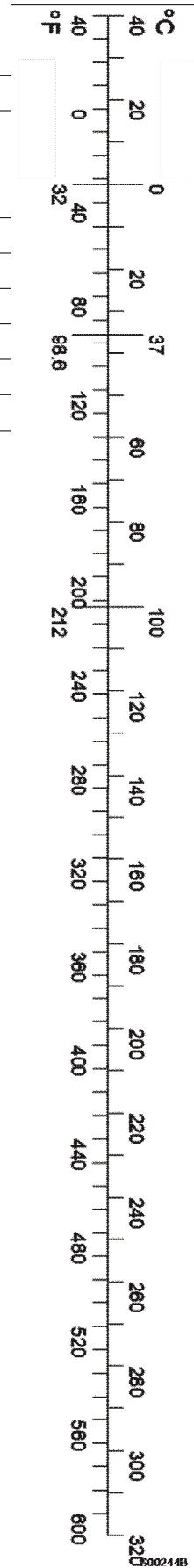

Document Title: Standard tightening torques	Function Group: 030	Information Type: Service Information	Date: 4/25/2026
Profile: R100E Volvo			

Standard tightening torques

Showing Selected Profile

Valid for serial numbers			
Model	Production site	Serial number start	Serial number stop
R100E Volvo			

NOTE!

Torque values should be increased by 10% for flange bolts type U6FS.

Bolts and nuts should be cleaned and lubricated with oil.

Fastener cross reference

Imperial		Metric	
Bolts + Screws	Nuts	Bolts + Screws	Nuts
GM 300–M (SAE Grade 8)	GM 301–M	Class 12.9	GM 510–M (10)
GM 290–M (SAE Grade 7)	GM 301–M	Class 10.9	GM 510–M (10)
GM 280–M (SAE Grade 5)	GM 286–M	Class 9.8	GM 510–M (10)
GM 260–M (SAE Grade 2)	GM 284–M	Class 8.8	GM 510–M (9)

The tightening torques in the following tables apply to bolts and nuts with tensile strength noted below. The tables should be used as a general instruction for tightening bolts and nuts without specified values.

NOTE!

The values in the tables can be exceeded up to 15%

Imperial fasteners

	GM 260–M (SAE Grade 2)	GM 280–M (SAE Grade 5)	GM 290–M (SAE Grade 7)	GM 300–M (SAE Grade 8)
Size	Nm (lbf ft)	Nm (lbf ft)	Nm (lbf ft)	Nm (lbf ft)
1/4–20	5 (4)	8 (6)	11 (8)	12 (9)
1/4–28	7 (5)	9 (7)	12 (9)	14 (10)
5/16–18	11 (8)	18 (13)	22 (16)	24 (18)
5/16–24	12 (9)	19 (14)	24 (18)	27 (20)
3/8–16	20 (15)	31 (23)	38 (28)	43 (32)
3/8–24	23 (17)	34 (25)	43 (32)	49 (36)
7/16–14	33 (24)	47 (35)	58 (43)	68 (50)
7/16–20	37 (27)	54 (40)	68 (50)	79 (58)
1/2–13	50 (37)	75 (55)	94 (69)	106 (78)
1/2–13	56 (41)	88 (65)	106 (78)	122 (90)
9/16–12	75 (55)	108 (80)	136 (100)	156 (115)
9/16–18	81 (60)	122 (90)	149 (110)	176 (130)

5/8-11	102 (75)	149 (110)	190 (155)	217 (160)
5/8-18	115 (85)	169 (125)	210 (155)	244 (180)
3/4-10	176 (130)	271 (200)	332 (245)	380 (280)
3/4-16	203 (150)	298 (220)	366 (270)	420 (310)
7/8-9	169 (125)	434 (320)	536 (395)	610 (450)
7/8-14	190 (140)	488 (360)	590 (435)	678 (500)
1-8	258 (190)	651 (480)	800 (590)	915 (675)
1-12	285 (210)	719 (530)	881 (650)	1003 (740)
1-14	285 (210)	732 (540)	902 (665)	1030 (760)
1-1/8-7	366 (270)	800 (590)	1132 (835)	1302 (960)
1-1/8-12	407 (300)	902 (665)	1274 (940)	1458 (1075)
1-1/4-7	515 (380)	1132 (835)	1600 (1180)	1830 (1350)
1-1/4-12	569 (420)	1254 (925)	1776 (1310)	2034 (1500)
1-3/8-6	664 (490)	1478 (1090)	2095 (1545)	2400 (1770)
1-3/8-12	759 (560)	1688 (1245)	2393 (1765)	2739 (2020)
1-1/2-6	881 (650)	1966 (1450)	2786 (2055)	3186 (2350)
1-1/2-12	990 (730)	2217 (1635)	3145 (2320)	3593 (2650)
1-1/2-8	936 (690)	2088 (1540)	2962 (2185)	3340 (2500)
1-3/4-5			4393 (3240)	5017 (3700)
1-3/4-12			5091 (3755)	5830 (4300)
1-7/8-8			6006 (4430)	6874 (5070)
1-7/8-12			6305 (4650)	7213 (5320)
2-4-1/2			6623 (4885)	7565 (5580)
2-12			7687 (5670)	8786 (6480)
2-8			7342 (5415)	8406 (6200)
2-1/4-4-1/2			9701 (7155)	11091 (8180)
2-1/4-12			11050 (8150)	12636 (9320)
2-1/4-8			10142 (7840)	12148 (8960)
2-1/2-12			15280 (11270)	17463 (12880)

Metric fasteners

	Class 8.8	Class 9.8	Class 10.9	Class 12.9
Size	Nm (lbf ft)	Nm (lbf ft)	Nm (lbf ft)	Nm (lbf ft)
M 1.6 x 0.35		0.20 (0.15)		0.20 (0.15)
M 1.6 x 0.20		0.25 (0.20)		0.40 (0.30)
M 2.0 x 0.40		0.25 (0.20)		0.45 (0.30)
M 2.0 x 0.25		0.45 (0.30)		0.45 (0.30)
M 2.0 x 0.45		0.25 (0.20)		0.45 (0.30)
M 2.2 x 0.35		1 (0.75)		1 (0.75)
M 3.0 x 0.5		1 (0.75)		2 (1.5)
M 3.0 x 0.35		1 (0.75)		2 (1.5)
M 3.5 x 0.60		2 (1.5)		3 (2)
M 4.0 x 0.70		3 (2)		4 (3)
M 4.0 x 0.35		3 (2)		5 (3)
M 5.0 x 0.80		5 (4)		8 (6)
M 5.0 x 0.50		6 (4)		9 (6)
M 6.0 x 1.00		9 (6)		13 (10)
M 6.3 x 1.00		10 (8)	13 (10)	16 (11)

M 6.0 x 0.75		10 (7)	12 (9)	14 (10)
M 8.0 x 1.25		21 (15)	27 (20)	32 (23)
M 8.0 x 1.00		23 (17)	29 (21)	34 (25)
M 10.0 x 1.50		42 (31)	54 (39)	63 (46)
M 10.0 x 1.25		45 (32)	57 (41)	67 (48)
M 12.0 x 1.75		74 (53)	94 (68)	110 (80)
M 12.0 x 1.25		81 (58)	103 (74)	121 (87)
M 14.0 x 2.00		118 (85)	151 (109)	176 (127)
M 14.0 x 1.50		128 (92)	163 (118)	190 (137)
M 16.0 x 2.00	169 (122)		234 (169)	274 (197)
M 16.0 x 1.50	181 (130)		250 (180)	292 (211)
M 18.0 x 2.50	234 (169)		323 (234)	378 (273)
M 18.0 x 1.50	263 (190)		363 (262)	425 (307)
M 20.0 x 2.50	330 (239)		457 (330)	534 (386)
M 20.0 x 1.50	367 (265)		507 (366)	593 (428)
M 22.0 x 2.50	451 (325)		623 (450)	728 (526)
M 22.0 x 1.50	495 (357)		648 (494)	800 (577)
M 24.0 x 3.00	571 (412)		790 (570)	923 (667)
M 24.0 x 2.00	623 (450)		861 (622)	1007 (727)
M 27.0 x 3.00	837 (605)		1158 (836)	1354 (977)
M 27.0 x 2.00	903 (652)		1250 (902)	1461 (1055)
M 30.0 x 3.50	1135 (820)		1570 (1134)	1835 (1325)
M 30.0 x 2.00	1258 (908)		1740 (1256)	2034 (1468)
M 30.0 x 1.50	1300 (939)		1799 (1299)	2102 (1518)
M 36.0 x 4.00	1985 (1433)		2745 (1982)	3208 (2317)
M 36.0 x 3.00	2102 (1517)		2907 (2099)	3398 (2453)

Document Title: Tyre equipment and recommended pressures	Function Group: 030	Information Type: Service Information	Date: 4/25/2026
Profile: R100E Volvo			

Tyre equipment and recommended tyre pressures

Showing Selected Profile

Valid for serial numbers			
Model	Production site	Serial number start	Serial number stop
R100E Volvo			

NOTE!

It is recommended that for listed tyres, the user should consult the tyre manufacturer and evaluate all job conditions in order to make the proper selection. If optional tyres are used or if the machine is used in a different application, the tyre manufacturer should be contacted for information about the correct tyre pressure.

Standard Tyres

Air pressure in tyres at 163000 kg load and maximum speed			
Tyre equipment		Front	Rear
Standard - Bridgestone 27.00 R49 VMTP	kPa (psi)	703.3 (102)	703.3 (102)
	Wheel Rim Width	Inch	19.5

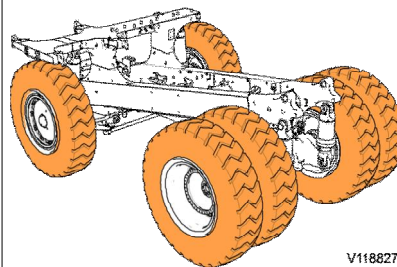

Figure 1

Optional Tyres

Option number	Manufacturer	Tread	Compound
OPL42030	Michelin	XDTA4	
OPL42031	Goodyear	RL4J	
OPL42033	Bridgestone	VRLS	E2A
OPL42270	Bridgestone	VMTS	
OPL43240	Michelin	XKD1A	
OPL44140	Michelin	XP73	
OPL44679	Bridgestone	VZTS	
OPL44846	Belshina	FT115	
OPL44932	Michelin	XDRA	E4

OPL45593	Bridgestone	VMPT	3A
OPL46282	Belshina	BEL132	
OPL46377	Magna	MB440	
OPL46886	Michelin	XDR2B	E4R
OPL46926	Bridgestone	VMPT	S2

Document Title: Weights	Function Group: 030	Information Type: Service Information	Date: 4/25/2026
Profile: R100E Volvo			

[Go back to Index Page](#)

Weights

Showing Selected Profile

Valid for option/configuration			
Model	Option no.	Option	Configuration
R100E Volvo		Engine	EU Stage V / US Tier 4 final

Valid for serial numbers			
Model	Production site	Serial number start	Serial number stop
R100E Volvo	Motherwell	121011	129999

	kg (approx.)	lb
Total Operating Weight (loaded)	166280	366584
Net Vehicle Weight	69550	153332
Engine, complete (dry weight)	3045	6713
Transmission (dry weight)	1714	3779
Front axle and suspension (dry weight)	5395	11894
Rear axle (dry weight)	10550	23259

	Front Axle	Rear Axle
Weight Distribution (empty) %	47.4	52.6
Weight Distribution (loaded) %	33.2	66.8

Assemblies removed for transportation		
	kg (approx)	lbs
Cab	1100	2425
Dump body	16200	35715
Hand rail 1	14.6	32.2
Hand rail 2	14.2	31.3
Left-hand platform	138.7	305.8
Rock ejector	33.6	74.1
Wheel (each)	2000	4409

Dump body options		
Ensure that the GVW of the machine is not exceed when these options are fitted.		
	kg (approx)	lbs
Canopy right-hand	58.5	129
Coal body	16350.4	36046.5
Side extension 350 mm	927	2044
Side extension 150 mm	575	1268

Skip extension	1133.7	2500
Spill guard right-hand	124	273
Spill guard left-hand	140	309
Spill guard support (each)	7.4	16.3
Wear plates - full	5326.8	11743.5
Wear plates - half	3407.5	7512

Document Title: Weights	Function Group: 030	Information Type: Service Information	Date: 4/25/2026
Profile: R100E Volvo			

[Go back to Index Page](#)

Weights

Showing Selected Profile

Valid for option/configuration			
Model	Option no.	Option	Configuration
R100E Volvo		Engine	Tier II

Valid for serial numbers			
Model	Production site	Serial number start	Serial number stop
R100E Volvo	Motherwell	111014	119999

	kg (approx.)	lb
Total Operating Weight (loaded)	164550	362770
Net Vehicle Weight	69550	153332
Engine, complete (dry weight)	3045	6713
Transmission (dry weight)	1714	3779
Front axle and suspension (dry weight)	5395	11894
Rear axle (dry weight)	10550	23259

	Front Axle	Rear Axle
Weight Distribution (empty) %	47.4	52.6
Weight Distribution (loaded) %	33.2	66.8

Assemblies removed for transportation		
	kg (approx)	lbs
Cab	1100	2425
Dump body	16200	35715
Hand rail 1	14.6	32.2
Hand rail 2	14.2	31.3
Left-hand platform	138.7	305.8
Rock ejector	33.6	74.1
Wheel (each)	2000	4409

Dump body options		
Ensure that the GVW of the machine is not exceed when these options are fitted.		
	kg (approx)	lbs
Canopy right-hand	58.5	129
Coal body	16350.4	36046.5
Side extension 350 mm	927	2044
Side extension 150 mm	575	1268

Sample manual. Download All 3295 pages at:

<https://www.arepairmanual.com/downloads/r100e-volvo-rigid-haulers-service-manual/>