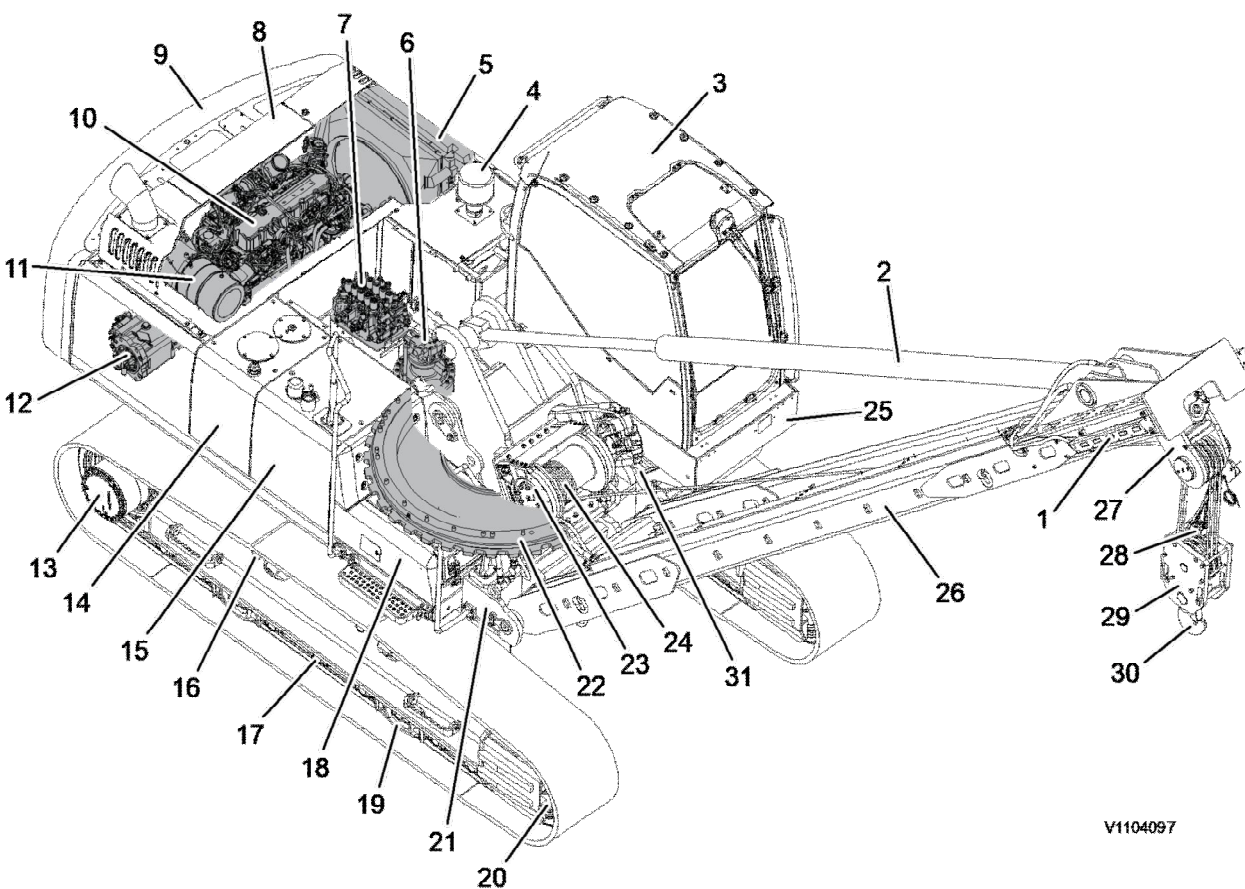


Document Title: <b>Machine view</b>	Function Group: <b>000</b>	Information Type: <b>Service Information</b>	Date: <b>4/24/2026</b>
Profile: <b>PL3005D Volvo</b>			

## Machine view

Showing Selected Profile

Valid for serial numbers			
Model	Production site	Serial number start	Serial number stop
PL3005D Volvo			



V1104097

**Figure 1**

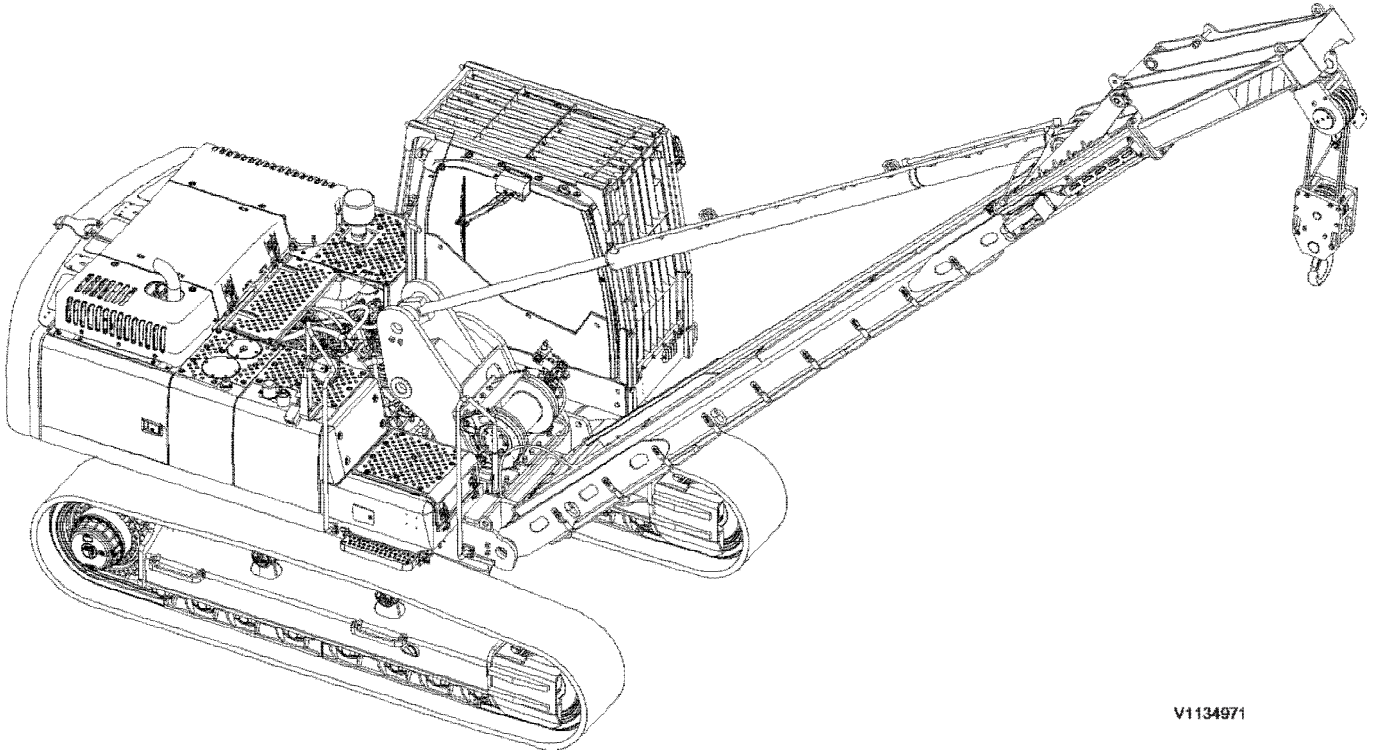
Component position

1	Light bar	17	Bottom roller
2	Boom cylinder	18	Battery
3	Operator cab	19	Track guard
4	Air cleaner	20	Idler
5	Radiator and charged air cooler	21	Adapter
6	Swing motor and gearbox	22	Swing ring gear
7	Main control valve	23	Winch and motor
8	Engine hood	24	Wire rope

Product: PL3005D Volvo Pipelayers Service Manual

Full Download: <https://www.aresrepairmanual.com/downloads/pl3005d-volvo-pipelayers-service-manual/>

9	Counterweight	25	Elevating cab structure
10	Engine	26	Boom
11	Diesel Particulate Filter (DPF)	27	Flag block
12	Main pump	28	Anti-two block switch
13	Track motor and gearbox	29	Load block
14	Hydraulic tank	30	Lifting hook
15	Fuel tank	31	Swing lock system
16	Top roller		



V1134971

**Figure 2**  
Component position

Document Title: <b>Product plates</b>	Function Group: <b>000</b>	Information Type: <b>Service Information</b>	Date: <b>4/24/2026</b>
Profile: <b>PL3005D Volvo</b>			

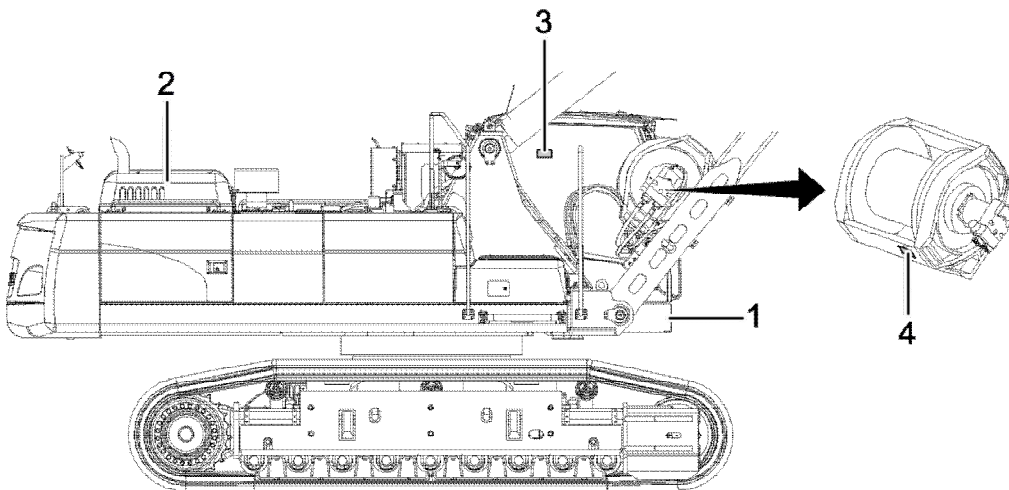
## Product plates

Showing Selected Profile

Valid for serial numbers			
Model	Production site	Serial number start	Serial number stop
PL3005D Volvo			

Please refer to the figure below to locate the machine product plate (1), engine product plate, cab product plate (3) and winch product plate (4).

Always use the Product Identification Number (PIN) provided on the vehicle and/or engine plates for troubleshooting purposes and/or when ordering spare parts.



V1070120

### Figure 1

Product plate

#### Machine product plate

This plate with Product Identification Number, PIN, for the complete machine indicates the model designation, serial number and when applicable, machine weight, engine power, manufacturing year and CE approval. The plate is positioned on the right side of the upper frame.

#### Engine product plate

The engine product plate contains type designation, part and serial numbers. It is positioned on the engine inside the rear engine cover on the right side of the machine.

#### Winch product plate

The winch product plate is located on the face of the tie bar on the winch and indicates the product model and serial number.

#### Cab product plate

The cab product plate is attached on the inside of the cab and indicates the product number, serial number, model type, and weight.

Document Title: <b>Volvo standard tightening torques</b>	Function Group: <b>030</b>	Information Type: <b>Service Information</b>	Date: <b>4/24/2026</b>
Profile: <b>PL3005D Volvo</b>			

## Volvo standard tightening torques

Showing Selected Profile

Valid for serial numbers			
Model	Production site	Serial number start	Serial number stop
PL3005D Volvo			

The tightening torques in the following tables apply to bolts and nuts with tensile strength. The tables should be used as a general instruction for tightening bolts and nuts without specified values. The charts contains values for course thread bolts and nuts.

Torque values should be increased with  $\approx 10\%$ , for flange bolts.

All standard torques for bolts are without surface treatment.

The standard torque for bolts lubricated with oil should be reduced with 20% of the given value.

### Standard tightening torque charts

Bolt size Metric Coarse Threads	Tensile strength 8.8		Tensile strength 10.9	
	(Nm)	(lbf ft)	(Nm)	(lbf ft)
M5	6	4	8	6
M6	10	7	14	11
M8	25	18	35	26
M10	50	37	70	52
M12	87	64	122	90
M14	139	103	195	144
M16	213	157	299	220
M18	293	216	413	305
M20	416	307	585	432
M24	719	530	1010	745
M27	1060	782	1490	1100
M30	1140	840	2025	1493
M36	2500	1844	3600	2653

Bolt size Inch SAE Coarse Threads	Tensile strength 5		Tensile strength 8	
	(lbf ft)	(Nm)	(lbf ft)	(Nm)
1/4	10	13,6	14	19
5/16	21	28,5	29	39,3
3/8	37	50,2	52	70
7/16	59	80	84	114
1/2	90	122	128	174
9/16	130	176	184	250
5/8	180	244	254	345

3/4	320	434	451	612
7/8	515	700	728	988
1	775	1052	1091	1480
1 1/8	953	1290	1545	2100
1 1/4	1344	1823	2180	2960
1 3/8	1600	2170	2650	3600
1 1/2	2000	2714	3200	4340

### Hydraulic connections, general

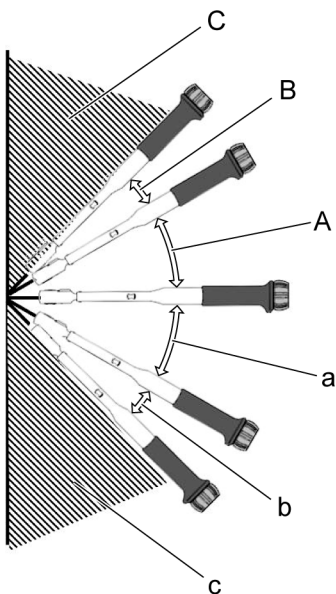
Before fitting pipe couplings, plugs and hoses:

- Make sure that the sealing surfaces are clean and free from pores or scratches.
- Check elastic seal rings for defects.
- Oil in threads, sealing surfaces and contact surfaces except for ORFS-connections (ORFS = O-Ring Face Seal).

### Applying Torque correction factor by tool angle

Tool angle	Correction factor	
	ORFS	Stud-end
Allowable tolerance	$\pm 10\%$	- 0%, +10%
$\pm 0^\circ \sim \pm 30^\circ$	5% over torque	
$\pm 30^\circ \sim \pm 45^\circ$	20% over torque	
$\pm 45^\circ$	NOT allowable	

### Tool access angle



V1223202

**Figure 1**

Tool access angle

A:  $+0^\circ \sim +30^\circ$

B:  $+30^\circ \sim +45^\circ$

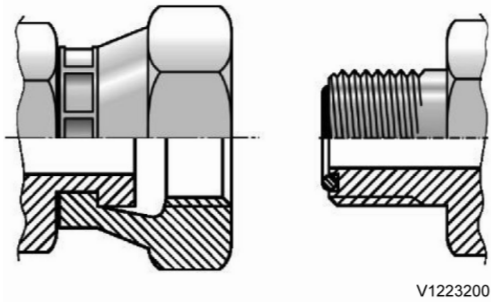
C: +45°

a: -0° ~ -30°

b: -30° ~ -45°

c: -45°

**ORFS female swivel fitting**

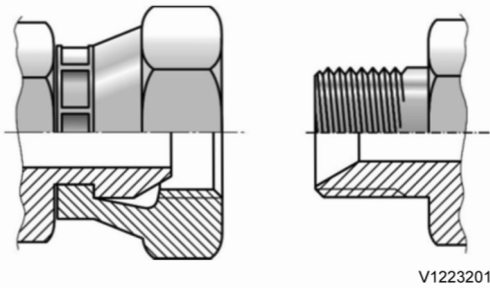


**Figure 2**

Thread s type	Assembl y position	Threads	Standard torque		±0° ~ ±30°		±30° ~ ±45°	
			(Nm)	(lbf ft)	(Nm)	(lbf ft)	(Nm)	(lbf ft)
UN- UNF	ORFS	UNF 9/16-18	29 ±3	21.4 ±2.2	30.5 ±3.1	22.1 ±2.2	36.5 ±3.7	26.9 ±2.7
		UN 11/16-16	44 ±4	32.5 ±3.0	46.2 ±4.6	34.1 ±3.4	55.4 ±5.5	40.9 ±4.1
		UN 13/16-16	63 ±6	46.5 ±4.4	66.2 ±6.6	48.8 ±4.9	79.4 ±7.9	58.6 ±5.9
		UNS 1-14	106 ±8	78.2 ±5.9	111.3 ±11.1	82.1 ±8.2	133.6 ±13.4	98.5 ±9.9
		UN 1 3/16-12	140 ±12	103.3 ±8.9	147.0 ±14.7	108.4 ±10.8	176.4 ±17.6	130.1 ±13.0
		UN 1 7/16-12	175 ±15	129.1 ±11.1	183.8 ±18.4	135.6 ±13.6	220.5 ±22.1	162.6 ±16.3
		UN 1 11/16-12	270 ±20	199.1 ±14.8	283.5 ±28.4	209.1 ±20.9	340.2 ±34.0	250.9 ±25.1
	Stud-end	UNF 7/16-20	21 +2.1	15.4 +1.5	22.1 +2.2	16.3 +1.6	26.5 +2.7	19.5 +2.0
		UNF 1/2-20	37 +3.7	27.3 +2.7	38.9 +3.9	28.7 +2.9	46.6 +4.7	34.4 +3.4
		UNF 9/16-18	47 +4.7	34.7 +3.5	49.4 +4.9	36.4 +3.6	59.2 +5.9	43.7 +4.4
		UNF 3/4-16	81 +8.1	59.7 +6.0	85.1 +8.5	62.8 +6.3	102.1 +10.2	75.3 +7.5
		UNF 7/8-14	141 +14.1	104.0 +10.4	148.1 +14.8	109.2 +10.9	177.7 +17.8	131.1 +13.1
		UN 1 1/16-12	189 +18.9	139.4 +13.9	198.5 +19.9	146.4 +14.6	238.1 +23.8	175.6 +17.6
		UN 1 5/16-12	284 +28.4	209.5 +21.0	298.2 +29.8	219.9 +22.0	357.8 +35.8	263.9 +26.4
UN 1 5/8-12	347 +34.7	255.9 +25.6	364.4 +36.4	268.8 +26.9	437.2 43.7	322.5 +32.3		

UN 1 7/8-12	425 +42.5	313.5 +31.4	446.3 +44.6	329.2 +32.9	535.5 +53.6	395.0 +39.5
----------------	-----------	-------------	-------------	-------------	-------------	-------------

**G thread 30° cone female swivel fitting**



**Figure 3**

Thread s type	Assembl y position	Threads	Standard torque		±0° ~ ±30°		±30° ~ ±45°	
			(Nm)	(lbf ft)	(Nm)	(lbf ft)	(Nm)	(lbf ft)
PF	ORFS	G 1/4-19	25 ±2.5	18.4 ±1.8	26.3 ± 2.6	19.4 ±1.9	31.5 ±3.2	23.2 ±2.3
		G 3/8-19	49 ±4.9	36.1 ±3.6	51.5 ± 5.2	38.0 ±3.8	61.7 ±6.2	45.5 ±4.6
		G 1/2-14	59 ±5.9	43.5 ±4.4	62.0 ± 6.2	45.7 ±4.6	74.3 ±7.4	54.8 ±5.5
		G 3/4-11	119 ±11.9	87.8 ±8.8	125.0 ±12.5	92.2 ±9.2	149.9 ±15.0	110.6 ±11.1
		G 1-11	140 ±14	103.3 ±10.3	147.0 ±14.7	108.4 ±10.8	176.4 ±17.6	130.1 ±13.0
		G 1 1/4-11	173 ±17.3	127.6 ±12.8	181.7 ±18.2	134.0 ±13.4	218.0 ±21.8	160.8 ±16.1
		G 1 1/2-11	205 ±20.5	151.2 ±15.1	215.3 ±21.5	158.8 ±15.9	258.3 ±25.8	190.5 ±19.1
	Stud-end	G 1/8-19	22 +2.2	16.2 +1.6	23.1 +2.3	17.0 +1.7	27.7 +2.8	20.4 +2.0
		G 1/4-19	52 +5.2	38.4 +3.8	54.6 +5.5	40.3 +4.0	65.5 +6.6	48.3 +4.8
		G 3/8-19	85 +8.5	62.7 +6.3	89.3 +8.9	65.9 +6.6	107.1 +10.7	79.0 +7.9
		G 1/2-14	105 +10.5	77.4 +7.7	110.3 +11.0	81.4 +8.1	132.3 +13.2	97.6 +9.8
		G 3/4-11	210 +21	154.9 +15.5	220.5 +22.1	162.6 +16.3	264.6 +26.5	195.2 +19.5
		G 1-11	400 +40	295.0 +29.5	420.0 +42.0	309.8 +31.0	504.0 +50.4	371.7 +37.1
		G 1 1/4-11	525 +52.5	387.2 +38.7	551.3 +55.1	406.6 +40.7	661.5 +66.2	487.9 +48.8
G 1 1/2-11	630 +63.1	464.7 +46.5	661.5 +66.2	487.9 +48.8	793.8 +79.4	585.5 +58.6		

Document Title: <b>Measurement conversion tables</b>	Function Group: <b>030</b>	Information Type: <b>Service Information</b>	Date: <b>4/24/2026</b>
Profile: <b>PL3005D Volvo</b>			

## Measurement conversion tables

Showing Selected Profile

Valid for serial numbers			
Model	Production site	Serial number start	Serial number stop
PL3005D Volvo			

### Length

Unit	cm	m	km	in	ft	yd	mile
cm	1	0.01	0.00001	0.3937	0.03281	0.01094	0.000006
m	100	1	0.001	39.37	3.2808	1.0936	0.00062
km	100000	1000	1	39370.7	3280.8	1093.6	0.62137
in	2.54	0.0254	0.000025	1	0.08333	0.02777	0.000015
ft	30.48	0.3048	0.000304	12	1	0.3333	0.000189
yd	91.44	0.9144	0.000914	36	3	1	0.000568
mile	160930	1609.3	1.6093	63360	5280	1760	1

1 mm = 0.1 cm, 1 mm = 0.001 m

### Area

Unit	cm <sup>2</sup>	m <sup>2</sup>	km <sup>2</sup>	a	ft <sup>2</sup>	yd <sup>2</sup>	in <sup>2</sup>
cm <sup>2</sup>	1	0.0001	-	0.000001	0.001076	0.000012	0.155000
m <sup>2</sup>	10000	1	0.000001	0.01	10.764	1.1958	1550.000
km <sup>2</sup>	-	1000000	1	10000	1076400	1195800	-
a	0.01	100	0.0001	1	1076.4	119.58	-
ft <sup>2</sup>	-	0.092903	-	0.000929	1	0.1111	144.000
yd <sup>2</sup>	-	0.83613	-	0.008361	9	1	1296.00
in <sup>2</sup>	6.4516	0.000645	-	-	0.006943	0.000771	1

1 ha = 100 a, 1 mile<sup>2</sup> = 259 ha = 2.59 km<sup>2</sup>

### Volume

Unit	cm <sup>3</sup> = cc	m <sup>3</sup>	Liter	in <sup>3</sup>	ft <sup>3</sup>	yd <sup>3</sup>
cm <sup>3</sup> = m liter	1	0.000001	0.001	0.061024	0.000035	0.000001
m <sup>3</sup>	1000000	1	1000	61024	35.315	1.30796
Liter	1000	0.001	1	61.024	0.035315	0.001308
in <sup>3</sup>	16.387	0.000016	0.01638	1	0.000578	0.000021
ft <sup>3</sup>	28316.8	0.028317	28.317	1728	1	0.03704
yd <sup>3</sup>	764529.8	0.76453	764.53	46656	27	1

1 gal(US) = 3785.41 cm<sup>3</sup> = 231 in<sup>3</sup> = 0.83267 gal(UK)

## Weight

Unit	g	kg	t	oz	lb
g	1	0.001	0.000001	0.03527	0.0022
kg	1000	1	0.001	35.273	2.20459
t	1000000	1000	1	35273	2204.59
oz	28.3495	0.02835	0.000028	1	0.0625
lb	453.592	0.45359	0.000454	16	1

1 tonne(metric) = 1.1023 ton(US) = 0.9842 ton(UK)

## Pressure

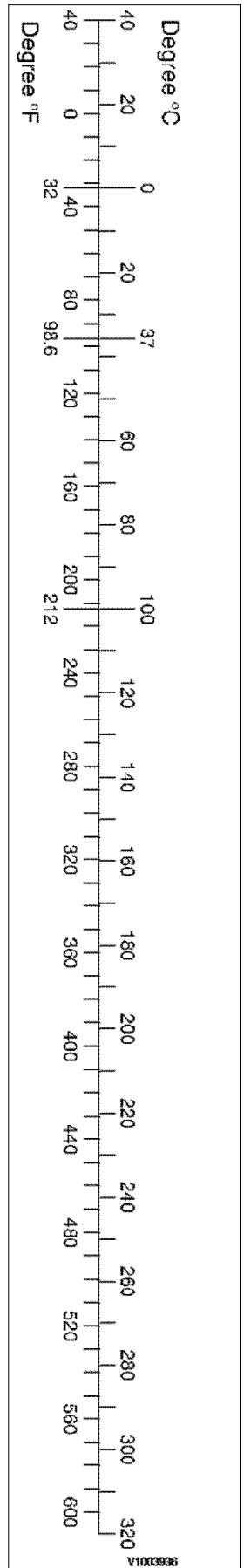
Unit	kgf/cm <sup>2</sup>	bar	Pa=N/m <sup>2</sup>	kPa	lbf/in <sup>2</sup>	lbf/ft <sup>2</sup>
kgf/cm <sup>2</sup>	1	0.98067	98066.5	98.0665	14.2233	2048.16
bar	1.01972	1	100000	100	14.5037	2088.6
Pa=N/m <sup>2</sup>	0.00001	0.001	1	0.001	0.00015	0.02086
kPa	0.01020	0.01	1000	1	0.14504	20.886
lbf/in <sup>2</sup>	0.07032	0.0689	6894.76	6.89476	1	144
lbf/ft <sup>2</sup>	0.00047	0.00047	47.88028	0.04788	0.00694	1

1 kgf/cm<sup>2</sup> = 735.56 Torr(mmHg) = 0.96784 atm

## Approximate conversions

SI	Conversion	Non-SI	Conversion	SI
Unit	Factor	Unit	Factor	Unit
<b>Torque</b>				
newton meter (N·m)	x 10.2	= kgf·cm	x 0.8664	= (lbf·in)
newton meter (N·m)	x 0.74	= lb·ft	x 1.36	= N·m
newton meter (N·m)	x 0.102	= kgf·m	x 7.22	= (lbf·ft)
<b>Pressure (Pa = N/m<sup>2</sup>)</b>				
kilopascal (kPa)	x 4.0	= in. H <sub>2</sub> O	x 0.249	= kPa
kilopascal (kPa)	x 0.30	= in. Hg	x 3.38	= kPa
kilopascal (kPa)	x 0.145	= psi	x 6.89	= kPa
(bar)	x 14.5	= psi	x 0.069	= (bar)
(kgf/cm <sup>2</sup> )	x 14.22	= psi	x 0.070	= (kgf/cm <sup>2</sup> )
(newton/mm <sup>2</sup> )	x 145.04	= psi	x 0.069	= (bar)
megapascal (MPa)	x 145	= psi	x 0.00689	= MPa
<b>Power (W = J/s)</b>				
kilowatt (kW)	x 1.36	= PS (cv)	x 0.736	= kW
kilowatt (kW)	x 1.34	= HP	x 0.746	= kW
kilowatt (kW)	x 0.948	= Btu/s	x 1.055	= kW
watt (W)	x 0.74	= ft·lb/s	x 1.36	= W

Note: ( ) non-si unit



**Approximate conversions**

SI Unit	Conversion Factor	Non-SI Unit	Conversion Factor	SI Unit



Document Title: <b>Thermostat, specifications</b>	Function Group: <b>030</b>	Information Type: <b>Service Information</b>	Date: <b>4/24/2026</b>
Profile: <b>PL3005D Volvo</b>			

## Thermostat, specifications

Showing Selected Profile

Valid for option/configuration			
Model	Option no.	Option	Configuration
PL3005D Volvo	8291930	Engine	D7E Engine for BRIC (Tier 3)

Valid for serial numbers			
Model	Production site	Serial number start	Serial number stop
PL3005D Volvo	Changwon	280001	310000

Thermostat, type	Piston thermostat
Quantity	1
Coolant thermostat begins to open at	83 °C (181 °F)
Coolant thermostat fully open at	95 °C (302 °F)
Coolant thermostat stroke distance	8 mm (0.32 in)

Document Title: <b>Operation numbers for additional work</b>	Function Group: <b>070</b>	Information Type: <b>Service Information</b>	Date: <b>4/24/2026</b>
Profile: <b>Pipelayers (PIP)</b>			

## Operation numbers for additional work

Showing Selected Profile

These operations can be used to identify work that is not included in the time guide or described in the methods in the Service Manual. When these operations are used, a description of the work that has been performed must be provided.

### Other work related to engine

Op. no. 070-210

This operation can be used when work has been done related to the engine and function group 2 when no applicable method description was available. When this operation is used, additional information is required:

- Description of work that has been done

### Other work related to electrical system

Op. no. 070-310

This operation can be used when work has been done related to the electrical system and function group 3 when no applicable method description was available. When this operation is used, additional information is required:

- Description of work that has been done

### Other work related to transmission, gearbox, travel motor, swing motor

Op. no. 070-410

This operation can be used when work has been done related to the transmission, gearbox, travel motor or swing motor and function group 4 when no applicable method description was available. When this operation is used, additional information is required:

- Description of work that has been done

### Other work related to drive axle

Op. no. 070-470

This operation can be used when work has been done related to the drive axle and function group 46 when no applicable method description was available. When this operation is used, additional information is required:

- Description of required work that have been done

### Other work related to brake system

Op. no. 070-510

This operation can be used when work has been done related to the brake system and function group 5 when no applicable

method description was available. When this operation is used, additional information is required:

- Description of work that has been done

**Other work related to steering system**

Op. no. 070-610

This operation can be used when work has been done related to the steering system and function group 6 when no applicable method description was available. When this operation is used, additional information is required:

- Description of work that has been done

**Other work related to frame link, axle suspension**

Op. no. 070-710

This operation can be used when work has been done related to the frame link, axle suspension and other parts related to function group 7 when no applicable method description was available. When this operation is used, additional information is required:

- Description of work that has been done

**Other work related to cab, air conditioning**

Op. no. 070-810

This operation can be used when work has been done related to the cab, air conditioning and other parts related to function group 8 when no applicable method description was available. When this operation is used, additional information is required:

- Description of work that has been done

**Other work related to hydraulic system**

Op. no. 070-910

This operation can be used when work has been done related to the hydraulic system and other parts related to function group 9 when no applicable method description was available. When this operation is used, additional information is required:

- Description of work that has been done

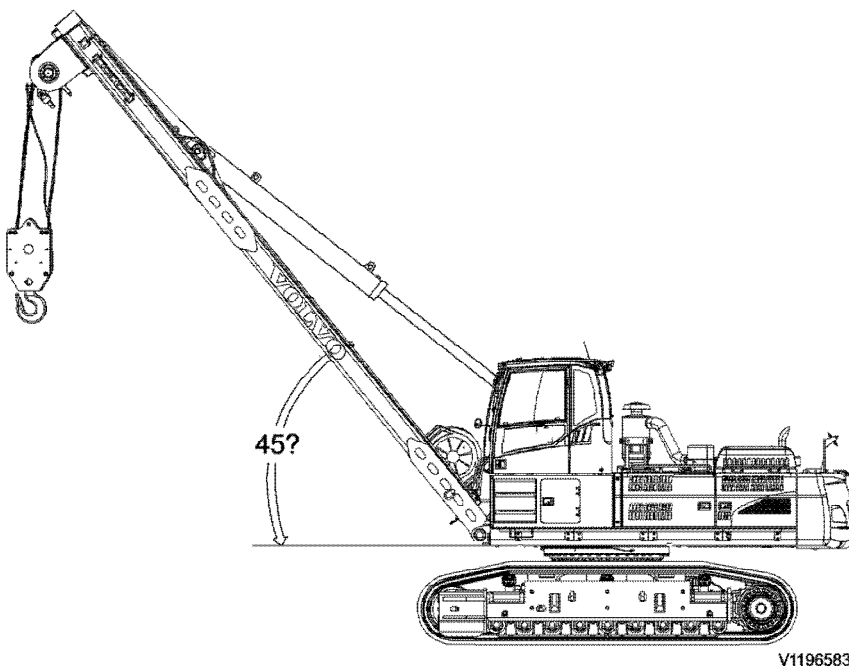
Document Title: <b>Service positions</b>	Function Group: <b>091</b>	Information Type: <b>Service Information</b>	Date: <b>4/24/2026</b>
Profile: <b>PL3005D Volvo</b>			

### Service positions

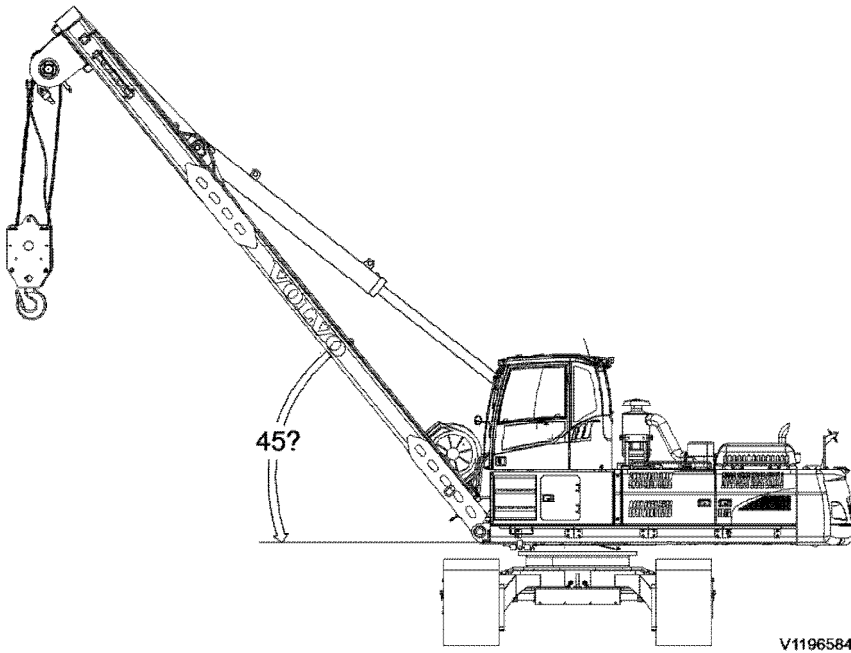
Showing Selected Profile

Valid for serial numbers			
Model	Production site	Serial number start	Serial number stop
PL3005D Volvo			

Park the machine on a horizontal and firm surface.  
The suitable position is indicated in the description for the various service jobs.

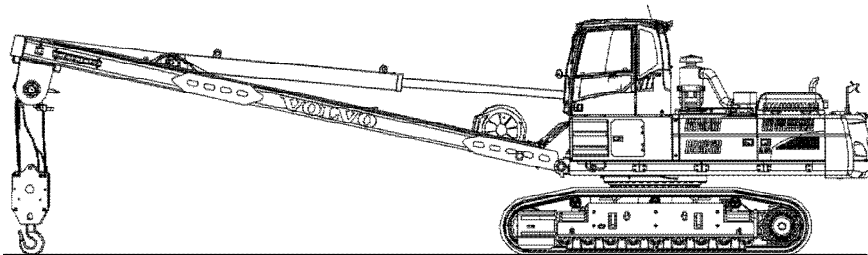


**Figure 1**  
Service position A



V1196584

**Figure 2**  
Service position B



V1196585

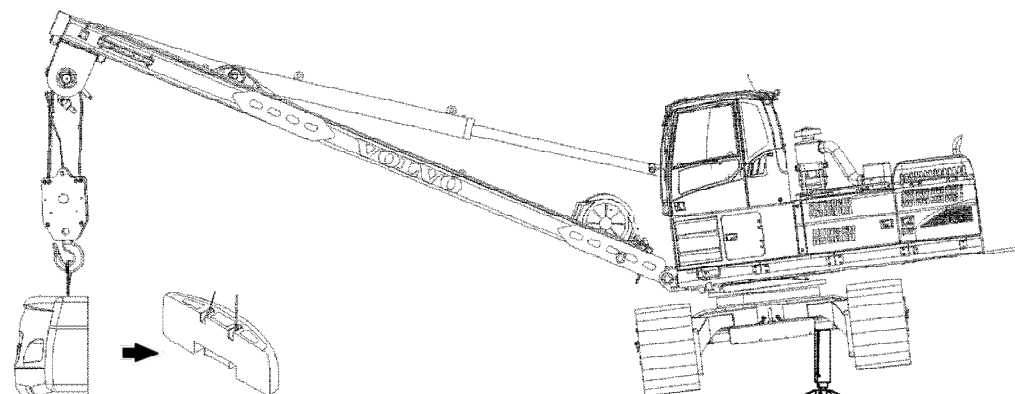
**Figure 3**  
Service position C

**Tools**

– 2 x 10,000 kg (22046 lbs) jacks and block.

Remove the counterweight. See [Counterweight, removing](#).

- A. Cab in lowered position
- B. Anchor rear of machine with strap or chain to prevent accidental tip over. (in counterweight)
- C. Counterweight
- D. Block front of machine to prevent track from slipping
- E. Boom angle below 45°. (boom less than 45°)

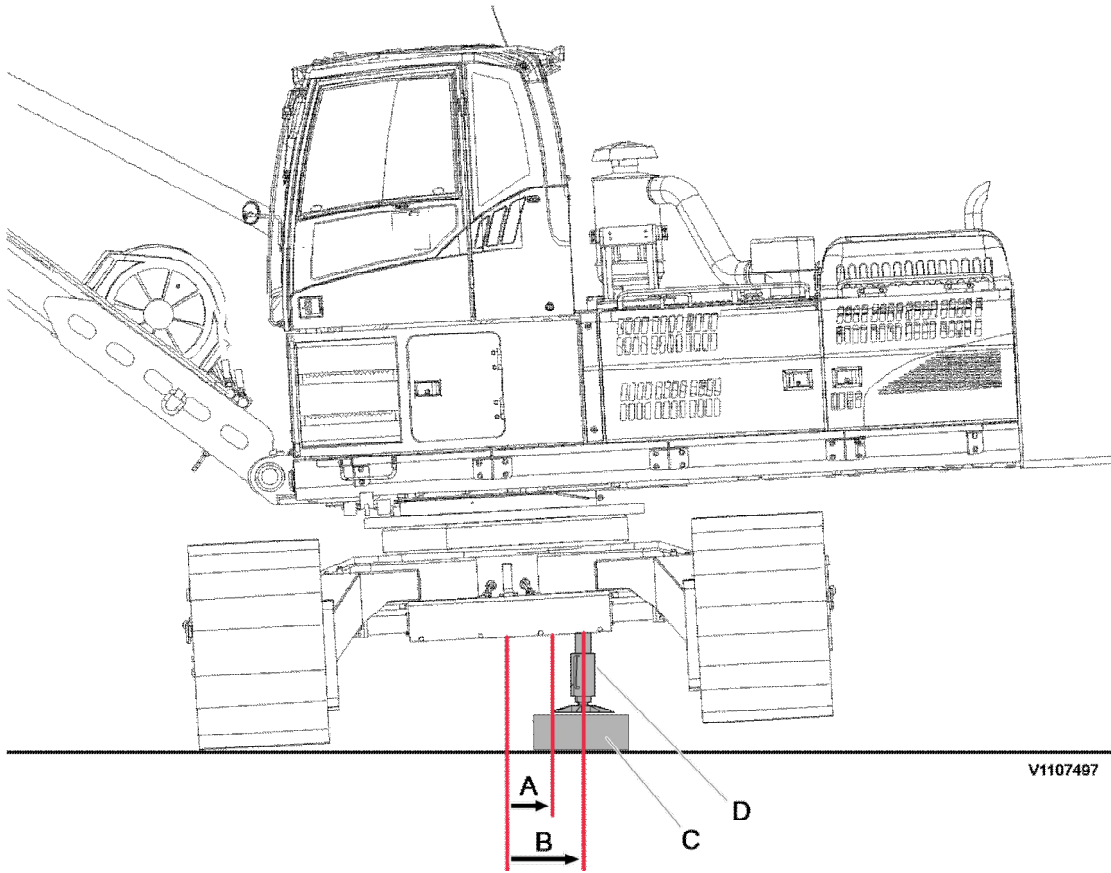


V1196586

**Figure 4**

Service position D

- Lift one side of machine using 2 x 10,000 kg (22046 lbs) jacks.
- Position the jacks 450 mm (A) - 650 mm (B) from the center of the machine.
- Slowly lift machine until track (D) is off the ground. (C: block)
- Service rollers, track guard and others as needed.
- Slowly lower machine and return machine to normal operating condition.
- Install the counterweight. See [Counterweight installation](#).



**Figure 5**

Service position D

Document Title: <b>Welding on the machine</b>	Function Group: <b>091</b>	Information Type: <b>Service Information</b>	Date: <b>4/24/2026</b>
Profile: <b>PL3005D Volvo</b>			

## Welding on the machine

Showing Selected Profile

Valid for serial numbers			
Model	Production site	Serial number start	Serial number stop
PL3005D Volvo			

### NOTICE

**During electric welding on the machine or attachments connected to the machine, components such as bearings and electric units may be damaged if the ground cable is connected incorrectly.**

The following actions should be taken before starting electric welding to eliminate these risks:

1. Turn off the electric power using the battery disconnecter.
2. Disconnect the batteries.  
**NOTE!**  
Both the plus and minus terminal.
3. Disconnect the following electronic units:
  - Vehicle electronic control unit (V-ECU)
  - Engine electronic control unit (E-ECU)
  - Instrument electronic control unit (I-ECU)
  - Electronic climate control unit (ECC)
  - Wiper control unit (CU3601)
4. Connect the welding unit's ground connection as close as possible to the welding point, and make sure that the current does not pass across a bearing.

If welding is necessary on the boom or dipper arm, the following basic rules should be followed:

1. Welding beads should be laid down in the longitudinal direction.
2. If possible, weld in the middle of the metal section and never closer than **80 mm** to an edge.
3. Do not weld near the welded connections of the cylinder mounting eyes. Minimum distance from eye's weld to weld for weld lug = **100 mm**.
4. Do not weld close to where a metal plate has been bent.

Document Title: <b>Hydraulic cylinders, dieseling</b>	Function Group: <b>091</b>	Information Type: <b>Service Information</b>	Date: <b>4/24/2026</b>
Profile: <b>PL3005D Volvo, PL3005D Volvo</b>			

## Hydraulic cylinders, dieseling

Showing Selected Profile

Valid for serial numbers			
Model	Production site	Serial number start	Serial number stop
PL3005D Volvo			
PL3005D Volvo			

If air enters the hydraulic cylinders during work on the hydraulic system, this can lead to spontaneous ignition, an effect known as dieseling. This occurs if a favourable mixture of air and hydraulic oil is compressed when the piston approaches its end position in the cylinder. A sufficiently high temperature can be reached for the mixture to spontaneously ignite.

### NOTICE

**The dieseling effect may result in burnt piston seals and bushings.**

In order to prevent dieseling, the lines for the hydraulic cylinders must be bled after work is completed, as follows:

1. No load and keep the lowest engine rpm
2. Operate the piston slowly up to the middle of cylinder in order to remove air from inner chamber of cylinder. Repeat over 5 times.  
After that, operate the piston up to the end of cylinder in order to remove residual air from cylinder, pipe and hose gradually. Repeat over 5 times.

### NOTICE

**If the cylinders are pressurized either through lifting of the machine or lifting of a load in the bucket, without first performing the mentioned bleeding movements, the seals will likely be damaged.**

If a cylinder is to be pressure-tested after a repair, the piston rod should be run in and out a few times before increasing the pressure to testing pressure.

Document Title: <b>Recommended lubricants</b>	Function Group: <b>160</b>	Information Type: <b>Service Information</b>	Date: <b>4/24/2026</b>
Profile: <b>PL3005D Volvo</b>			

[Go back to Index Page](#)

## Recommended lubricants

Showing Selected Profile

Valid for serial numbers			
Model	Production site	Serial number start	Serial number stop
PL3005D Volvo			

The Volvo lubricants have been specially developed to fulfil the demanding operating conditions, in which Volvo pipelayers are used in. The oils have been tested according to Volvo pipelayer specifications and therefore meet the high requirements for safety and quality.

Other mineral oils can be used if they conform to our viscosity recommendations and meet our quality requirements. The approval of Volvo is required, if any other oil base quality (for example biologically degradable oil) is to be used.

System	Oil grade	Recommended viscosity at varying ambient temperature									
		°C	-30	-20	-10	0	+10	+20	+30	+40	+50
		°F	-22	-4	+14	+32	+50	+68	+86	+104	+122
Engine	Engine oil see page <a href="#">Engine oil</a> .					SAE 10W-30***					
						*SAE 15W-40					
						SAE 10W-40					
						SAE 5W-30***					
						SAE 5W-40					
Track gearbox	Gear oil (with EP** additive) API GL4 or GL5					*SAE 90			SAE 140		
Swing gearbox	Gear oil (with EP** additive) API GL4 or GL5					*SAE 90			SAE 140		
Swing ring gear (Bath and ball)	Grease					Multi purpose EP** grease NLGI 2					
		°C	-30	-20	-10	0	+10	+20	+30	+40	+50
		°F	-22	-4	+14	+32	+50	+68	+86	+104	+122

\*: Installed at factory

\*\* : Extreme Pressure

\*\*\*: VDS-4 or VDS-4.5 approved oils only. Other oils can be used up to +30°C (86°F).

System	Oil grade	Recommended viscosity at varying ambient temperature									
		°C	-30	-20	-10	0	+10	+20	+30	+40	+50
		°F	-22	-4	+14	+32	+50	+68	+86	+104	+122
Hydraulic system	Volvo Extra hydraulic oil					ISO VG32 HV			ISO VG46 HV		



Document Title: <b>Recommended lubricants</b>	Function Group: <b>160</b>	Information Type: <b>Service Information</b>	Date: <b>4/24/2026</b>
Profile: <b>PL3005D Volvo</b>			

[Go back to Index Page](#)

## Recommended lubricants

Showing Selected Profile

Valid for serial numbers			
Model	Production site	Serial number start	Serial number stop
PL3005D Volvo			

The Volvo lubricants have been specially developed to fulfil the demanding operating conditions, in which Volvo excavators are used in. The oils have been tested according to Volvo excavator specifications and therefore meet the high requirements for safety and quality. Other mineral oils can be used if they conform to our viscosity recommendations and meet our quality requirements. The approval of Volvo is required, if any other oil base quality (for example biologically degradable oil) is to be used.

### NOTE!

If a high water or excessive contamination in the lubricants (e.g. engine oil, hydraulic oil, axle oil, etc.) is found by Volvo oil analysis, change the lubricants regardless of the change interval.

See service bulletins "Oil sampling" in function group 160.

System	Oil grade	Recommended viscosity at varying ambient temperature																				
Engine	Engine oil For detail, see page <a href="#">Engine oil</a> .	<table border="1"> <tr> <td>°C</td> <td>-30</td> <td>-20</td> <td>-10</td> <td>0</td> <td>+10</td> <td>+20</td> <td>+30</td> <td>+40</td> <td>+50</td> </tr> <tr> <td>°F</td> <td>-22</td> <td>-4</td> <td>+14</td> <td>+32</td> <td>+50</td> <td>+68</td> <td>+86</td> <td>+104</td> <td>+122</td> </tr> </table>	°C	-30	-20	-10	0	+10	+20	+30	+40	+50	°F	-22	-4	+14	+32	+50	+68	+86	+104	+122
°C	-30	-20	-10	0	+10	+20	+30	+40	+50													
°F	-22	-4	+14	+32	+50	+68	+86	+104	+122													
Fuel	Diesel fuel For detail, see page <a href="#">Fuel</a> .	<table border="1"> <tr> <td>°C</td> <td>-30</td> <td>-20</td> <td>-10</td> <td>0</td> <td>+10</td> <td>+20</td> <td>+30</td> <td>+40</td> <td>+50</td> </tr> <tr> <td>°F</td> <td>-22</td> <td>-4</td> <td>+14</td> <td>+32</td> <td>+50</td> <td>+68</td> <td>+86</td> <td>+104</td> <td>+122</td> </tr> </table> <p><b>NOTE!</b> The fuel should at least meet the legal requirement, and national and international standards for marketed fuels, for example : EN590 (with nationally adapted temperature requirements), ASTM D975 No 1-D and No 2-D, JIS KK 2204.</p>	°C	-30	-20	-10	0	+10	+20	+30	+40	+50	°F	-22	-4	+14	+32	+50	+68	+86	+104	+122
°C	-30	-20	-10	0	+10	+20	+30	+40	+50													
°F	-22	-4	+14	+32	+50	+68	+86	+104	+122													
Cooling system	<b>Volvo Coolant VCS-2 Ready Mixed</b> For detail, see page <a href="#">Coolant</a> .	<b>Volvo Coolant VCS Ready Mixed</b> should be used only. <b>NOTE!</b> The content of Volvo coolant must not be less than 40% of the total mixture.																				

\*: Installed at factory

\*\*\*: VDS-4 or VDS-4.5 approved oils only. Other oils can be used up to +30°C (86°F).

System	Oil grade	Recommended viscosity at varying ambient temperature																																																	
Hydraulic system	Hydraulic oil for severe cold area or if siberian option kit is installed	<table border="1"> <tr> <td>°C</td> <td>-30</td> <td>-20</td> <td>-10</td> <td>0</td> <td>+10</td> <td>+20</td> <td>+30</td> <td>+40</td> <td>+50</td> </tr> <tr> <td>°F</td> <td>-22</td> <td>-4</td> <td>+14</td> <td>+32</td> <td>+50</td> <td>+68</td> <td>+86</td> <td>+104</td> <td>+122</td> </tr> <tr> <td colspan="10" style="text-align: center;">ISO VG15</td> </tr> </table>	°C	-30	-20	-10	0	+10	+20	+30	+40	+50	°F	-22	-4	+14	+32	+50	+68	+86	+104	+122	ISO VG15																												
	°C	-30	-20	-10	0	+10	+20	+30	+40	+50																																									
	°F	-22	-4	+14	+32	+50	+68	+86	+104	+122																																									
	ISO VG15																																																		
Volvo Hydraulic Oil 98609 Extra 32 or Volvo Hydraulic Oil 98609 Extra 46 or Volvo Hydraulic Oil 98609 Extra 68 or Volvo Hydraulic Oil 98611 HO103 32 Volvo Hydraulic Oil 98611 HO103 46 Volvo Hydraulic Oil 98611 HO103 68	<table border="1"> <tr> <td>°C</td> <td>-30</td> <td>-20</td> <td>-10</td> <td>0</td> <td>+10</td> <td>+20</td> <td>+30</td> <td>+40</td> <td>+50</td> </tr> <tr> <td>°F</td> <td>-22</td> <td>-4</td> <td>+14</td> <td>+32</td> <td>+50</td> <td>+68</td> <td>+86</td> <td>+104</td> <td>+122</td> </tr> <tr> <td colspan="10" style="text-align: center;">ISO VG32 HV</td> </tr> <tr> <td colspan="10" style="text-align: center;">ISO VG46 HV</td> </tr> <tr> <td colspan="10" style="text-align: center;">ISO VG68 HV</td> </tr> </table>	°C	-30	-20	-10	0	+10	+20	+30	+40	+50	°F	-22	-4	+14	+32	+50	+68	+86	+104	+122	ISO VG32 HV										ISO VG46 HV										ISO VG68 HV									
°C	-30	-20	-10	0	+10	+20	+30	+40	+50																																										
°F	-22	-4	+14	+32	+50	+68	+86	+104	+122																																										
ISO VG32 HV																																																			
ISO VG46 HV																																																			
ISO VG68 HV																																																			
Volvo Hydraulic Oil 98610 Biodegradable 46	<table border="1"> <tr> <td>°C</td> <td>-30</td> <td>-20</td> <td>-10</td> <td>0</td> <td>+10</td> <td>+20</td> <td>+30</td> <td>+40</td> <td>+50</td> </tr> <tr> <td>°F</td> <td>-22</td> <td>-4</td> <td>+14</td> <td>+32</td> <td>+50</td> <td>+68</td> <td>+86</td> <td>+104</td> <td>+122</td> </tr> <tr> <td colspan="10" style="text-align: center;">Bio oil VG46</td> </tr> </table> <p><b>NOTE!</b> If the machine is filled with Volvo Biodegradable hydraulic oil this oil must also be used when filling and changing. The mineral oil content in bio oil should not exceed 2% when changing from mineral oil to bio oil. Contact a workshop authorised by Volvo.</p>	°C	-30	-20	-10	0	+10	+20	+30	+40	+50	°F	-22	-4	+14	+32	+50	+68	+86	+104	+122	Bio oil VG46																													
°C	-30	-20	-10	0	+10	+20	+30	+40	+50																																										
°F	-22	-4	+14	+32	+50	+68	+86	+104	+122																																										
Bio oil VG46																																																			
Volvo Hydraulic Oil 98620 Ultra 32 or Volvo Hydraulic Oil 98620 Ultra 46 or Volvo Hydraulic Oil 98620 Ultra 68	<table border="1"> <tr> <td>°C</td> <td>-30</td> <td>-20</td> <td>-10</td> <td>0</td> <td>+10</td> <td>+20</td> <td>+30</td> <td>+40</td> <td>+50</td> </tr> <tr> <td>°F</td> <td>-22</td> <td>-4</td> <td>+14</td> <td>+32</td> <td>+50</td> <td>+68</td> <td>+86</td> <td>+104</td> <td>+122</td> </tr> <tr> <td colspan="10" style="text-align: center;">ISO VG32</td> </tr> <tr> <td colspan="10" style="text-align: center;">ISO VG46</td> </tr> <tr> <td colspan="10" style="text-align: center;">ISO VG68</td> </tr> </table>	°C	-30	-20	-10	0	+10	+20	+30	+40	+50	°F	-22	-4	+14	+32	+50	+68	+86	+104	+122	ISO VG32										ISO VG46										ISO VG68									
°C	-30	-20	-10	0	+10	+20	+30	+40	+50																																										
°F	-22	-4	+14	+32	+50	+68	+86	+104	+122																																										
ISO VG32																																																			
ISO VG46																																																			
ISO VG68																																																			

System	Oil grade	Recommended viscosity at varying ambient temperature																																								
Track gearbox	Volvo Axle Oil 97321 80W-90 or	<table border="1"> <tr> <td>°C</td> <td>-30</td> <td>-20</td> <td>-10</td> <td>0</td> <td>+10</td> <td>+20</td> <td>+30</td> <td>+40</td> <td>+50</td> </tr> <tr> <td>°F</td> <td>-22</td> <td>-4</td> <td>+14</td> <td>+32</td> <td>+50</td> <td>+68</td> <td>+86</td> <td>+104</td> <td>+122</td> </tr> <tr> <td colspan="10" style="text-align: center;">*SAE 90</td> </tr> <tr> <td colspan="10" style="text-align: center;">SAE 140</td> </tr> </table>	°C	-30	-20	-10	0	+10	+20	+30	+40	+50	°F	-22	-4	+14	+32	+50	+68	+86	+104	+122	*SAE 90										SAE 140									
°C	-30		-20	-10	0	+10	+20	+30	+40	+50																																
°F	-22	-4	+14	+32	+50	+68	+86	+104	+122																																	
*SAE 90																																										
SAE 140																																										
Swing gearbox	Volvo Axle Oil 97321 80W-140 or																																									
PTO gearbox (EC950 only)	Volvo Axle Oil 97317 75W-80 GO102 or Volvo Synthetic Axle Oil 97312 75W-90 or Volvo Axle Oil 97321 85W-90 Limited Slip	Or corresponding gearbox oil below.  <input type="radio"/> Mobil SHC630 <input type="radio"/> Volvo Synthetic Drum Eccentric Oil																																								
Swing ring gear (Bath and Ball)	Volvo Multipurpose Grease 97718 GR101	<table border="1"> <tr> <td>°C</td> <td>-30</td> <td>-20</td> <td>-10</td> <td>0</td> <td>+10</td> <td>+20</td> <td>+30</td> <td>+40</td> <td>+50</td> </tr> <tr> <td>°F</td> <td>-22</td> <td>-4</td> <td>+14</td> <td>+32</td> <td>+50</td> <td>+68</td> <td>+86</td> <td>+104</td> <td>+122</td> </tr> <tr> <td colspan="10" style="text-align: center;">Multi purpose EP** grease NLGI 2</td> </tr> </table> <p>Or corresponding grease on lithium base with EP** additives and consistency NLGI class 2.</p>	°C	-30	-20	-10	0	+10	+20	+30	+40	+50	°F	-22	-4	+14	+32	+50	+68	+86	+104	+122	Multi purpose EP** grease NLGI 2																			
°C	-30	-20	-10	0	+10	+20	+30	+40	+50																																	
°F	-22	-4	+14	+32	+50	+68	+86	+104	+122																																	
Multi purpose EP** grease NLGI 2																																										
Pin and bushing	Volvo Extreme Grease 97765 GR103 or Volvo Multipurpose Grease 97718 GR101[T1] ⓘ For detail, see page <a href="#">Grease</a> .	<table border="1"> <tr> <td>°C</td> <td>-30</td> <td>-20</td> <td>-10</td> <td>0</td> <td>+10</td> <td>+20</td> <td>+30</td> <td>+40</td> <td>+50</td> </tr> <tr> <td>°F</td> <td>-22</td> <td>-4</td> <td>+14</td> <td>+32</td> <td>+50</td> <td>+68</td> <td>+86</td> <td>+104</td> <td>+122</td> </tr> <tr> <td colspan="10" style="text-align: center;">*ISO-L-XBCFB2</td> </tr> </table> <p>Or corresponding grease on lithium base with EP** additives and consistency NLGI class 2.</p>	°C	-30	-20	-10	0	+10	+20	+30	+40	+50	°F	-22	-4	+14	+32	+50	+68	+86	+104	+122	*ISO-L-XBCFB2																			
°C	-30	-20	-10	0	+10	+20	+30	+40	+50																																	
°F	-22	-4	+14	+32	+50	+68	+86	+104	+122																																	
*ISO-L-XBCFB2																																										
Air conditioner system	Refrigerant	HFC R134a																																								

[T1] Volvo Multipurpose Grease 97718 GR101 is not recommended when the ambient temperature is above 40 °C.

\*: Installed at factory  
\*\*: Extreme Pressure

Document Title: <b>Grease</b>	Function Group: <b>160</b>	Information Type: <b>Service Information</b>	Date: <b>4/24/2026</b>
Profile: <b>PL3005D Volvo</b>			

## Grease

Showing Selected Profile

Valid for serial numbers			
Model	Production site	Serial number start	Serial number stop
PL3005D Volvo			

### Recommended grease for all digging equipment greasing points

Manufacturer	Product name	
	Recommendations	Alternatives*
<b>VOLVO</b>	Volvo Extreme Grease 97765 GR103	Volvo Multipurpose Grease 97718 GR101
<b>CALTEX</b>	Molytex EP2	Multifak EP2
<b>GULF</b>	Gulflex Moly EP	Gulfcrown EP2
<b>EXXONMOBIL</b>	Beacon EP2 Moly	Beacon EP2
<b>SHELL</b>	Retinax HDX2 / Alvania HDX2	Retinax EP2 / Alvania EP2
<b>TOTAL</b>	Multis MS2	Multis EP2
<b>CASTROL</b>	Pyro LM	Pyroplex Red

\* Alternatives are not recommended when the ambient temperature is above 40 °C.

### Mixability of types of grease with different additives

	Mixability of types of grease with additives					
	Lithium	Calcium	Lithium complex	Calcium complex	Aluminium complex	Clay
<b>Lithium</b>	√	√	√			
<b>Calcium</b>	√	√	√			√
<b>Lithium complex</b>	√	√	√	√		
<b>Calcium complex</b>			√	√		
<b>Aluminium complex</b>			√		√	
<b>Clay</b>		√			√	√

√ : Acceptable

Document Title: <b>Hydraulic oil</b>	Function Group: <b>160</b>	Information Type: <b>Service Information</b>	Date: <b>4/24/2026</b>
Profile: <b>PL3005D Volvo</b>			

## Hydraulic oil

Showing Selected Profile

Valid for serial numbers			
Model	Production site	Serial number start	Serial number stop
PL3005D Volvo			

Only use Volvo genuine hydraulic oil approved by Volvo Construction Equipment. Do not mix different brands of hydraulic oil as this can lead to damage in the hydraulic system.

For the hydraulic oil specification, see page [Recommended lubricants](#).

	Ambient temperature											
	°C	-40	-30	-20	-10	0	+10	+20	+30	+40	+50	+60
	°F	-40	-22	-4	+14	+32	+50	+68	+86	+104	+122	+140
<b>Oil grade</b>		(B)			(A)			(C)				
		(B)			(A)			(C)				
		(B)			(A)							

(A) : Ambient temperature recommended for general use of hydraulic system and components.

(B) : Ambient temperature guide for machine operation from a hydraulic oil viewpoint only, it does not guarantee the completion machine for other conditions like engine starting performance. In this range a warming-up period is needed to obtain proper performance.

(C) : Ambient temperature range to operate machine under special conditions, not a recommendation for general use conditions.

### Additional recommendation for severe cold areas

A field solution for severe cold condition of ambient temperature between -40°C and +20°C.

- Type : Anti-wear type hydraulic oil
- Viscosity characteristic

Viscosity index : More than 130

Kinematic Viscosity : Less than 5,000cSt at -40°C, More than 5.6cSt at +90°C

### NOTE!

This value is approximately equivalent to ISO Viscosity grade #22.

### NOTE!

It is minimum theoretical recommendation without the guarantee of machine condition.

### NOTE!

If the machine is filled with biodegradable Volvo hydraulic oil, it is recommended to take regular oil samples. See service bulletin "Recommendations for Oil Sampling Intervals" in function group 160.

Document Title: <b>Lubricants and filling capacities</b>	Function Group: <b>160</b>	Information Type: <b>Service Information</b>	Date: <b>4/24/2026</b>
Profile: <b>PL3005D Volvo</b>			

[Go back to Index Page](#)

## Change capacities

Showing Selected Profile

Valid for option/configuration			
Model	Option no.	Option	Configuration
PL3005D Volvo	8289045	Engine	D8H Engine for US (Tier 4 i)
PL3005D Volvo	8289682	Engine	D8H Engine for EU (Tier 4 i)

Valid for serial numbers			
Model	Production site	Serial number start	Serial number stop
PL3005D Volvo	Changwon	210001	280000

Oils and other liquids	Change capacities
Engine oil, including filter	32 litres (8.5 US gal.)
Coolant	41 litres (10.8 US gal.)
Hydraulic tank	195 litres (51.5 US gal.)
Hydraulic system, total	400 litres (106 US gal.)
Swing gearbox	6 litres (1.6 US gal.)
Track gearbox (each)	6.8 litres (1.8 US gal.)
Fuel tank	470 litres (124 US gal.)
Swing ring gear	36 litres (9.5 US gal./ 32.4 kg)
Oil bath air cleaner	5.5 litres (1.45 US gal.)
Winch oil	4.7 litres ( 1.24 US gal.)

Document Title: <b>Lubricants and filling capacities</b>	Function Group: <b>160</b>	Information Type: <b>Service Information</b>	Date: <b>4/24/2026</b>
Profile: <b>PL3005D Volvo</b>			

[Go back to Index Page](#)

## Change capacities

Showing Selected Profile

Valid for option/configuration			
Model	Option no.	Option	Configuration
PL3005D Volvo	8291930	Engine	D7E Engine for BRIC (Tier 3)

Valid for serial numbers			
Model	Production site	Serial number start	Serial number stop
PL3005D Volvo	Changwon	280001	310000

Oils and other liquids	Change capacities
Engine oil, including filter	32 litres (8.5 US gal.)
Coolant	30 litres (7.9 US gal.)
Hydraulic tank	195 litres (51.5 US gal.)
Hydraulic system, total	400 litres (106 US gal.)
Swing gearbox	6 litres (1.6 US gal.)
Track gearbox (each)	6.8 litres (1.8 US gal.)
Fuel tank	470 litres (124 US gal.)
Swing ring gear	36 litres (9.5 US gal./ 32.4 kg)
Oil bath air cleaner	5.5 litres (1.45 US gal.)
Winch oil	4.7 litres ( 1.24 US gal.)

Document Title: <b>Engine oil</b>	Function Group: <b>160</b>	Information Type: <b>Service Information</b>	Date: <b>4/24/2026</b>
Profile: <b>PL3005D Volvo</b>			

## Engine oil

Showing Selected Profile

Valid for serial numbers			
Model	Production site	Serial number start	Serial number stop
PL3005D Volvo	Changwon	280001	310000

Follow recommended change intervals according to the oil's grade and sulphur content in the fuel.

Oil grade	Sulphur content in the fuel, ppm (10000 ppm = 1%)		
	< 3000	3000 - 5000	5000 - 10000
<b>Volvo Engine Oil VDS-4.5 10W-30</b> or <b>Volvo Engine Oil VDS-4.5 15W-40</b> or Other approved VDS-4.5 oil	500 hours	250 hours	125 hours
Other approved VDS-4 oil			
<b>Volvo Engine Oil VDS-3 10W-40</b> or <b>Volvo Engine Oil VDS-3 15W-40</b> or Other approved VDS-3 oil	250 hours	125 hours	75 hours
ACEA: E7 or E9			
API: CH-4 or CI-4 or CJ-4 or CK-4			

- ACEA: European Automobile Manufacturers Association
- API: American Petroleum Institute

Document Title: <b>Fuel</b>	Function Group: <b>160</b>	Information Type: <b>Service Information</b>	Date: <b>4/24/2026</b>
Profile: <b>PL3005D Volvo</b>			

[Go back to Index Page](#)

## Fuel

Showing Selected Profile

Valid for serial numbers			
Model	Production site	Serial number start	Serial number stop
PL3005D Volvo	Changwon	210001	280000

### Fuel quality requirements

The fuel should at least meet the legal requirements, national and international standards for marketed fuels, for example: EN590 (with nationally adapted temperature requirements), ASTM D 975 No. 1D and 2D, JIS KK 2204. Fuel specification varies according to the working temperature. Please contact authorized Volvo dealer.

### Sulphur content

According to current USA legal requirement, the sulphur content in the diesel fuel must not exceed 0.0015 percent (15 ppm) by weight.

According to current EU/other countries legal requirements, the sulphur content in the diesel fuel must not exceed 0.001 percent (10 ppm) by weight.

### Bio-diesel fuel

Vegetable oils and / or esters, also called "bio-diesel", (e.g. rape-seed methyl ester RME fuel), which are offered on certain markets both as pure products and as mixed into the diesel fuel.

Volvo Construction Equipment accepts a maximum intermix of 7% bio-diesel fuel in the diesel fuel, ready mixed from the oil companies. A higher intermix than 7% of bio-diesel fuel may cause:

- Increased emission by nitrogen oxide, (thereby not meeting legal requirements)
- Shorter service life of engine and injection system
- Increased fuel consumption
- Altered engine output
- Shortening the engine oil change interval to a half
- Shortened service life of rubber materials in the fuel system
- Less good cold handling properties of the fuel
- Limit storage time for the fuel, which may cause clogging up of the fuel system if the machine is laid up for longer periods

### Warranty condition

The warranty does not cover damage caused by an intermix of more than 7% of bio-diesel fuel.