

Product: FB2800C Volvo Feller Bunchers Service Manual

Full Download: <https://www.arepairmanual.com/downloads/fb2800c-volvo-feller-bunchers-service-manual/>

V O L V O

Service Information

Document Title: Machine view	Function Group: 000	Information Type: Service Information	Date: 4/22/2026
Profile: FB2800C Volvo			

Component locations

Showing Selected Profile

Valid for serial numbers			
Model	Production site	Serial number start	Serial number stop
FB2800C Volvo			

Sample manual. Download All 1284 pages at:

<https://www.arepairmanual.com/downloads/fb2800c-volvo-feller-bunchers-service-manual/>

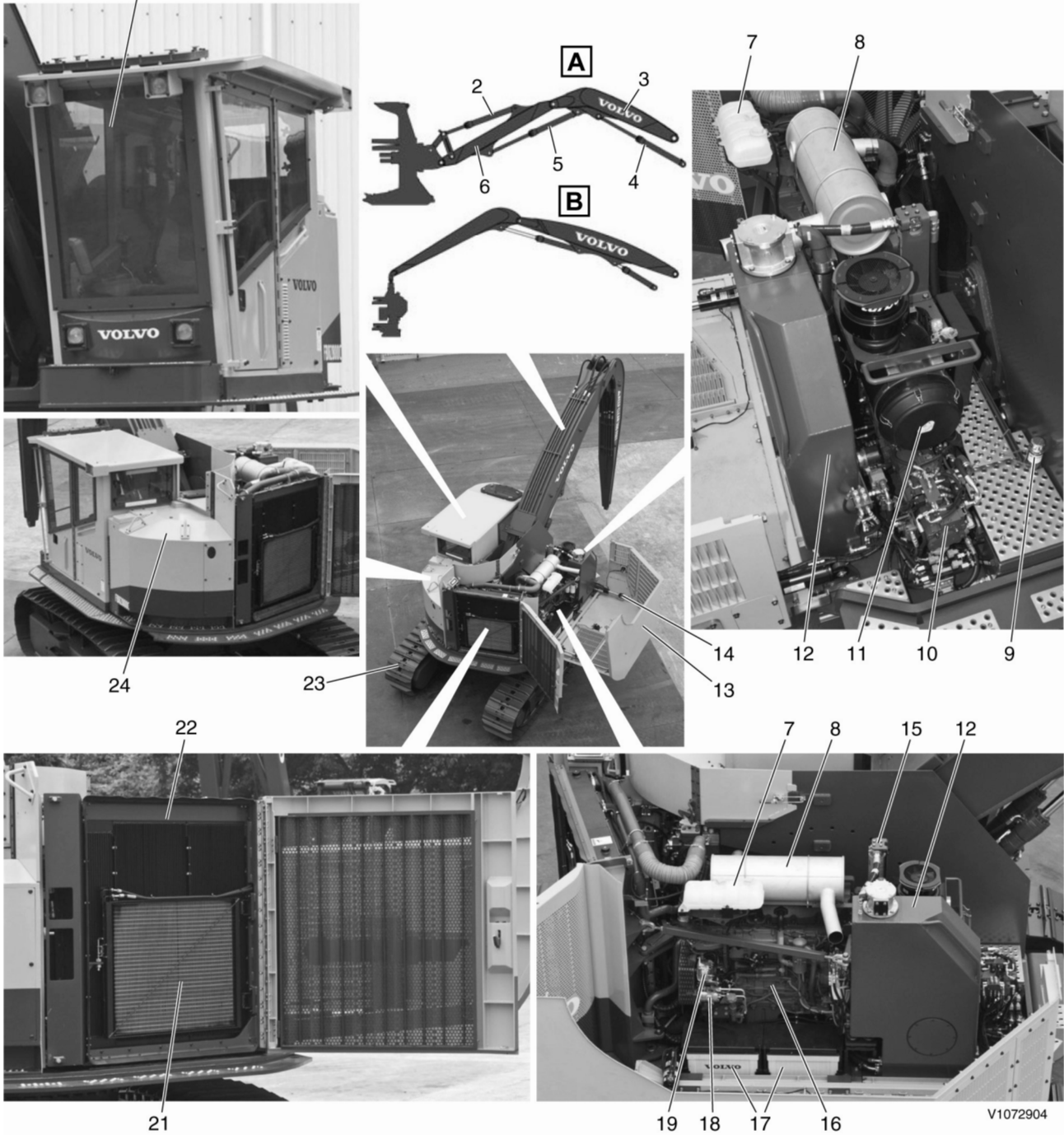

Figure 1
 Component position

A	Feller buncher Boom & Arm	B	Harvester Boom & Arm		
1	Operator Cab	9	Auxiliary tank	17	Battery
2	Dump cylinder	10	Main pumps (3 pumps)	18	Compressor
3	Boom	11	Air cleaner	19	Alternator
4	Boom cylinder	12	Hydraulic tank	20	-
5	Arm cylinder	13	Gull wing hood	21	Condenser
6	Arm	14	Gull wing cylinder	22	Radiator
7	Expansion coolant tank	15	Return filter	23	Track
8	Muffler	16	Engine	24	Fuel tank

Document Title: Product plates	Function Group: 000	Information Type: Service Information	Date: 4/22/2026
Profile: FB2800C Volvo			

Product plates

Showing Selected Profile

Valid for serial numbers			
Model	Production site	Serial number start	Serial number stop
FB2800C Volvo			

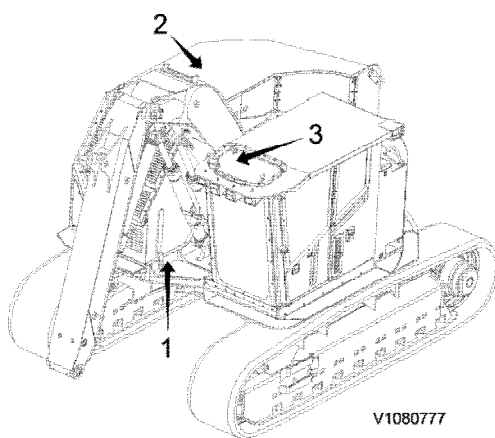

Figure 1

When ordering spare parts, and in all telephone enquiries or correspondence the model designation and the Product Identification Number (PIN) must always be quoted.

1. Product plate

The product plate on the machine shows the manufacturer's name and address, model designation, PIN, machine weight, engine output, production year and year of delivery. There is also room for the CE mark. The plate is positioned under the boom on the superstructure frame.

2. Engine

The engine product plate contains type designation and part and serial numbers and is positioned on the engine inside the rear engine cover on the right side of the machine.

3. Cab

The nameplate is attached on the inside of the cab and indicates the product number, serial number, model type, and weight.

Document Title: Volvo standard tightening torques	Function Group: 030	Information Type: Service Information	Date: 4/22/2026
Profile: FB2800C Volvo			

Volvo standard tightening torques

Showing Selected Profile

Valid for serial numbers			
Model	Production site	Serial number start	Serial number stop
FB2800C Volvo			

The tightening torques in the following tables apply to bolts and nuts with tensile strength. The tables should be used as a general instruction for tightening bolts and nuts without specified values. The charts contains values for course thread bolts and nuts.

Torque values should be increased with $\approx 10\%$, for flange bolts.

All standard torques for bolts are without surface treatment.

The standard torque for bolts lubricated with oil should be reduced with 20% of the given value.

Standard tightening torque charts

Bolt size Metric Coarse Threads	Tensile strength 8.8		Tensile strength 10.9	
	(Nm)	(lbf ft)	(Nm)	(lbf ft)
M5	6	4	8	6
M6	10	7	14	11
M8	25	18	35	26
M10	50	37	70	52
M12	87	64	122	90
M14	139	103	195	144
M16	213	157	299	220
M18	293	216	413	305
M20	416	307	585	432
M24	719	530	1010	745
M27	1060	782	1490	1100
M30	1140	840	2025	1493
M36	2500	1844	3600	2653

Bolt size Inch SAE Coarse Threads	Tensile strength 5		Tensile strength 8	
	(lbf ft)	(Nm)	(lbf ft)	(Nm)
1/4	10	13,6	14	19
5/16	21	28,5	29	39,3
3/8	37	50,2	52	70
7/16	59	80	84	114
1/2	90	122	128	174
9/16	130	176	184	250
5/8	180	244	254	345

3/4	320	434	451	612
7/8	515	700	728	988
1	775	1052	1091	1480
1 1/8	953	1290	1545	2100
1 1/4	1344	1823	2180	2960
1 3/8	1600	2170	2650	3600
1 1/2	2000	2714	3200	4340

Hydraulic connections, general

Before fitting pipe couplings, plugs and hoses:

- Make sure that the sealing surfaces are clean and free from pores or scratches.
- Check elastic seal rings for defects.
- Oil in threads, sealing surfaces and contact surfaces except for ORFS-connections (ORFS = O-Ring Face Seal).

Applying Torque correction factor by tool angle

Tool angle	Correction factor	
	ORFS	Stud-end
Allowable tolerance	±10%	- 0%, +10%
±0° ~ ±30°	5% over torque	
±30° ~ ±45°	20% over torque	
±45°	NOT allowable	

Tool access angle

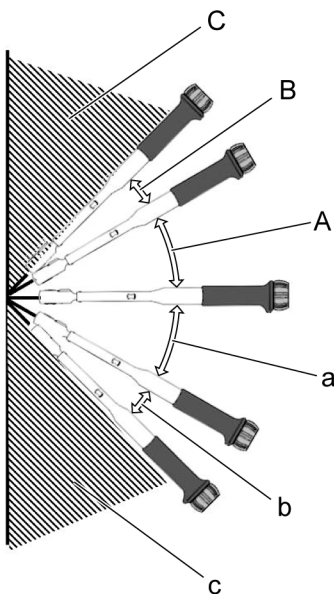

V1223202

Figure 1

Tool access angle

A: +0° ~ +30°

B: +30° ~ +45°

C: +45°

a: -0° ~ -30°

b: -30° ~ -45°

c: -45°

ORFS female swivel fitting

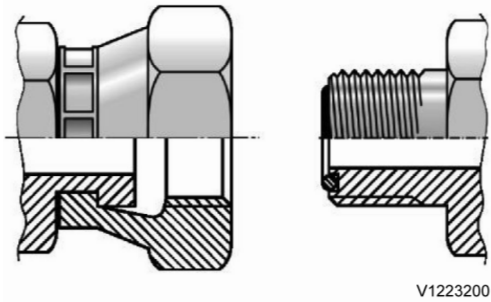

Figure 2

Thread s type	Assembl y position	Threads	Standard torque		±0° ~ ±30°		±30° ~ ±45°	
			(Nm)	(lbf ft)	(Nm)	(lbf ft)	(Nm)	(lbf ft)
UN- UNF	ORFS	UNF 9/16-18	29 ±3	21.4 ±2.2	30.5 ±3.1	22.1 ±2.2	36.5 ±3.7	26.9 ±2.7
		UN 11/16-16	44 ±4	32.5 ±3.0	46.2 ±4.6	34.1 ±3.4	55.4 ±5.5	40.9 ±4.1
		UN 13/16-16	63 ±6	46.5 ±4.4	66.2 ±6.6	48.8 ±4.9	79.4 ±7.9	58.6 ±5.9
		UNS 1-14	106 ±8	78.2 ±5.9	111.3 ±11.1	82.1 ±8.2	133.6 ±13.4	98.5 ±9.9
		UN 1 3/16-12	140 ±12	103.3 ±8.9	147.0 ±14.7	108.4 ±10.8	176.4 ±17.6	130.1 ±13.0
		UN 1 7/16-12	175 ±15	129.1 ±11.1	183.8 ±18.4	135.6 ±13.6	220.5 ±22.1	162.6 ±16.3
		UN 1 11/16-12	270 ±20	199.1 ±14.8	283.5 ±28.4	209.1 ±20.9	340.2 ±34.0	250.9 ±25.1
	Stud-end	UNF 7/16-20	21 +2.1	15.4 +1.5	22.1 +2.2	16.3 +1.6	26.5 +2.7	19.5 +2.0
		UNF 1/2-20	37 +3.7	27.3 +2.7	38.9 +3.9	28.7 +2.9	46.6 +4.7	34.4 +3.4
		UNF 9/16-18	47 +4.7	34.7 +3.5	49.4 +4.9	36.4 +3.6	59.2 +5.9	43.7 +4.4
		UNF 3/4-16	81 +8.1	59.7 +6.0	85.1 +8.5	62.8 +6.3	102.1 +10.2	75.3 +7.5
		UNF 7/8-14	141 +14.1	104.0 +10.4	148.1 +14.8	109.2 +10.9	177.7 +17.8	131.1 +13.1
		UN 1 1/16-12	189 +18.9	139.4 +13.9	198.5 +19.9	146.4 +14.6	238.1 +23.8	175.6 +17.6
		UN 1 5/16-12	284 +28.4	209.5 +21.0	298.2 +29.8	219.9 +22.0	357.8 +35.8	263.9 +26.4
UN 1 5/8-12	347 +34.7	255.9 +25.6	364.4 +36.4	268.8 +26.9	437.2 43.7	322.5 +32.3		

UN 1 7/8-12	425 +42.5	313.5 +31.4	446.3 +44.6	329.2 +32.9	535.5 +53.6	395.0 +39.5
----------------	-----------	-------------	-------------	-------------	-------------	-------------

G thread 30° cone female swivel fitting

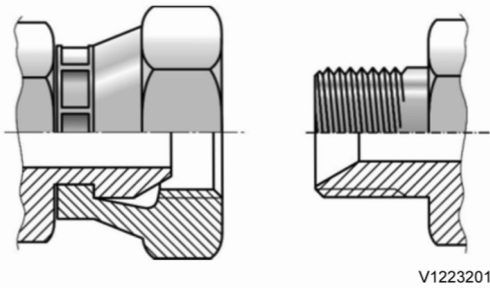

Figure 3

Thread s type	Assembl y position	Threads	Standard torque		±0° ~ ±30°		±30° ~ ±45°	
			(Nm)	(lbf ft)	(Nm)	(lbf ft)	(Nm)	(lbf ft)
PF	ORFS	G 1/4-19	25 ±2.5	18.4 ±1.8	26.3 ± 2.6	19.4 ±1.9	31.5 ±3.2	23.2 ±2.3
		G 3/8-19	49 ±4.9	36.1 ±3.6	51.5 ± 5.2	38.0 ±3.8	61.7 ±6.2	45.5 ±4.6
		G 1/2-14	59 ±5.9	43.5 ±4.4	62.0 ± 6.2	45.7 ±4.6	74.3 ±7.4	54.8 ±5.5
		G 3/4-11	119 ±11.9	87.8 ±8.8	125.0 ±12.5	92.2 ±9.2	149.9 ±15.0	110.6 ±11.1
		G 1-11	140 ±14	103.3 ±10.3	147.0 ±14.7	108.4 ±10.8	176.4 ±17.6	130.1 ±13.0
		G 1 1/4-11	173 ±17.3	127.6 ±12.8	181.7 ±18.2	134.0 ±13.4	218.0 ±21.8	160.8 ±16.1
		G 1 1/2-11	205 ±20.5	151.2 ±15.1	215.3 ±21.5	158.8 ±15.9	258.3 ±25.8	190.5 ±19.1
	Stud-end	G 1/8-19	22 +2.2	16.2 +1.6	23.1 +2.3	17.0 +1.7	27.7 +2.8	20.4 +2.0
		G 1/4-19	52 +5.2	38.4 +3.8	54.6 +5.5	40.3 +4.0	65.5 +6.6	48.3 +4.8
		G 3/8-19	85 +8.5	62.7 +6.3	89.3 +8.9	65.9 +6.6	107.1 +10.7	79.0 +7.9
		G 1/2-14	105 +10.5	77.4 +7.7	110.3 +11.0	81.4 +8.1	132.3 +13.2	97.6 +9.8
		G 3/4-11	210 +21	154.9 +15.5	220.5 +22.1	162.6 +16.3	264.6 +26.5	195.2 +19.5
		G 1-11	400 +40	295.0 +29.5	420.0 +42.0	309.8 +31.0	504.0 +50.4	371.7 +37.1
		G 1 1/4-11	525 +52.5	387.2 +38.7	551.3 +55.1	406.6 +40.7	661.5 +66.2	487.9 +48.8
G 1 1/2-11	630 +63.1	464.7 +46.5	661.5 +66.2	487.9 +48.8	793.8 +79.4	585.5 +58.6		

Document Title: Measurement conversion tables	Function Group: 030	Information Type: Service Information	Date: 4/22/2026
Profile: FB2800C Volvo			

Measurement conversion tables

Showing Selected Profile

Valid for serial numbers			
Model	Production site	Serial number start	Serial number stop
FB2800C Volvo			

Length

Unit	cm	m	km	in	ft	yd	mile
cm	1	0.01	0.00001	0.3937	0.03281	0.01094	0.000006
m	100	1	0.001	39.37	3.2808	1.0936	0.00062
km	100000	1000	1	39370.7	3280.8	1093.6	0.62137
in	2.54	0.0254	0.000025	1	0.08333	0.02777	0.000015
ft	30.48	0.3048	0.000304	12	1	0.3333	0.000189
yd	91.44	0.9144	0.000914	36	3	1	0.000568
mile	160930	1609.3	1.6093	63360	5280	1760	1

1 mm = 0.1 cm, 1 mm = 0.001 m

Area

Unit	cm ²	m ²	km ²	a	ft ²	yd ²	in ²
cm ²	1	0.0001	-	0.000001	0.001076	0.000012	0.155000
m ²	10000	1	0.000001	0.01	10.764	1.1958	1550.000
km ²	-	1000000	1	10000	1076400	1195800	-
a	0.01	100	0.0001	1	1076.4	119.58	-
ft ²	-	0.092903	-	0.000929	1	0.1111	144.000
yd ²	-	0.83613	-	0.008361	9	1	1296.00
in ²	6.4516	0.000645	-	-	0.006943	0.000771	1

1 ha = 100 a, 1 mile² = 259 ha = 2.59 km²

Volume

Unit	cm ³ = cc	m ³	Liter	in ³	ft ³	yd ³
cm ³ = m liter	1	0.000001	0.001	0.061024	0.000035	0.000001
m ³	1000000	1	1000	61024	35.315	1.30796
Liter	1000	0.001	1	61.024	0.035315	0.001308
in ³	16.387	0.000016	0.01638	1	0.000578	0.000021
ft ³	28316.8	0.028317	28.317	1728	1	0.03704
yd ³	764529.8	0.76453	764.53	46656	27	1

1 gal(US) = 3785.41 cm³ = 231 in³ = 0.83267 gal(UK)

Weight

Unit	g	kg	t	oz	lb
g	1	0.001	0.000001	0.03527	0.0022
kg	1000	1	0.001	35.273	2.20459
t	1000000	1000	1	35273	2204.59
oz	28.3495	0.02835	0.000028	1	0.0625
lb	453.592	0.45359	0.000454	16	1

1 tonne(metric) = 1.1023 ton(US) = 0.9842 ton(UK)

Pressure

Unit	kgf/cm ²	bar	Pa=N/m ²	kPa	lbf/in ²	lbf/ft ²
kgf/cm ²	1	0.98067	98066.5	98.0665	14.2233	2048.16
bar	1.01972	1	100000	100	14.5037	2088.6
Pa=N/m ²	0.00001	0.001	1	0.001	0.00015	0.02086
kPa	0.01020	0.01	1000	1	0.14504	20.886
lbf/in ²	0.07032	0.0689	6894.76	6.89476	1	144
lbf/ft ²	0.00047	0.00047	47.88028	0.04788	0.00694	1

1 kgf/cm² = 735.56 Torr(mmHg) = 0.96784 atm

Approximate conversions

SI	Conversion	Non-SI	Conversion	SI
Unit	Factor	Unit	Factor	Unit
Torque				
newton meter (N·m)	x 10.2	= kgf·cm	x 0.8664	= (lbf·in)
newton meter (N·m)	x 0.74	= lb·ft	x 1.36	= N·m
newton meter (N·m)	x 0.102	= kgf·m	x 7.22	= (lbf·ft)
Pressure (Pa = N/m²)				
kilopascal (kPa)	x 4.0	= in. H ₂ O	x 0.249	= kPa
kilopascal (kPa)	x 0.30	= in. Hg	x 3.38	= kPa
kilopascal (kPa)	x 0.145	= psi	x 6.89	= kPa
(bar)	x 14.5	= psi	x 0.069	= (bar)
(kgf/cm ²)	x 14.22	= psi	x 0.070	= (kgf/cm ²)
(newton/mm ²)	x 145.04	= psi	x 0.069	= (bar)
megapascal (MPa)	x 145	= psi	x 0.00689	= MPa
Power (W = J/s)				
kilowatt (kW)	x 1.36	= PS (cv)	x 0.736	= kW
kilowatt (kW)	x 1.34	= HP	x 0.746	= kW
kilowatt (kW)	x 0.948	= Btu/s	x 1.055	= kW
watt (W)	x 0.74	= ft·lb/s	x 1.36	= W

Note: () non-si unit

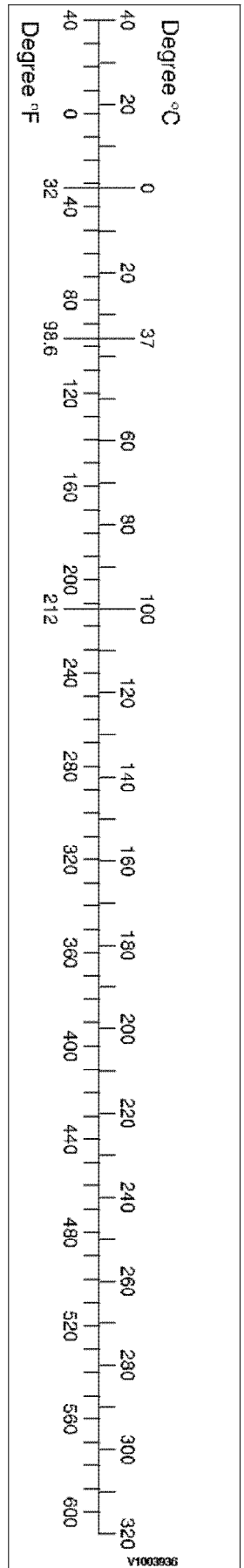

Approximate conversions

SI Unit	Conversion Factor	Non-SI Unit	Conversion Factor	SI Unit

Document Title: Specification, filling capacities	Function Group: 030	Information Type: Service Information	Date: 4/22/2026
Profile: FB2800C Volvo			

Specification, filling capacities

Showing Selected Profile

Valid for serial numbers			
Model	Production site	Serial number start	Serial number stop
FB2800C Volvo			

Refill capacities

		Approximate refill capacities
Reservoir	Kind of fluid	Litres (US gal)
Engine oil pan	Engine oil	35 (9.2)
Hydraulic oil tank	Hydraulic oil	269 (71)
Hydraulic system, total	Hydraulic oil	525 (139)
Slew gearbox	Gear oil	6.0 (1.6)
Track gearbox (each)	Gear oil	3.5 (0.9)
Fuel tank	Diesel fuel	1635 (482)
Slew ring gear	Grease	53 (14)
Cooling system	Coolant	60 (15.8)

- Specified capacity: Total amount of oil including oil for components and oil in piping.
- Refill capacity: Amount of oil needed to refill reservoir during periodic inspection and maintenance.

Document Title: Engine, specifications	Function Group: 030	Information Type: Service Information	Date: 4/22/2026
Profile: FB2800C Volvo			

Engine, specifications

Showing Selected Profile

Valid for serial numbers			
Model	Production site	Serial number start	Serial number stop
FB2800C Volvo			

Specifications

Item	Unit	Specifications
Make	-	VOLVO
Model	-	D9BEAE3
Type	-	4-stroke, 6-cylinder, water cooling, direct injection, diesel engine
Rated output (Net)	kW (HP) (PS) / rpm	241 (323) (328) / 2100
Maximum torque (Net)	Nm (kgf m) (lbf ft) / rpm	1690 (172.4) (1250) / 1300
Number of cylinder	-	6
Bore x Stroke	mm (inch)	120 × 138 (1.72 × 5.43)
Total displacement	Liter (US gal)	9.4 (2.48)
Compression ratio	-	19.2 : 1
Low idle (No-load)	rpm	800 ± 50
High idle (No-load)		2200 ± 35
Firing order	-	1 – 5 – 3 – 6 – 2 – 4

Document Title: Engine, weight	Function Group: 030	Information Type: Service Information	Date: 4/22/2026
Profile: FB2800C Volvo			

Engine, weights

Showing Selected Profile

Valid for serial numbers			
Model	Production site	Serial number start	Serial number stop
FB2800C Volvo			

Engine, dry, approx.	1110 kg (2425 lbs)
----------------------	--------------------

Document Title: Tightening torque, cylinder head	Function Group: 030	Information Type: Service Information	Date: 4/22/2026
Profile: FB2800C Volvo			

Tightening torque, cylinder head

Showing Selected Profile

Valid for serial numbers			
Model	Production site	Serial number start	Serial number stop
FB2800C Volvo			

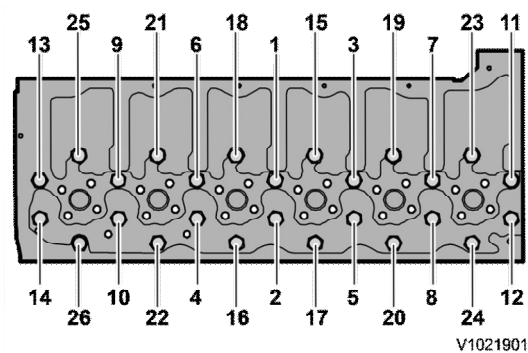

Figure 1

Tightening sequence, cylinder head, D9

NOTE!

Tighten the bolts in the sequence shown in the figure.

Sep 1	60 Nm (44 lbf ft)
Sep 2	60 Nm (44 lbf ft)
Sep 3	90±5° Angle-tightening
Sep 4	90±5° Angle-tightening

Document Title: Valve clearance, specifications	Function Group: 030	Information Type: Service Information	Date: 4/22/2026
Profile: FB2800C Volvo			

Valve system specifications

Showing Selected Profile

Valid for serial numbers			
Model	Production site	Serial number start	Serial number stop
FB2800C Volvo			

D9B

Valve system	
Valve device	Overhead camshaft
Valve clearance, cold engine	
Inlet valves (adjusting)	0.20 mm (0.008 in)
Inlet valves (checking)	0.15 — 0.25 mm (0.006 — 0.010 in)
Exhaust valves (adjusting)	0.80 mm (0.031 in)
Exhaust valves (checking)	0.75 — 0.85 mm (0.029 — 0.033 in)
Clearance double rocker arm — base circle on camshaft	Use gauge 88820016
Lock nut, injector adjusting screw	45 ±5°
Locking nut, valve adjusting screw	60 ±5°

Tightening torques required for valve and injector adjustment

Lock nut, valve adjusting screw (inlet/exhaust)	60° ±5° after contact
Lock nut, injector adjusting screw	45° ±5° after contact
Valve cover D9B	30 N·m (22 lbf·ft)

Unit injector tightening torques

<p>Bolt, attaching yoke, unit injector, new copper sleeve. First tightening:</p> <ol style="list-style-type: none"> 20 N·m (15 lbf·ft) Angle tightening: 180° Loosen the bolt for the unit injector's attaching yoke before the second tightening. <p>Second tightening:</p> <ol style="list-style-type: none"> 20 N·m (15 lbf·ft) Angle tightening: 60° <p>Old copper sleeve — 20 N·m (15 lbf·ft), then tighten through 60°</p>	
<p>Bolt, attaching yoke, unit injector (reused copper sleeve). First tightening:</p>	

<ol style="list-style-type: none">1. 20 N·m (15 lbf·ft)2. Angle tightening: 60°	
Lock nut for adjusting screw, unit injector	Adjust the unit injector's rocker arm to zero clearance. Tighten down the adjusting screw another 3 — 4 bolt edges (180° — 240°). Angle tighten the adjusting screw's lock nut 45° ±5°.

Document Title: Flywheel, weight	Function Group: 030	Information Type: Service Information	Date: 4/22/2026
Profile: FB2800C Volvo			

Flywheel, weight

Showing Selected Profile

Valid for serial numbers			
Model	Production site	Serial number start	Serial number stop
FB2800C Volvo			

Flywheel, approx.	45 kg (99 lbs)
-------------------	----------------

Document Title: Lubrication specifications	Function Group: system, 030	Information Type: Service Information	Date: 4/22/2026
Profile: FB2800C Volvo			

Lubrication system, specifications

Showing Selected Profile

Valid for serial numbers			
Model	Production site	Serial number start	Serial number stop
FB2800C Volvo			

Oil pressure, min. at low idle speed (warm engine)	min. 270 kPa (2.7 bar) (39 psi)
Oil pressure, operating speed (warm engine)	300–550 kPa (3–5.5 bar) (44–80 psi)

Document Title: Fuel feed pump, specifications	Function Group: 030	Information Type: Service Information	Date: 4/22/2026
Profile: FB2800C Volvo			

Fuel feed pump, specifications

Showing Selected Profile

Valid for serial numbers			
Model	Production site	Serial number start	Serial number stop
FB2800C Volvo			

Fuel feed pump	
Type	Gear pump
Feed pressure	100-300 kPa (14.5 – 43.5 psi)

Document Title: Cooling specifications	Function Group: system, 030	Information Type: Service Information	Date: 4/22/2026
Profile: FB2800C Volvo			

Cooling system, specifications

Showing Selected Profile

Valid for serial numbers			
Model	Production site	Serial number start	Serial number stop
FB2800C Volvo			

Cooling system	
Type	Closed system
	Hydraulically driven cooling fan
Thermostat begins open at	86 °C (187 °F)
Thermostat fully open at	95 °C (203 °F)
Radiator cap valve opens at	75 kPa (0.75 bar) (11 psi)

Document Title: Instrument control unit I-ECU, specifications	Function Group: 030	Information Type: Service Information	Date: 4/22/2026
Profile: FB2800C Volvo			

Instrument control unit I-ECU, specifications

Showing Selected Profile

Valid for serial numbers			
Model	Production site	Serial number start	Serial number stop
FB2800C Volvo			

Instrument control unit, I-ECU connector, specifications

Items	Connectors
IA	18 pin Terminal: AMP 174935-1 Housing: AMP 368509-1
IB	14 pin Terminal: AMP 174934-1 Housing: AMP 368508-1

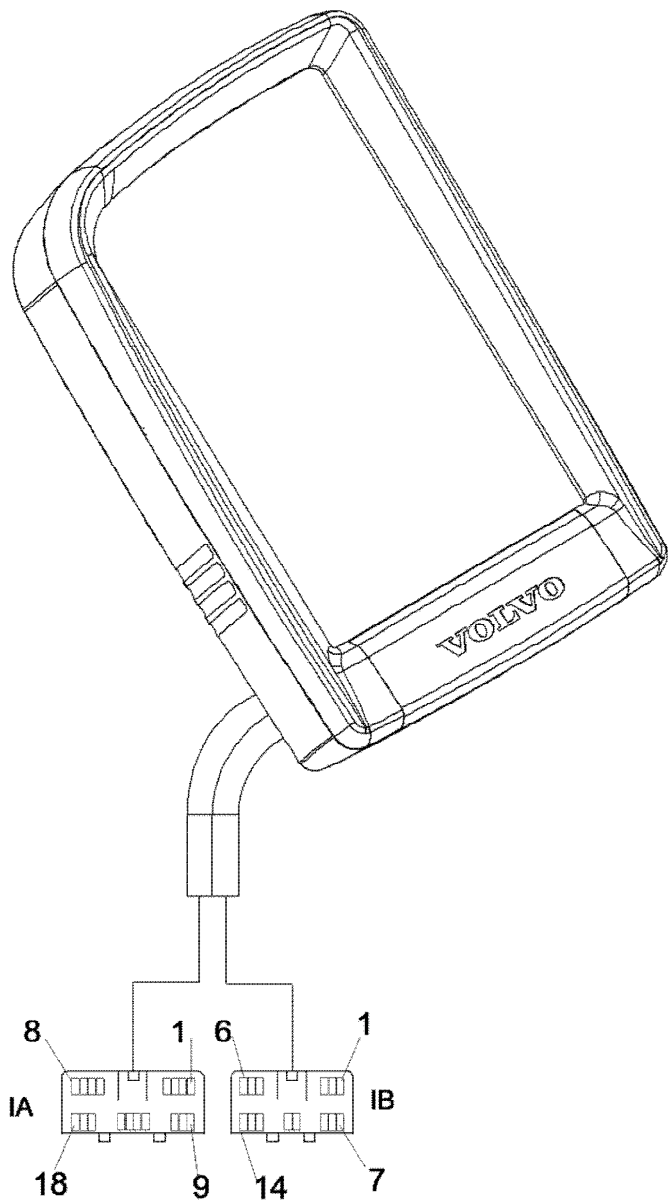

V1043754

Figure 1
I-ECU, connector

IA	Connector, IA
IB	Connector, IB

Document Title: Electronic climate control unit ECC, specification	Function Group: 030	Information Type: Service Information	Date: 4/22/2026
Profile: FB2800C Volvo			

Electronic climate control unit ECC, specification

Showing Selected Profile

Valid for serial numbers			
Model	Production site	Serial number start	Serial number stop
FB2800C Volvo			

Electronic climate control unit ECC, specification

Item	Specifications
Operating voltage	8–36 VDC
Operating temperature	-40–70 °C (-40–158 °F)
Connector	TYCO 1-963484-1 with seal 963361-1

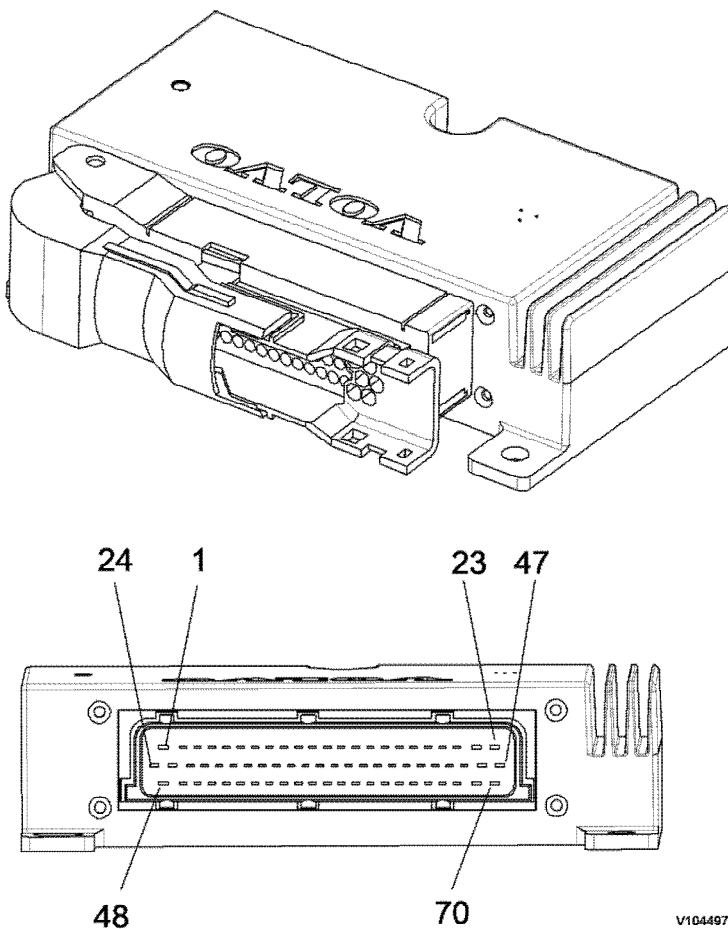

Figure 1
Electronic climate controller, ECC

Document Title: Battery, specifications	Function Group: 030	Information Type: Service Information	Date: 4/22/2026
Profile: FB2800C Volvo			

Battery, specifications

Showing Selected Profile

Valid for serial numbers			
Model	Production site	Serial number start	Serial number stop
FB2800C Volvo			

Battery, specifications

Items	Specifications
Quantity	2 in series
Battery voltage (nominal)	Min. 12.65 V / battery Max. 12.95 V / battery
Capacity	210 Ah
Weight	56.4 kg (124.3 lb)
Battery disconnecter	Connected to negative (-)
Acid density at 27 °C (81 °F)	Min. 1.265 g/ccm Max. 1.300 g/ccm

Document Title: Alternator, specifications	Function Group: 030	Information Type: Service Information	Date: 4/22/2026
Profile: FB2800C Volvo			

Alternator, specifications

Showing Selected Profile

Valid for serial numbers			
Model	Production site	Serial number start	Serial number stop
FB2800C Volvo			

Alternator, specifications

Items	Description
Type	Alternating current (AC)
Voltage	28.0 V
Max. revolution	12000 rpm
Current rating	40A at 1800 rpm, 110 A at 6000 rpm
Weight	7.8 kg (17.1 lb)

Document Title: Work lights and extra lights, specifications	Function Group: 030	Information Type: Service Information	Date: 4/22/2026
Profile: FB2800C Volvo			

Work lights and extra lights, specifications

Showing Selected Profile

Valid for serial numbers			
Model	Production site	Serial number start	Serial number stop
FB2800C Volvo			

Item	Specifications	
Rated voltage	24 V	
Electric power consumed	Halogen (H3)	70 W / bulb
	Xenon	35 W / bulb

Document Title: Travel alarm, specifications	Function Group: 030	Information Type: Service Information	Date: 4/22/2026
Profile: FB2800C Volvo			

Travel alarm, specifications

Showing Selected Profile

Valid for serial numbers			
Model	Production site	Serial number start	Serial number stop
FB2800C Volvo			

Specifications

Item	Specifications
Operating voltage	DC 18 – 32 V
Current	0.4 A
Sound pressure	115 ± 5 dB
Operating temperature	-20 – 50 °C (-4 – 122 °F)

Document Title: Start switch, specifications	Function Group: 030	Information Type: Service Information	Date: 4/22/2026
Profile: FB2800C Volvo			

Start switch, specifications

Showing Selected Profile

Valid for serial numbers			
Model	Production site	Serial number start	Serial number stop
FB2800C Volvo			

Specifications

Item	Specifications
Maximum current	B-BR, B-ACC : 30 A B-R1, B-R2 : 60 A B-C : Momentary 75 A, Continuous 22 A
Insulation resistance	1 MΩ or more (500 V megohmmeter)

Wire specifications

No.	Wire specifications
2	B ⁺ , AVS 5.0 Y
3	BR, AVS 3.0 R/W
5	ACC, AVS 3.0 R
23	R2, AVS 5.0 W
7	C, AVS 3.0 R/SB
26	R1, AVS 3.0 R/GN



Document Title: Control lockout lever switch, specifications	Function Group: 030	Information Type: Service Information	Date: 4/22/2026
Profile: FB2800C Volvo			

Control lockout lever switch, specifications

Showing Selected Profile

Valid for serial numbers			
Model	Production site	Serial number start	Serial number stop
FB2800C Volvo			

Items	Specifications
Operating force	230 gf (0,5 lbf)
Reacting force	20 gf (0,05 lbf)
Nominal voltage	DC 30V, 5A
Ambient temperature	-40 - 90 °C (-40 - 194 °F)
Insulation resistance	Over 100 MΩ
Contact resistance	Below 100 mΩ
Connector	AMP EJ ser. mark2 + RECEP housing & male terminal (3p)