

Document Title: Description EW200	Function Group: 000	Information Type: Service Information	Date: 3/26/2026
Profile:			

Description EW200

The machine is wheel excavator with a weight between 15.7 and 18.0 tonnes.

A standard machine consists of the following three main parts:

- superstructure
- undercarriage
- digging unit

Superstructure frame with boom attachment, counterweight, machine housing and cab

The engine is a water cooled, six-cylinder, four-stroke, direct-injection, turbocharged diesel engine with an output of 107 kW (146 hp) and the type designation Volvo TD61GE. The engine powers the hydraulic system of the excavator via a pump gearbox. Three pumps for the working hydraulics are connected to this gearbox on the standard version of the machine. A separate pump (tandem pump) for the servo-hydraulic steering circuit is fitted on the diesel engine timing gear casing cover.

The machine has triple-circuit hydraulics with Volvo Excavators priority system and COS (= Capacity Optimised System). Thereby all three pumps can be used for separate excavating movements. The utilisation of the pumps is controlled by a so called Mode Selector through the following three programmes:

- HLD = Heavy Lift Device
- ECO = Economy
- CAP = Capacity

The pumps are controlled through PSC (Pressure Sensing Control) in order to avoid stalling the diesel-engine.

The superstructure is slewed with the aid of an axial piston motor. Between engine and slewing ring there is a slew brake, gearbox and slewing pinion. The pinion runs against the internal teeth of the slewing ring. The slewing ring connects the superstructure with the undercarriage. A centre passage connects the superstructure and the undercarriage hydraulically.

The cab has ventilation filters and is prepared for air conditioning. The cab contains a computerised monitoring system for the diesel engine and the hydraulic system. Under the operator's seat there is also an electrical distribution box where most of the fuses and relays are positioned.

Under cariager with two stabilisers at the rear and a dozer blade at the front

The propulsion of the machine is achieved with the help of a hydraulic piston motor of bent axis type. This drives the front and rear axle over a two speed gear box. So the machine has 4-wheel drive.

The axles are provided with hub reduction gears and drum brakes.

The machine has two stabilisers that can be individually operated and have hydraulic locks

The parking brake is a drum brake placed on the travel gear box. The brake is applied by spring force and release by hydraulic pressure.

The machine can have different dual and single wheels. This book covers the common alternatives.

Undercarriage with crawler unit and travel motors

Propulsion of the machine is achieved through two two-stage hydraulic motors driving the tracks. The motors are provided with hydraulic brakes. The brakes are negative, that is locked/applied by spring loading and only released when they are actuated by servo-pressure.

Rollers and idlers are greased for life.

Digging equipment with boom, dipper arm and bucket

The digging equipment is connected to the superstructure frame through the boom attachment.

The boom cylinder movement is provided with float position for higher excavating speed and smoother operation.

A hose rupture valve is fitted on the boom cylinder.

Depending on choice of attachment, various combinations of boom, dipper arm and attachments are available. This manual
[Sample manual. Download All 187 pages at: https://www.arepairmanual.com/downloads/ew200-volvo-excavator-service-manual/](https://www.arepairmanual.com/downloads/ew200-volvo-excavator-service-manual/)

Product: EW200 Volvo Excavator Service Manual

Full Download: <https://www.arepairmanual.com/downloads/ew200-volvo-excavator-service-manual/>
describes the most common alternatives.

Sample manual. Download All 187 pages at:

<https://www.arepairmanual.com/downloads/ew200-volvo-excavator-service-manual/>

Document Title: Product Identification Signs	Function Group: 000	Information Type: Service Information	Date: 3/26/2026
Profile:			

Product Identification Signs

Product Identification Signs and stamped-in markings for EW200

The machine on the synoptic picture is equipped with a two-piece boom which is an option.

The adjacent illustrations, which do not apply to a specific machine model, show which signs and markings there are on the machine and where they can be found.

When ordering spare parts and in all enquiries by telephone or correspondence the model designation and the Reg. No. should always be stated.

When applicable the stamped-in data on separate components should also be stated.

Item. No.

1. **Product identification sign** with model designation and number is positioned on the outside of the cab under the rear left side window.
2. **The sign for the bucket** with part number, modification number, weight and capacity is positioned on top of the bucket to the left of the dipper arm attachment.
3. **The diesel engine type designation**, product and serial number are stamped onto the left side of the engine at the upper edge of the cylinder block.
4. **The undercarriage part number** and modification number are stamped obliquely in front of and to the right of the slewing ring.
5. **The superstructure part number**, modification number and the machine Reg. No. are stamped into the right or the left boom attachment.
6. **The part number and modification number of the hydraulic cylinders** are stamped into the envelope surface of the cylinder cover at the oil connection at the piston rod end of the cylinders.
7. **The part number and modification number of the piston rods** are stamped into the end surface of the piston rods.
8. **The identification numbers of front axle (A) and rear axle (B)** are either stamped into the differential housing or can be found on a sign there.

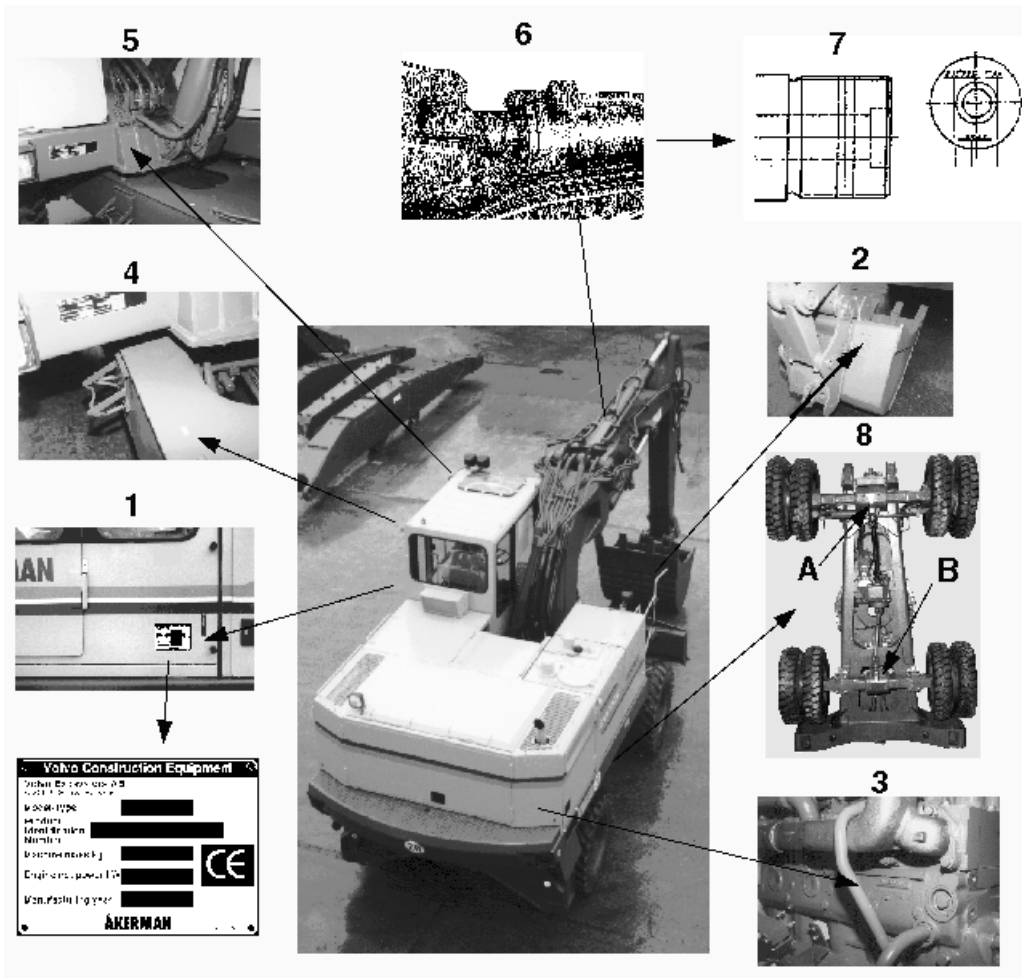

Figure 1

Document Title: Cylinder data	Function Group: 030	Information Type: Service Information	Date: 3/26/2026
Profile:			

Cylinder data

Boom cylinder 4.65 m (15 ft 3 in) and 5.2 m (17 ft 0.7 in)

Cylinder inner diameter	160 mm (6.30 in)
Piston rod diameter	105 mm (4.13 in)
Stroke	1125 mm (3 ft 8.29 in)
Piston force, out	523 kN (53.3 Mp) (117413 lbf)
Piston force, out in HLD	603 kN (61.5 Mp) (135374 lbf)

Boom cylinder for 2-piece boom

Cylinder inner diameter	160 mm (6.30 in)
Piston rod diameter	105 mm (4.13 in)
Stroke	1005 mm (3 ft 3.56 in)
Piston force, out	523 kN (53.3 Mp) (117413 lbf)
Piston force, out in HLD	603 kN (61.5 Mp) (135374 lbf)

Adjusting cylinder for 2-piece boom

Cylinder inner diameter	125 mm (4.92 in)
Piston rod diameter	70 mm (2.76 in)
Stroke	700 mm (2 ft 3.56 in)
Piston force, out	319 kN (32.5 Mp) (71616 lbf)

Dipper arm cylinder

Cylinder inner diameter	140 mm (5.51 in)
Piston rod diameter	90 mm (3.54 in)
Stroke	1100 mm (3 ft 7.31 in)
Piston force, out	400 kN (39.2 Mp) (89800 lbf)
Piston force, out in HLD	462 kN (47.1 Mp) (103719 lbf)

Bucket cylinder

Cylinder inner diameter	125 mm (4.92 in)
Piston rod diameter	80 mm (3.15 in)
Stroke	850 mm (3 ft 9.46 in)
Piston force, out	319 kN (32.5 Mp) (71616 lbf)
Piston force, out in HLD	368 kN (37.6 Mp) (82616 lbf)

Document Title: Main dimensions	Function Group: 030	Information Type: Service Information	Date: 3/26/2026
Profile:			

Main dimensions

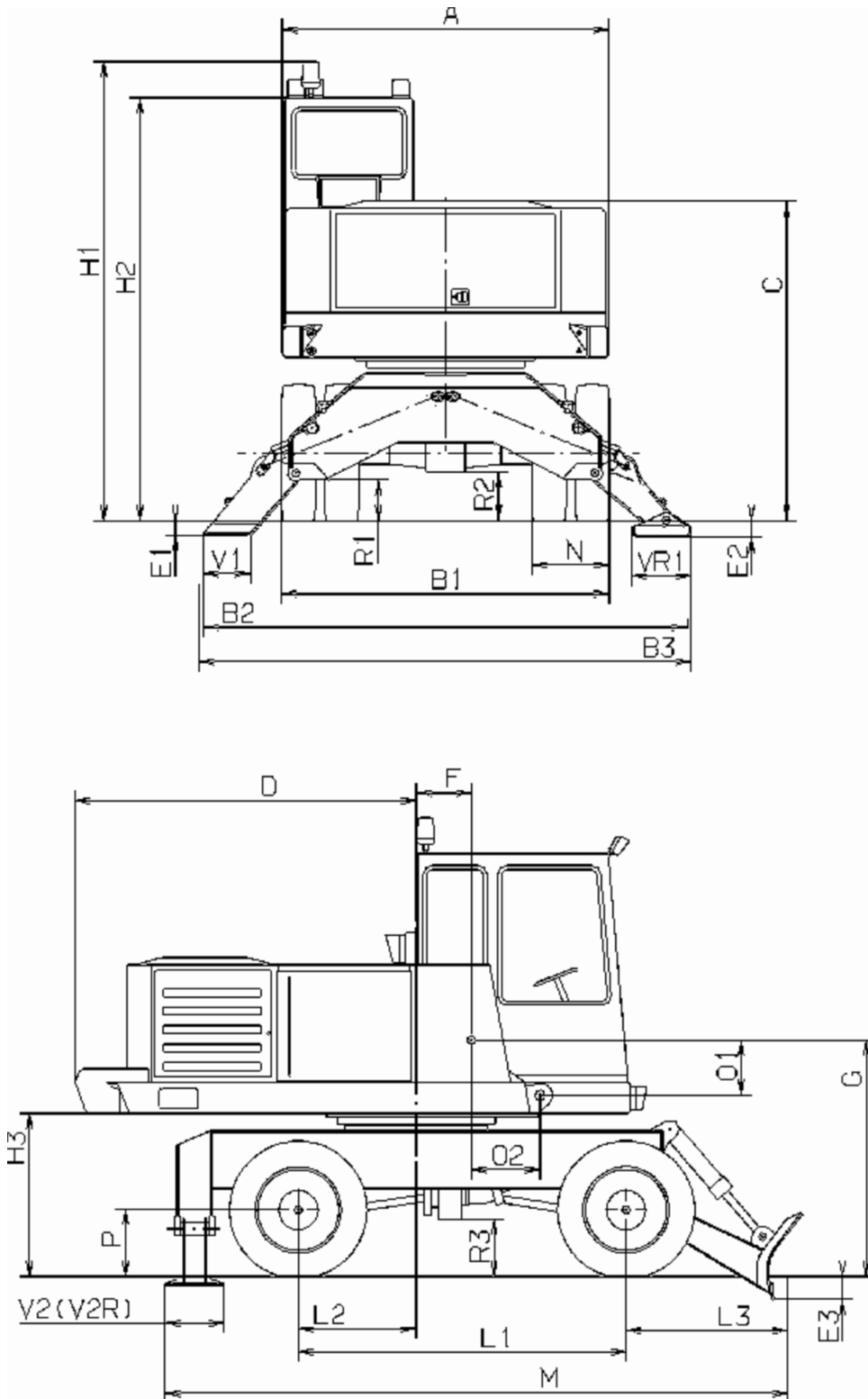

A	2.49 m
B1	2.50 m
B2	3.69 m
B3	3.75 m
C	2.41 m
D	2.60 m
E1	0.12 m
E2	0.13 m
E3	0.17 m
F	0.42 m
G	1.80 m
H1	3.49 m
H2	3.22 m
H3	1.18 m
L1	2.50 m
L2	0.90 m
L3	1.24 m
M	4.75 m
N	0.59 m
O1	0.42 m
O2	0.52 m
P	0.50 m
	0.53 m
R1	0.33 m
R2	0.36 m
R3	0.43 m
V1	0.36 m
VR1	0.45 m
V2	0.44 m
VR2	0.50 m

Figure 1

**The data only applies to machines equipped according to factory standard.
For machines equipped in another way - see the respective specifications.**

Capacities

Fuel tank	290 litre (76,6 US gal)
Hydraulically powered fuel filling pump, capacity, approx.	90 litre (23,8 US gal) per minute
Cooling system (incl. glycol)	32 litre (7.0 US gal)
Hydraulic system, total	320 litre (84.5 US gal)
Hydraulic oil tank	220 litre (58.1 US gal)
Diesel engine (lubricating oil)	22 litre (5.8 US gal)
Pump gearbox	3.1 litre (0.8 US gal)
Slewing gearbox	16.5 litre (4.4 US gal)
Travel gearbox	4.5 litre (1.2 US gal)
Front axle	9,0 litre (2.4 US gal)
Rear axle	10,5 litre (2.8 US gal)
Hub reduction gear	4 x 3 litre (4 x 0.8 US gal)

Weights

Working weight complete excavator equipped with	5,20 m boom (17 ft 0.7 in) 2,4 m dipper (7 ft 10.5 in) 950 l bucket 2600 kg counter weight	4,65 m boom (15 ft 3.0 in) 2,4 m dipper (7 ft 10.5 in) 825 l bucket 2200 kg counter weight
Total weight incl. dozer blade	17480 kg (38540 lb)	16950 kg (37370 lb)
Axle load (incl dozer blade) Front axle	7680 kg (16930 lb)	7750 kg (17090 lb)
Axle load (incl dozer blade) Rear axle	9800 kg (21600 lb)	9200 kg (20280 lb)

Digging equipment incl. dipper arm and quickfit bracket (excl. bucket)	Boom 4.65 m (15 ft 3.0 in)	Boom 5.2 m (17 ft 0.7 in)
Dipper arm 2.0 m (6 ft 6.7 in)	2295 kg (5060 lb)	2430 kg (5360 lb)
Dipper arm 2.4 m (7 ft 10.5 in)	2375 kg (5240 lb)	2410 kg (5310 lb)
Dipper arm 2.8 m (9 ft 2.2 in)	2450 kg (5400 lb)	2585 kg (5700 lb)

Additional weights

Superstructure, incl. counterweight (2600 kg) and diesel engine	9090 kg (19998 lb)
Diesel engine, incl. pump gearbox and pumps	850 kg (1870 lb)

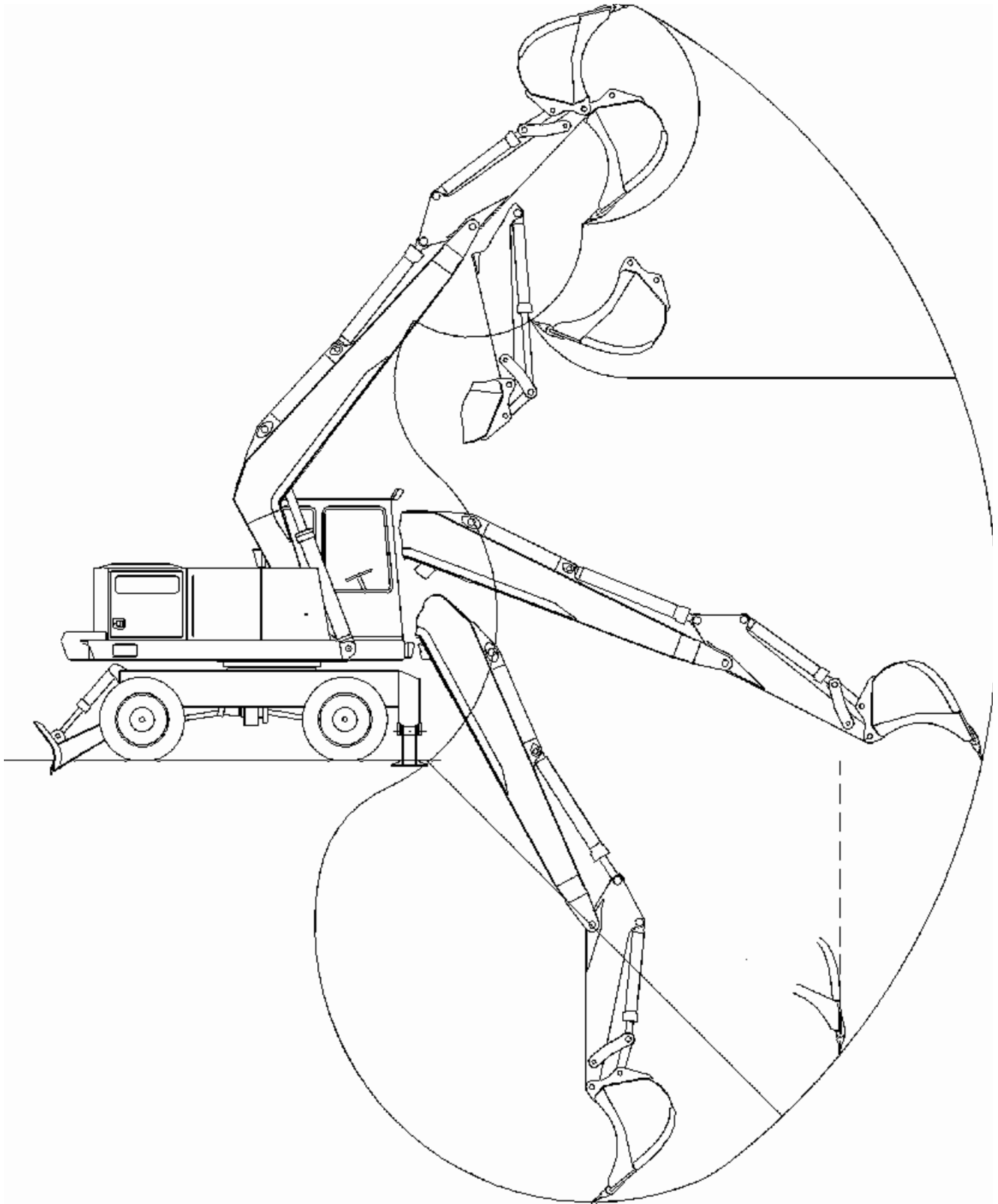

Figure 2

**The data only applies to machines equipped according to factory standard.
For machines equipped in another way - see the respective specifications.**

Excavating data in metre and feet and inches

Digging or excavating data

Boom length	4.65 m (15 ft 3 in)			5.20 m (17 ft 1 in)		
Dipper arm	2.0 m	2.4 m	2.8 m	2.0 m	2.4 m	2.8 m

digging
equipment at
full reach (A)

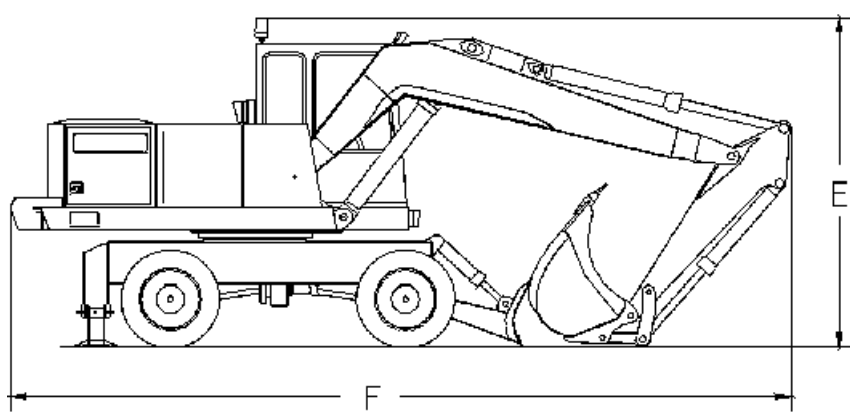
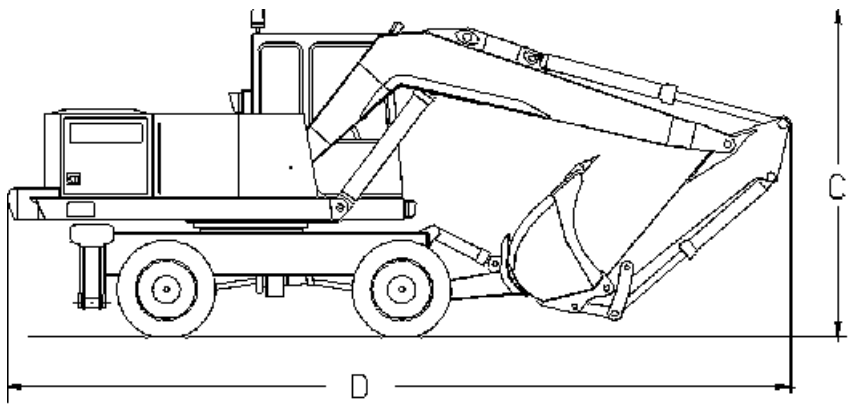

2.0 m	2.4 m	2.8 m
A= 3.5m	A= 3.5m	A= 3.5m
B= 10.8m	B= 11.2m	B= 11.5m
C= 3.5m	C= 3.6m	C= 3.8m
D= 8.3m	D= 8.2m	D= 8.0m
E= 3.5m	E= 3.5m	E= 3.7m
F= 8.3m	F= 8.2m	F= 8.1m

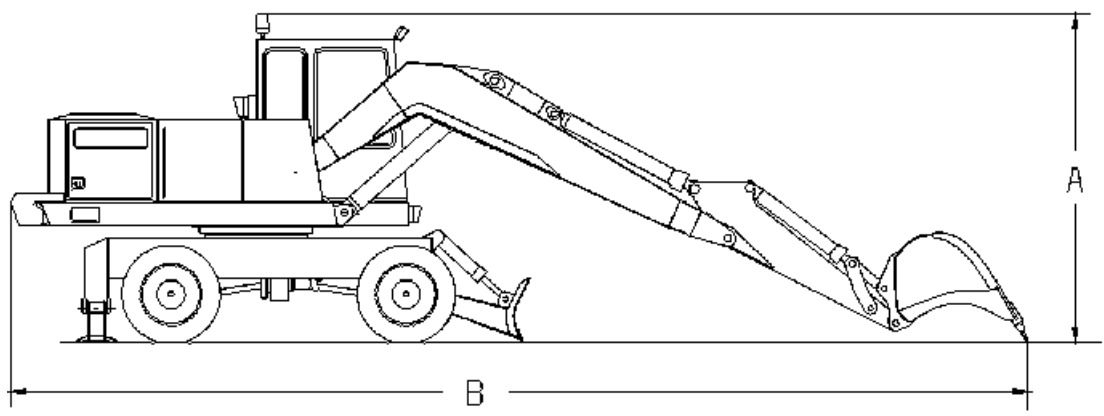
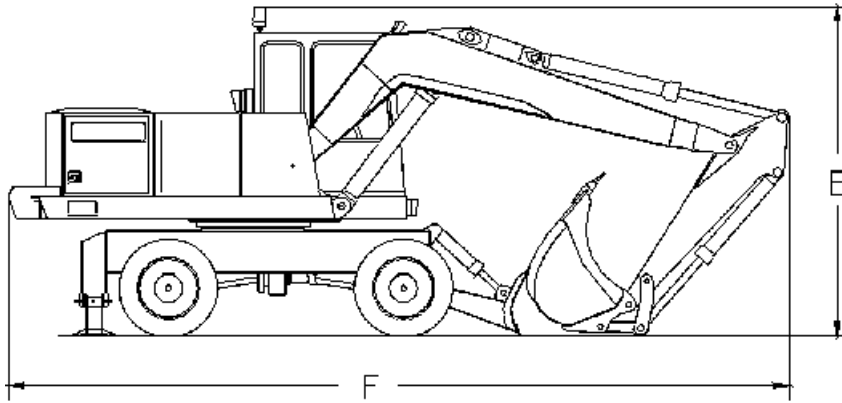
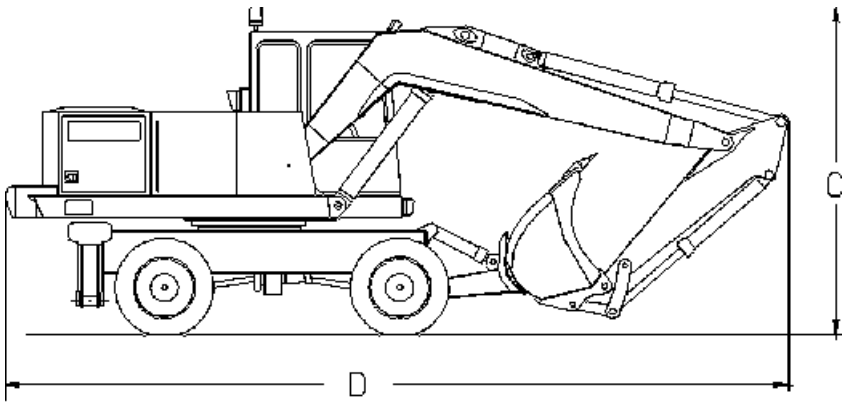

Figure 3



2.0 m	2.4 m	2.8 m
A= 3.5m	A= 3.5m	A= 3.5m
B= 10.8m	B= 11.2m	B= 11.5m
C= 3.5m	C= 3.6m	C= 3.8m
D= 8.3m	D= 8.2m	D= 8.0m
E= 3.5m	E= 3.5m	E= 3.7m
F= 8.3m	F= 8.2m	F= 8.1m

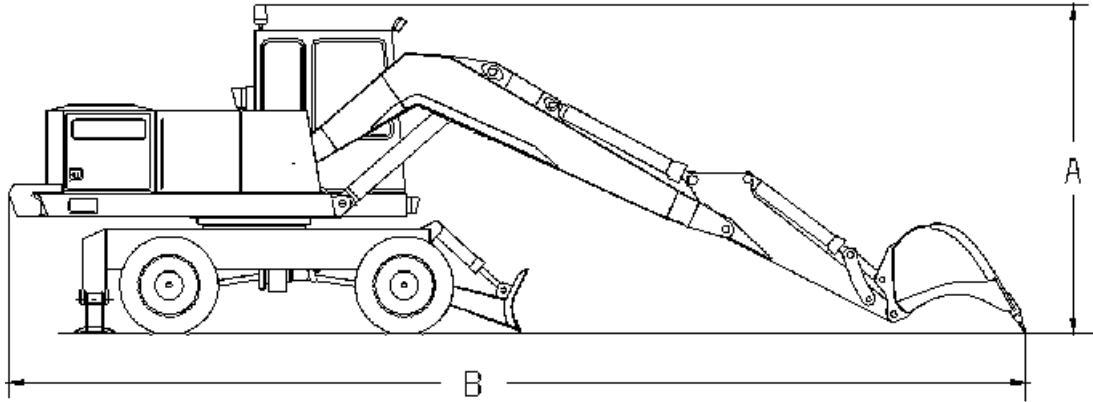

Figure 4

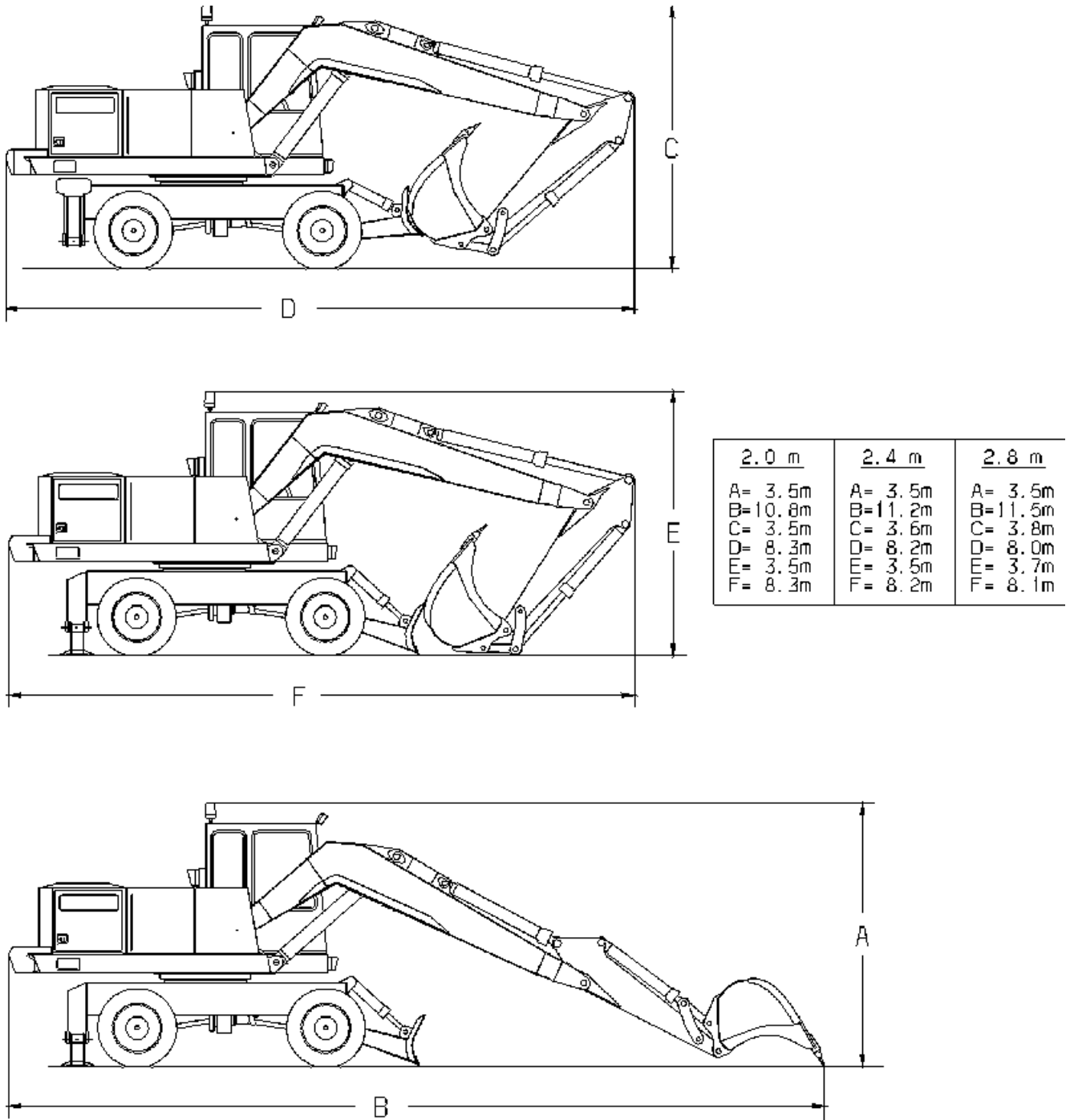

Figure 5

Tightening torques

Tightening torques for nuts and bolts of steel

This standard applies when tightening with a torque wrench under the following conditions:

Condition No.	Surface finish (see below table)		Lubrication condition	Nut
		Bolt		
1	Unt.	Unt.	Oiled	
2	Phos.	Unt. or Phos.	Oiled	
3	Gzb	Unt. or Gzb	Dry	
4	a	Unt. or Gzb	Oiled	

Unt. = Untreated
Phos. = Phosphatized

Gzb = Bright galvanized

Gzv = Hot galvanized

When machine-tightening (using a nut runner) the tightening torque shown in the tables must be reduced by approx. 5% because of the greater variation of the obtained torque and thus to avoid reaching the yield point of the bolt.

When the supporting surface has a hardness lower than 200 HB a washer should be positioned under both bolt head and nut, in order to reduce the risk of settlement in the material with consequent reduction of the prestressing force.

When fitting, the tightening should be made to the prescribed torque without stopping in order to avoid that the higher static friction releases the torque wrench at a too low torque.

Recommended tolerances for tightening torque

TIGHTENING TORQUES in Nm (lbf ft)

	-50 (37)	51-100 (37.5 - 73.5)	101-200 (74 - 147)	201-400 (148 - 295)	401-1000 (296 - 738)	1001- (739 -)
Tolerance	± 2	± 5	± 10	± 20	± 40	± 50

Thread M	Tensile strength class						Thread M	12.9	Mv in Nm (lbf ft) Condition No.
	8.8			10.9					
	Mv in Nm (lbf ft) Condition No.			Mv in Nm (lbf ft) Condition No.					
	1	2	3	1	2		1		
M6	10 (7.4)	10 (7.4)	10 (7.4)	15 (11.1)	12 (8.9)	20 (14.8)	M6		
M8	25 (18.4)	25 (18.4)	25 (18.4)	35 (25.8)	30 (22.1)	40 (29.5)	M8		
M10	50 (37)	45 (33.2)	50 (37)	65 (48)	55 (41)	80 (59)	M10		
M12	80 (59)	80 (59)	90 (66)	120 (89)	100 (74)	140 (103)	M12		
M14	130 (96)	125 (92)	140 (103)	180 (135)	160 (118)	220 (160)	M14		
M16	200 (150)	190 (140)	210 (155)	280 (210)	240 (180)	340 (250)	M16		
M20	390 (290)	370 (270)	420 (310)	540 (400)	470 (350)	650 (480)	M20		
M22	520 (380)	500 (370)	560 (410)	730 (540)	630 (470)	880 (650)	M22		
M24	670 (490)	640 (470)	720 (530)	940 (690)	800 (590)	1120 830)	M24		
M30	1310 (970)	1260 (930)	1400 (1030)	1840 (1360)	1580 (1170)	2210 (1630)	M30		
M36	2280 (1680)	2190 (1620)	2440 (1800)	3210 (2370)	2760 (2040)	3850 (2840)	M36		

Thread UNC	Tensile strength class						Thread UNC	12.9	Mv in Nm (lbf ft) Condition No.
	8.8			10.9					
	Mv in Nm (lbf ft) Condition No.			Mv in Nm (lbf ft) Condition No.					
	1	2	3	1	2		1		
1/4	10 (7.4)	10 (7.4)	10 (7.4)	15 (11.1)	13 (9.6)	20 (14.8)	1/4		
5/16	20 (14.8)	20 (14.8)	20 (14.8)	30 (22.1)	25 (18.4)	40 (29.5)	5/16		
3/8	40 (29.5)	35 (25.8)	40 (29.5)	55 (41)	45 (33.2)	70 (52)	3/8		
7/16	60 (44)	60 (44)	65 (48)	90 (66)	75 (55)	110 (81)	7/16		
1/2	100 (74)	90 (66)	100 (74)	130 (96)	110 (81)	170 (125)	1/2		
9/16	140 (103)	130 (96)	140 (103)	190 (140)	160 (118)	240 (180)	9/16		
5/8	190 (140)	180 (135)	200 (150)	260 (190)	220 (160)	330 (240)	5/8		
3/4	320 (240)	310 (230)	350 (260)	460 (340)	390 (290)	570 (420)	3/4		

1	770 (570)	740 (550)	830 (610)	1090 (800)	940 (690)	1360 (1000)	1
1 1/8	1090 (800)	1050 (770)	1170 (860)	1550 (1140)	1330 (980)	1930 (1420)	1 1/8
1 1/4	1530 (1130)	1470 (1080)	1640 (1210)	2160 (1590)	1860 (1370)	2690 (1980)	1 1/4
1 3/8	2020 (1490)	1940 (1430)	2160 (1590)	2850 (2100)	2450 (1810)	3550 (1620)	1 3/8
1/2	2650 (1950)	2550 (1880)	2840 (2090)	3750 (2770)	3230 (2380)	4680 (3450)	1 1/2

Mv =Tightening torque

When converting from N to kgf: 1 N = 0.1020 kgf

When converting from N m to lbf ft, multiply the Nm value by 0.73756

Tightening torque for wheel nuts

Thread M	Torque in Nm (lbf ft)
M22 x 1,5	420 ± 23 (310 ± 17)

Recommendations for hydraulic oil

Type of oil	Viscosity	Ambient temperature	Compatibility	Remark
SHS 32	ISO VG 32 HR	- 30 to + 35°C	Mixable with SHS 46	
SHS 46	ISO VG 46 HR	- 15 to + 50°C	Mixable with SHS 32	
PANOLIN HLP SE SYNTH 46 (Biodegradable)	Same as for mineral oil	- 15 to +50°C	Mixable with mineral oil but not other synthetic oils	Before changing from mineral oil to synthetic oil - contact Volvo Construction Equipment AB - Service
BP BIOHYD SE 46 (Biodegradable)	Same as for mineral oil	- 15 to + 50°C	Mixable with mineral oil but not other synthetic oils	Before changing from mineral oil to synthetic oil - contact Volvo Construction Equipment AB - Service

The machine is normally delivered with oil of typ the SHS 46.

Digging equipment bearings

Bearing location	Pin diameter 50 - 80 mm								
		Degree of wear mm							
		Pin - Lug				Total			
		25%	50%	75%	100%	25%	50%	75%	100%
Boom - boom attachment	0.4	0.7	1.0	1.3	0.8	1.2	1.7	2.2	
Dipper arm - bucket	0.7	1.2	1.8	2.5	1.6	2.4	3.3	4.3	
Boom - dipper arm									
Hydraulic	0.5	0.9	1.4	1.9	1.2	1.8	2.5	3.3	

cylinders								
Bucket linkage								

Bearing location	Pin diameter >80-120								
	Degree of wear mm								
	Pin - Lug					Total			
	25%	50%	75%	100%	25%	50%	75%	100%	
Boom - boom attachment	0.4	0.7	1.1	1.5	0.9	1.3	1.9	2.5	
Dipper arm - bucket	0.8	1.4	2.1	2.9	1.8	2.7	3.8	4.9	
Boom - dipper arm									
Hydraulic cylinders	0.6	1.1	1.6	2.2	1.4	2.1	2.9	3.8	
Bucket linkage									

Measurements of new parts

Total theoretical maximum play:
 Pin diameter 50 - 80 mm (1.96 - 3.15 in) = 0.262 mm (0.010 in)
 Pin diameter >80 - 120 mm (3.15 - 4.72 in) = 0.316 mm (0.012 in)

Document Title: Specifications	Function Group: 030	Information Type: Service Information	Date: 3/26/2026
Profile:			

Specifications

The data only applies to machines equipped according to factory standard.
For machines equipped in any other way - see the respective specifications.

Hydraulic system

Pump 1 (P1)

Pump 1 is a pressure controlled, bent axis, piston pump that primarily powers the slewing.	
Max. flow	64 litre (16.9 US gal) per minute

Pump 2 and 3 (P2, P3)

P2 and P3 are power and pressure controlled, bent axis, piston pumps that powers digging equipment and tracks.	
Max. flow	2 x 114 litre (30 US gal) per minute

Servo pump (PS)

(PS) is a gear pump that powers the servo circuit.	
Flow approx.	25 litre (6.6 US gal) per minute

Steering pump (PST)

Flow approx	30 (7.9 US gal) per minute
-------------	----------------------------

Hydraulic pressure

The pressures are given in MPa.

Conversion of MPa to bar: 1 MPa = 10 bar. MPa to psi = multiply MPa value by 145.038

PRESSURE-SETTING VALUES

FUNCTION	DESIGNATION	PRESSURE MPa	PRESSURE psi
Pressure limiting, servo	PSA	6.5	940
Pressure limiting, P1	AA	34.0	4930
Slewing acceleration	AD	32.0	4640
Slewing retardation	AE	22.0	3190
Pressure control, P1	AG	28.0	4060
Pressure limiting, P2 & P3	AB & AC	30.0	4350
Pressure limiting, P2, optional equipment	AO	30.0	4350
Pressure control, P2 & P3	AH & AM	26.0	3770
Power control, P2 & P3	AK & AN	19.0	2750
Control pressure, travel motor	AT	22.0	3190
Pressure limiting for hammer	AR		
Pressure according to hammer supplier			

Diesel engine

Volvo TD61GE

TD61GE is a water cooled, direct injected, six cylinder, four stroke, turbocharged diesel engine.

Output gross at 1800 rpm (According to ISO 2534 Intermittent, gross)	107 kW (146 hp)
Cylinder bore	98.43 mm (3.875 in)
Stroke	120 mm (4.724 in)
Displacement	5.48 litres

The engine is equipped with an electric preheating coil in order to facilitate starting in cold weather. Optional equipment is a butane fired engine preheater. Standard equipment also includes a Fuel-Miser for automatic lowering of the engine speed when the operating controls are not activated.

Diesel Engine Speeds

High idling speed: Maximum speed when engine is not loaded.

Rated speed: Nominal speed at max. stated output.

Setting tolerances

Low idling speed: +40/-20

High idling speed: +25

Conversion of kW to hp: 1 kW = 1.36 hp

Engine data

Reg. no.	Engine type	Low idling speed rpm	High idling speed rpm	Rated speed rpm	Output kW
2401	TD61GE	600	1960	1800	107 ISO 2534

Electrical system, 24 V

System voltage	24 V
Alternator	28 V / 55 A
Battery, 4 pcs.	12 V
Battery capacity	2 x 60 Ah

Under carriage

Propulsion

The propulsion of the machine is achieved with the aid of an hydraulic piston motor of bent axis type. This drives the front and rear axle over a two speed gear box (4-wheel drive). The axles are provided with hub reduction gears and drum brakes. The front axle is pivoted and can pivot $\pm 7^\circ$ to compensate for unevenness of the ground. The stabilisers and the dozer blade can be operated separately or together to get the machine quickly into digging.

The brake system meets with the demands of standard ISO 3450.

The wheel brakes are servo hydraulic drum brakes in to separate brake circuits, one for each axle.

The parking brake is a drum brake placed on the travel gear box. The brake is applied by spring force and release by hydraulic pressure.

As so called digging brakes the wheel brakes and the parking brake are used together.

Security system: Two brake circuits with one accumulator each. One circuit or the parking brake is enough to meet with the demands of the safety regulations.

Dual wheels, standard	10.00 - 20 PR14
Max. tractive effort	114 kN (11,4 Mp)(25628 lbf)
Travel speed, on road	0-30 km/h (18,6 mile/h)
Travel speed, off road	0-7 km/h (4,3 mile/h)
Turning radius	8,0 m (26ft 3in)

Slewing system

The superstructure is slewed with the aid of an axial piston motor.

Between motor and slewing ring there is a slew brake, gearbox and slewing pinion in engagement with the internal teeth of the slewing ring.

Slewing speed	7.9 rpm
90° slewing, from start to stop	5.0 s
180° slewing, from start to stop	7.0 s
(Empty bucket - digging equipment at full reach)	

Tyre dimensions and tyre pressures

Designation	Make	Art. No.	Rim inches/ number of holes	Air pressure			
				MPa	±MPa	psi	±psi
10.00-20 14PR	Nokia	215428	7,0 - 20/10	0,75	0,03	109	4
11.00-20 16PR	Nokia	210839	7,5 - 20	0,75	0,03	109	4
12.00-20 18PR	Nokia	211407	8,00 x 20	0,75	0,03	109	4
11.00-20 E20 16PR XR	Michelin	24107	7,5 - 20	0,75	0,03	109	4 CU.
10.00x20x7,5 Massive tyre	Freightm.	214143	7,5-20	0,75	0,03	109	4
10.00-20 16PR	Kumho	210573	7,0 - 20/10	0,75	0,03	109	4
10.00-20 D20 16PR XR	Michelin	26356	7,0 - 20/10	0,75	0,03	109	4
500/60x22,5 PR16SF ELS	Nokia	211276	16,00 - 22,5	0,5	0,02	73	2
18R22.5X Typ F	Michelin	214315	14,00 - 22,5	0,7	0,03	102	4
18R19.5X Typ F	Michelin	25585	14,00 - 19,5	0,7	0,03	102	4
600/50x22,5 16PR SB 423	Trelleborg	213046	20,00 x 22,5	0,5	0,02	73	2
11,00-20 16PR K 431	Kumho	211960	7,5 - 20	0,75	0,03	109	4
10.00-20 14 PR K 423	Kumho	14216060	7,0 - 20/10	0,75	0,03	109	4

Document Title: Dieseling in hydraulic cylinders	Function Group: 170	Information Type: Service Information	Date: 3/26/2026
Profile:			

Dieseling in hydraulic cylinders

If hydraulic oil mixed with air is compressed, the temperature rises and at a certain temperature some of the oil evaporates and ignites, thus so called dieseling takes place.

Dieseling causes burned piston seals and rings.

This problem is avoided if, after repairs, the lines to the hydraulic cylinders are vented in the following way. The hydraulic cylinders should be operated between end of stroke positions until the air is removed from the system. The load on the hydraulic system must be kept very low, while the air is being removed.

The dipper arm and bucket cylinders should be positioned so that any air will rise and gather at the outlet end of the cylinder. This means that the outlet end should be the highest point.

The piston should be at the opposite end of the cylinder. Wait a minute or so from the moment the cylinder is placed in this position, before you run the piston towards the outlet side.

Repeat this procedure several times (for instance three to five times).

Boom cylinders, which cannot be positioned as described above, must be run in and out about five times without any load in the bucket.

NOTE!

If the cylinders become pressurised through lifting the machine or lifting a load in the bucket before the air in the system has been removed, the seals will probably be damaged.

If a cylinder is to be pressure-tested after it has been repaired, the piston rod should be run in and out a few times, before the pressure is increased up to the test pressure.

Document Title: Filtering hydraulic oil	Function Group: 170	Information Type: Service Information	Date: 3/26/2026
Profile:			

Filtering hydraulic oil

Op nbr

[Filtering unit 14031832](#)

[Disposable filter 14025665](#)

Filtering must be carried out in the following cases:

1. After major work on the hydraulic system for example work on the valve block, when changing tank and in cases of breakdown of a pump, hydraulic motor or a cylinder.
 - After a test has proven that the oil is contaminated.
 - On machines with re-occurring malfunctions of the hydraulic system.
2. Secure the filtering unit to the hydraulic tank. The unit is secured with the bolts for the hydraulic tank filter cover.
3. Warm up the hydraulic oil to 35 °C if needed. Stop the diesel engine.
4. Remove the protective caps A and B from the top of the hydraulic tank.
5. Connect the suction line of the filtering unit to connection B and the return line to connection A, marked in the figure.
6. Start the filtering unit and run the hydraulic oil in the tank through the unit for approx. one hour.
7. Change the filter in the tank if the hydraulic oil was heavily contaminated.
8. Start the diesel engine and continue the filtering for a further two hours while operating the hydraulic functions of the machine. Make sure that all hydraulic functions are activated so that the oil in the entire system is filtered. Carry out the movements carefully so that the filtering unit is not dislocated from the tank.
9. Remove the filtering unit and re-fit the blind flanges to the tank.
After the filtering unit has been used, its filter container should be cleaned and a new disposable filter fitted.

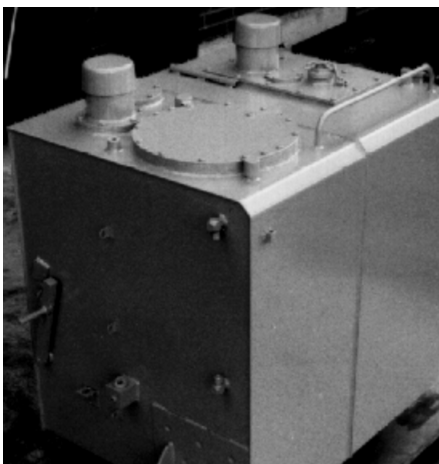

Figure 1

Document Title: Instructions for shrinking	Function Group: 170	Information Type: Service Information	Date: 3/26/2026
Profile:			

Instructions for shrinking

1. General
2. Equipment
3. Heating
4. Assembling
5. Dismantling

1. General

By "shrinkage fit" is meant that, at a certain temperature difference and a consequent change in measurements, a shaft and a hub can be assembled and become fixed when the temperature of the heated part drops and its size shrinks.

Usually the shaft is kept at room temperature, or preferably below, whereas the hub is heated in different ways. This method used, for instance, when fitting a gear wheel to a shaft, is described below.

2. Equipment

- a. Heating equipment
A gas burner with an adequate nozzle or an electric hot plate with an output of approx. 1500 - 2000 W, and a diameter of approx. 250 mm (10 in).
- b. Measuring equipment
A shrinkage gauge Part.no. 14194288 for checking the correct measurement change in the hub.

3. Heating

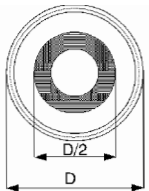

Figure 1

Prior to heating, make sure that the hub and shaft are free from burrs and defects that might otherwise impede the assembling of the parts.

- a. Hot plate
Heat the gear wheel on the plate until the shrinkage gauge can be easily pushed into the hub. Avoid exposing the measuring pin to heat or cold, as this will change its measurement. We recommend cooling the gauge to room temperature in between the times the gauge is used.
- b. Gas flame
Concentrate the heating to a circular area around the hub corresponding to about half of the gear wheel diameter, see [\[Invalid linktarget\]](#) . If the heat around the hub is to result in an increase in the diameter of the hole, some heat has to be added to the outer edge of the gear wheel. This has to be done with care so as not to damage the hardening of the gear teeth. Proceed with the heating of the gear wheel until the shrinkage gauge can be easily inserted in the hub.

4. Assembling

Once the assembling has been started, the parts should be assembled as quickly as possible, to avoid heat from being transferred to the shaft, thus making assembling difficult or causing the parts to jam before they are correctly assembled. It is also important that the shaft is securely fixed in a vertical position in case the gear wheel should jam in an oblique

position. With the shaft securely fixed it is easier to wriggle off the gear wheel quickly. If the gear wheel becomes fixed to the shaft before it is in its correct position, try to separate the wheel from the shaft as quickly as possible. If this is not possible, allow the parts to cool and proceed as described in the paragraph "Dismantling".

5. Dismantling

Try to press the shaft out of the hub without heating the hub. If this fails, apply pressure to the shaft in a hydraulic press. Gradually heat the hub, while the parts are fitted in the press, until the shaft loosens. If the heat is transmitted into the shaft, the shaft diameter increases with the risk that the fit will become too tight, thus making dismantling impossible. If the parts tend to bind because of the heat being transmitted into the shaft, stop the operation and cool off the parts. Then make a new dismantling attempt.

Document Title: Instructions for vacuum pump	Function Group: 170	Information Type: Service Information	Date: 3/26/2026
Profile:			

Instructions for vacuum pump

Special tool: Vacuum pump 14190806



WARNING

When working on the hydraulic system of the machine, avoid contact with leaking hydraulic oil under pressure. Also avoid contact with hot hydraulic oil.

Fitting

NOTE!

The diesel engine must never be running when the sealing boot is blocking the breather filter of the hydraulic tank as this might cause serious damage to the pump.

- Place the pump on the hydraulic oil tank.
- Connect the plug to the 24 Volt socket on the machine and route the cable so that it will not be pinched anywhere.
- Fit the sealing boot on the cap for the breather filter of the hydraulic tank and connect the hose from the pump to the sealing boot as shown in **[Invalid linktarget]** .
- Start the pump with the switch and adjust the valve so that the partial vacuum **never** exceeds 300 millibar (8.86 in Hg).

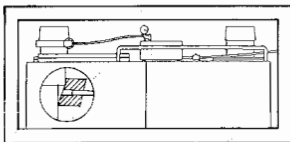

Figure 1

NOTE!

If the partial vacuum exceeds 300 mb (8.86 in Hg), there is a risk that the gearbox oil may be sucked into the hydraulic system and that the hydraulic oil tank may be damaged.

Removing

- Turn off the current for the pump with the switch.
- Remove the hose from the sealing boot and then remove the sealing boot from the hydraulic oil tank cap.
- Remove the plug from the 24 V socket on the machine.
- Remove the pump.

Document Title: Measuring backlash in slewing system	Function Group: 170	Information Type: Service Information	Date: 3/26/2026
Profile:			

Measuring backlash in slewing system

The total backlash in the slewing system is the sum of the play or clearance between all parts in the system, such as the radial play in the slewing ring and ball bearings, wear of gear teeth, play in splined joints if present.

This means that the measurement of the backlash does not give any definite information about, for instance, the tooth flank wear of the slewing ring. The measured backlash only indicates whether the play is abnormal and thus whether a more thorough inspection is necessary. See the Specifications for the given limits.

Measuring procedure:

1. Place the machine on level ground, with the boom and dipper arm over the idlers, in the longitudinal direction of the undercarriage.
2. Extend the boom and dipper arm and lock the slew brake with the bucket off the ground.
3. Place the magnetic base of a dial indicator gauge on the super structure with the flexible arm over the slewing ring pan and mount a pointed metal pin in the retainer.
4. Adjust and secure the pin about 1 mm (0.04 in) from the pan wall.
5. Push the boom and dipper arm by hand until the superstructure stops at one end of the backlash and mark the position of the metal point on the slewing ring pan.
6. Move the superstructure in the opposite direction to the end of the backlash and measure the distance between the measuring point and the mark previously made.

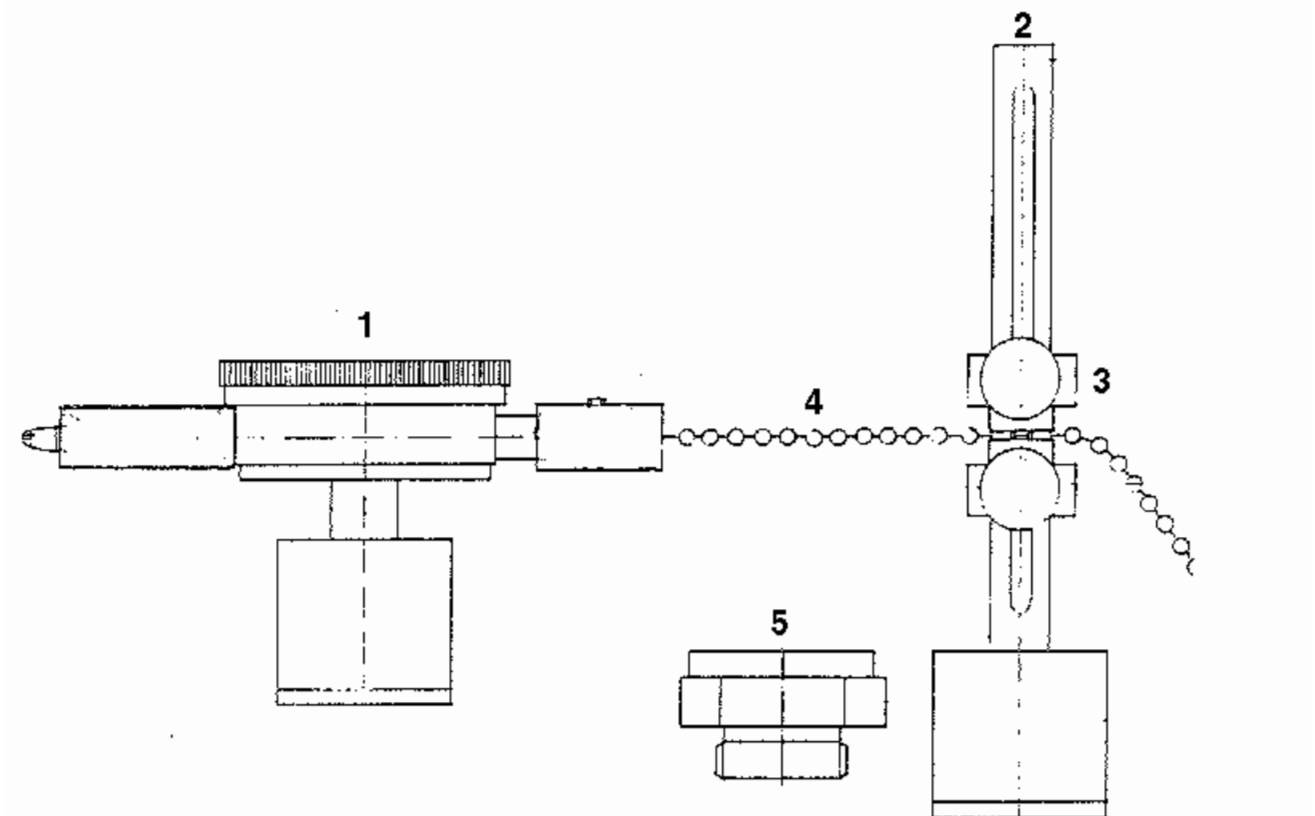

Figure 1

Document Title: Measuring radial clearance in the digging equipment bearings	Function Group: 170	Information Type: Service Information	Date: 3/26/2026
Profile:			

Measuring radial clearance in the digging equipment bearings

Op nbr

[Measuring tool 14290000.](#)

The item numbers refer to
[Invalid linktarget] .

1. Place the machine on firm, level ground. Determine the position of the digging equipment where the play of the bearing to be measured is the greatest.

Measuring the overall clearance

2. Determine the measuring direction and place the dial gauge (item 1) on the bearing lug of the pin. Place the dial gauge with the pointer in the intended measuring direction and turned so that the ball link points to where the column (item 2) is to be placed.
3. Place the column (item. 2) on the reference part, i.e. part with bushing or link bearing, and lock the bottom locking sleeve (item. 3) so that its sharp edge coincides with the centre height of the dial gauge pointer.
4. Pull the ball link (item. 4) through the column slit and lock it between the lower and upper locking sleeves. Tension the ball link so that the dial gauge pointer moves to the middle of the measuring range.
5. Move the machine parts, so that the play in the bearings can be read off on the gauge.

Measuring clearance between bearing lug and pin

6. Determine the measuring direction and place the dial gauge (item 1) on the end surface of the pin. Place the gauge with the pointer pointing in the measuring direction and turned so that the ball link is directed to where the column (item 2) is to be placed.
7. If the pin has a centre hole G 3/4", the magnetic base (item 5) must first be fitted in the hole and then the dial gauge placed on the magnetic base. The reason for this is that the magnetic base of the dial gauge will not "stick" if placed directly on top of the centre hole.
8. Place the column (item. 2) on the bearing lug of the pin and lock the bottom locking sleeve (item 3) in a position where its sharp edge coincides with the centre height of the dial gauge pointer.
9. Pull the ball link (item 4) through the column slit and lock it between the upper and lower locking sleeve. Stretch the ball link so much that the pointer of the dial gauge is in the middle of the measuring range.
10. Move the machine parts in a suitable way, so that the play can be read off on the gauge.

Document Title: Recommendations for cleanliness when working on hydraulic systems	Function Group: 170	Information Type: Service Information	Date: 3/26/2026
Profile:			

Recommendations for cleanliness when working on hydraulic systems



When working on the hydraulic system of the machine, avoid contact with leaking hydraulic oil under pressure. Also avoid contact with hot hydraulic oil.

It is very important to keep the hydraulic system free from impurities, as these can cause abnormal wear and can lead to operation interruptions, which in turn means increased costs for service and repairs. In spite of the built-in filters in the system, the greatest cleanliness should be exercised when handling hydraulic components, oils and fluids.

NOTE!

When works are carried out on the hydraulic system the use of a vacuum pump is recommended.

The recommendations are grouped under the following headings:

1. Repairing hydraulic components in a workshop.
2. Work on hydraulic system carried out in a workshop.
3. Work carried out on hydraulic system on site.
4. Storing and transporting hydraulic components.
5. Storing and handling hydraulic oil.

1. Repairing hydraulic components in a workshop

- Work on hydraulic components should be carried out separately from other workshop activities in a "so - called" clean room. The room should be well ventilated and the floor coated with an adherent (to dust) material. Machining, grinding etc must not be done in the "clean room".
- The work place should be equipped with thoroughly cleaned tools and suitable vessel for cleaning of hydraulic components. Avoid the use of adjustable spanners and wrenches.
- A vessel used for cleaning hydraulic components must not be used for cleaning anything else. The vessels should be cleaned often and new cleaning solution filled. The vessels should be equipped with a grating, to separate components from any sludge at the bottom.
- Components handled in the "clean room" should always be prewashed first. Lye solutions or similar which cause rusting must not be used as a cleaning agent.
- Work on the hydraulic system should always be planned so that it can be completed without delay.
- When cleaning parts while repairing, dry and clean compressed air should be used for drying, not cotton waste or rags. A low-pressure nozzle should preferably be used.
- When the repair of component has been completed, the components should always be plugged with clean plastic plugs of suitable size after which the component should be wrapped up.
- When cleaning the "clean room" a cleaning method should be used which does not stir up the dust and dirt.
- Hands and clothes should always be free from dirt.

2. Work on hydraulic system carried out in a workshop

- The machine should be cleaned before it is taken into the workshop.
- The work place should be thoroughly tidied and the tools thoroughly cleaned and free from burrs.
- The machine should be screened from other machines or work places where welding or grinding is carried out. Any place where the hydraulic system is opened should be thoroughly cleaned and protected with plastic sheeting.
- The openings in components removed from the machine and those left open on the machine should be immediately plugged. The components should be placed in suitable containers wrapped in plastic sheeting. No welding may be carried out on the machine because of fire hazard when the hydraulic system has been opened.
- The components removed from the machine, which are to be repaired, should be cleaned before they are taken

into the "clean room".

- Oil drained from the machine should be filled into a vessel intended for waste oil and this oil should not normally be re-used.
- If the tank is to be emptied and the oil on visual inspection or testing is found to be free from discolouration and impurities, fill the oil into a clean vessel which is then sealed. Refilling of this oil or filling with new oil should always be done with the hand pump on the machine.
- When refitting a component, the part of the machine where it is to be fitted should be thoroughly cleaned and inspected. In cases of frequent breakdowns and highly contaminated oil and components, pipes, hoses and valves should be flushed through and blown clean.
- Hands and clothes should always be free from dirt.

3. Work on hydraulic system carried out on site

- When necessary and if possible the machine should be moved to as dust-free an environment as possible. Or, as an alternative, the machine should be screened off with plastic sheeting or similar.
- A thorough trouble shooting should be carried out to eliminate unnecessary work. Test the movements of the hydraulic functions, check pressures and engine speed and listen. Adjustable spanners or wrenches should not be used when working on the hydraulic system. When the trouble has been traced, the place of approach should be cleaned and plastic sheeting placed so that it protects against dirt.
- Exchange components should be used to avoid repairs on site.
- Openings on components removed from the machine and all openings left open on the machine should be immediately plugged. Components removed from the machine should be wrapped in plastic sheeting and placed in suitable containers. Components which are to be re-fitted should be stored fitted with protective plugs and kept in plastic foil in plastic containers.
- Oil drained from the machine should be poured into vessels intended for waste oil and this oil should normally not be re-filled.
- If the tank is to be drained and the oil is found to be reusable, it should be drained into a clean vessel which is then sealed. Always use the hand pump on the machine when refilling oil or filling new oil.
- Always use a suitable cleaning solution which should be poured into a thoroughly clean vessel.
- Working clothes and hands should always be clean from dirt. If you have to climb onto the machine make sure your shoes are thoroughly clean.
- After each completed operation the tools should be thoroughly cleaned and deburred if needed.

4. Storing and transporting hydraulic components

- All hydraulic components should be stored in plastic bags or plastic sheeting and should be plugged. The wrapping should not be opened before the component is about to be used.
- Service vans should be fitted out and equipped in a way which facilitates order and cleanliness.
- Components which are too large to fit into the plastic containers should not be transported in the service vans but carried on a trailer instead.
- Each service van should carry a roll of plastic sheeting, plastic plugs of the most common sizes and types and plastic containers for components. Plugs and plastic sheeting should be of the disposable type.

5. Storing and handling hydraulic oil

- The hydraulic oil should be stored either in tanks or drums which can be sealed. The place where the oil is drained from the storage containers should not be near where machining or welding is carried out.
- All filling with oil should be done with the hand pump of the machine.
- Before filling, always check the new oil for contamination by water or other impurities. Carry out a visual check of the oil poured into a glass.
- A container used for transporting hydraulic oil should only be used for this purpose. The vessel should be marked and cleaned often.
- At the slightest suspicion of contamination, samples should be taken and sent away for analysis. Always clean the hydraulic oil immediately if the result of the analysis suggests this or if major work has been carried out on the hydraulic system.
- Only clean the tank if a layer of dirt has been deposited on the bottom of the tank. Otherwise flushing through is sufficient. The suction line should always be closed before cleaning is done by the use of a suitable cleaning agent.

Document Title: A few simple safety rules when servicing	Function Group: 191	Information Type: Service Information	Date: 3/26/2026
Profile:			

A few simple safety rules when servicing

The rules for operating the machine are given in the Operator's Instruction Manual. Read the following text for what must be done before you sit in the operator's seat to operate the machine and what must be done before and during the service of the machine.

A few important rules:

Read all signs and instructions which are fitted onto the machine and which are given in the Operator's Instruction Manual before you begin to service the machine. Each of the instructions contains important information about the handling and servicing of the machine.



Figure 1

- Always wear a hard hat, safety glasses, gloves, protective shoes and other protective articles when the work demands it. Before starting the engine indoors, make sure that the ventilation is sufficient to cope with the exhaust gases
- Carry out all checks which are prescribed. See the Operator's Instruction Manual under heading "How to start"..



Figure 2

NOTE!

Product: EW200 Volvo Excavator Service Manual

Full Download: <https://www.arepairmanual.com/downloads/ew200-volvo-excavator-service-manual/>
The machine should be in service position A when the checks are carried out.

- Make a control lamp test before starting the engine. Turn the ignition key to position I, see the Operator's Instruction Manual. If the alarm lamp flashes, the machine must **NOT BE STARTED** until the fault has been rectified.
- If the horn begins to sound: **SWITCH OFF THE CURRENT IMMEDIATELY WITH THE IGNITION KEY!** The warning is triggered because the flap valve in the suction line for the pumps is closed.
- Never drive the machine while under influence of alcohol, medicine or other drugs.
- When you are entering or leaving the machine, always face the machine and use the steps and handles. Always use both hands and one foot or both feet and one hand. Do not jump!
- No work must be carried out on the machine until you have acquired the appropriate knowledge of the machine to do the work.
- Park the machine in service position A before carrying out any work on the hydraulic system. The hydraulic system can be highly pressurised in parts even if the engine is turned off. Take extra care when opening the system between valve and hydraulic cylinder or hydraulic motor.
- Service work which is not carried out in the correct way is dangerous. Make sure you have sufficient knowledge, correct information, correct tools and correct equipment to carry out the service in a correct way. Repair or change broken tools and equipment.
- Always stop the engine before servicing the machine unless otherwise instructed on signs or in service literature.
- When changing oil in the engine, hydraulic system or gearbox, remember that the oil may be hot and could cause burns.
- Make sure that handles and stepping surfaces on ladders and other parts of the machine are free from oil, dirt or ice.
- Never wear loose-fitting clothing, a scarf or jewelry, which can get caught and cause injury, when working on the machine.
- When carrying out service work on the undercarriage, the slew brake should be applied and the digging equipment lowered with the bucket resting on firm ground.
- If the undercarriage is raised with the aid of the digging equipment, stabilators or dozer blade safe supports should be placed under the raised part of the machine before any person is allowed into the dangerous area under the machine.



Figure 3

- No persons are allowed under the digging equipment when it is lifted.
- Do not drive any shafts or pivot pins out of the digging equipment without having first safely supported the parts involved or suspended them from approved and correctly dimensioned lifting equipment.

Sample manual. Download All 187 pages at:

<https://www.arepairmanual.com/downloads/ew200-volvo-excavator-service-manual/>