

Document Title: <b>Complete machine, descriptions</b>	Function Group: <b>000</b>	Information Type: <b>Service Information</b>	Date: <b>3/24/2026</b>
Profile: <b>EW160E Volvo</b>			

## Complete machine, descriptions

Showing Selected Profile

Valid for serial numbers			
Model	Production site	Serial number start	Serial number stop
EW160E Volvo			

The machine is a wheeled excavator with a 360 degree swing movement.

### Engine

The machine is equipped with a straight six cylinder, four-stroke, turbocharged diesel engine with direct injection and charge air cooler.

The engine meet US Tier 4 final and California Tier 4 final emission requirements and EU Stage IV emission requirements.

See [Engine, description](#).

### Exhaust aftertreatment system

The engine features an exhaust aftertreatment system (EATS) in the form of two mufflers. The first one contains a diesel oxidation catalyst (DOC) and a diesel particulate filter (DPF) to reduce emissions of particulate matter (PM). The second one contains a selective catalytic reduction catalyst (SCR) to reduce nitrogen oxide (NOx) emissions.

The SCR uses diesel exhaust fluid, called AdBlue® or diesel exhaust fluid (DEF), to reduce the NOx emissions. An AdBlue®/DEF injection system is used to add this fluid to the exhaust.

See [Exhaust aftertreatment system, description](#).

### Electrical system

The machine is equipped with the Volvo CEA2+ (Common Electronic Architecture 2+) electrical system, a computerized monitoring and control system. The different control units are communicating via bus systems.

See [Electrical system, description](#).

See [Electronic control system, description](#).

### CareTrack

The machine is equipped with CareTrack, a telematics system developed by Volvo Construction Equipment. The system stores machine data, e.g., machine position, operating hours, fuel consumption, fuel level, that can be sent by wireless transmission to a computer.

CareTrack is available in different versions, depending on the required information level.

See [CareTrack W-ECU, description](#).

### Power Train

The machine is driven by a hydraulic drive motor with a variable displacement.

See [Travel motor \(electric proportional control\), description](#).

The travel gearbox has two hydraulically controlled gears. It is a so-called Powershift gearbox, which means that shifting is possible on the move.

The brakes for gear shifting are applied automatically with spring force and released with servo pressure. The parking brake is integrated in the gearbox and uses the gearbox brake discs, which are applied by spring force.

See [Travel gearbox, description](#).

The drive axles are equipped with a differential, planetary gear hub reductions and wet multi-disc brakes.

See [Front axle, description](#).

See [Rear axle, specification](#).

### Swing system

Sample manual. Download All 4879 pages at:

<https://www.arepairmanual.com/downloads/ew160e-volvo-excavator-service-manual/>

Product: EW160E Volvo Excavator Service Manual

Full Download: <https://www.arepairmanual.com/downloads/ew160e-volvo-excavator-service-manual/>

The swing movement of the machine is performed by a directacting motor with integrated swing brake.

EW180E

The swing movement of the machine is performed by a motor with gearbox to reduce the speed and increase the torque.

See [Swing motor, description](#).

The swing pinion drives against a swing ring with internal ring gear. The swing ring connects the superstructure with the undercarriage.

A centre passage connects the superstructure and undercarriage hydraulically and electrically.

### **Brake system**

The brake system is a dual-circuit system with two accumulators, operated via the servo hydraulics.

The service brakes are servo-hydraulically operated, selfadjusting, wet, multi-disc brakes in two separate brake circuits.

The service brake pedal is also used as digging brake.

The parking brake is a negative action wet disc brake integrated in the travel gearbox. It is spring applied and pressure released.

See [Hydraulic brake system, description](#).

### **Steering system**

The machine is provided with a hydrostatic steering system.

See [Steering system, description](#).

### **Cab**

The cab is equipped with an automatically controlled heating and air conditioning system with defroster system for the windows and an ergonomic operator's seat.

See [HVAC system](#).

The cab is approved as a protective cab according to FOPS (Falling Object Protective Structure) and ROPS (Roll Over Protective Structure) – standards.

If any part of the cab's protective structure is affected by plastic deformation or failures, the cab shall be replaced immediately.

Never make any unauthorized changes to the cab, e.g., lowering the roof height, drilling, welding of brackets for fire extinguishers, radio antenna, or other equipment without first discussing the change with Volvo, via a dealer. Volvo decides if the change can lead to nullification of the approval.

### **Hydraulic system**

The machine has a load independent flow sharing hydraulic system which always ensures that each movement receives oil according to the demand and no function stops.

The diesel engine drives the machine's working pump, which gives hydraulic oil flow to the working hydraulics and the travel motor.

The double gear pump is mounted behind the working pump and supplies the servo, brake and steering hydraulics.

See [Description, general](#).

### **Equipment**

Different combinations of boom, dipper arm and attachments can be offered. This manual describes the most common standard alternatives.

Sample manual. Download All 4879 pages at:

<https://www.arepairmanual.com/downloads/ew160e-volvo-excavator-service-manual/>

Document Title: <b>Product identification plates</b>	Function Group: <b>000</b>	Information Type: <b>Service Information</b>	Date: <b>3/24/2026</b>
Profile: <b>EW160E Volvo</b>			

## Product identification plates

Showing Selected Profile

Valid for serial numbers			
Model	Production site	Serial number start	Serial number stop
EW160E Volvo			

When ordering spare parts, and in all telephone enquiries or correspondence the model designation and the Product Identification Number (PIN) must always be quoted.

### Product plate

The product plate on the machine shows the manufacturer's name and address, model designation, Product Identification Number (PIN), machine weight, engine output and the manufacturing year.

### Engine product plate

The engine product plate contains type designation, part number, serial number and is positioned on the engine.

### Travel gearbox product plate

The travel gearbox product plate contains type designation, part number, serial number and is positioned on the travel gearbox.

### Axle product plate

The axle product plate contains type designation, part number, serial number and is positioned on each axle.

### Swing gearbox

The swing gearbox product plate contains type designation, part number, serial number and is positioned on the swing gearbox.

### Main pump

The main pump product plate contains type designation, part number, serial number and is positioned on the main pump.

### Main control valve

The main control valve product plate contains type designation, part number, serial number and is positioned on the main control valve.

### Cab

The cab product plate contains cab type, type approval, part number, serial number and is positioned on the left side in the cab.

Document Title: <b>Machine view</b>	Function Group: <b>000</b>	Information Type: <b>Service Information</b>	Date: <b>3/24/2026</b>
Profile: <b>EW160E Volvo</b>			

## Machine view

Showing Selected Profile

Valid for serial numbers			
Model	Production site	Serial number start	Serial number stop
EW160E Volvo			

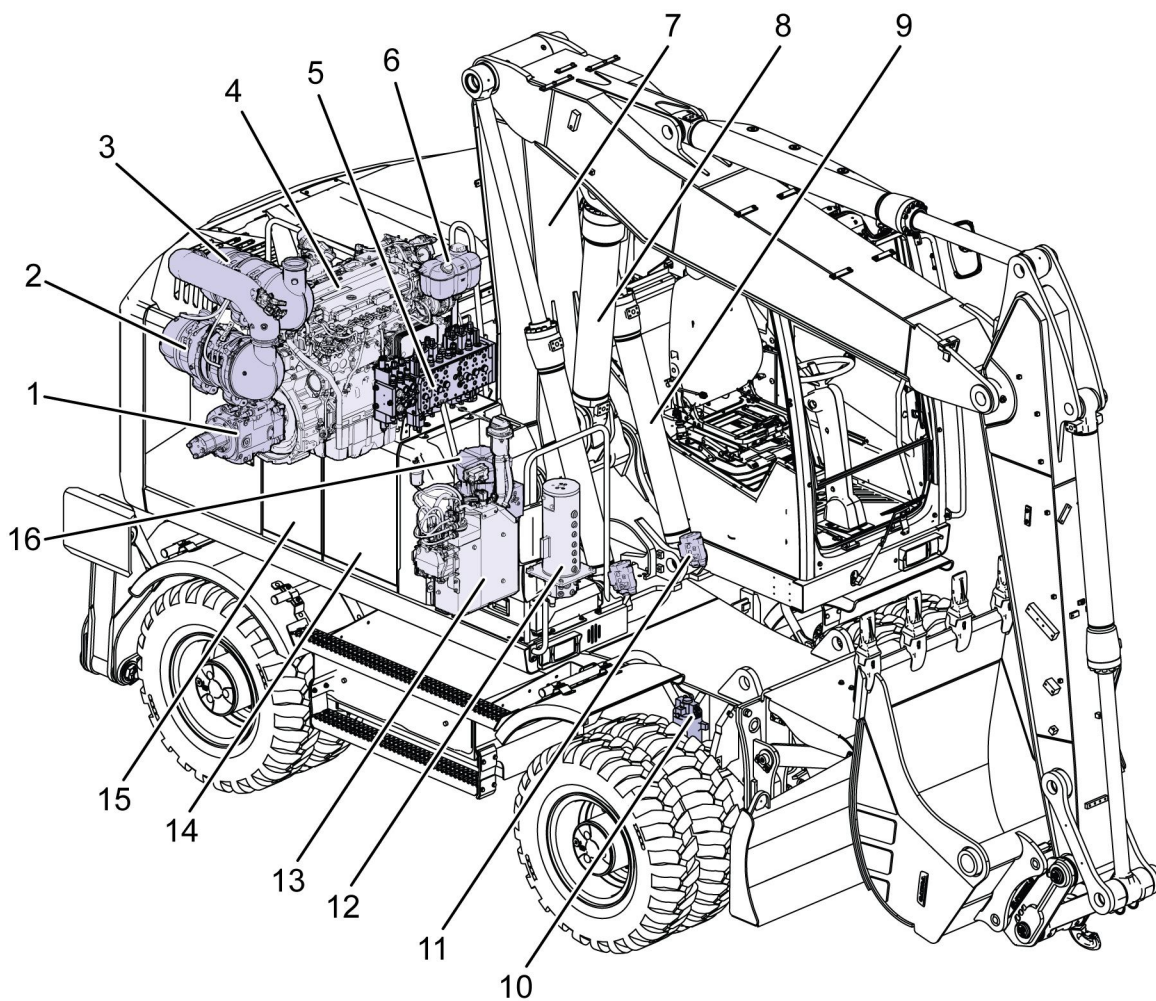

V1148953

**Figure 1**  
Main component locations

1	Main pump	9	Boom cylinder
2	DPF muffler (diesel particulate filter)	10	Pivot axle locking cylinder
3	SCR muffler (selective catalytic reduction catalyst)	11	Line rupture valve
4	Engine	12	Center passage
5	Main control valve	13	AdBlue®/DEF tank

- |   |                      |    |                    |
|---|----------------------|----|--------------------|
| 6 | Expansion tank       | 14 | Fuel tank          |
| 7 | First boom           | 15 | Hydraulic oil tank |
| 8 | Second boom cylinder | 16 | Swing unit         |

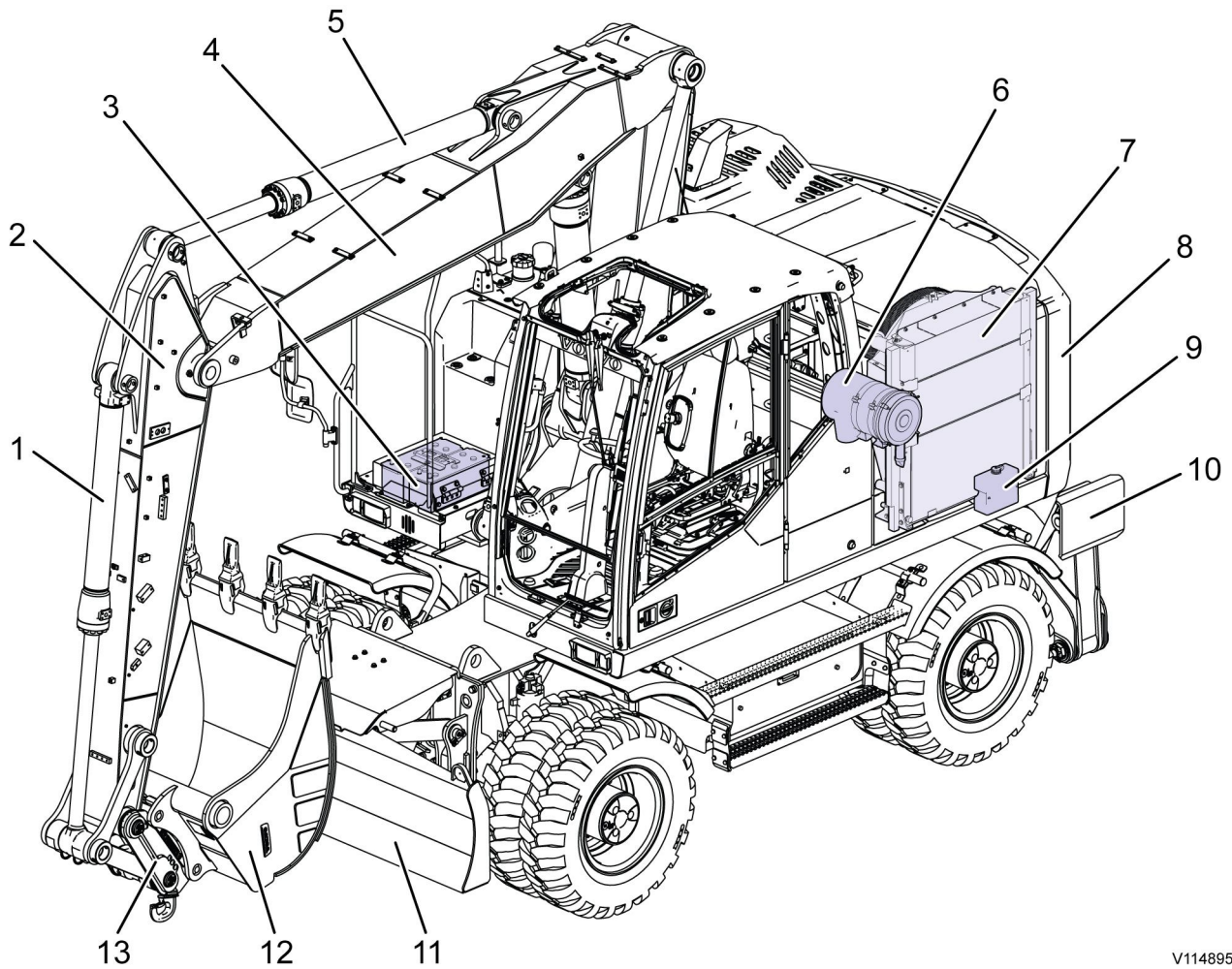

V1148954

**Figure 2**  
Main component locations

- |   |                                |    |                              |
|---|--------------------------------|----|------------------------------|
| 1 | Bucket cylinder                | 8  | Counterweight                |
| 2 | Dipper arm                     | 9  | Windscreen washer water tank |
| 3 | Batteries                      | 10 | Stabilizer                   |
| 4 | Second boom                    | 11 | Stabilizer blade             |
| 5 | Dipper arm cylinder            | 12 | Bucket                       |
| 6 | Engine air cleaner             | 13 | Quick coupler                |
| 7 | Radiator and charge air cooler |    |                              |

Document Title: <b>Measurement conversion tables</b>	Function Group: <b>030</b>	Information Type: <b>Service Information</b>	Date: <b>3/24/2026</b>
Profile: <b>EW160E Volvo</b>			

## Measurement conversion tables

Showing Selected Profile

Valid for serial numbers			
Model	Production site	Serial number start	Serial number stop
EW160E Volvo			

### Length

Unit	cm	m	km	in	ft	yd	mile
cm	1	0.01	0.00001	0.3937	0.03281	0.01094	0.000006
m	100	1	0.001	39.37	3.2808	1.0936	0.00062
km	100000	1000	1	39370.7	3280.8	1093.6	0.62137
in	2.54	0.0254	0.000025	1	0.08333	0.02777	0.000015
ft	30.48	0.3048	0.000304	12	1	0.3333	0.000189
yd	91.44	0.9144	0.000914	36	3	1	0.000568
mile	160930	1609.3	1.6093	63360	5280	1760	1

1 mm = 0.1 cm - 1 mm = 0.001 m

### Area

Unit	cm <sup>2</sup>	m <sup>2</sup>	km <sup>2</sup>	a	ft <sup>2</sup>	yd <sup>2</sup>	in <sup>2</sup>
cm <sup>2</sup>	1	0.0001	-	0.000001	0.001076	0.000012	0.155000
m <sup>2</sup>	10000	1	0.000001	0.01	10.764	1.1958	1550.000
km <sup>2</sup>	-	1000000	1	10000	1076400	1195800	-
a	0.01	100	0.0001	1	1076.4	119.58	-
ft <sup>2</sup>	-	0.092903	-	0.000929	1	0.1111	144.000
yd <sup>2</sup>	-	0.83613	-	0.008361	9	1	1296.00
in <sup>2</sup>	6.4516	0.000645	-	-	0.006943	0.000771	1

1 ha = 100 a - 1 mile<sup>2</sup> = 259 ha = 2.59 km<sup>2</sup>

### Volume

Unit	cm <sup>3</sup> = cc	m <sup>3</sup>	l	in <sup>3</sup>	ft <sup>3</sup>	yd <sup>3</sup>
cm <sup>3</sup> = ml	1	0.000001	0.001	0.061024	0.000035	0.000001
m <sup>3</sup>	1000000	1	1000	61024	35.315	1.30796
dm <sup>3</sup> (l)	1000	0.001	1	61.024	0.035315	0.001308
in <sup>3</sup>	16.387	0.000016	0.01638	1	0.000578	0.000021
ft <sup>3</sup>	28316.8	0.028317	28.317	1728	1	0.03704
yd <sup>3</sup>	764529.8	0.76453	764.53	46656	27	1

1 gal (US) = 3785.41 cm<sup>3</sup> = 231 in<sup>3</sup> = 0.83267 gal (UK)

## Weight

Unit	g	kg	t	oz	lb
g	1	0.001	0.000001	0.03527	0.0022
kg	1000	1	0.001	35.273	2.20459
t	1000000	1000	1	35273	2204.59
oz	28.3495	0.02835	0.000028	1	0.0625
lb	453.592	0.45359	0.000454	16	1

1 ton (metric) = 1.1023 ton (US) = 0.9842 ton (UK)

## Pressure

Unit	kp/cm <sup>2</sup>	bar	Pa=N/m <sup>2</sup>	kPa	lbf/in <sup>2</sup>	lbf/ft <sup>2</sup>
kp/cm <sup>2</sup>	1	0.98067	98066.5	98.0665	14.2233	2048.16
bar	1.01972	1	100000	100	14.5037	2088.6
Pa=N/m <sup>2</sup>	0.00001	0.001	1	0.001	0.00015	0.02086
kPa	0.01020	0.01	1000	1	0.14504	20.886
lbf/in <sup>2</sup>	0.07032	0.0689	6894.76	6.89476	1	144
lbf/ft <sup>2</sup>	0.00047	0.00047	47.88028	0.04788	0.00694	1

kg/cm<sup>2</sup> = 735.56 Dry (mmHg) = 0.96784 atm

## Unit explanations

Unit	abbreviation
Newton meter	Nm
Kilopoundmeter	kpm
Kilopascal	kPa
Megapascal	MPa
Kilowatt	kW
kilojoule	kJ
British thermal unit	Btu
Calorie	ca

## Approx. conversion

SI unit	Conversion factor	Non SI	Conversion factor	SI
<b>Torque</b>				
Nm	x10.2	=kg/cm	x0.8664	=lb in
Nm	x0.74	=lbf-ft	x1.36	=Nm
Nm	x0.102	=kg/m	x7.22	=lbft
<b>Pressure (Pa = N/m<sup>2</sup>)</b>				
kPa	x4.0	=in.H <sub>2</sub> O	x0.249	=kPa
kPa	x0.30	=in.Hg	x3.38	=kPa
kPa	x0.145	=psi	x6.89	=kPa
bar	x14.5	=psi	x0.069	=bar
kp/cm <sup>2</sup>	x14.22	=psi	x0.070	=kp/cm <sup>2</sup>
N/mm <sup>2</sup>	x145.04	=psi	x0.069	=bar
MPa	x145	=psi	x0.00689	=MPa
<b>Power (W = J/s)</b>				

kW	x1.36	=hp(cv)	x0.736	=kW
kW	x1.34	=bhp	x0.746	=kW
kW	x0.948	=Btu/s	x1.055	=kW
W	x0.74	=ft.lb/s	x1.36	=W
Energy (J = Nm)				
kJ	x0.948	=Btu	x1.055	=kJ
J	x0.239	=calorie	x4.19	=J
Speed and acceleration				
m/s <sup>2</sup>	x3.28	=ft/s <sup>2</sup>	x0.305	=m/s <sup>2</sup>
m/s	x3.28	=ft/s	x0.305	=m/s
km/h	x0.62	=mph	x1.61	=km/h
Horsepower/torque				
Bhp x5252 rpm= TQ (lb-ft)			TQ x rpm 5252=bhp	
Temperature				
°C =(°F-32)/1.8			°F =(°C x1.8) +32	
Flow factor				
l/min (dm <sup>3</sup> /min)	x0.264	= US gal/min	x3.785	=liter/min

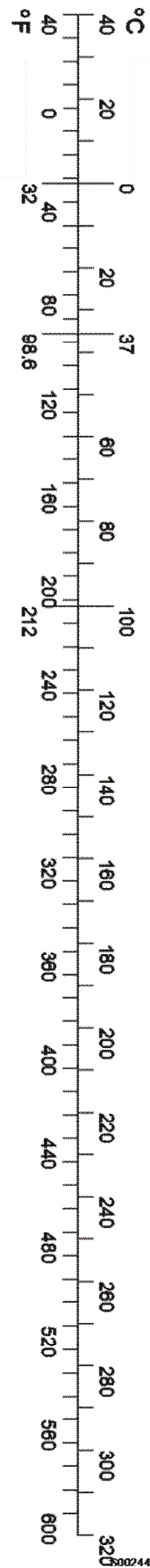

Figure 1

Document Title: <b>Tightening torques</b>	Function Group: <b>030</b>	Information Type: <b>Service Information</b>	Date: <b>3/24/2026</b>
Profile: <b>EW160E Volvo</b>			

## Tightening torques

Showing Selected Profile

Valid for serial numbers			
Model	Production site	Serial number start	Serial number stop
EW160E Volvo			

### Wheel nuts

Wheel nuts		
		
Thread M	Wrench size (width across flats)	Tightening torque (Nm)
M22 x 1.5	30	500 +/- 25

### Hydraulic connections, general

Before fitting pipe couplings, plugs and hoses:

- Make sure that the sealing surfaces are clean and free from pores or scratches.
- Check elastic seal rings for defects.
- Oil in threads, sealing surfaces and contact surfaces except for ORFS-connections (ORFS = O-Ring Face Seal).

### Valve connections

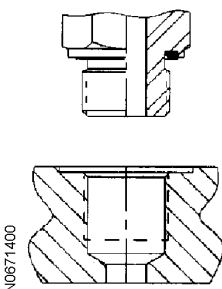
Valve connections, ORFS-connections with ED seals (DIN 3852 form E)		
		
Connection thread (mm)	Wrench size, width across flats (mm)	Tightening torque (Nm)
M10 x 1.0		19
M12 x 1.5	17	37
M14 x 1.5	22	58
M16 x 1.5	22	74
M18 x 1.5	24	94
M20 x 1.5		130
M22 x 1.5	27	140
M27 x 2.0	32	190
M33 x 2.0	41	330

M42 x 2.0	50	470
M48 x 2.0	55	570
<b>Connection thread (inches)</b>	<b>Wrench size, width across flats (mm)</b>	<b>Tightening torque (Nm)</b>
G 1/8	17 alt. 19	19
G 1/4	19 alt. 22	58
G 3/8	22 alt. 27	84
G 1/2	27 alt. 32	120
G 3/4	32 alt. 41	190
G 1	41 alt. 46	330
G 1 1/4	50	470
G 1 1/2	55	570

**Valve connections, ORFS-connections with O-ring seals (ISO 6149)**

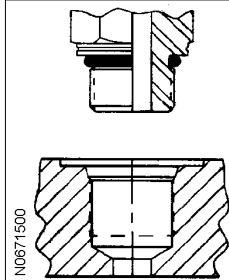

Connection thread (mm)	Wrench size, width across flats (mm)	Tightening torque (Nm)
M8 x 1.0		11
M10 x 1.0		21
M12 x 1.5	17 alt. 19	37
M14 x 1.5	19 alt. 22	47
M16 x 1.5	22	58
M18 x 1.5	24 alt. 27	74
M22 x 1.5	27 alt. 32	110
M27 x 2.0	32	180
M33 x 2.0	32, 41 alt. 46	330
M42 x 2.0	50	350
M48 x 2.0	55	440
<b>Connection thread (inches)</b>	<b>Wrench size, width across flats (mm)</b>	<b>Tightening torque (Nm)</b>
7/16 – 20 UNF	16	21
1/2 – 20 UNF		26
9/16 – 18 UNF	19	37
3/4 – 16 UNF	22	74
7/8 – 14 UNF	27	110
1 1/16 – 12 UNF	41	180
1 5/16 – 12 UNF	41	284
1 5/8 – 12 UNF	50	300
1 7/8 – 12 UNF	55	390

**Blanking plugs**

**Blanking plugs with ED seal**



Connection thread (mm)	Allen key dim. (mm)	Tightening torque (Nm)
M10 x 1.0	5	12
M12 x 1.5	6	25
M14 x 1.5	6	35
M16 x 1.5	8	55
M18 x 1.5	8	65
M20 x 1.5	10	80
M22 x 1.5	10	90
M26 x 1.5	12	100
M27 x 2.0	12	140
M33 x 2.0	17	230
M42 x 2.0	22	360
M48 x 2.0	24	360
Connection thread (inches)	Allen key dim. (mm)	Tightening torque (Nm)
G 1/8	5	13
G 1/4	6	30
G 3/8	8	60
G 1/2	10	80
G 3/4	12	140
G 1	17	200
G 1 1/4	22	400
G 1 1/2	24	450

#### Blanking plugs with O-ring seal (ISO 6149)

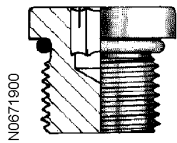

Connection thread (mm)	Allen key dim. (mm)	Tightening torque (Nm)
M10 x 1.0	5	20
M12 x 1.5	6	35
M14 x 1.5	6	45
M16 x 1.5	8	55
M18 x 1.5	8	70
M20 x 1.5	10	80
M22 x 1.5	10	100
M26 x 1.5	12	130
M27 x 2.0	12	170
M33 x 2.0	14	310
M42 x 2;0	22	330

#### ORFS-connections

##### ORFS-connections (ISO 8434-3)

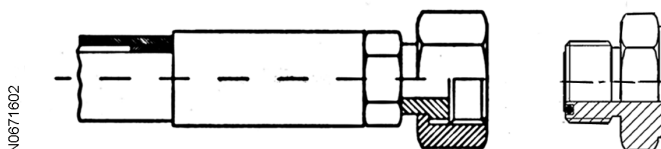

Thread (inches)	Wrench size, width across flats (mm)	Tightening torque (Nm) *
-----------------	--------------------------------------	--------------------------

9/16 – 18 UNF	17 alt. 19	25
11/16 – 16 UN	22	35
13/16 – 16 UN	24	55
1 – 14 UNS	30	85
1 3/16 – 12 UN	36	120
1 7/16 – 12 UN	41 alt. 46	160
1 11/16 – 12 UN	50	200
2 – 12 UN	60	260

\* Threads and sealing surface must not be oiled in before tightening.

### Hose clamps

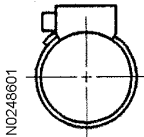
Hose clamps with worms		
		
Intended for hose outside diameter (mm)	Wrench size, width across flats (mm)	Tightening torque (Nm)
10 – 19	7	2.5
20 – 30	7	3.5
31 – 49	7	4.5
50 – 231	7	5.5

### Bolts and nuts

The pretensioning force achieved at a given tightening torque depends on the coefficient of friction of the bolted joint. The coefficient of friction in turn depends on the surface texture, surface treatment and lubricated condition. The values are calculated assuming a coefficient of friction of 0.2 for a dry chromated flange bolt and 0.15 for a lubricated chromated flange bolt. The lower torque for Allen bolts and traditional hex bolts, in relation to flange bolts, is due to the shorter torque arm for the frictional force under the bolt head (smaller diameter of bolt head).

The following abbreviations for surface treatment are used in the tables:

- Fe/Zn-Fe = Black chromated zinc - iron
- FZB = Blank chromated

#### NOTE!

In some body parts, there are weld bolts with much lower strength than normal bolts of the same dimension.

#### NOTE!

When Nordloc washer is used, increase the torque by 20%.

#### NOTE!

Bolts provided with liquid alt. micro-capsuled thread locker or thread sealant shall be tightened with the same torque as a lubricated bolt of the same type.

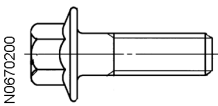
Flange bolts						
						Blind rivet nut
Thread (mm)	Wrench size, width across flats (mm)	Torque (Nm)				Torque (Nm)
		8.8 Fe/Zn-Fe Dry	8.8 Fe/Zn-Fe Lubricated	10.9 Phosphated	10.9 Phosphated Lubricated	Dry

M5	8	7	6			6
M6	10	12	10			10
M8	12	28	24			24
M10	14	56	48	70	60	48
M12	17	100	85	125	105	82
M14	18	160	140	200	175	
M16	21	250	220	320	275	

Hex bolts and Allen head bolts								Blind rivet nut
Thread (mm/inch)	Wrench size (width across flats)		Torque (Nm)				Torque (Nm) Dry	
	Hex bolt (mm/inch)	Allen head bolt (mm/inch)	8.8 FZB & Fe/Zn-Fe Dry	8.8 FZB & Fe/Zn-Fe Lubricated	10.9 Phosphated Lubricated	12.9 Untreated Lubricated		
M5	8	4	6	5			6	
M6	10	5	10	9		20	10	
M8	13	6	25	22		40	24	
M10	16	8	50	44	60	80	48	
M12	18	10	90	75	105	140	82	
M14	21	12	140	125	175	220		
M16	24	14	220	190	275	340		
M20	30	17	450	380	540	650		
M24	36	19	770	660	900	1 120		
M27	41	–	1 100	940	1 350	1 620		
M30	46	22	1 500	1 280	1 840	2 210		
M36	55		2 500	2 300	3 210	3 850		
1/4 UNC	7/16	3/16	12	10	15	20		
5/16 UNC	1/2	1/4	25	21	30	40		
3/8 UNC	9/16	5/16	45	38	55	70		
7/16 UNC	5/8		65	55	90			
1/2 UNC	3/4	3/8	100	85	130	170		
9/16 UNC	13/16		145	123	190			

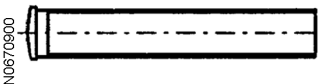
Nuts on weld bolts (material S235JRG2-EN 10025)	
	
Thread	Torque (Nm)
M6	5
M8	12

### Tolerances

Modern high-quality torque wrenches normally give a variation of  $\pm 5\%$  of the indicated value. This, together with variations in friction coefficient, gives a range in the pretensioning force of approximately  $\pm 16\%$  for lubricated bolted joints and  $\pm 29\%$

% for dry bolted joints.

Document Title: <b>Machine weights</b>	Function Group: <b>030</b>	Information Type: <b>Service Information</b>	Date: <b>3/24/2026</b>
Profile: <b>EW160E Volvo</b>			

## Machine weights

Showing Selected Profile

Valid for serial numbers			
Model	Production site	Serial number start	Serial number stop
EW160E Volvo			

### EW160E

EW160E with	Counterweight	Total machine weight incl. stabiliser blade front and stabiliser legs rear	Total machine weight incl. stabiliser blade rear	Total machine weight incl. stabiliser legs front and rear
5.0 m (16 ft 4.9 in) monoblock boom 2.45 m (8 ft 0.5 in) dipper arm Attachment bracket S6 530 kg / 750 l bucket	standard	17272 kg (38078 lb)	16202 kg (35719 lb)	17522 kg (38629 lb)
	heavy	17672 kg (38960 lb)	16602 kg (36601 lb)	17922 kg (39511 lb)
5.1 m (16 ft 8.8 in) two-piece boom 2.45 m (8 ft 0.5 in) dipper arm Attachment bracket S6 530 kg / 750 l bucket	standard	17608 kg (38819 lb)	16538 kg (36460 lb)	17858 kg (39370 lb)
	heavy	18008 kg (39701 lb)	16938 kg (37342 lb)	18258 kg (40252 lb)

EW160E HEC with	Counterweight	Total machine weight incl. stabiliser blade front and stabiliser legs rear	Total machine weight incl. stabiliser blade rear	Total machine weight incl. stabiliser legs front and rear
5.0 m (16 ft 4.9 in) monoblock boom 2.45 m (8 ft 0.5 in) dipper arm Attachment bracket S6 530 kg / 750 l bucket	standard	18201 kg (40126 lb)	17131 kg (37767 lb)	18451 kg (40677 lb)
	heavy	18601 kg (41008 lb)	17531 kg (38649 lb)	18851 kg (41559 lb)
5.1 m (16 ft 8.8 in) two-piece boom 2.45 m (8 ft 0.5 in) dipper arm Attachment bracket S6 530 kg / 750 l bucket	standard	18537 kg (40867 lb)	17467 kg (38508 lb)	18787 kg (41418 lb)
	heavy	18937 kg (41749 lb)	17867 kg (39390 lb)	19187 kg (42300 lb)

Document Title: <b>Specifications, weight</b>	Function Group: <b>030</b>	Information Type: <b>Service Information</b>	Date: <b>3/24/2026</b>
Profile: <b>EW160E Volvo</b>			

## Specifications, weight

Showing Selected Profile

Valid for serial numbers			
Model	Production site	Serial number start	Serial number stop
EW160E Volvo			

Machine	<a href="#">Machine weights</a>
---------	---------------------------------

Engine	<a href="#">Engine, specifications</a>
--------	--

Main pump	<a href="#">Hydraulic pump, specifications</a>
-----------	--

Fuel tank	<a href="#">Fuel tank, specifications</a>
-----------	---

Hydraulic oil tank	<a href="#">Hydraulic tank, specifications</a>
--------------------	--

Transmission, gearbox	<a href="#">Travel gearbox, specifications</a>
-----------------------	--

Swing motor	<a href="#">Swing motor, specifications</a>
-------------	---

Front axle, complete	<a href="#">Front axle, specification</a>
----------------------	---

Rear axle, complete	<a href="#">Rear axle, specification</a>
---------------------	--

Counterweight	<a href="#">Counterweight, specifications</a>
---------------	---

Swing ring gear	<a href="#">Swing ring gear, specifications</a>
-----------------	---

Cab	<a href="#">Cab, weight</a>
-----	-----------------------------

Operator seat	<a href="#">Cab, weight</a>
---------------	-----------------------------

Document Title: <b>Lifting instructions</b>	Function Group: <b>050</b>	Information Type: <b>Service Information</b>	Date: <b>3/24/2026</b>
Profile: <b>EW160E Volvo</b>			

## Lifting instructions

Showing Selected Profile

Valid for serial numbers			
Model	Production site	Serial number start	Serial number stop
EW160E Volvo			

### **WARNING**

Risk of personal injury.

Faulty or improper lifting equipment could cause the machine to break away from the lifting vehicle, causing accidents, serious injury or death.

**Use certified cables, lifting straps, slings, shackles and hooks with adequate load capacity and never lift the machine with a person in or on the machine.**

### **NOTE!**

Lift the machine on flat, even and level ground.

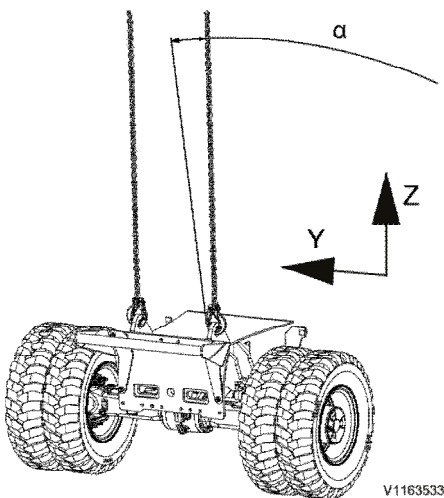

**Figure 1**

### **NOTE!**

Only use the lifting points intended for lifting and do not use the lifting eyes to lift more than the total machine weight.

1. Start the engine, and arrange the bucket, arm and boom as illustrated below.
2. Move the control lockout lever down to lock the system securely.
3. Stop the engine, check the safety around the machine.
4. Close and lock windows, doors and hoods securely.
5. Remove the covers from the lifting points on top of the counterweight.
6. Attach the lifting slings according to the decal on the right side of the cab.
7. At the beginning of the lift, check that the machine is level before continuing the lift.
8. Maintain good visibility of the machine at all times during the lift. And continuously check that the machine is level.

<b>Lifting</b>		
Direction	EW160E	EW180E
$F_{Res} / LC$ (daN)	5250 daN	5600 daN
Angle $\alpha_{max}$	15 °	15 °
$1000kg = 9810N = 981daN = 9,81kN$		
Load per device _ 4 devices are required for lifting		

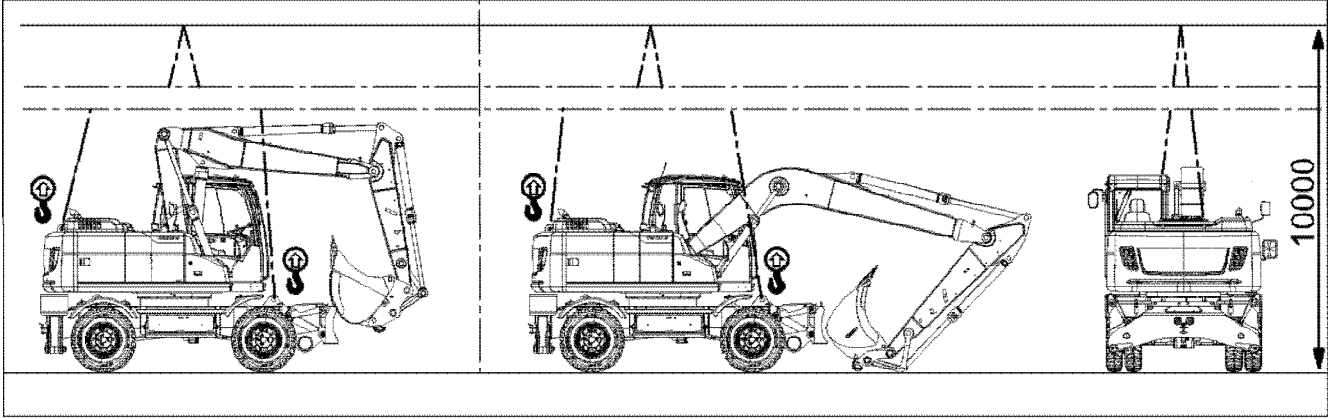

V1101213

Figure 2

Document Title: <b>Measurements before transporting machine</b>	Function Group: <b>050</b>	Information Type: <b>Service Information</b>	Date: <b>3/24/2026</b>
Profile: <b>EW160E Volvo</b>			

## Measurements before transporting machine

Showing Selected Profile

Valid for serial numbers			
Model	Production site	Serial number start	Serial number stop
EW160E Volvo			

### **NOTICE**

**The person in charge of the transport must see to that loading, positioning, lashing and transporting the machine on a trailer or other vehicle is done according to applicable laws and regulations for the country or state in question. For further information, contact your dealer.**

#### **Inspections and actions before transport:**

- Inspect lifting or tying-down attachment points on the machine and the trailer for wear and damage before transport and at each service. If they are worn or damaged they must be replaced before transport.
- Choose adequate lashing equipment according to the tables on the next pages.
- Inspect lashing equipment before use. If it shows signs of wear or damage it must not be used, replace it immediately.
- Check that the loading surface of the trailer is free of oil, dirt and ice.
- Clean the machine from mud and stones to avoid pollution on the road and damage on other vehicles.
- Fold down or remove antennas and the rotating beacon on the machine.
- Engage the pivot axle locking and swing brake on the machine before loading on the trailer, see operator's manual section: [Pivot axle locking](#).
- Lock all doors and covers on the machine.

Document Title: <b>Tying down machine</b>	Function Group: <b>050</b>	Information Type: <b>Service Information</b>	Date: <b>3/24/2026</b>
Profile: <b>EW160E Volvo</b>			

## Tying down machine

Showing Selected Profile

Valid for serial numbers			
Model	Production site	Serial number start	Serial number stop
EW160E Volvo			

Both the front and the rear of the undercarriage must be lashed down. Tie the machine down using attaching points. Links can be secured to the attachment at the arm or the bucket. The links must be thoroughly tightened, with, for example, turnbuckles. Blocks must be placed in front of and behind each wheel.

If the machine is equipped with an attachment bracket for the bucket, the bucket must be secured with a link between the lifting hook and the cutting edge of the bucket. Tension with a turnbuckle or similar, when the machine is transported on a trailer with stretched out attachment.

Other types of attachments are to be secured in a similar way or disassembled.

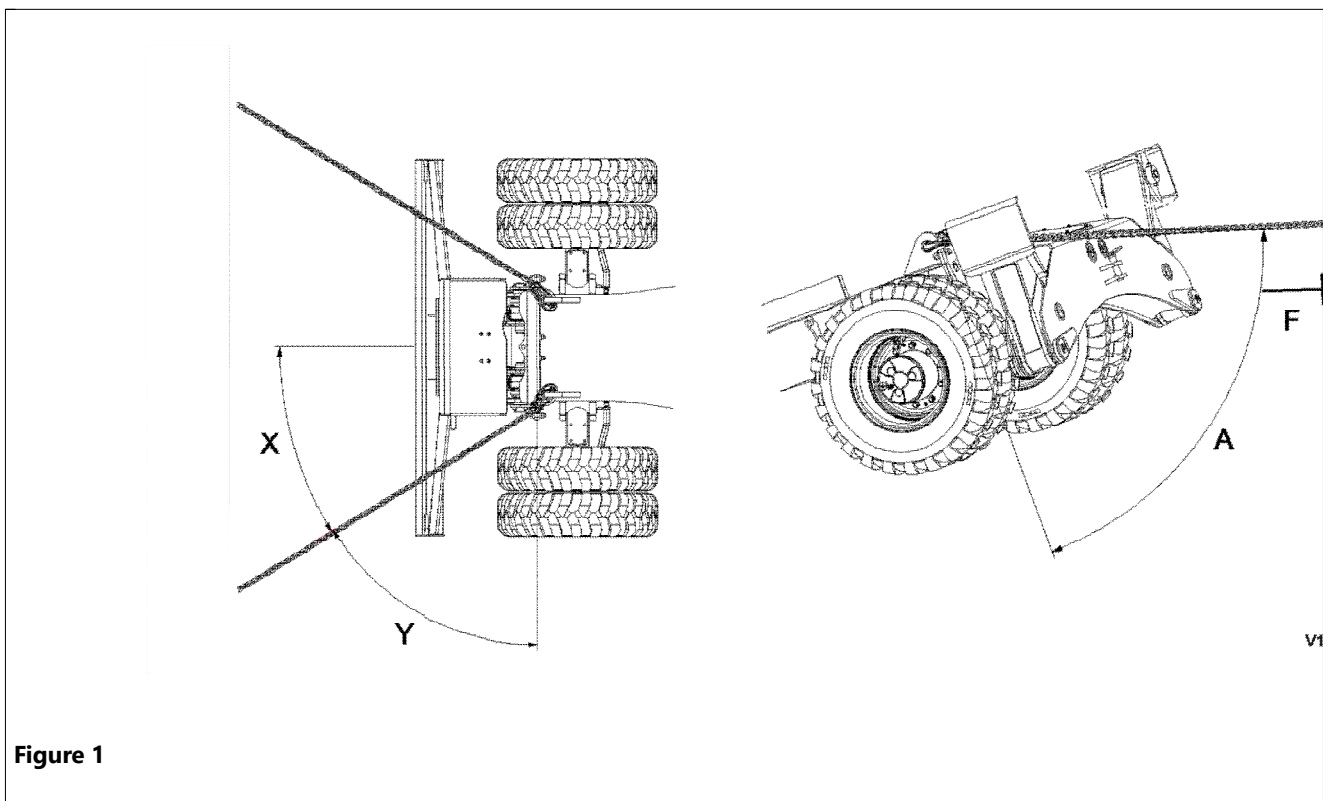

**Figure 1**

Tying down machine with outrigger		
Direction	EW160E	EW180E
$F_{Res}$	11850 daN	13850 daN
$F_z$	- 3050 daN	- 3550 daN
$F_x$	8950 daN	10400 daN
$F_y$	7150 daN	8350 daN

Angle <sub>Alpha A</sub>	75°	75°
Angle <sub>Beta X</sub>	39°	39°
Angle <sub>Beta Y</sub>	51°	51°

<b>Tying down machine with dozer blade / grab holder / nothing</b>		
Direction	EW160E	EW180E
F <sub>Res</sub>	13150 daN	15350 daN
F <sub>Z</sub>	- 6450 daN	- 7500 daN
F <sub>X</sub>	8950 daN	10400 daN
F <sub>Y</sub>	7150 daN	8350 daN
Angle <sub>Alpha A</sub>	61°	61°
Angle <sub>Beta X</sub>	39°	39°
Angle <sub>Beta Y</sub>	51°	51°

1000kg = 9810N = 981daN = 9,81kN
Load per device _ 2 devices of effective tying down attachment points to the direction of force 4 tying down devices are required _ Angle tolerance is + / - 2 %

<b>Temporary force on the towing hook on outrigger</b>		
Direction	EW160E	EW180E
F <sub>X</sub>	12300 daN	12300 daN
F <sub>Y</sub>	1000 daN	1000 daN
1000kg = 9810N = 981daN = 9,81kN		
Load on pull pin device.		

### Counterweight

When removing/installing counterweight – contact a workshop authorised by Volvo.



Risk of crushing injury or death.

The counterweight is a heavy machine part, incorrect handling could cause serious crushing injury or death.

**Never remove or install the counterweight by yourself, always contact your Volvo workshop.**

Document Title: <b>Operation numbers for additional work</b>	Function Group: <b>070</b>	Information Type: <b>Service Information</b>	Date: <b>3/24/2026</b>
Profile: <b>Excavators (EXC)</b>			

## Operation numbers for additional work

Showing Selected Profile

These operations can be used to identify work that is not included in the time guide or described in the methods in the Service Manual. When these operations are used, a description of the work that has been performed must be provided.

### Other work related to engine

Op. no. 070-210

This operation can be used when work has been done related to the engine and function group 2 when no applicable method description was available. When this operation is used, additional information is required:

- Description of work that has been done

### Other work related to electrical system

Op. no. 070-310

This operation can be used when work has been done related to the electrical system and function group 3 when no applicable method description was available. When this operation is used, additional information is required:

- Description of work that has been done

### Other work related to transmission, gearbox, travel motor, swing motor

Op. no. 070-410

This operation can be used when work has been done related to the transmission, gearbox, travel motor or swing motor and function group 4 when no applicable method description was available. When this operation is used, additional information is required:

- Description of work that has been done

### Other work related to drive axle

Op. no. 070-470

This operation can be used when work has been done related to the drive axle and function group 46 when no applicable method description was available. When this operation is used, additional information is required:

- Description of required work that have been done

### Other work related to brake system

Op. no. 070-510

This operation can be used when work has been done related to the brake system and function group 5 when no applicable

method description was available. When this operation is used, additional information is required:

- Description of work that has been done

**Other work related to steering system**

Op. no. 070-610

This operation can be used when work has been done related to the steering system and function group 6 when no applicable method description was available. When this operation is used, additional information is required:

- Description of work that has been done

**Other work related to frame link, axle suspension**

Op. no. 070-710

This operation can be used when work has been done related to the frame link, axle suspension and other parts related to function group 7 when no applicable method description was available. When this operation is used, additional information is required:

- Description of work that has been done

**Other work related to cab, air conditioning**

Op. no. 070-810

This operation can be used when work has been done related to the cab, air conditioning and other parts related to function group 8 when no applicable method description was available. When this operation is used, additional information is required:

- Description of work that has been done

**Other work related to hydraulic system**

Op. no. 070-910

This operation can be used when work has been done related to the hydraulic system and other parts related to function group 9 when no applicable method description was available. When this operation is used, additional information is required:

- Description of work that has been done

Document Title: <b>Infrared Thermometer</b>	Function Group: <b>080</b>	Information Type: <b>Service Information</b>	Date: <b>3/24/2026</b>
Profile: <b>EW160E Volvo</b>			

## Infrared Thermometer

Showing Selected Profile

Valid for serial numbers			
Model	Production site	Serial number start	Serial number stop
EW160E Volvo			

### Gun Style Infrared Thermometer Laser Sight Model: SIG1

#### 9998519 Infrared thermometer (user instruction in FGI 080) Application

This tool can be used to measure fast and easy temperature differences. For instance in case of troubleshooting it is sometimes necessary to measure temperature differences on two equal parts with the same surface.



Never point the device towards the eyes permanent eye damage may occur. Use extreme caution when using the laser. Keep out of the reach of children. Be careful around mirror surfaces since mirrors can reflect the laser. Looking into the reflected laser is just as damaging as looking directly at the laser.

#### General information

1. Field of view: The SIG1 takes it's measurement from a circle of a size determined by a simple ratio of 10:1. The diameter of this circle is 1/10 the distance between the target and the tip of the SIG1. For example, if you're standing 20 feet (610 cm) from your target, the size of the circle you're taking the average temperature of will be 2 feet (61 cm) wide.
2. If you want to get the temperature of something small, such as a pipe, you must get close enough for the pipe to take up the whole viewing area circle. Otherwise the pipe and the background temperatures will be averaged into the reading.
3. You need to be aware that if the target surface is reflective enough, it may reflect infrared from other objects. For example, if you take a reading of a shiny metal surface, the infrared energy of your face may reflect enough energy off the surface to affect the reading. For this reason, it's a good idea to put non-reflective tape or paint on reflective surfaces when taking infrared temperature readings.

#### NOTE!

The measured temperature will be lower than actual.

#### Operation

1. Point the laser towards the target to be measured.
2. Pull trigger to light the target with the laser and measure its surface temperature.
3. As long as the trigger is held down, the SIG1 will constantly update the measurement and the blue backlight will illuminate the display.
4. When the trigger is pulled the red laser dot will shine about 1/4" above the centre of the circular area being measured by the thermometer.
5. Once the trigger is released, the last measurement will be shown and held until the trigger is pressed again or until the SIG1 turns off.

Document Title: <b>88830657 User Instruction</b>	Function Group: <b>080</b>	Information Type: <b>Service Information</b>	Date: <b>3/24/2026</b>
Profile: <b>EW160E Volvo</b>			

## 88830657 User Instruction

Showing Selected Profile

Valid for serial numbers			
Model	Production site	Serial number start	Serial number stop
EW160E Volvo			

88830657 Pump is adapted for draining and filling oils in the machine.  
Do not use the pump for coolant or AdBlue®/DEF.

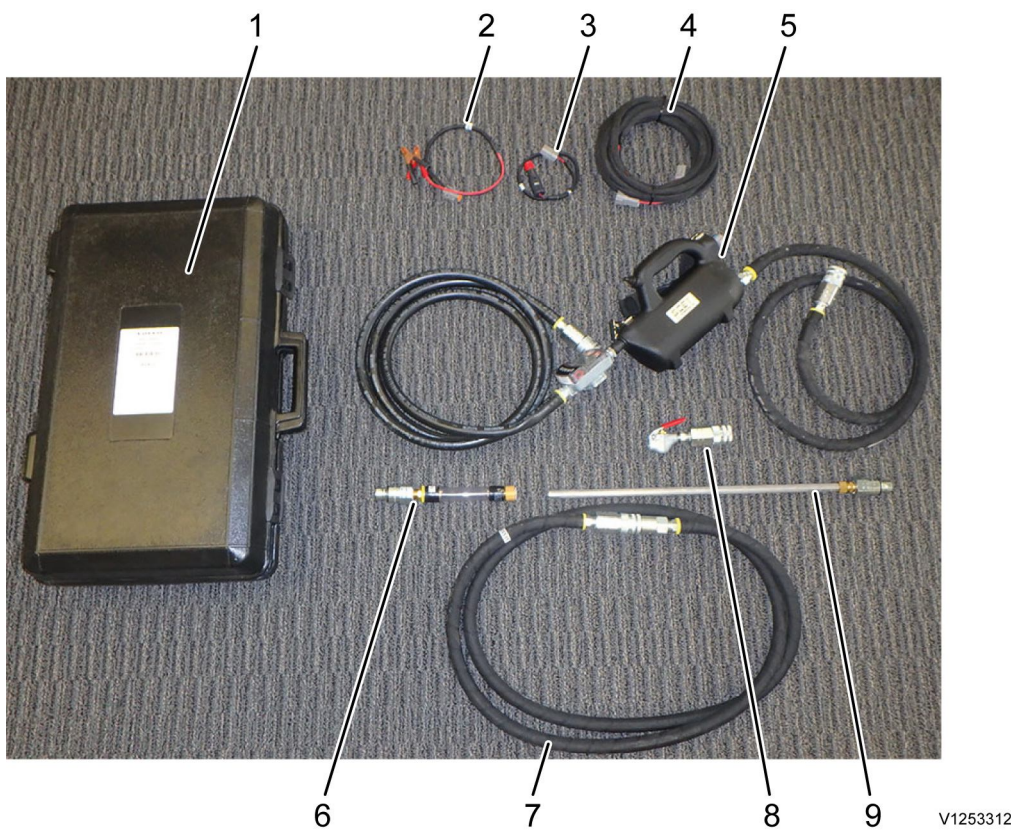

**Figure 1**  
88830657Pump

1. Transport case
2. Power adapter, battery
3. Power adapter, 12 V/24V-outlet
4. Power cable
5. Pump with flow meter and hose 2x2 metres (79 in)
6. Hose adapter for connecting to drain/fill nipple
7. Extension hose 3 metres (118 in)
8. Adapter
9. Suction pipe

## Power supply

Connection of the pump to a power source can take place in two ways:

### Power socket

Connect the power adapter to the power socket of the machine.

### Battery

Connect the power adapter to the battery on the machine.

Red clamp to the positive (plus) connection and black clamp to the negative (minus) connection.

## Draining / Filling

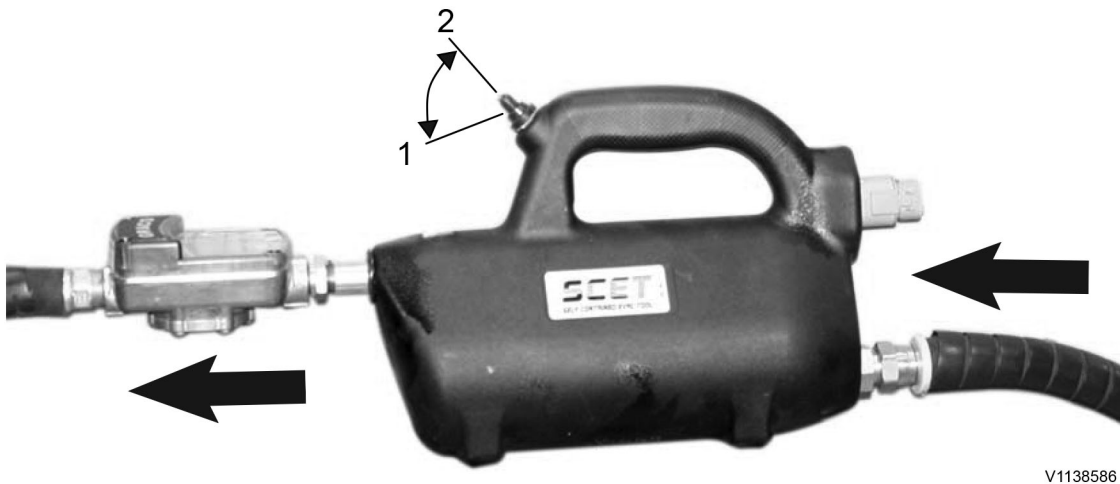

**Figure 2**

Flow direction,

1. Rocker-return pumping position
2. OFF
3. Fixed pumping position

### NOTE!

Always complete draining and filling in one operation to avoid pumping in the wrong oil type in the system.

## Draining

1. Connect the pump to a suitable power source.
2. Connect the pump to the prescribed drain point with suitable adapter. The pump should always be connected so that the oil is pumped in the direction of the arrow, as shown in figure.
3. Hang up the pump in a suitable place for easier operation and reading of the flow meter.
4. Insert the drain hose in a suitable container.
5. Start the pump with the switch. The switch has three positions: OFF, rocker-return pumping position, and fixed pumping position.
6. Turn off the pump when the system is empty.

### NOTE!

If the pump is not used for draining, then before filling it is important to make sure that the wrong oil type is not pumped into the system. This is done by rinsing the pump and its hoses with at least 2 litres (0.53 US gal) of the prescribed oil type.

## Filling

1. Connect the pump to the prescribed fill point with suitable adapter. The pump should always be connected so that the oil is pumped in the direction of the arrow, as shown in figure.
2. Insert the pump's suction hose with the suction pipe in a container with new oil.
3. Start the pump with the switch. The switch has three positions: OFF, rocker-return pumping position, and fixed

- pumping position.
4. Fill the indicated oil volume.

Document Title: <b>88830540 User Instruction</b>	Function Group: <b>080</b>	Information Type: <b>Service Information</b>	Date: <b>3/24/2026</b>
Profile: <b>EW160E Volvo</b>			

## 88830540 User Instruction

Showing Selected Profile

Valid for serial numbers			
Model	Production site	Serial number start	Serial number stop
EW160E Volvo			

### NOTE!

Optional special tool for calibrating the Dig Assist linkage.

Use in combination with laser level "Bosch GPL 3 Professional" only.

### NOTE!

If laser level "Bosch GPL 3 G PROFESSIONAL" is used, replace the bracket (1) by a modified bracket. See [E-3511](#). This is necessary due to a different height of the new laser.

Refer to [36703-3 Dig Assist, calibration, linkage](#).

### Op nbr

### Tools:

[88830540 Fixture](#)

1. Attach the bracket (1) to an arm or boom pin.  
Place the laser level on the bracket.

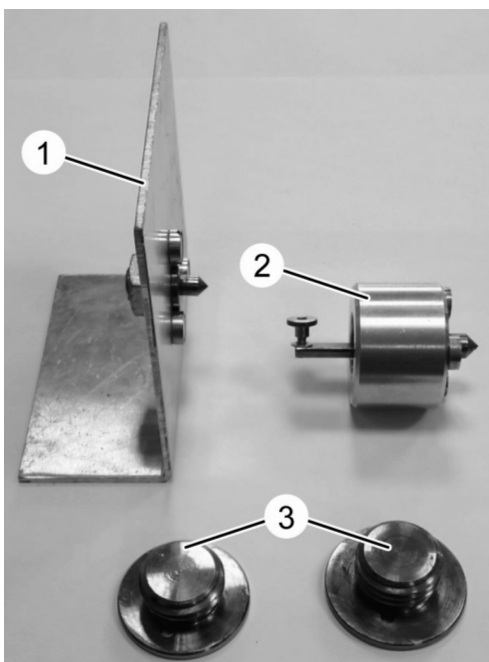

V1180925

**Figure 1**  
88830540

1. Bracket for laser level
  2. Bracket for measuring tape
  3. Centering plugs
2. Attach the bracket (2) to an arm or boom pin.  
Fix the measuring tape to the bracket.
  3. Use the centering plugs if there is no center hole in the pin.

### Examples

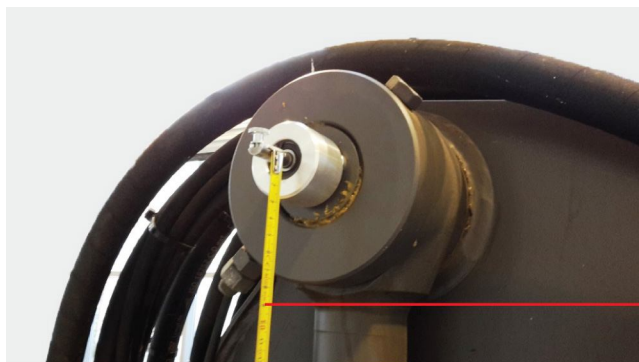

V1177298

Figure 2

Document Title: <b>E-tool, 3500 Support plate for travel gearbox and motor</b>	Function Group: <b>080</b>	Information Type: <b>Service Information</b>	Date: <b>3/24/2026</b>
Profile: <b>EW160E Volvo</b>			

## E-tool, 3500 Support plate for travel gearbox and motor

Showing Selected Profile

Valid for serial numbers			
Model	Production site	Serial number start	Serial number stop
EW160E Volvo			

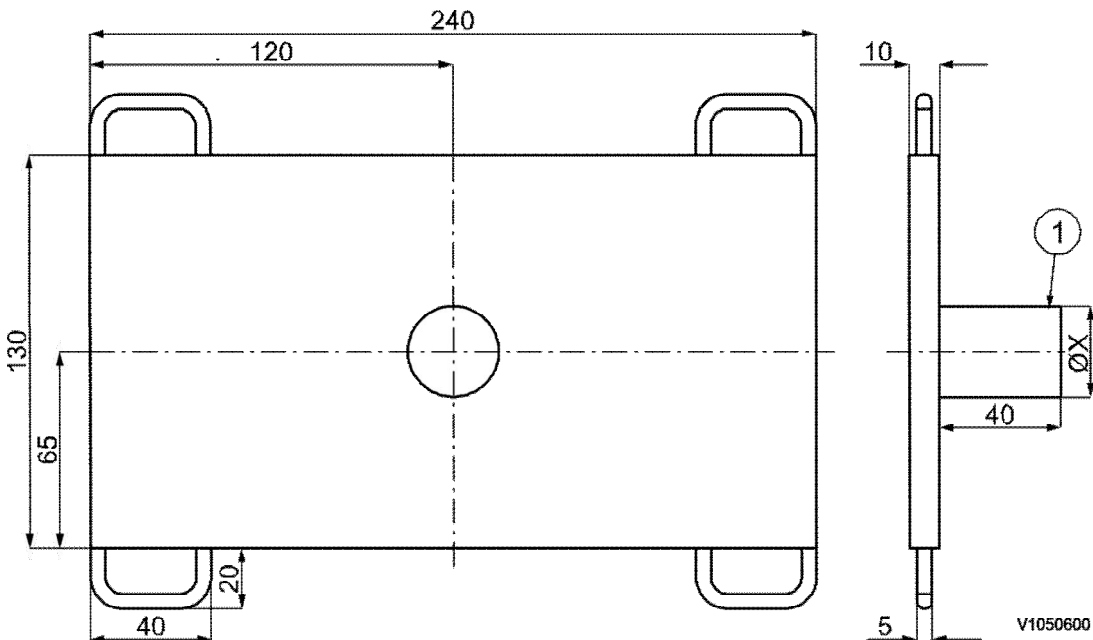

**Figure 1**

Support plate

1. Axle, the dimension  $\text{ØX}$  adapted to the jack