

Document Title: Machine view	Function Group: 000	Information Type: Service Information	Date: 3/24/2026
Profile: EW150E Volvo			

Machine view

Showing Selected Profile

Valid for serial numbers			
Model	Production site	Serial number start	Serial number stop
EW150E Volvo			

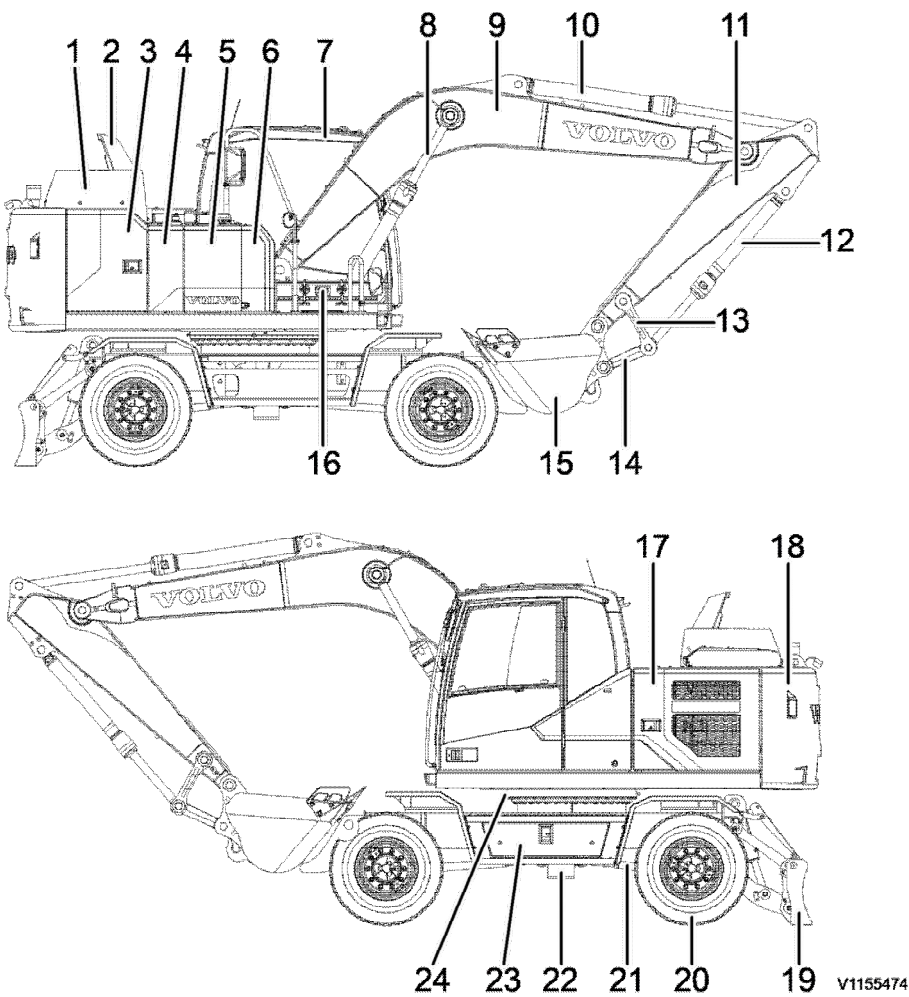

Figure 1
Component locations

1	Engine hood	13	Link
2	Muffler	14	Connecting rod
3	Side cover, right	15	Bucket
4	Hydraulic tank	16	Storage box for air compressor tank
5	Fuel tank	17	Side cover, left
6	AdBlue®/DEF tank	18	Counterweight

7	Operator cab	19	Dozer blade
8	Boom cylinder	20	Tyre
9	Boom	21	Propeller shaft
10	Dipper arm cylinder	22	Travel gearbox and motor
11	Dipper arm	23	Tool box
12	Bucket cylinder	24	Swing ring gear

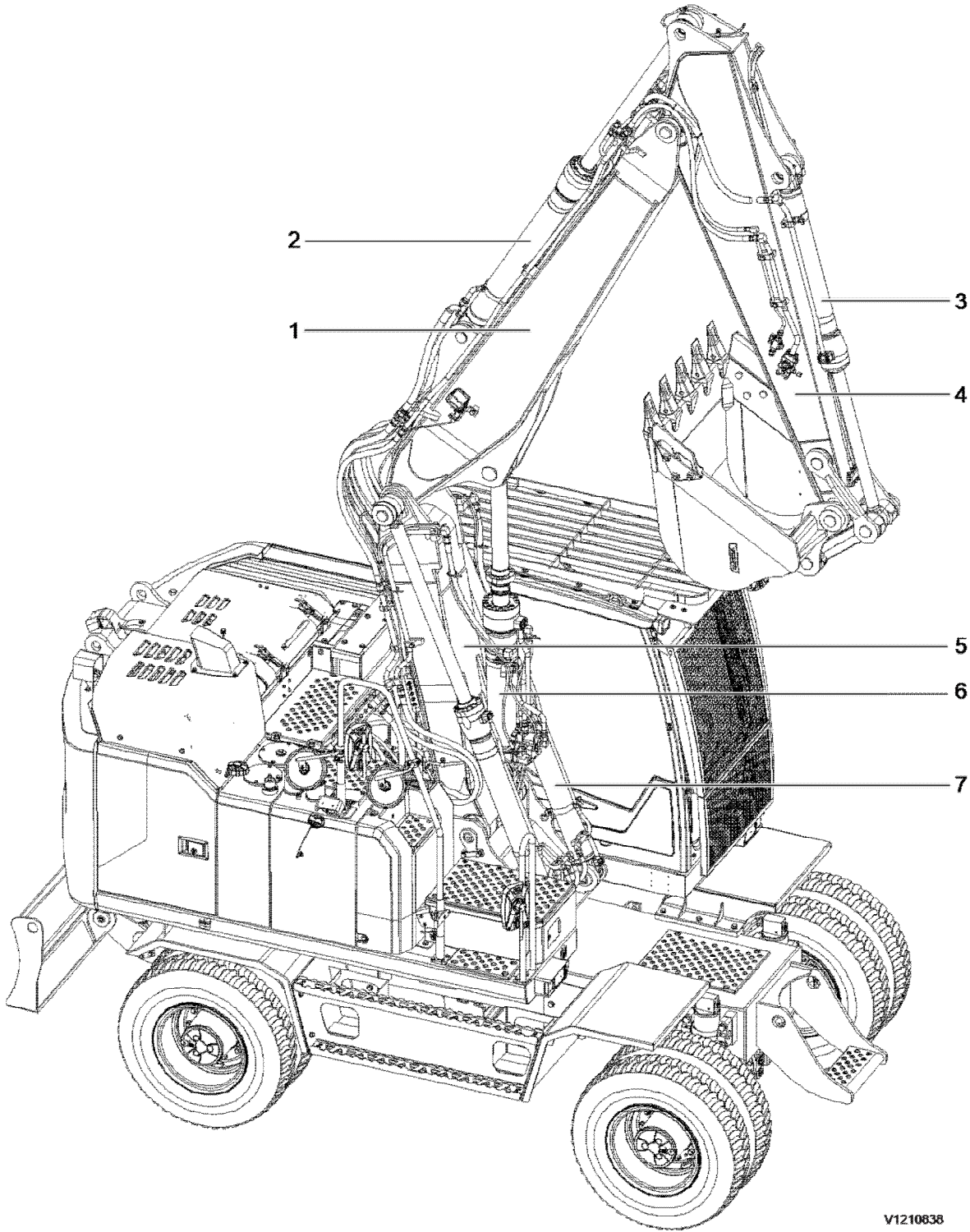

Figure 2

2 Piece boom

2	Dipper arm cylinder	6	2nd boom cylinder
3	Bucket cylinder	7	Boom cylinder
4	Dipper arm		

Document Title: Product plates	Function Group: 000	Information Type: Service Information	Date: 3/24/2026
Profile: EW150E Volvo			

Product plates

Showing Selected Profile

Valid for serial numbers			
Model	Production site	Serial number start	Serial number stop
EW150E Volvo			

Please refer to the figure below to locate the product plate (1), engine plate (2), and attachment plates (3 and 4). Always use the Product Identification Number (PIN) provided on the vehicle and/or engine plates for troubleshooting purposes and/or when ordering spare parts.

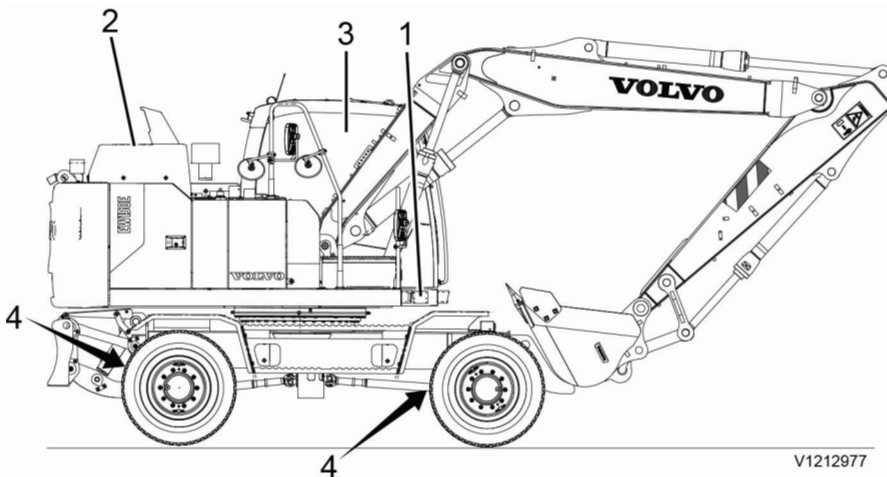

Figure 1

1. Product plate

This plate with **Product Identification Number, PIN**, for the complete machine indicates the model designation, serial number and when applicable, machine weight, engine power, manufacturing year and CE approval. The plate is positioned on the right side of the upper frame.

2. Engine

The engine type designation, part and serial numbers are stamped on the top of valve cover.

3. Cab

The nameplate is attached on the inside of the cab and contains information about product number, machine model, cab serial number, ROPS/TOPS certification number, maximum machine mass and international standard.

4. Axles

The nameplates are attached on the front axle and rear axle, and contain information about the part number, model type and serial number.

Document Title: Volvo standard tightening torques	Function Group: 030	Information Type: Service Information	Date: 3/24/2026
Profile: EW150E Volvo			

Volvo standard tightening torques

Showing Selected Profile

Valid for serial numbers			
Model	Production site	Serial number start	Serial number stop
EW150E Volvo			

The tightening torques in the following tables apply to bolts and nuts with tensile strength. The tables should be used as a general instruction for tightening bolts and nuts without specified values. The charts contains values for course thread bolts and nuts.

Torque values should be increased with $\approx 10\%$, for flange bolts.

All standard torques for bolts are without surface treatment.

The standard torque for bolts lubricated with oil should be reduced with 20% of the given value.

Standard tightening torque charts

Bolt size Metric Coarse Threads	Tensile strength 8.8		Tensile strength 10.9	
	(Nm)	(lbf ft)	(Nm)	(lbf ft)
M5	6	4	8	6
M6	10	7	14	11
M8	25	18	35	26
M10	50	37	70	52
M12	87	64	122	90
M14	139	103	195	144
M16	213	157	299	220
M18	293	216	413	305
M20	416	307	585	432
M24	719	530	1010	745
M27	1060	782	1490	1100
M30	1140	840	2025	1493
M36	2500	1844	3600	2653

Bolt size Inch SAE Coarse Threads	Tensile strength 5		Tensile strength 8	
	(lbf ft)	(Nm)	(lbf ft)	(Nm)
1/4	10	13,6	14	19
5/16	21	28,5	29	39,3
3/8	37	50,2	52	70
7/16	59	80	84	114
1/2	90	122	128	174
9/16	130	176	184	250
5/8	180	244	254	345

3/4	320	434	451	612
7/8	515	700	728	988
1	775	1052	1091	1480
1 1/8	953	1290	1545	2100
1 1/4	1344	1823	2180	2960
1 3/8	1600	2170	2650	3600
1 1/2	2000	2714	3200	4340

Hydraulic connections, general

Before fitting pipe couplings, plugs and hoses:

- Make sure that the sealing surfaces are clean and free from pores or scratches.
- Check elastic seal rings for defects.
- Oil in threads, sealing surfaces and contact surfaces except for ORFS-connections (ORFS = O-Ring Face Seal).

Applying Torque correction factor by tool angle

Tool angle	Correction factor	
	ORFS	Stud-end
Allowable tolerance	$\pm 10\%$	- 0%, +10%
$\pm 0^\circ \sim \pm 30^\circ$	5% over torque	
$\pm 30^\circ \sim \pm 45^\circ$	20% over torque	
$\pm 45^\circ$	NOT allowable	

Tool access angle

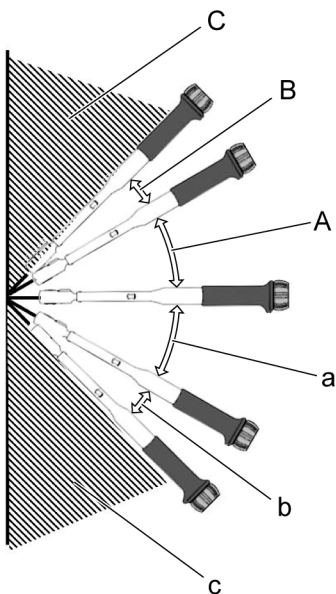

V1223202

Figure 1

Tool access angle

A: $+0^\circ \sim +30^\circ$

B: $+30^\circ \sim +45^\circ$

C: +45°

a: -0° ~ -30°

b: -30° ~ -45°

c: -45°

ORFS female swivel fitting

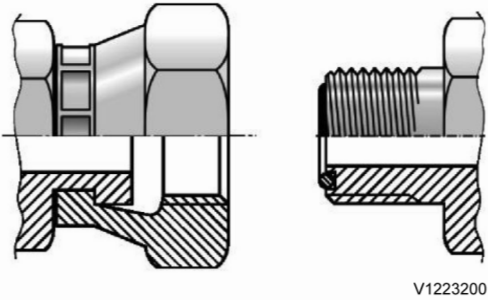

Figure 2

Thread s type	Assembl y position	Threads	Standard torque		±0° ~ ±30°		±30° ~ ±45°	
			(Nm)	(lbf ft)	(Nm)	(lbf ft)	(Nm)	(lbf ft)
UN- UNF	ORFS	UNF 9/16-18	29 ±3	21.4 ±2.2	30.5 ±3.1	22.1 ±2.2	36.5 ±3.7	26.9 ±2.7
		UN 11/16-16	44 ±4	32.5 ±3.0	46.2 ±4.6	34.1 ±3.4	55.4 ±5.5	40.9 ±4.1
		UN 13/16-16	63 ±6	46.5 ±4.4	66.2 ±6.6	48.8 ±4.9	79.4 ±7.9	58.6 ±5.9
		UNS 1-14	106 ±8	78.2 ±5.9	111.3 ±11.1	82.1 ±8.2	133.6 ±13.4	98.5 ±9.9
		UN 1 3/16-12	140 ±12	103.3 ±8.9	147.0 ±14.7	108.4 ±10.8	176.4 ±17.6	130.1 ±13.0
		UN 1 7/16-12	175 ±15	129.1 ±11.1	183.8 ±18.4	135.6 ±13.6	220.5 ±22.1	162.6 ±16.3
		UN 1 11/16-12	270 ±20	199.1 ±14.8	283.5 ±28.4	209.1 ±20.9	340.2 ±34.0	250.9 ±25.1
	Stud-end	UNF 7/16-20	21 +2.1	15.4 +1.5	22.1 +2.2	16.3 +1.6	26.5 +2.7	19.5 +2.0
		UNF 1/2-20	37 +3.7	27.3 +2.7	38.9 +3.9	28.7 +2.9	46.6 +4.7	34.4 +3.4
		UNF 9/16-18	47 +4.7	34.7 +3.5	49.4 +4.9	36.4 +3.6	59.2 +5.9	43.7 +4.4
		UNF 3/4-16	81 +8.1	59.7 +6.0	85.1 +8.5	62.8 +6.3	102.1 +10.2	75.3 +7.5
		UNF 7/8-14	141 +14.1	104.0 +10.4	148.1 +14.8	109.2 +10.9	177.7 +17.8	131.1 +13.1
		UN 1 1/16-12	189 +18.9	139.4 +13.9	198.5 +19.9	146.4 +14.6	238.1 +23.8	175.6 +17.6
		UN 1 5/16-12	284 +28.4	209.5 +21.0	298.2 +29.8	219.9 +22.0	357.8 +35.8	263.9 +26.4
UN 1 5/8-12	347 +34.7	255.9 +25.6	364.4 +36.4	268.8 +26.9	437.2 43.7	322.5 +32.3		

UN 1 7/8-12	425 +42.5	313.5 +31.4	446.3 +44.6	329.2 +32.9	535.5 +53.6	395.0 +39.5
----------------	-----------	-------------	-------------	-------------	-------------	-------------

G thread 30° cone female swivel fitting

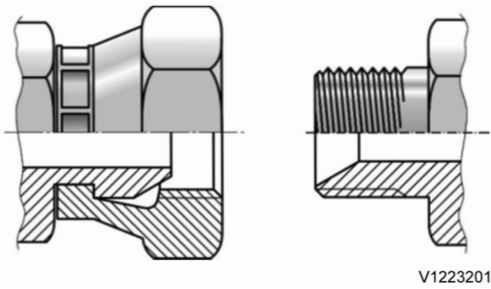

Figure 3

Thread s type	Assembl y position	Threads	Standard torque		±0° ~ ±30°		±30° ~ ±45°	
			(Nm)	(lbf ft)	(Nm)	(lbf ft)	(Nm)	(lbf ft)
PF	ORFS	G 1/4-19	25 ±2.5	18.4 ±1.8	26.3 ± 2.6	19.4 ±1.9	31.5 ±3.2	23.2 ±2.3
		G 3/8-19	49 ±4.9	36.1 ±3.6	51.5 ± 5.2	38.0 ±3.8	61.7 ±6.2	45.5 ±4.6
		G 1/2-14	59 ±5.9	43.5 ±4.4	62.0 ± 6.2	45.7 ±4.6	74.3 ±7.4	54.8 ±5.5
		G 3/4-11	119 ±11.9	87.8 ±8.8	125.0 ±12.5	92.2 ±9.2	149.9 ±15.0	110.6 ±11.1
		G 1-11	140 ±14	103.3 ±10.3	147.0 ±14.7	108.4 ±10.8	176.4 ±17.6	130.1 ±13.0
		G 1 1/4-11	173 ±17.3	127.6 ±12.8	181.7 ±18.2	134.0 ±13.4	218.0 ±21.8	160.8 ±16.1
		G 1 1/2-11	205 ±20.5	151.2 ±15.1	215.3 ±21.5	158.8 ±15.9	258.3 ±25.8	190.5 ±19.1
	Stud-end	G 1/8-19	22 +2.2	16.2 +1.6	23.1 +2.3	17.0 +1.7	27.7 +2.8	20.4 +2.0
		G 1/4-19	52 +5.2	38.4 +3.8	54.6 +5.5	40.3 +4.0	65.5 +6.6	48.3 +4.8
		G 3/8-19	85 +8.5	62.7 +6.3	89.3 +8.9	65.9 +6.6	107.1 +10.7	79.0 +7.9
		G 1/2-14	105 +10.5	77.4 +7.7	110.3 +11.0	81.4 +8.1	132.3 +13.2	97.6 +9.8
		G 3/4-11	210 +21	154.9 +15.5	220.5 +22.1	162.6 +16.3	264.6 +26.5	195.2 +19.5
		G 1-11	400 +40	295.0 +29.5	420.0 +42.0	309.8 +31.0	504.0 +50.4	371.7 +37.1
		G 1 1/4-11	525 +52.5	387.2 +38.7	551.3 +55.1	406.6 +40.7	661.5 +66.2	487.9 +48.8
G 1 1/2-11	630 +63.1	464.7 +46.5	661.5 +66.2	487.9 +48.8	793.8 +79.4	585.5 +58.6		

Document Title: Measurement conversion tables	Function Group: 030	Information Type: Service Information	Date: 3/24/2026
Profile: EW150E Volvo			

Measurement conversion tables

Showing Selected Profile

Valid for serial numbers			
Model	Production site	Serial number start	Serial number stop
EW150E Volvo			

Length

Unit	cm	m	km	in	ft	yd	mile
cm	1	0.01	0.00001	0.3937	0.03281	0.01094	0.000006
m	100	1	0.001	39.37	3.2808	1.0936	0.00062
km	100000	1000	1	39370.7	3280.8	1093.6	0.62137
in	2.54	0.0254	0.000025	1	0.08333	0.02777	0.000015
ft	30.48	0.3048	0.000304	12	1	0.3333	0.000189
yd	91.44	0.9144	0.000914	36	3	1	0.000568
mile	160930	1609.3	1.6093	63360	5280	1760	1

1 mm = 0.1 cm, 1 mm = 0.001 m

Area

Unit	cm ²	m ²	km ²	a	ft ²	yd ²	in ²
cm ²	1	0.0001	-	0.000001	0.001076	0.000012	0.155000
m ²	10000	1	0.000001	0.01	10.764	1.1958	1550.000
km ²	-	1000000	1	10000	1076400	1195800	-
a	0.01	100	0.0001	1	1076.4	119.58	-
ft ²	-	0.092903	-	0.000929	1	0.1111	144.000
yd ²	-	0.83613	-	0.008361	9	1	1296.00
in ²	6.4516	0.000645	-	-	0.006943	0.000771	1

1 ha = 100 a, 1 mile² = 259 ha = 2.59 km²

Volume

Unit	cm ³ = cc	m ³	Liter	in ³	ft ³	yd ³
cm ³ = m liter	1	0.000001	0.001	0.061024	0.000035	0.000001
m ³	1000000	1	1000	61024	35.315	1.30796
Liter	1000	0.001	1	61.024	0.035315	0.001308
in ³	16.387	0.000016	0.01638	1	0.000578	0.000021
ft ³	28316.8	0.028317	28.317	1728	1	0.03704
yd ³	764529.8	0.76453	764.53	46656	27	1

1 gal(US) = 3785.41 cm³ = 231 in³ = 0.83267 gal(UK)

Weight

Unit	g	kg	t	oz	lb
g	1	0.001	0.000001	0.03527	0.0022
kg	1000	1	0.001	35.273	2.20459
t	1000000	1000	1	35273	2204.59
oz	28.3495	0.02835	0.000028	1	0.0625
lb	453.592	0.45359	0.000454	16	1

1 tonne(metric) = 1.1023 ton(US) = 0.9842 ton(UK)

Pressure

Unit	kgf/cm ²	bar	Pa=N/m ²	kPa	lbf/in ²	lbf/ft ²
kgf/cm ²	1	0.98067	98066.5	98.0665	14.2233	2048.16
bar	1.01972	1	100000	100	14.5037	2088.6
Pa=N/m ²	0.00001	0.001	1	0.001	0.00015	0.02086
kPa	0.01020	0.01	1000	1	0.14504	20.886
lbf/in ²	0.07032	0.0689	6894.76	6.89476	1	144
lbf/ft ²	0.00047	0.00047	47.88028	0.04788	0.00694	1

1 kgf/cm² = 735.56 Torr(mmHg) = 0.96784 atm

Approximate conversions

SI	Conversion	Non-SI	Conversion	SI
Unit	Factor	Unit	Factor	Unit
Torque				
newton meter (N·m)	x 10.2	= kgf·cm	x 0.8664	= (lbf·in)
newton meter (N·m)	x 0.74	= lb·ft	x 1.36	= N·m
newton meter (N·m)	x 0.102	= kgf·m	x 7.22	= (lbf·ft)
Pressure (Pa = N/m²)				
kilopascal (kPa)	x 4.0	= in. H ₂ O	x 0.249	= kPa
kilopascal (kPa)	x 0.30	= in. Hg	x 3.38	= kPa
kilopascal (kPa)	x 0.145	= psi	x 6.89	= kPa
(bar)	x 14.5	= psi	x 0.069	= (bar)
(kgf/cm ²)	x 14.22	= psi	x 0.070	= (kgf/cm ²)
(newton/mm ²)	x 145.04	= psi	x 0.069	= (bar)
megapascal (MPa)	x 145	= psi	x 0.00689	= MPa
Power (W = J/s)				
kilowatt (kW)	x 1.36	= PS (cv)	x 0.736	= kW
kilowatt (kW)	x 1.34	= HP	x 0.746	= kW
kilowatt (kW)	x 0.948	= Btu/s	x 1.055	= kW
watt (W)	x 0.74	= ft·lb/s	x 1.36	= W

Note: () non-si unit

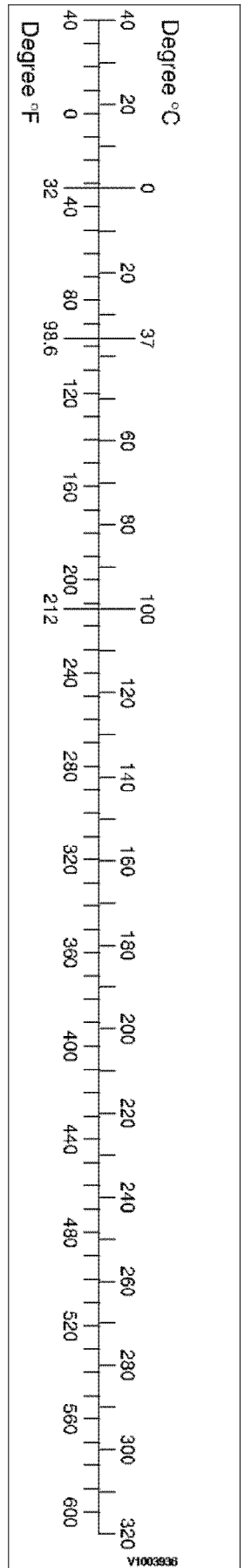

Approximate conversions

SI Unit	Conversion Factor	Non-SI Unit	Conversion Factor	SI Unit

Energy (J = N·m)				
kilojoule (kJ)	x 0.948	= Btu	x 1.055	= kJ
joule (J)	x 0.239	= calorie	x 4.19	= J
Velocity and Acceleration				
meter per sec ² (m/s ²)	x 3.28	= ft/s ²	x 0.305	= m/s ²
meter per sec (m/s)	x 3.28	= ft/s	x 0.305	= m/s
kilometer per hour (km/h)	x 0.62	= mph	x 1.61	= km/h
Horse power/torque				
BHP x 5252 rpm = TQ (lb·ft)			TQ x rpm 5252 = B.H.P.	
Temperature				
°C = (°F - 32) / 1.8		°F = (°C x 1.8) + 32		
Flow Rate				
liter/min (dm ³ /min)	x 0.264	= US gal/min x 3.785		= liter/min

Note: () non-si unit

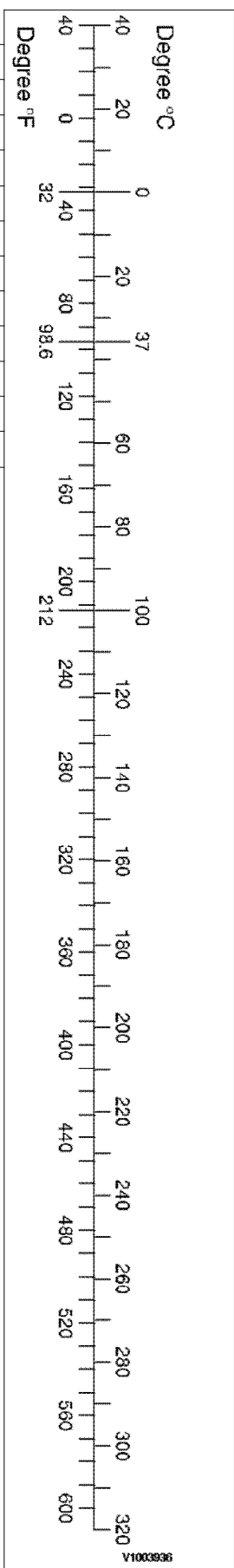

Document Title: Operation numbers for additional work	Function Group: 070	Information Type: Service Information	Date: 3/24/2026
Profile: Excavators (EXC)			

Operation numbers for additional work

Showing Selected Profile

These operations can be used to identify work that is not included in the time guide or described in the methods in the Service Manual. When these operations are used, a description of the work that has been performed must be provided.

Other work related to engine

Op. no. 070-210

This operation can be used when work has been done related to the engine and function group 2 when no applicable method description was available. When this operation is used, additional information is required:

- Description of work that has been done

Other work related to electrical system

Op. no. 070-310

This operation can be used when work has been done related to the electrical system and function group 3 when no applicable method description was available. When this operation is used, additional information is required:

- Description of work that has been done

Other work related to transmission, gearbox, travel motor, swing motor

Op. no. 070-410

This operation can be used when work has been done related to the transmission, gearbox, travel motor or swing motor and function group 4 when no applicable method description was available. When this operation is used, additional information is required:

- Description of work that has been done

Other work related to drive axle

Op. no. 070-470

This operation can be used when work has been done related to the drive axle and function group 46 when no applicable method description was available. When this operation is used, additional information is required:

- Description of required work that have been done

Other work related to brake system

Op. no. 070-510

This operation can be used when work has been done related to the brake system and function group 5 when no applicable

method description was available. When this operation is used, additional information is required:

- Description of work that has been done

Other work related to steering system

Op. no. 070-610

This operation can be used when work has been done related to the steering system and function group 6 when no applicable method description was available. When this operation is used, additional information is required:

- Description of work that has been done

Other work related to frame link, axle suspension

Op. no. 070-710

This operation can be used when work has been done related to the frame link, axle suspension and other parts related to function group 7 when no applicable method description was available. When this operation is used, additional information is required:

- Description of work that has been done

Other work related to cab, air conditioning

Op. no. 070-810

This operation can be used when work has been done related to the cab, air conditioning and other parts related to function group 8 when no applicable method description was available. When this operation is used, additional information is required:

- Description of work that has been done

Other work related to hydraulic system

Op. no. 070-910

This operation can be used when work has been done related to the hydraulic system and other parts related to function group 9 when no applicable method description was available. When this operation is used, additional information is required:

- Description of work that has been done

Document Title: NET 8940-00190 Travel motor guide pin	Function Group: 080	Information Type: Service Information	Date: 3/24/2026
Profile: EW150E Volvo			

NET 8940-00190 Travel motor guide pin

Showing Selected Profile

Valid for serial numbers			
Model	Production site	Serial number start	Serial number stop
EW150E Volvo			

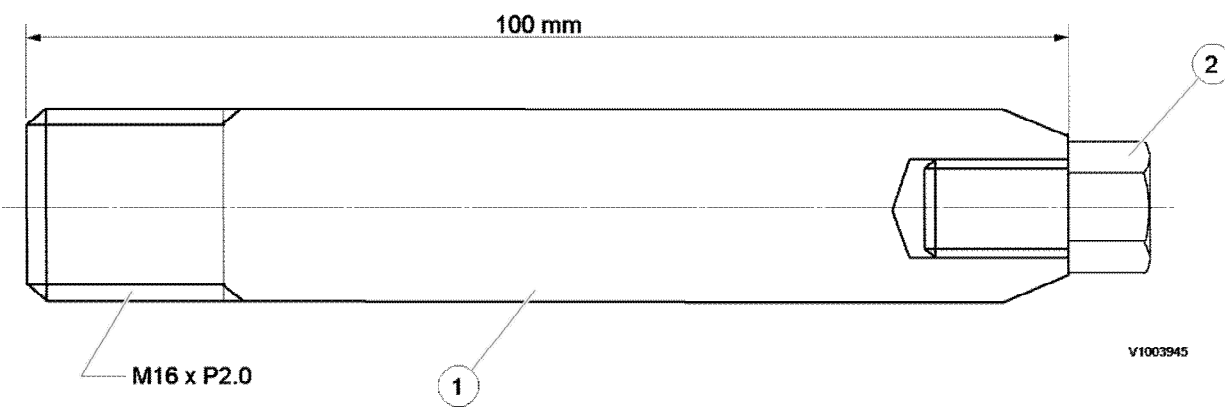

Figure 1
Travel motor guide pin

Item	Quantity	Name	Remark
1	2	Guide bar	SAE 4130 (25 ~ 35 HRC)
2	2	Screw	M8 × 16

Document Title: NET 8940-00200 Replace tool for the remote control valve joint	Function Group: 080	Information Type: Service Information	Date: 3/24/2026
Profile: EW150E Volvo			

NET 8940-00200 Replace tool for the remote control valve joint

Showing Selected Profile

Valid for serial numbers			
Model	Production site	Serial number start	Serial number stop
EW150E Volvo			

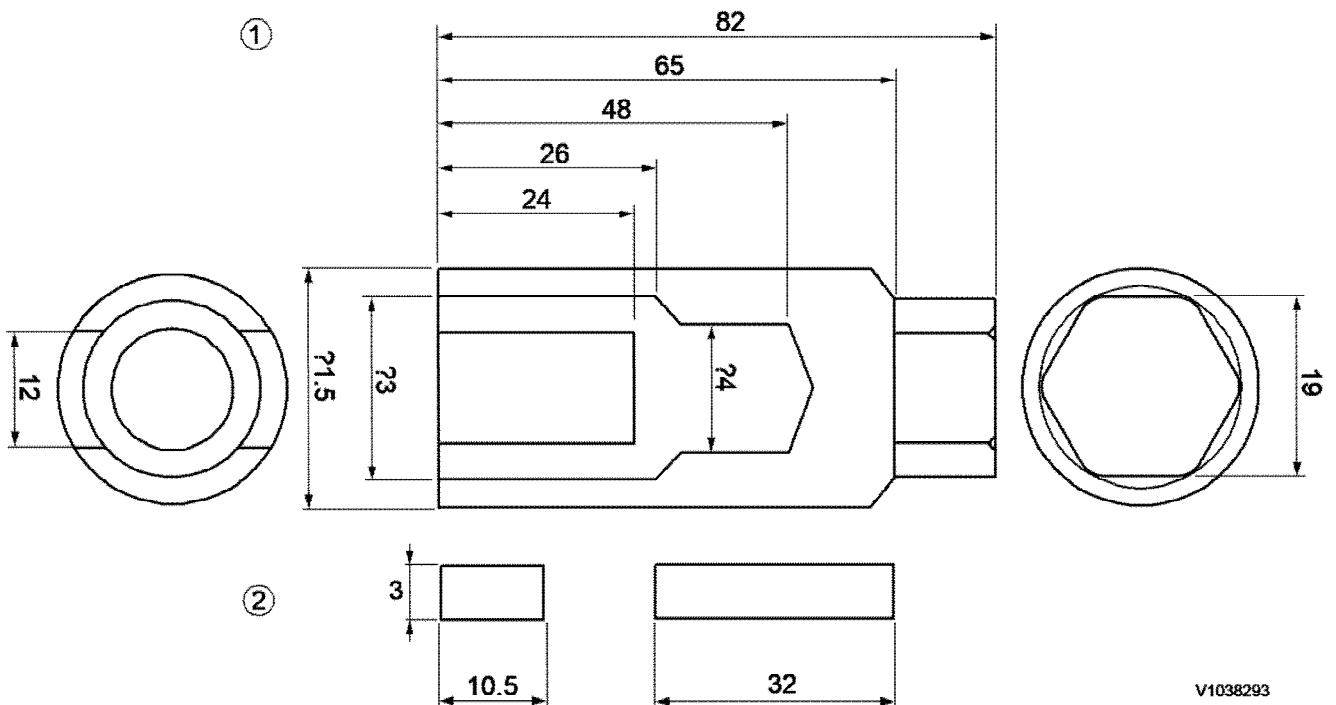

V1038293

Figure 1
Replace tool for the remote control valve joint

Item	Quantity	Name	Remark
1	1	Socket	SAE 4130 (QT)
2	1	Stop plate	SAE 4130 (QT)

Document Title: E-tools, NET 8940-00310 Replace tool for the swing ring gear	Function Group: 080	Information Type: Service Information	Date: 3/24/2026
Profile: EW150E Volvo			

E-tools, NET 8940-00310 Replace tool for the swing ring gear

Showing Selected Profile

Valid for serial numbers			
Model	Production site	Serial number start	Serial number stop
EW150E Volvo			

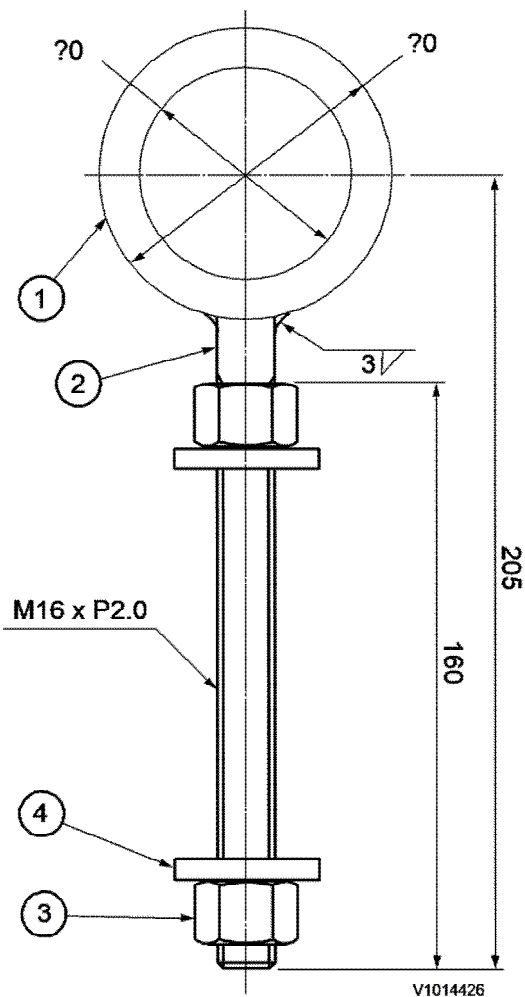

Figure 1

Replace tool for the swing ring gear

Item	Quantity	Name	Remark
1	2	Ring	SAE 1045 (QT)
2	2	Round bar $\phi 16$	SAE 1045 (QT)
3	4	Nut	M16

4

4

Washer $\varphi 16 \times \varphi 35 \times 10$ t

Document Title: NET 8940-00430 Replace tool for the travel motor guide pin	Function Group: 080	Information Type: Service Information	Date: 3/24/2026
Profile: EW150E Volvo			

NET 8940-00430 Replace tool for the travel motor guide pin

Showing Selected Profile

Valid for serial numbers			
Model	Production site	Serial number start	Serial number stop
EW150E Volvo			

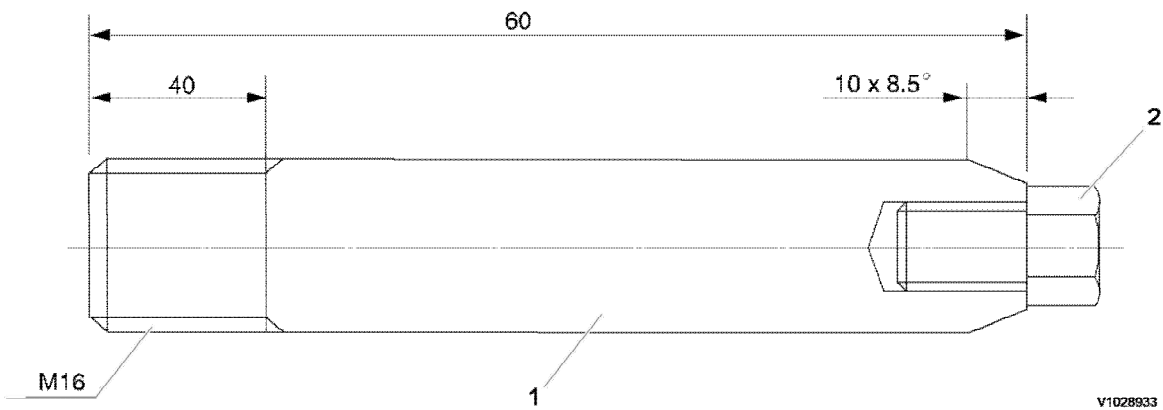

Figure 1

Replace tool for the travel motor guide pin

Item	Quantity	Name	Remark
1	2	Guide bar	SAE 4130 (25 ~ 35 HRC)
2	2	Screw	M8 x 1.0 x 16L

Document Title: Infrared Thermometer	Function Group: 080	Information Type: Service Information	Date: 3/24/2026
Profile: EW150E Volvo			

Infrared Thermometer

Showing Selected Profile

Valid for serial numbers			
Model	Production site	Serial number start	Serial number stop
EW150E Volvo			

Gun Style Infrared Thermometer Laser Sight Model: SIG1

9998519 Infrared thermometer (user instruction in FGI 080) Application

This tool can be used to measure fast and easy temperature differences. For instance in case of troubleshooting it is sometimes necessary to measure temperature differences on two equal parts with the same surface.



WARNING

Never point the device towards the eyes permanent eye damage may occur. Use extreme caution when using the laser. Keep out of the reach of children. Be careful around mirror surfaces since mirrors can reflect the laser. Looking into the reflected laser is just as damaging as looking directly at the laser.

General information

1. Field of view: The SIG1 takes it's measurement from a circle of a size determined by a simple ratio of 10:1. The diameter of this circle is 1/10 the distance between the target and the tip of the SIG1. For example, if you're standing 20 feet (610 cm) from your target, the size of the circle you're taking the average temperature of will be 2 feet (61 cm) wide.
2. If you want to get the temperature of something small, such as a pipe, you must get close enough for the pipe to take up the whole viewing area circle. Otherwise the pipe and the background temperatures will be averaged into the reading.
3. You need to be aware that if the target surface is reflective enough, it may reflect infrared from other objects. For example, if you take a reading of a shiny metal surface, the infrared energy of your face may reflect enough energy off the surface to affect the reading. For this reason, it's a good idea to put non-reflective tape or paint on reflective surfaces when taking infrared temperature readings.

NOTE!

The measured temperature will be lower than actual.

Operation

1. Point the laser towards the target to be measured.
2. Pull trigger to light the target with the laser and measure its surface temperature.
3. As long as the trigger is held down, the SIG1 will constantly update the measurement and the blue backlight will illuminate the display.
4. When the trigger is pulled the red laser dot will shine about 1/4" above the centre of the circular area being measured by the thermometer.
5. Once the trigger is released, the last measurement will be shown and held until the trigger is pressed again or until the SIG1 turns off.

Document Title: 88830540 User Instruction	Function Group: 080	Information Type: Service Information	Date: 3/24/2026
Profile: EW150E Volvo			

88830540 User Instruction

Showing Selected Profile

Valid for serial numbers			
Model	Production site	Serial number start	Serial number stop
EW150E Volvo			

NOTE!

Optional special tool for calibrating the Dig Assist linkage.

Use in combination with laser level "Bosch GPL 3 Professional" only.

NOTE!

If laser level "Bosch GPL 3 G PROFESSIONAL" is used, replace the bracket (1) by a modified bracket. See [E-3511](#). This is necessary due to a different height of the new laser.

Refer to [36703-3 Dig Assist, calibration, linkage](#).

Op nbr

Tools:

[88830540 Fixture](#)

1. Attach the bracket (1) to an arm or boom pin.
Place the laser level on the bracket.

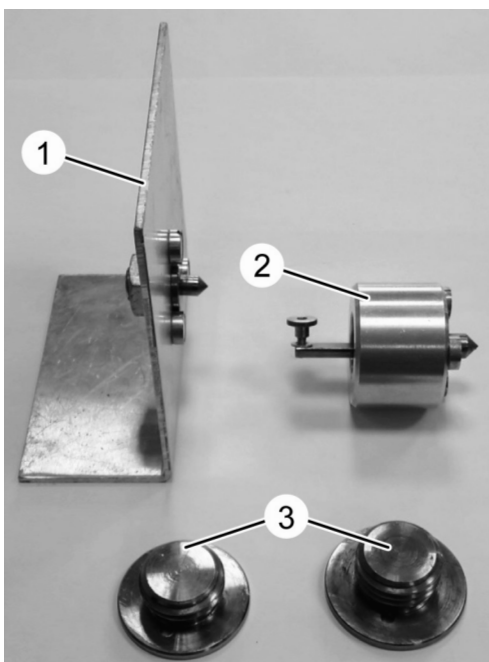

V1180925

Figure 1
88830540

1. Bracket for laser level
 2. Bracket for measuring tape
 3. Centering plugs
2. Attach the bracket (2) to an arm or boom pin.
Fix the measuring tape to the bracket.
3. Use the centering plugs if there is no center hole in the pin.

Examples

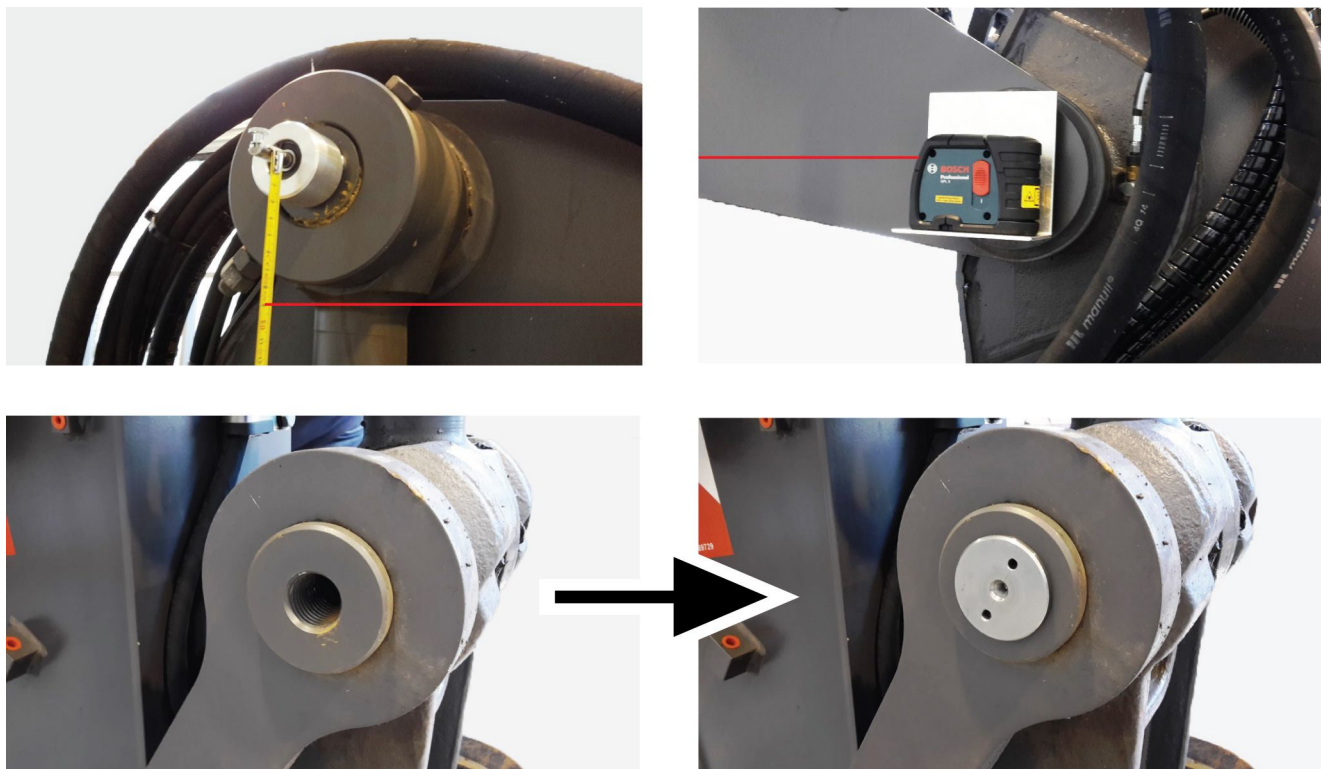

V1177298

Figure 2

Document Title: E-3511	Function Group: 080	Information Type: Service Information	Date: 3/24/2026
Profile: EW150E Volvo			

E-3511

Showing Selected Profile

Valid for serial numbers			
Model	Production site	Serial number start	Serial number stop
EW150E Volvo			

Bracket for new laser Bosch GPL with 77mm laserpoint – height

This bracket is an additional E-Tool for the Special Tool Part No.88830540 in case a laser with 77mm laserpoint height is used. see: [36703-3 Dig Assist. calibration, linkage](#)

Dimensions on the drawing are given in mm.

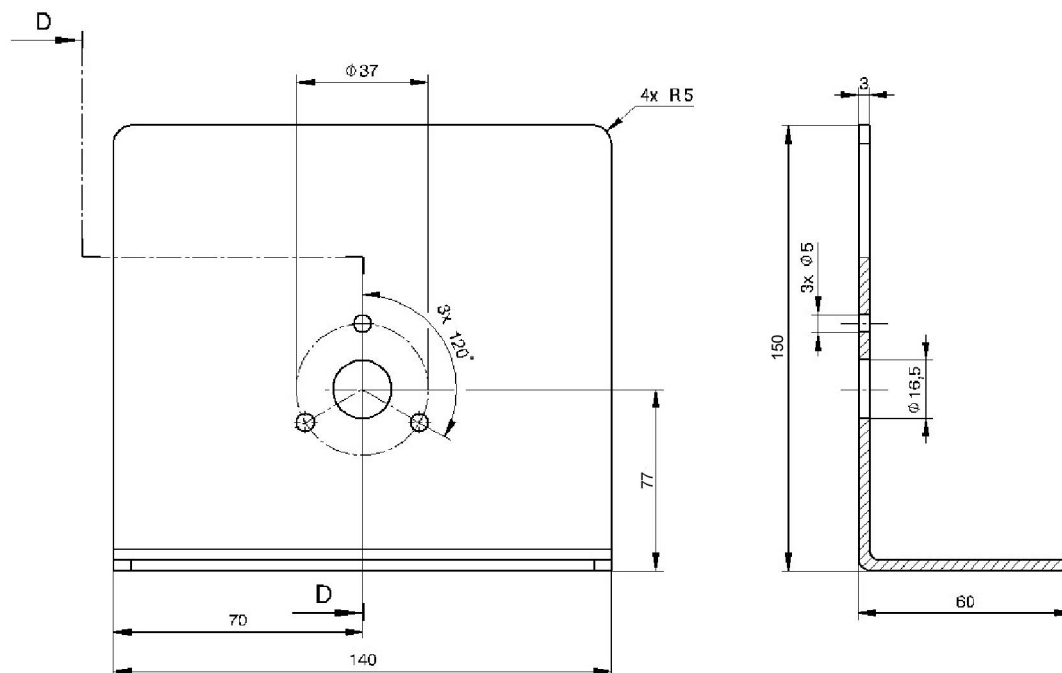

V1231147

Figure 1
Drawing



V1231148

Figure 2

Bracket

Centre adjustment and magnets are to be used from the existing bracket.

Document Title: E-3512	Function Group: 080	Information Type: Service Information	Date: 3/24/2026
Profile: EW150E Volvo			

E-3512

Showing Selected Profile

Valid for serial numbers			
Model	Production site	Serial number start	Serial number stop
EW150E Volvo			

This tool is necessary for the Dig Assist GNSS antennas position, adjusting. see [Dig Assist GNSS antennas position, adjusting](#)

Measuring tool to aligning with the centre point of the boom pin.

NOTE!

In order to use the e-tool as intended, it must consist of the following components:

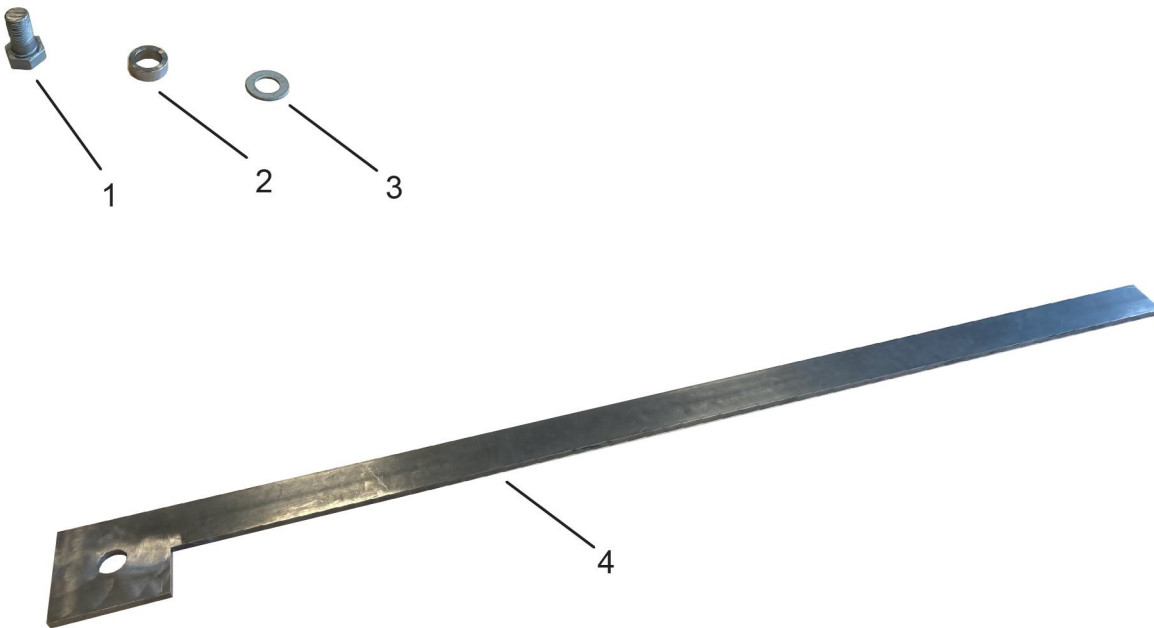

V1231959

Figure 1

E-3512

Position in fig.1	Description	Part no	Qty
1	Hexagon Screw M30x90 (cut off 30mm)	60110043 (Figure 4)	1

2	Spacer	(Figure 3)	1
3	Washer 31x58x4	60113306	1
4	Measuring tool	(Figure 2)	1

Measuring tool (4)

Dimensions on the drawing are given in mm.

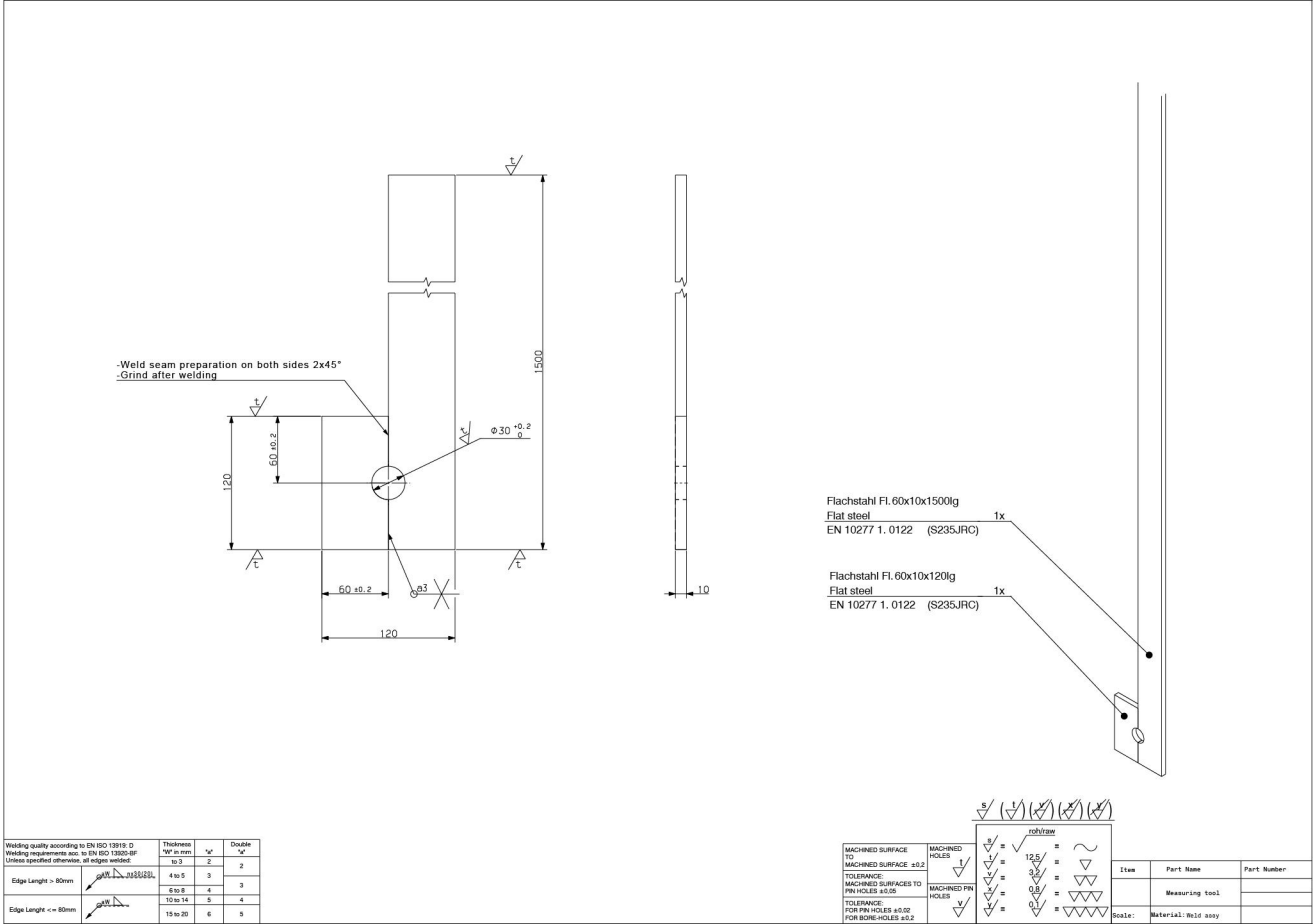
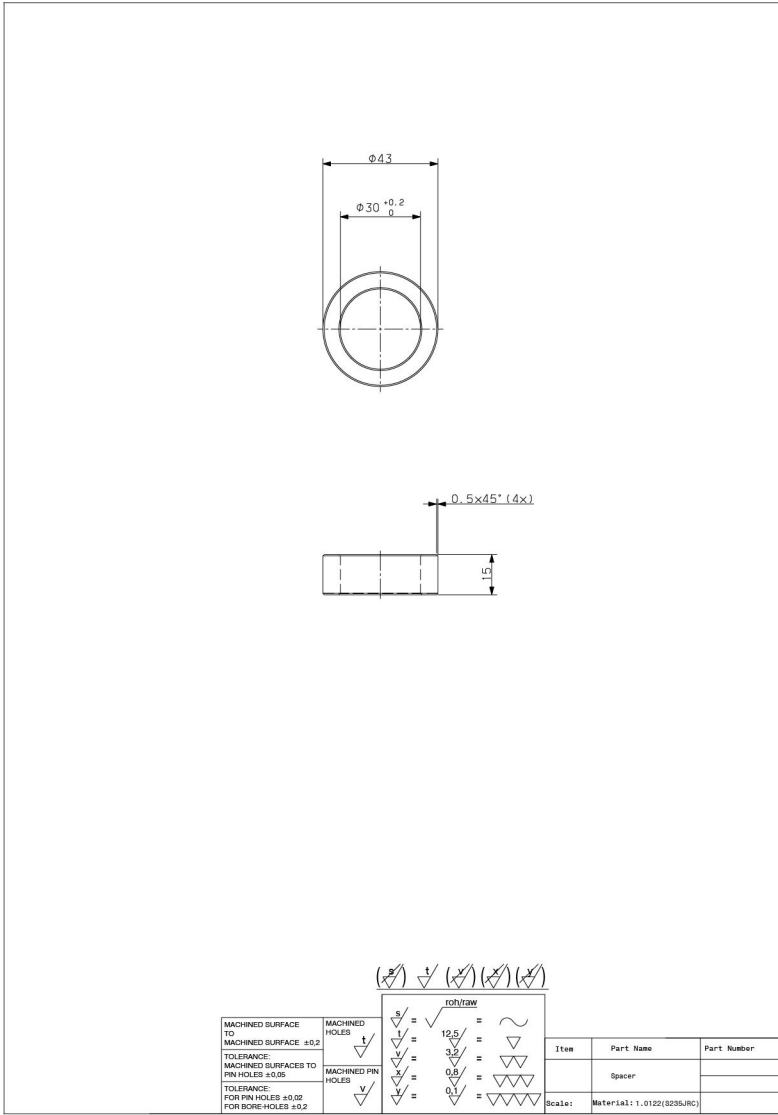

Figure 2
Measuring tool

Spacer (2)

Dimensions on the drawing are given in mm.



V1231676

Figure 3
Spacer

Screw M30x90 (cut off 30mm) (1)

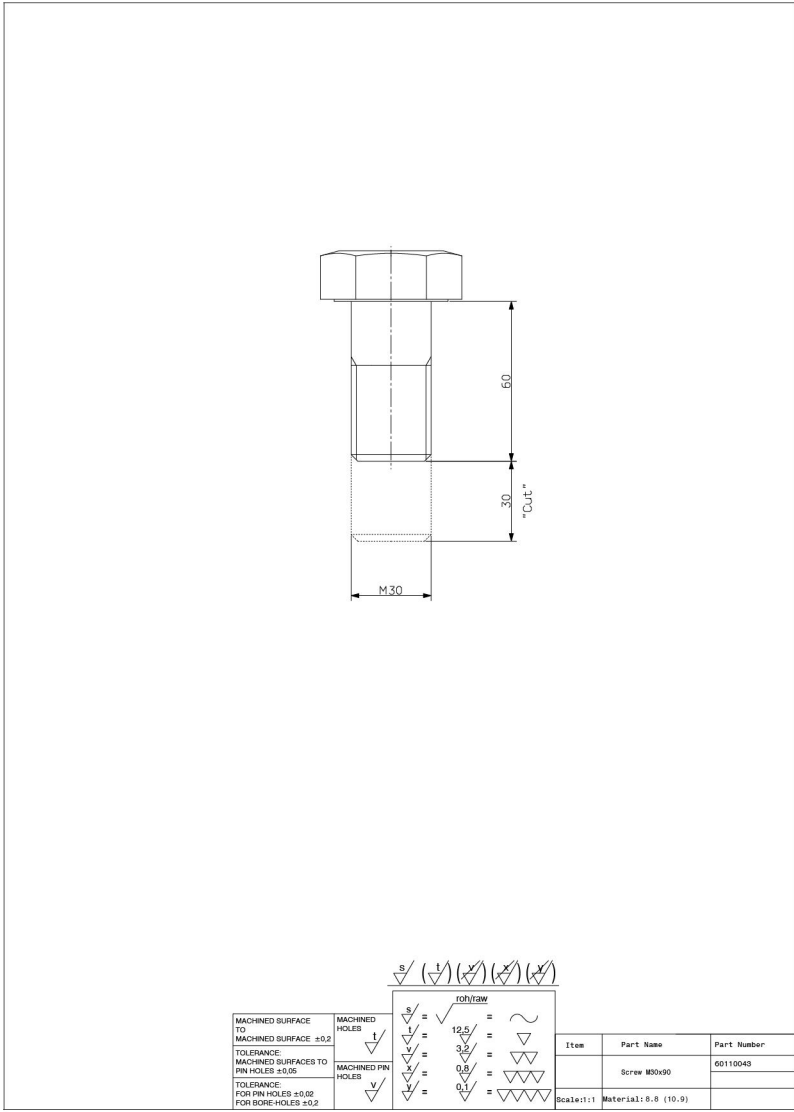

V1231677

Figure 4
Screw M30x90

NOTE!

To use the tool on an EWR130E, a different screw and spacer must be made (see figure 5 and 6). Additional Parts are needed.

Position in fig.1	Description	Part no	Qty
2	Spacer	(Figure 5)	1
1	Hexagon Screw M20x70 (cut off 15mm)	997474 (Figure 6)	1
3	Washer 21x52x3	60110288	1

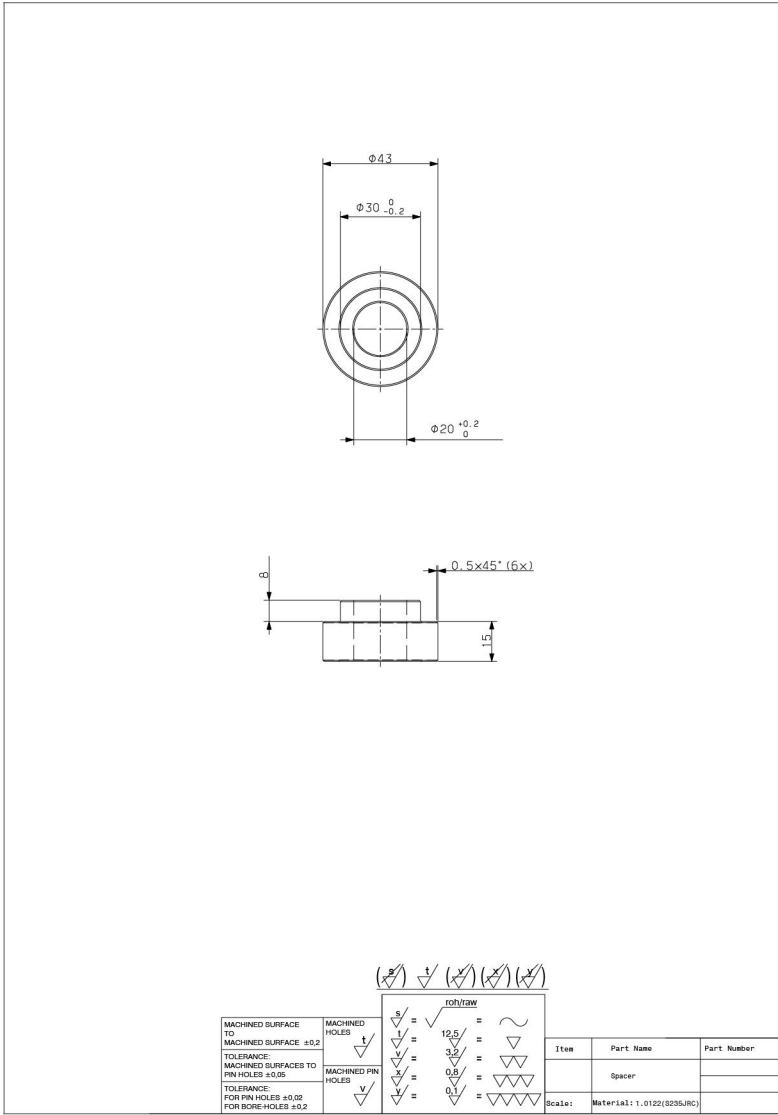

V1231683

Figure 5
Spacer EWR130E

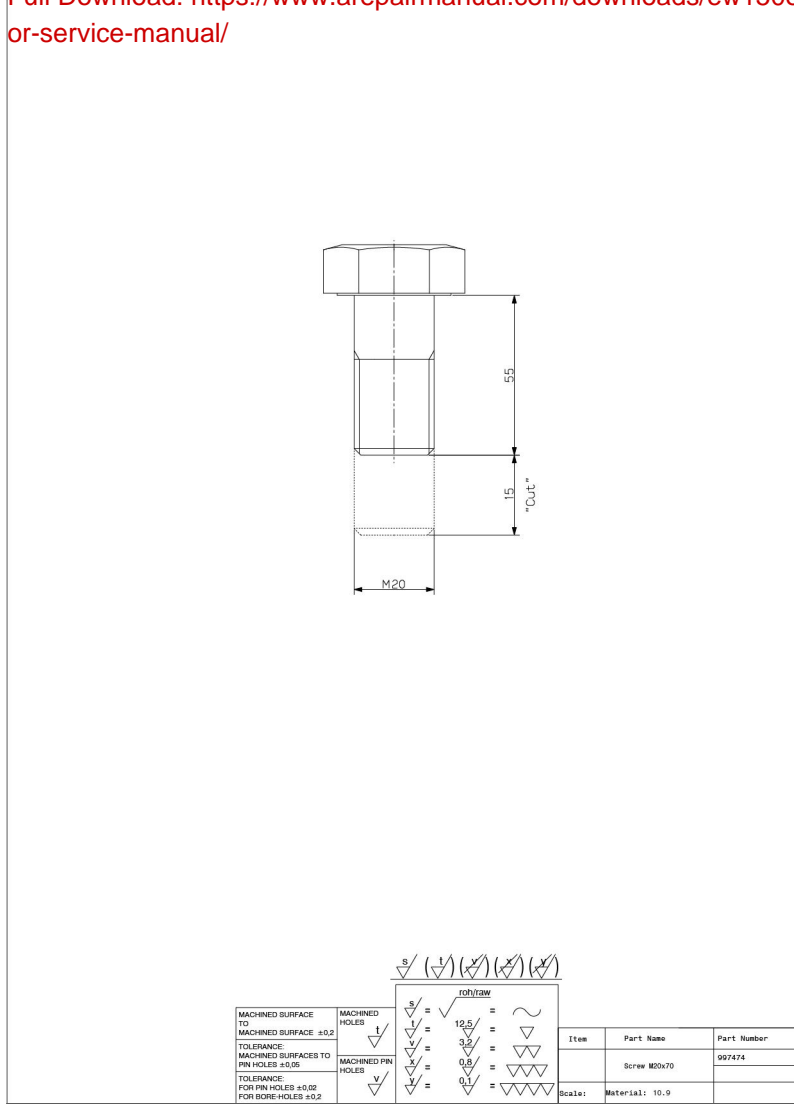

V1231684

Figure 6
Screw M20x70 (cut 15mm off)