

Document Title: Machine view	Function Group: 000	Information Type: Service Information	Date: 3/19/2026
Profile: EC750E L Volvo			

Machine view

Showing Selected Profile

Valid for serial numbers			
Model	Production site	Serial number start	Serial number stop
EC750E L Volvo			

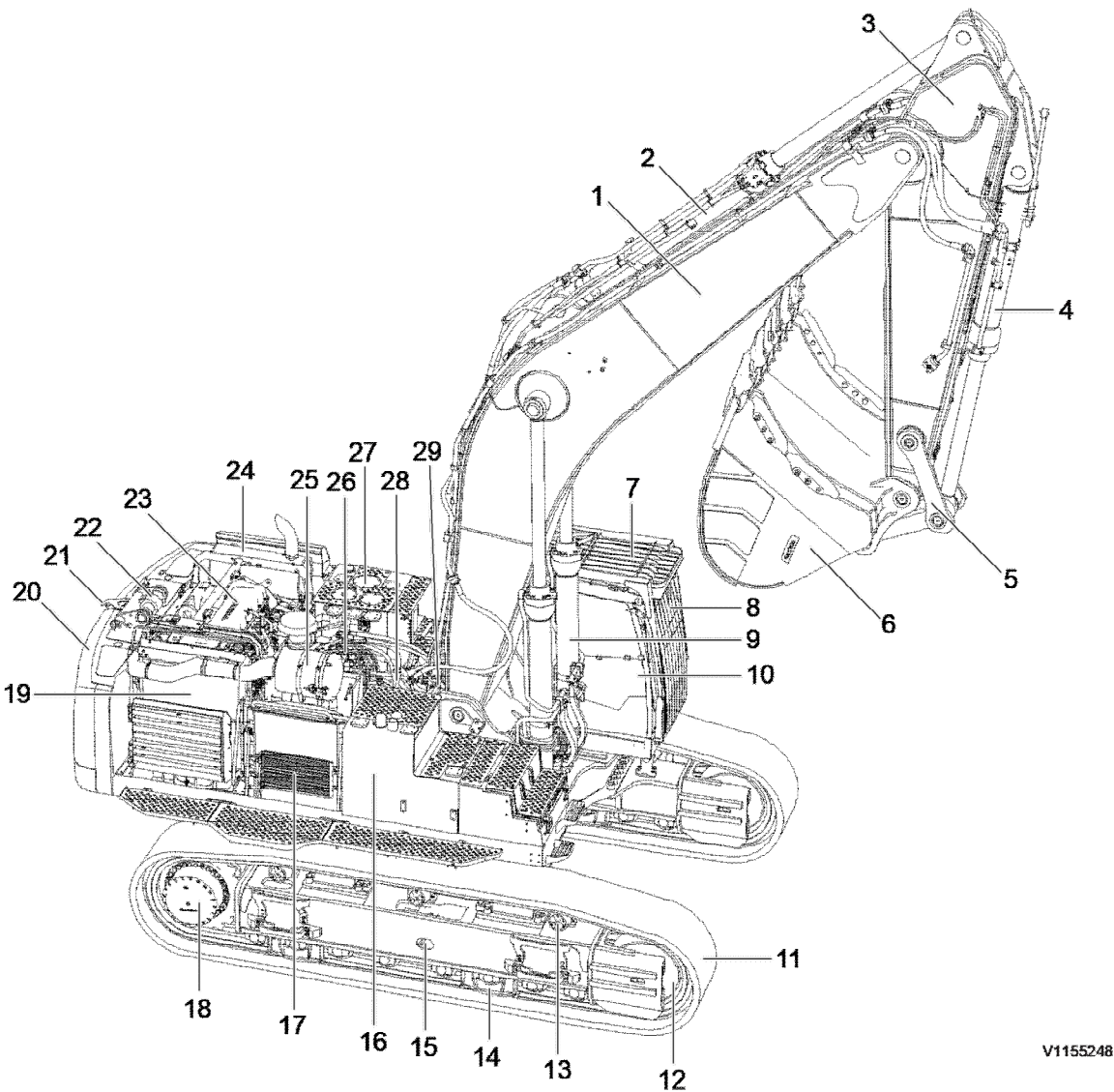

V1155248

Figure 1
Location of components

1	Boom	16	Fuel tank
2	Dipper arm cylinder	17	Air conditioning unit

Product: EC750EL Volvo Excavator Service Manual

Full Download: <https://www.arepairmanual.com/downloads/ec750el-volvo-excavator-service-manual/>

3	Dipper arm	18	Track motor and gearbox
4	Bucket cylinder	19	Radiator and charge air cooler
5	Link	20	Counterweight
6	Bucket	21	Rear view camera
7	FOPS (Falling Object Protection Structure)	22	Removable counterweight support
8	FOG (Falling Object Guard)	23	Engine
9	Boom cylinder	24	Muffler
10	Operator cab	25	Air cleaner
11	Track chain assembly	26	Main control valve
12	Idler	27	Hydraulic tank
13	Top roller	28	Swing motor and gearbox
14	Track guard	29	Center passage
15	Grease nipple		

Sample manual. Download All 3884 pages at:

<https://www.arepairmanual.com/downloads/ec750el-volvo-excavator-service-manual/>

Document Title: Product plates	Function Group: 000	Information Type: Service Information	Date: 3/19/2026
Profile: EC750E L Volvo			

Product plates

Showing Selected Profile

Valid for serial numbers			
Model	Production site	Serial number start	Serial number stop
EC750E L Volvo			

Please refer to the figure below to locate the product plate, engine plate, cab plate and attachment plates. Always use the Product Identification Number (PIN) provided on the vehicle and/or engine plates for troubleshooting purposes and/or when ordering spare parts.

1. Product plate

This plate with Product Identification Number, PIN, for the complete machine indicates the model designation, serial number and when applicable, machine weight, engine power, manufacturing year and CE approval. The plate is positioned on the right side of the upper frame.

Models (General application)

Volvo Crawler excavators and Wheel Excavator are available in different sizes from 5 ton to 95 ton. Some machines can be equipped with different Attachments, Demolition, High Reach Demolition, Pipe Layer, Rotating Pipelayer Kit machine and Dozer blade.

EC	Excavator Crawler	EW	Excavator Wheel
ECR	Excavator Crawler Short-Swing-Radius	AG	Agricultural machines
PL	Pipe Layer	FE	Feller Bunchers
L, LC	Long Crawler	NLD	Narrow Crawler Demolition
N, NC	Narrow Crawler	HR	High Reach Demolition
NL, NLC	Narrow Long Crawler	F, FX	Forestry Application
LM, LCM	Long Crawler Marsh	LD, LCD	Long Crawler Demolition
LR	Long Reach Boom & Arm	LC4	Long Crawler 4
LHDS	Long Crawler Heavy Duty Shanghai	LS	Long Crawler Shanghai
LHDC	Long Crawler Heavy Duty Changwon	NH	Narrow Heavy Duty
LRC4	Long Reach Crawler 4 (Boom & Arm)		

Supplementary PIN plate (EU countries only)

V	C	E	E	C	3	5	C	C	0	0	0	1	2	3	4	5
A			B				C		D							

V1076896

Figure 1

Example of 17 digit PIN number on PIN plate

- A. World Manufacturing Code
- B. Machine description
- C. Check letters
- D. Serial number

The supplementary plate contains information about machine mass in kg, engine net power in Kw, manufacturing year, machine serial number and a CE-mark.

Machine mass

The machine mass in kg on the supplementary PIN plate is based on:

- cab or canopy
- most used track type
- most usual bucket (without load)
- full fuel tank

For safety reasons, 103 % of the machine mass will be shown on the supplementary PIN plate.

2. Engine

The engine type designation, part and serial numbers are stamped on the top of valve cover.

3. Attachment quick coupler

This nameplate is attached on the outside of the bracket and indicates the part number and weight.

4. Bucket

This nameplate is attached on the top of the bucket and indicates the bucket model order number, serial number, bucket part number, rated capacity, weight, cutting width, tooth part number, and adapter part number.

5. Cab

The nameplate is attached on the inside of the cab and indicates the product number, serial number, model type, and weight.

Document Title: Complete machine, assembly instruction	Function Group: 000	Information Type: Service Information	Date: 3/19/2026
Profile: EC750E L Volvo			

Complete machine, assembly instruction

Showing Selected Profile

Valid for serial numbers			
Model	Production site	Serial number start	Serial number stop
EC750E L Volvo			

Precaution

1. Workplace for assembly after transportation
 - Consider area for safety during load and unload machine.
 - Check that flatness, hardness and width of workplace
 - Check that dust and rainwater, etc, to prevent contamination of hydraulic circuit
 - Check weather, do not assembling under strong wind or raining

2. Check that before actual work
 - Apply the brake of the trailer and crane securely and insert block in front and behind their wheels.
 - Use the equipment and tool according to individual national regulations or ISO standard. (ex. crane, lifting cable, ropes, hooks and shacles, etc)
 - Sound the horn and check that no persons are near the machine before you move the machine
 - Check the balance the load , when using the crane

3. Before secure the work, read this instruction thoroughly and keep the precautions in mind.

Transportation

Measurement before transporting machine

NOTICE

The person in charge of the transport must see to that loading, positioning, lashing and transporting the machine on a trailer or other vehicle is done according to applicable laws and regulations for the country or state in question. For further information, contact your dealer.

NOTICE

If vandal protection is installed on the machine, it should be removed before the machine is transported. Check local or national regulations.

Disassembled parts for transportation

Below parts can be disassembled for transportation which are related with transportation in weight and size.

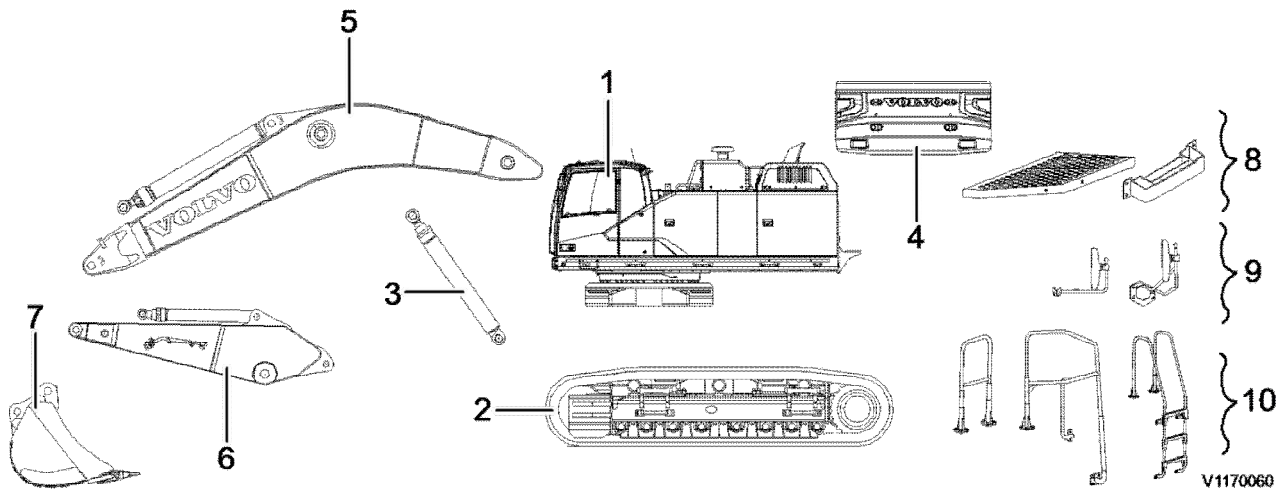

Figure 1

1	Superstructure with lower frame 22400 kg	6	Dipper arm with bucket cylinder 4180 kg
2	Undercarriages 11500 kg	7	Bucket 2459 ~ 5325 kg
3	Boom cylinders 630 kg	8	Walkways and steps 263 kg
4	Counterweight 12700 kg	9	Mirrors
5	Boom with arm cylinder 7450 kg	10	Handrails and guardrails

Total and disassembled specifications, weight and dimension

Weight and dimension are very useful to estimate the method how the disassembled parts are supposed to be transported. To comply with the laws and regulations in certain region, use the specifications of total and disassembled parts.

Track gauge adjustment

Track gauge, retracting

NOTICE

Do not pull in the tracks apart from when transporting. Remove dirt and other debris from the central frame.

1. Position the machine on even, firm and level ground.

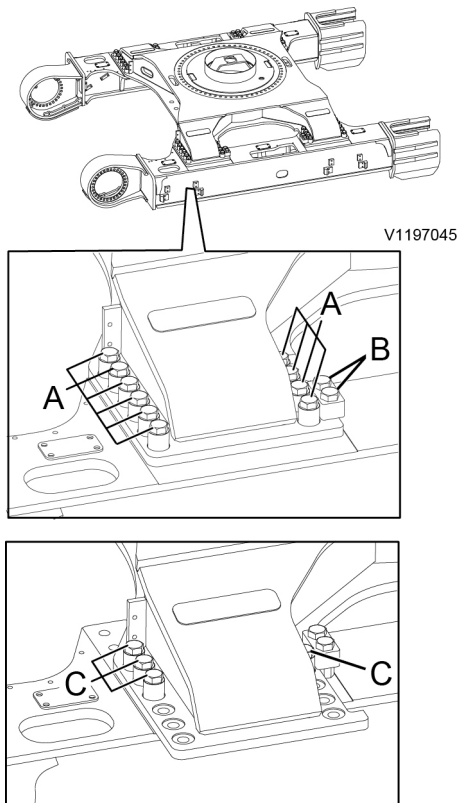

Figure 2

2. Swing the superstructure at a right angle to the track to be retracted.
3. Engine was stopped.
4. Remove the screws (A) of the track frame.

NOTE!

Do not remove the guide screws (B).

5. Apply downward pressure and raise the track frame slowly to about 500 mm (19.7 inch) above ground level. If the track is not readily retracted, rotate the raised track slowly to shake it gently into place.

NOTE!

Do not adjust the track gauge if the angle between boom and dipper arm is below 90°.

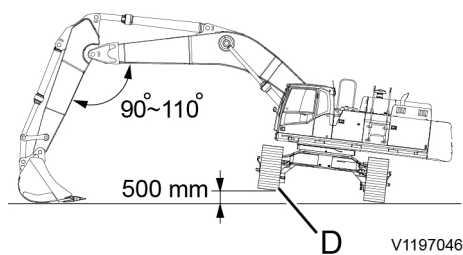

Figure 3

Track to be retracted (D)

6. Lower the track frame to the ground.
7. Align the screw holes and fasten screws (C).

NOTE!

Insert the corks into screw holes to protect the holes from debris and mud.

Apply grease to the hole to protect rust during transporting.

8. Adjust the opposite frame in the same way as above.

Both side retracting should be done.

Track gauge, extending

NOTICE

Remove dirt and other debris that has accumulated on the centre frame.

1. Position the machine on even, firm and level ground.
2. Start the engine and swing the superstructure at a right angle to the opposite track extended.
3. Stop the engine.
4. Remove the screws (C) of the track frame.

NOTE!

Do not remove the guide screws (B).

5. Apply downward pressure and raise the track frame slowly to about 60 mm (2.36 inch) above ground level.

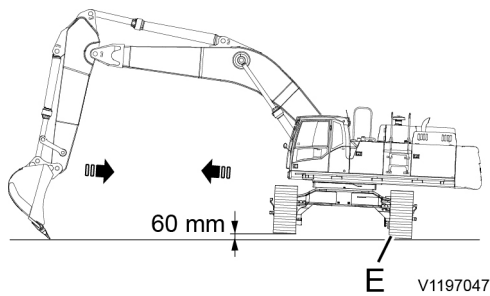

Figure 4

Track to be extended (E)

NOTICE

Do not raise the track frame more than 60 mm (2.36 in) in order not to damage the steering.

6. Pull the machine with the dipper arm and the track will be extended by moving the central frame.
7. Lower the track frame to the ground.
8. Align the screw holes and fasten screws (A).
Tightening torque : 2697 ±294 Nm (275 ±30 kgf m) (1986 ±217 lbf ft)
9. Adjust the opposite frame in the same way as above.
10. Adjust track tension.

Tying down machine

WARNING

Only lift an empty machine. Make sure that no persons are near the machine when it is being lifted.

NOTE!

Make sure that loading ramps and platforms are free from oil, mud, ice and similar so that the machine does not begin to slip.

NOTICE

The function for automatic idling must be deactivated with the button on the keyboard in order to avoid that the speed increases during loading and unloading of the machine.

NOTICE

Select low engine speed and low travelling speed for loading and unloading the machine.

NOTE!

Lift the counterweight just a little, and after confirming safety and horizontal position, proceed to install it.

1. Place the trailer on a firm and level ground.

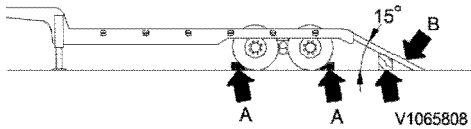

Figure 5

2. Apply the brake of the trailer.
3. Insert blocks (A) in front of and behind the tyres of trailer.
4. Fix loading ramps (B) securely.
 - Make sure that the strength, width, length and thickness of the planks are safe for loading.
 - Make sure that the angle of loading ramp is 15° or less.
5. Check whether the right and the left loading ramps are of the same height.
6. Decide the direction and travel slowly onto the loading ramps and trailer bed / platform. Block each track and secure the machine with tie downs of adequate load rating so that the machine cannot move.

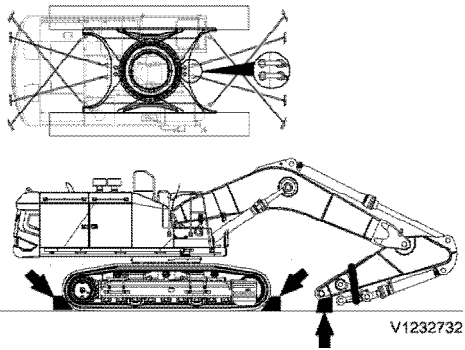

Figure 6

Transport regulation for EN 12195

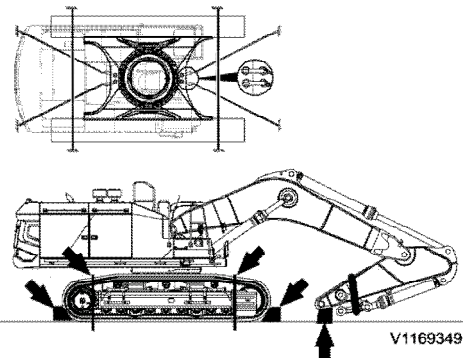

Figure 7

Transport regulation for ISO 15818

- Load the machine so that the bucket cylinder rod does not contact the trailer.
- Never operate any lever other than the travel levers (pedals) while the machine is on the loading ramp.

NOTICE

Do not extend dipper arm or bucket cylinders to their end positions as they then run the risk of being damaged.

NOTE!

Fasten the components for the tough road condition at the arrow point.

7. Stop the machine.
8. When some parts of machine are disassembled, load the disassembled components on the trailers properly. If necessary, put the blocks behind or below the components.

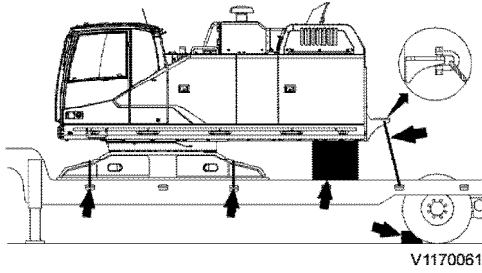

Figure 8

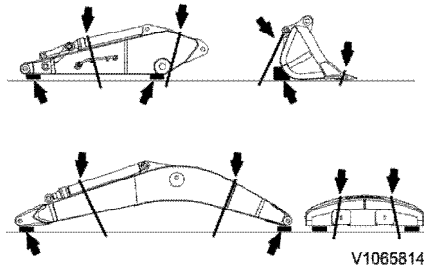

Figure 9

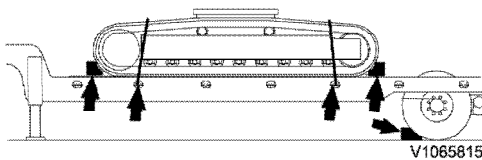

Figure 10

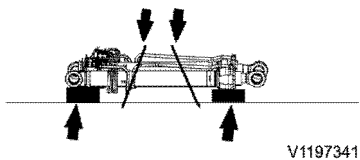

Figure 11

9. Remove the ignition switch.
10. Turn OFF the battery disconnect switch.
11. Lock the door and the access covers.
12. Cover the exhaust pipe to prevent turbocharger from damage due to dust and water.
13. Ensure that the machine or disassembled components are firmly secured.

Dimensions (EC750D)

Total machine, dimension

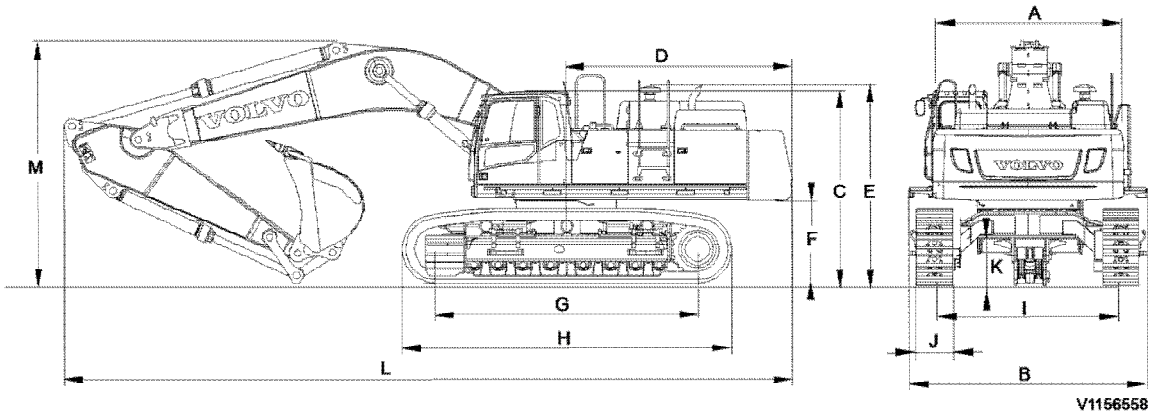

Figure 12

Description (* Without shoe grouser)	Unit	Boom				
		6.6 m 21' 8"	7.1 m 23' 4"	7.7 m 25' 3"		
		Dipper arm				
		2.9 m 9' 6"	2.9 m 9' 6"	2.9 m 9' 6"	3.55 m 11' 8"	
A. Overall width of superstructure	mm ft-in	3420 11'3"	3420 11'3"	3420 11'3"	3420 11'3"	
B. Overall width		4286 14'1"	4286 14'1"	4286 14'1"	4286 14'1"	
C. Overall height of cab		3520 11'7"	3520 11'7"	3520 11'7"	3520 11'7"	
D. Tail swing radius		4140 13'7"	4140 13'7"	4140 13'7"	4140 13'7"	
E. Overall height of engine hood including aircleaner		3590 11'9"	3590 11'9"	3590 11'9"	3590 11'9"	
E. Overall height of engine hood excluding aircleaner		3310 10'10"	3310 10'10"	3310 10'10"	3310 10'10"	
F. *Counterweight clearance		1507 4'11"	1507 4'11"	1507 4'11"	1507 4'11"	
G. Tumbler length		4750 15'7"	4750 15'7"	4750 15'7"	4750 15'7"	
H. Track length		5990 19'8"	5990 19'8"	5990 19'8"	5990 19'8"	
I. Track gauge (extended)		3440 11'3"	3440 11'3"	3440 11'3"	3440 11'3"	
I. Track gauge (retracted)		2750 9'0"	2750 9'0"	2750 9'0"	2750 9'0"	
J. Shoe width		mm in	650 2'2"	650 2'2"	650 2'2"	650 2'2"
K. *Min. ground clearance		mm ft-in	858 2'10"	858 2'10"	858 2'10"	858 2'10"
L. Overall length		12200 40'0"	12700 41'8"	13320 43'8"	13220 43'4"	
M. Overall height of boom		4855 15'11"	4800 15'9"	4660 15'3"	4600 15'1"	

Disassembled parts, dimension

Boom with dipper arm cylinder

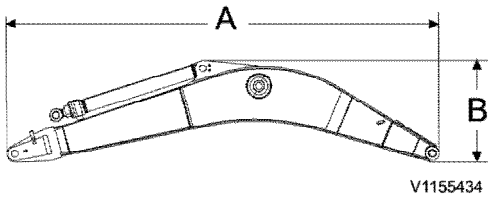

Figure 13

Description	Unit	Boom		
		6.6 m 21' 8"	7.1 m 23' 4"	7.7 m 25' 3"
Length (A)	mm ft-in	6940 22'9"	7440 24'5"	8040 26'4"
Height (B)		2530 8'3"	2430 7'11"	2210 7'3"
Width		1100 3'7"	1100 3'7"	1100 3'7"
Weight	kg	7130	7380	7450
	lb	15719	16270	16424

Dipper arm with bucket cylinder and link

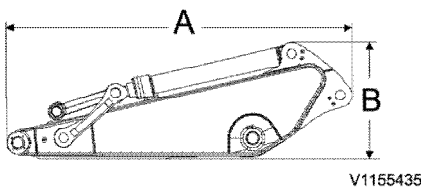
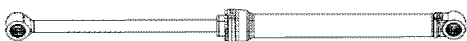

Figure 14

Description	Unit	Dipper arm	
		2.9 m 9' 6"	3.55 m 11' 8"
Length (A)	mm ft-in	4280 14'0"	4960 16'3"
Height (B)		1530 5'0"	1410 4'7"
Width		740 2'5"	740 2'5"
Weight	kg	4050	4180
	lb	8929	9215

Boom cylinders



V1155436

Figure 15

Description	Unit	Boom cylinder
Length	mm ft-in	2525 8'3"
Height		560 1'10"
Width		370 1'2"
Weight (each)	kg lb	630 1388

Counterweight

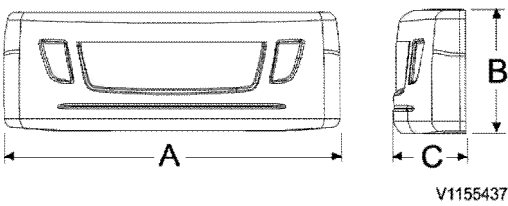

Figure 16

Description	Unit	Counterweight
		12700 kg 28000lb
Length (A)	mm ft-in	3420 11' 2"
Height (B)		1280 4' 2"
Width (C)		800 2' 7"
Weight	kg lb	12700 27998

Track

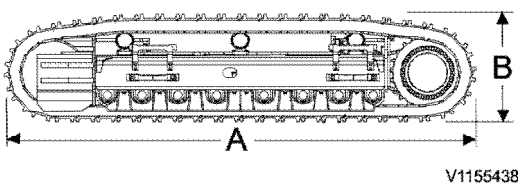

Figure 17

Description	Unit	Shoe		
		650 mm (2'2")	750 mm (2'6")	900 mm (2'11")
Length (A)	mm ft-in	5990 19'7"	5990 19'7"	5990 19'7"

Width		1080 3'6"	1080 3'6"	1160 3'6"
Height (B)		1375 4'6"	1375 4'6"	1375 4'6"
Weight (each)	kg lb	10600 23369	10950 24140	11500 25353

Superstructure

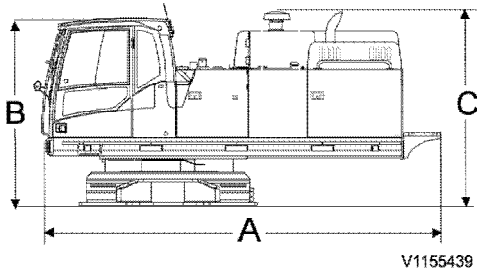

Figure 18

Description	Unit	Superstructure
Length (A)	mm ft-in	5600 18'4"
Height of cab (B)		2655 8'8"
Height of aircleaner (C)		2735 8'11"
Width		3430 11'3"
Weight	kg lb	22400 49383

Superstructure with tracks

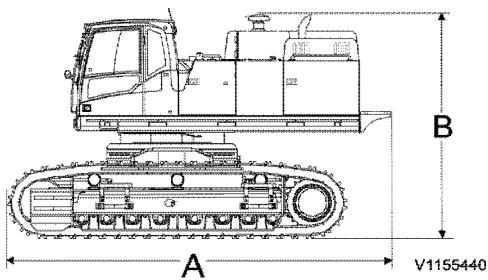
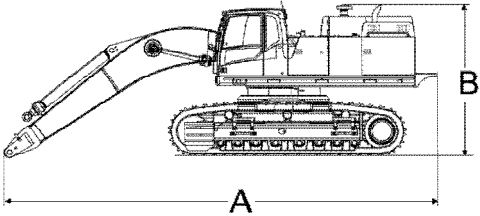

Figure 19

Description	Unit	Tracks (retracted)		
		Shoe 650 mm (2'2")	Shoe 750 mm (2'6")	Shoe 900 mm (2'11")
Length (A)	mm ft-in	6830 22'4"	6830 22'4"	6830 22'4"
Height of aircleaner (B)		3590 11'9"	3590 11'9"	3590 11'9"

Overall width		3495 11'5"	3500 11'5"	3650 11'11"
Weight	kg	43600	44300	45400
	lb	96120	97663	100088

Superstructure with tracks and boom (including cylinders)



V1155441

Figure 20

Description	Unit	Boom 6.6 m		
		Shoe 650 mm (2'2")	Shoe 750 mm (2'6")	Shoe 900 mm (2'11")
Length (A)	mm ft-in	10240 33'7"	10240 33'7"	10240 33'7"
Height of aircleaner (B)		3590 11'9"	3590 11'9"	3590 11'9"
Overall width (Track retracted)		3495 11'5"	3500 11'5"	3650 11'11"
Weight	kg	51990	52690	53790
	lb	114617	116160	118585

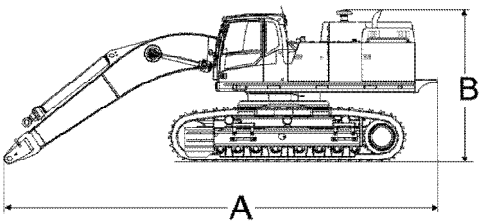

V1155441

Figure 21

Description	Unit	Boom 7.1 m		
		Shoe 650 mm (2'2")	Shoe 750 mm (2'6")	Shoe 900 mm (2'11")
Length (A)	mm ft-in	10770 35'4"	10770 35'4"	10770 35'4"
Height of aircleaner (B)		3590 11'9"	3590 11'9"	3590 11'9"
Overall width (Track retracted)		3495 11'5"	3500 11'5"	3650 11'11"
Weight	kg	52240	52940	54040

lb	115168	116711	119136
----	--------	--------	--------

Description	Unit	Boom		
		7.7 m	Shoe 650 mm (2'2")	Shoe 750 mm (2'6")
Length (A)	mm ft-in	11400 37'4"	11400 37'4"	11400 37'4"
Height of aircleaner (B)		3590 11'9"	3590 11'9"	3590 11'9"
Overall width (Track retracted)		3495 11'5"	3500 11'5"	3650 11'11"
Weight	kg	52310	53010	54110
	lb	115322	116865	119290

Dimensions (EC750E)

Total machine, dimension

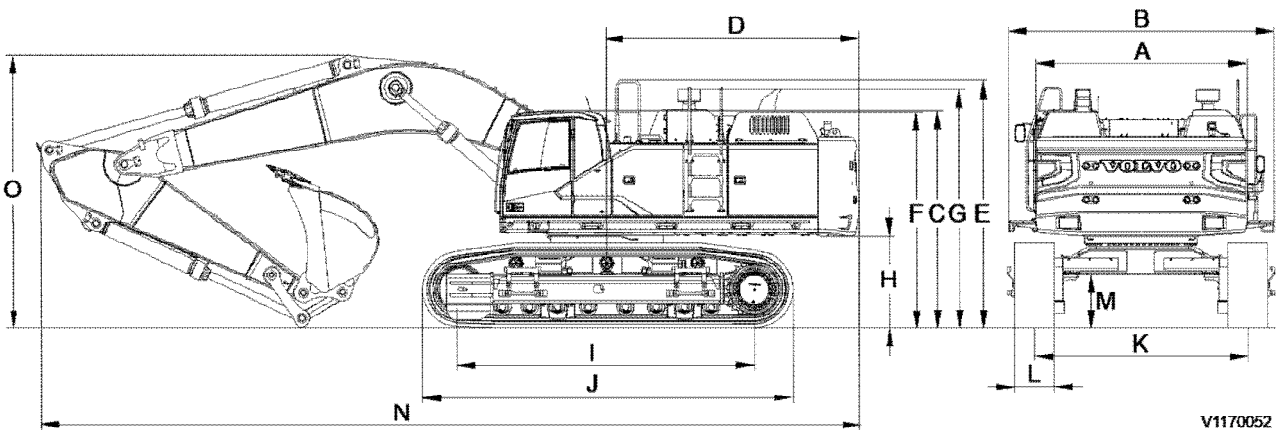

V1170052

Figure 22

Description	Unit	Boom			
		6.6 m (21' 8")	7.7 m (25' 3")	Dipper arm	
		2.9 m (9' 6")	2.9 m (9' 6")	3.55 m (11' 8")	4.2 m (13' 9")
A. Overall width of superstructure	mm ft-in	3420 11' 3"	3420 11' 3"	3420 11' 3"	3420 11' 3"
B. Overall width		4286 14' 1"	4286 14' 1"	4286 14' 1"	4286 14' 1"
C. Overall height of cab		3520 11' 7"	3520 11' 7"	3520 11' 7"	3520 11' 7"
D. Tail swing radius		4140 13' 7"	4140 13' 7"	4140 13' 7"	4140 13' 7"
E. Overall height of guardrail		4000 13' 2"	4000 13' 2"	4000 13' 2"	4000 13' 2"
F. Overall height of engine hood		3540 11' 7"	3540 11' 7"	3540 11' 7"	3540 11' 7"
G ₁ . Overall height of diffuser		3850	3850	3850	3850

	12' 8"	12' 8"	12' 8"	12' 8"
G ₂ . Overall height of rain cap	3790 12' 5"	3790 12' 5"	3790 12' 5"	3790 12' 5"
G ₃ . Overall height of cyclone	3850 12' 8"	3850 12' 8"	3850 12' 8"	3850 12' 8"
G ₄ . Overall height of oil bath	4100 13' 5"	4100 13' 5"	4100 13' 5"	4100 13' 5"

H. *Counterweight clearance	mm ft-in	1507 4' 11"	1507 4' 11"	1507 4' 11"	1507 4' 11"
I. Tumbler length		4750 15' 7"	4750 15' 7"	4750 15' 7"	4750 15' 7"
J. Track length		5990 19' 8"	5990 19' 8"	5990 19' 8"	5990 19' 8"
K. Track gauge (extended)		3440 11' 3"	3440 11' 3"	3440 11' 3"	3440 11' 3"
K ₁ . Track gauge (retracted)		2750 9' 0"	2750 9' 0"	2750 9' 0"	2750 9' 0"
L. Shoe width	mm in	650 26"	650 26"	650 26"	650 26"
M. *Min. ground clearance	mm ft-in	858 2' 10"	858 2' 10"	858 2' 10"	858 2' 10"
N. Overall length		12200 40' 0"	13320 43' 8"	13320 43' 8"	13160 43' 2"
O. Overall height of boom		4855 15' 11"	4660 15' 4"	4660 15' 4"	4950 16' 3"

* Without shoe grouser

Disassembled parts, dimension

Counterweight, dimension

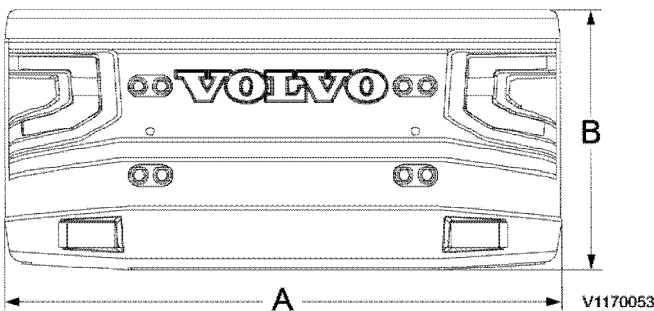

Figure 23

Description	Unit	Counterweight
		12100 kg (26680 lb)
Length (A)	mm	3420 (11' 3")
Height (B)	(ft in)	1750 (5' 9")
Width		660 (2' 2")
Weight	kg (lb)	12100 (26680)

Track (each), dimension

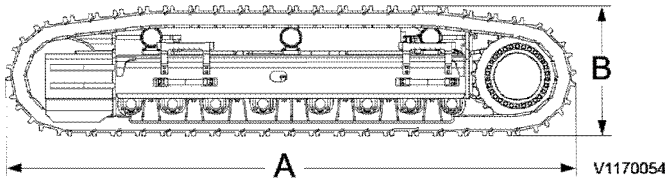

Figure 24

Description	Unit	Shoe width		
		650 mm (26")	750 mm (30")	900 mm (35")
Length (A)	mm	5990 (19' 8")	5990 (19' 8")	5990 (19' 8")
Height (B)	(ft in)	1375 (4' 6")	1375 (4' 6")	1375 (4' 6")
Overall width		1080 (3' 7")	1080 (3' 7")	1160 (3' 10")
Weight	kg (lb)	10600 (23369)	10950 (24140)	11500 (25352)

Boom cylinder (each), dimension



Figure 25

Description	Unit	Boom cylinder
Length	mm	2525 (8' 3")
Height	(ft in)	560 (1' 10")
Width		370 (1' 3")
Weight	kg (lb)	710 (1565)

Boom, dimension

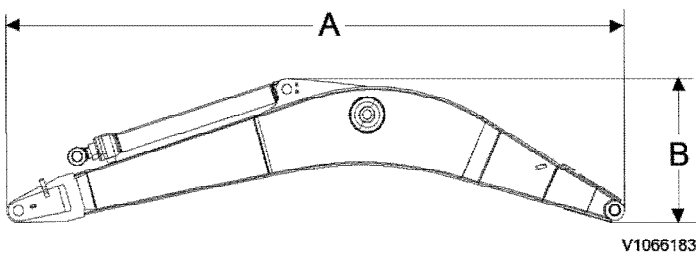

Figure 26

Description	Unit	Boom	
		6.6 m (21' 8")	7.7 m (25' 3")
Length (A)	mm	6490 (21' 4")	8040 (26' 5")
Height (B)	(ft in)	2530 (8' 4")	2210 (7' 3")
Width		1100 (3' 7")	1100 (3' 7")

Weight	kg (lb)	7320 (16138)	7710 (16997)
--------	---------	--------------	--------------

* Includes cylinder, piping and pin

Dipper arm, dimension

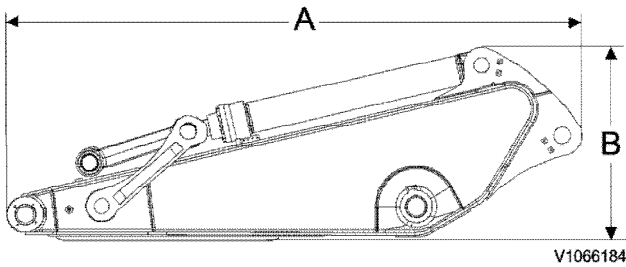

Figure 27

Description	Unit	Dipper arm		
		2.9 m (9' 6")	3.55 m (11' 8")	4.25 m (13' 9")
Length (A)	mm	4280 (14' 1")	4960 (16' 3")	5600 (18' 5")
Height (B)	(ft in)	1530 (5' 0")	1410 (4' 8")	1380 (4' 6")
Width		740 (2' 5")	740 (2' 5")	740 (2' 5")
Weight	kg (lb)	4120 (9083)	4210 (9281)	4520 (9965)

* Includes cylinder, linkage and pin

Superstructure, dimension

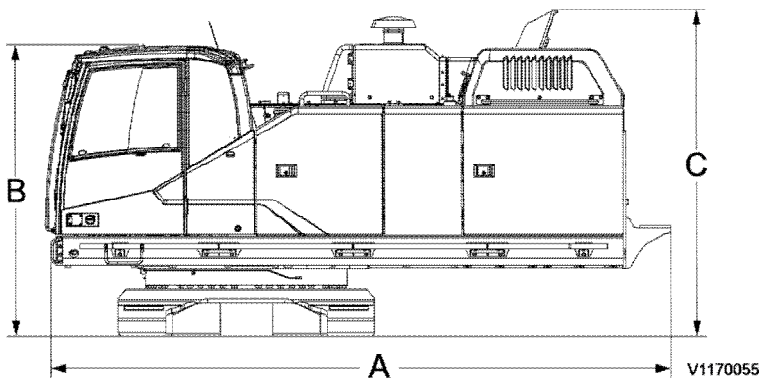

Figure 28

Description	Unit	Superstructure
Length (A)	mm	5500 (18' 1")
Height of cab (B)	(ft in)	2655 (8' 9")
Height of diffuser (C)		2995 (9' 10")
Width		3430 (11' 3")
Weight	kg (lb)	23150 (51036)

Superstructure with tracks, dimension

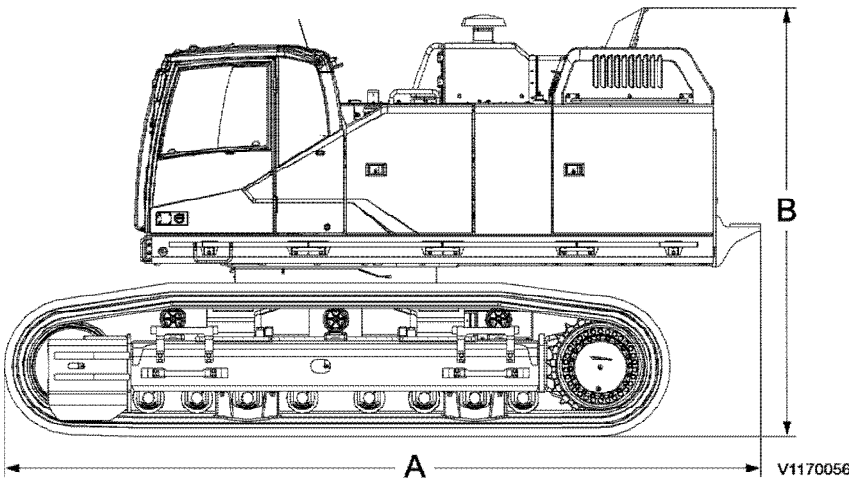

Figure 29

Description	Unit	Shoe width		
		650 mm (26")	750 mm (30")	900 mm (35")
Length (A)	mm	6780 (22' 3")	6780 (22' 3")	6780 (22' 3")
Height of diffuser (B)	(ft in)	3850 (12' 8")	3850 (12' 8")	3850 (12' 8")
Overall width (retracted)		3495 (11' 6")	3500 (11' 6")	3650 (11' 7")
Weight	kg (lb)	44350 (97774)	45050 (99317)	46150 (101742)

Superstructure with tracks and boom (including cylinders), dimension

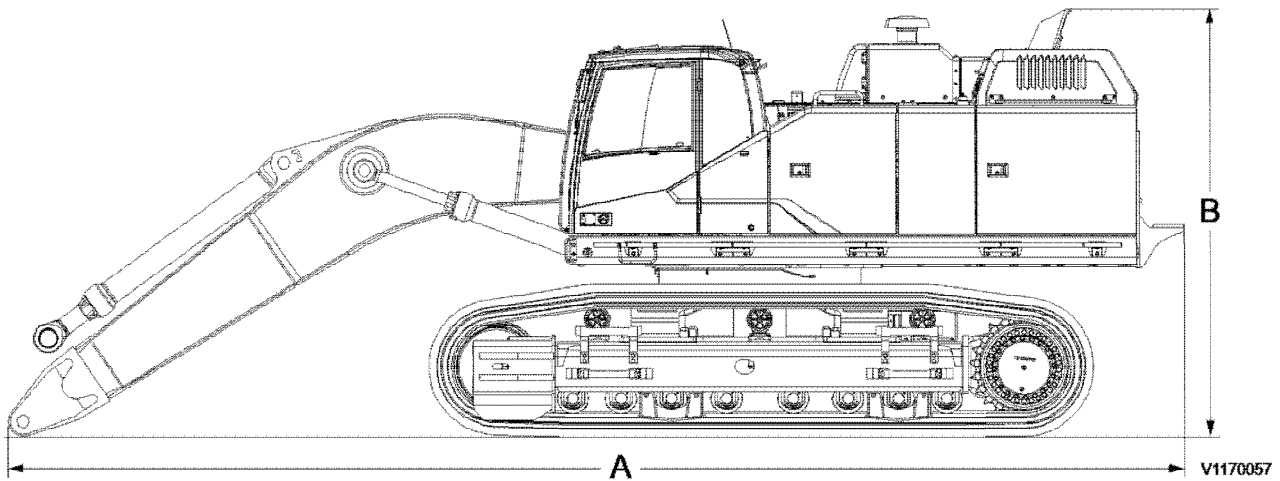
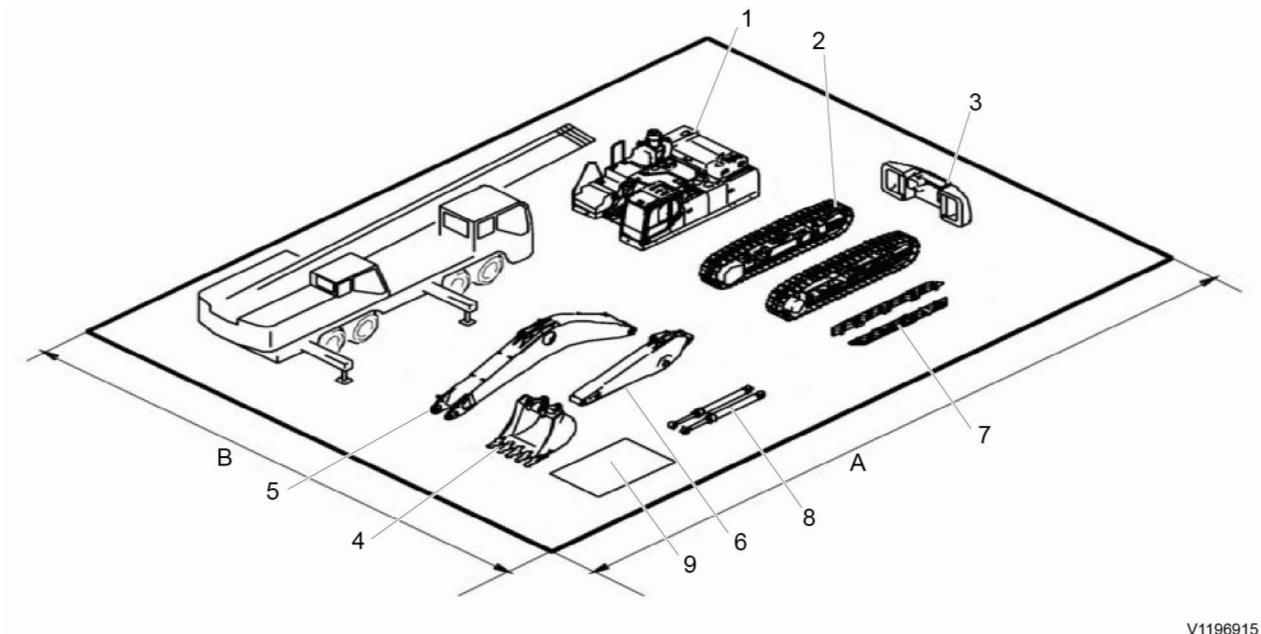

Figure 30

Description	Unit	Boom 6.6 m (21' 8")		
		Shoe width		
		650 mm (26")	750 mm (30")	900 mm (35")
Length (A)	mm	10190 (33' 5")	10190 (33' 5")	10190 (33' 5")
Height of diffuser (B)	(ft in)	3850 (12' 8")	3850 (12' 8")	3850 (12' 8")
Overall width (retracted)		3495 (11' 6")	3500 (11' 6")	3650 (11' 7")
Weight	kg (lb)	53090 (117042)	53790 (118585)	54890 (121010)

Description	Unit	Boom 7.7 m (25' 3")		
		Shoe width		
		650 mm (26")	750 mm (30")	900 mm (35")
Length (A)	mm	11350 (37' 3")	11350 (37' 3")	11350 (37' 3")
Height of diffuser (B)	(ft in)	3850 (12' 8")	3850 (12' 8")	3850 (12' 8")
Overall width (retracted)		3495 (11' 6")	3500 (11' 6")	3650 (11' 7")
Weight	kg (lb)	53480 (117901)	54180 (119445)	55280 (121870)

Arrangement of major components



V1196915

Figure 31

1. Upper frame assembly with center frame
2. Track side frame assembly
3. Counter weight
4. Bucket assembly
5. Boom assembly
6. Arm assembly
7. Walk way
8. Boom cylinder
9. Hand rail

- A. 35,000 mm (1377.9 inch)
- B. 20,000 mm (787.4 inch)

Safety precautions



Risk of crushing injury.

The hydraulic system could respond slowly at low temperatures and could cause unexpected machine movements.

Operate carefully until the hydraulic system has reached operating temperature.



Hot hydraulic oil and hydraulic oil under pressure may result in severe personal injuries

! WARNING

Lower the digging units to the ground and stop the machine (start switch ON position). Operate the control levers several times to release the remaining pressure in the hydraulic piping.

! WARNING

Risk of high pressure injection.

Residual pressure in the hydraulic system could lead to serious injury. Oil under high pressure can jet out, even if the engine has not been running for some time.

Always release the pressure and ensure the ignition switch is in the off position before you perform any service of the hydraulic system.

NOTICE

Always handle oils and other environmentally hazardous fluids in an environmentally safe manner.

NOTICE

When a hose has been disconnected, plug both the hose and the connection immediately. The hoses should be marked for correct connection.

! WARNING

Risk of personal injury.

Faulty or improper lifting equipment could cause the machine to break away from the lifting vehicle, causing accidents, serious injury or death.

Use certified cables, lifting straps, slings, shackles and hooks with adequate load rating.

! WARNING

The parts are heavy. Take appropriate safety cautions when handling them.

! WARNING

Always use classified cables, lifting straps, shackles and hooks with sufficient lifting capacity.

Install the vacuum pump to prevent oil leak during operations

1. Place the vacuum pump on the hydraulic oil tank.

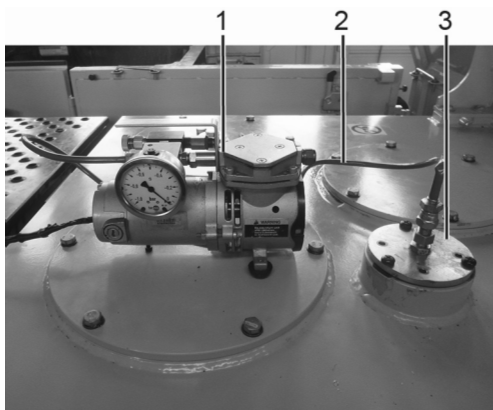

V1169298

Figure 32

Vacuum pump, installing

1. Vacuum pump
2. Hose

3. Adapter

2. Remove the air breather and immediately install the adapter. and connect the hose to the adapter.
3. Connect the plug to the 24 V socket behind the operator's cab.
4. Start the vacuum pump.
5. Run the pump for 2~3 minutes until a negative pressure reading of 30 kPa (4.35 psi) is obtained.
6. Adjust the vacuum pressure with the adjusting knob so that oil leakage will not occur during work on the hydraulic system.

IMPORTANT! The pressure must not fall below 30 kPa (4.35 psi), as otherwise there is a risk of damage to the hydraulic oil tank.

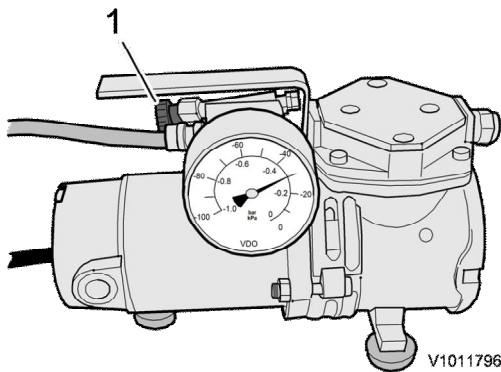

Figure 33
Vacuum pump, installing

1. Adjusting knob

7. Turn off the electric power to the vacuum pump.
8. Remove the plug from the DC 24V socket.
9. Remove the hose from the adapter.
10. Remove the adapter and immediately fit the air breather.

Plugs on hydraulic pipe and hoses

Nipple	No	Part No	Description	Qty	Remarks
ARM/BKT Line on MCV & Boom Att.	1	14531121	PLUG	4	1 1/4", with o-ring groove, Hole
	2	14599492	PLUG_FLANGE	4	1 1/4", w/o o-ring groove, Tab
	3	14882689	O-RING_SQUARE	4	1 1/4"
ARM/BKT Line on Boom Att.	1	14531121	PLUG	4	1 1/4", with o-ring groove, Hole
	2	14882689	O-RING_SQUARE	4	1 1/4"
X3 Line on Boom Att.	1	935574	PLUG_ORFS	4	13/16 UNF (FEMALE)
	2	935486	PLUG_ORFS	4	13/16 UNF (MALE)
	3	4880493	O-RING_12.42X1.78	4	13/16 UNF
Q/Fit line on Boom Att. Q/Fit line on Arm Att.	1	935756	PLUG_ORFS	8	9/16 UNF (FEMALE)
	2	935650	PLUG_ORFS	8	9/16 UNF (MALE)
	3	4881722	O-RING_12.42X1.78	8	9/16 UNF
Boom cyl. Line	1	14531121	PLUG	8	1 1/4", with o-ring groove, Hole
	2	14599492	PLUG_FLANGE	4	1 1/4", w/o o-ring groove, Tab
	3	14882689	O-RING_SQUARE	8	1 1/4"
Arm cyl. Line	1	14531121	PLUG	2	1 1/4", with o-ring groove, Hole
	2	14599492	PLUG_FLANGE	2	1 1/4", w/o o-ring groove, Tab
	3	14882689	O-RING_SQUARE	2	1 1/4"
Bucket cyl. Line	1	14531121	PLUG	2	1 1/4", with o-ring groove, Hole

	2	14882689	O-RING_SQUARE	2	1 1/4"
X1 line	1	14599492	PLUG_FLANGE	2	1 1/4", w/o o-ring groove, Tab

Bucket, removing

1. Remove the lock screws, plate, cord rings and mounting pin of bucket.
2. Retract the bucket cylinder rod.
3. Remove the lock screw, plate, cord rings and mounting pin of connecting rod.
4. Lift the dipper arm and move to empty space.

NOTE!

Block the remove bucket stabilize. Keep the pin clean.

Bucket, installing

1. Lubricate the mounting pin of bucket.
2. Insert the cord ring on the bucket pin.
3. Install the mounting pin and lock screw of bucket.
4. After starting the engine, extend the bucket cylinder rod.
5. Lubricate the mounting pin of connecting rod.
6. Insert the cord ring on the connecting rod pin.
7. Install the mounting pin and lock screw of connecting rod.

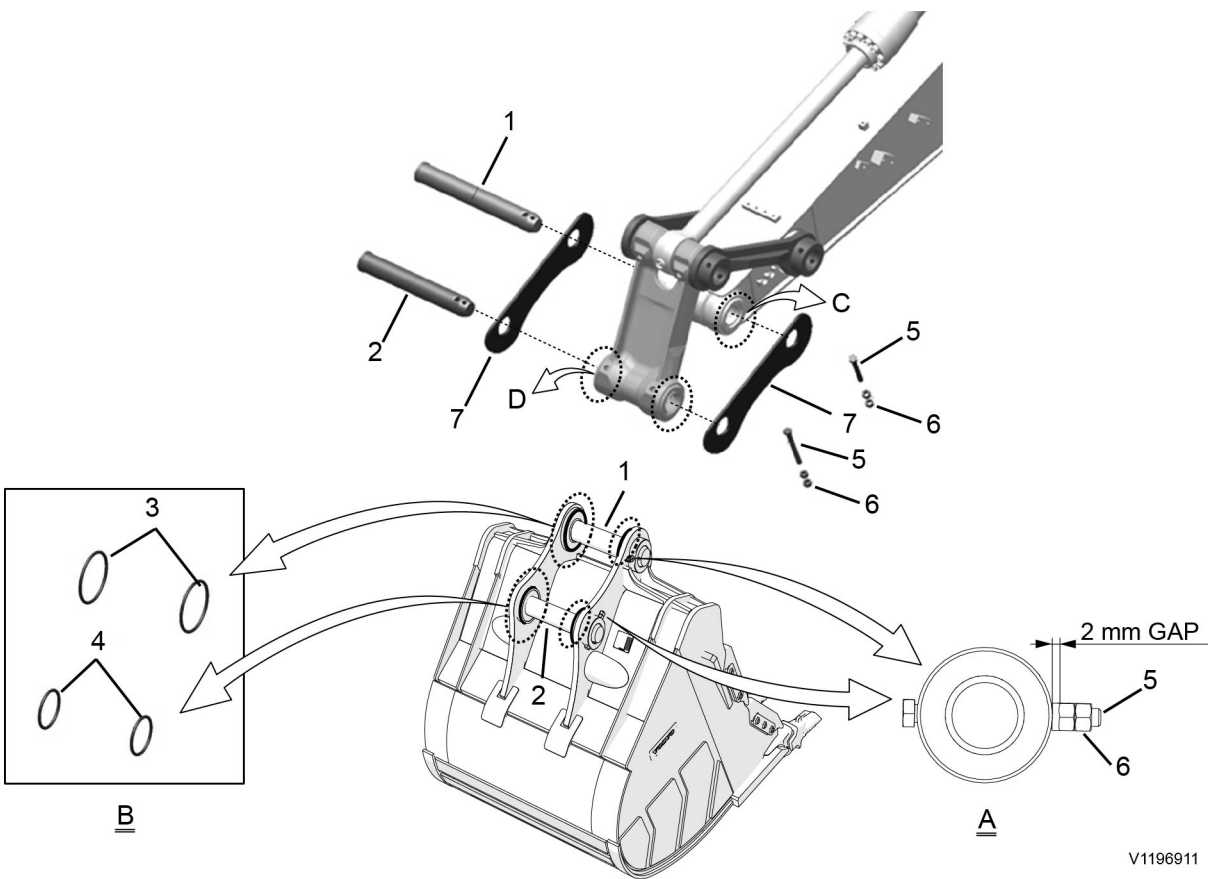

V1196911

Figure 34

Bucket, installing

- A. Clearance between lock screw nut is approximately 2 mm (0.08 inches). And tighten the outer nut by locking the inner nut with spanner.
- B. Cord ring
- C. Gap

Gap and shims: mm (inches)

Items	Gap		Necessary shims for maximum gap	
	Minimum	Maximum	Shim (1 mm) quantity	Shim (0.5 mm) quantity
GAP (C)	+0.50 (0.002)	+2.00 (0.008)	-	-

1. Bucket pin
2. Connecting rod pin
3. Code rings
4. Code rings
5. Lock screws (Tightening torque: 511.9 Nm (52.2 ±5.2 kgf m) (376.9 lbf ft))
6. Nuts
7. Plate for recycle

Dipper arm, removing

1. Disconnect the hydraulic hoses of bucket cylinder.
2. Disconnect the hydraulic hoses of X1.
3. Disconnect the hydraulic hoses of UQC (Universal Quick coupler).
4. Retract the dipper arm cylinder rod.
5. After starting the engine, change the dipper arm service position. Place the wooden block under the dipper arm.
6. Hold the dipper arm cylinder with hoist.
7. Disconnect the grease hose.
8. Remove the lock screws and mounting pin of dipper arm cylinder rod.
9. Retract the dipper arm cylinder rod and tie it with rope for prevent oil leak from the main circuit.
10. Remove the mounting pin of dipper arm.
11. Lift the dipper arm and move to empty space.

Dipper arm, cylinder rod, installing

1. Hold the dipper arm with hoist and move to mounting area slowly.

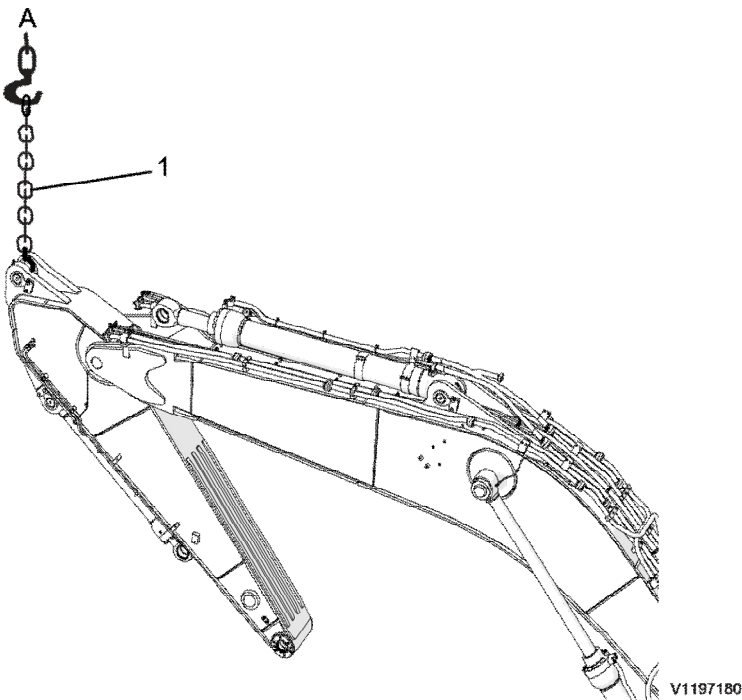

Figure 35

- A. Hanging point
- 1. Hoist
Hoist capacity: 5.5 Ton

2. Insert the shims between D and E of installed dipper arm.
3. Install the mounting pin and lock screw of dipper arm.
4. Hold the dipper arm cylinder with hoist.
5. Start the engine and extend the dipper arm cylinder rod to mounting area.
6. Insert the shims into the surface of installed cylinder rod.
7. Install the mounting pin and lock screw of dipper arm cylinder rod.

NOTE!

The gap (A+B) should be under 1 mm (0.039 inches).

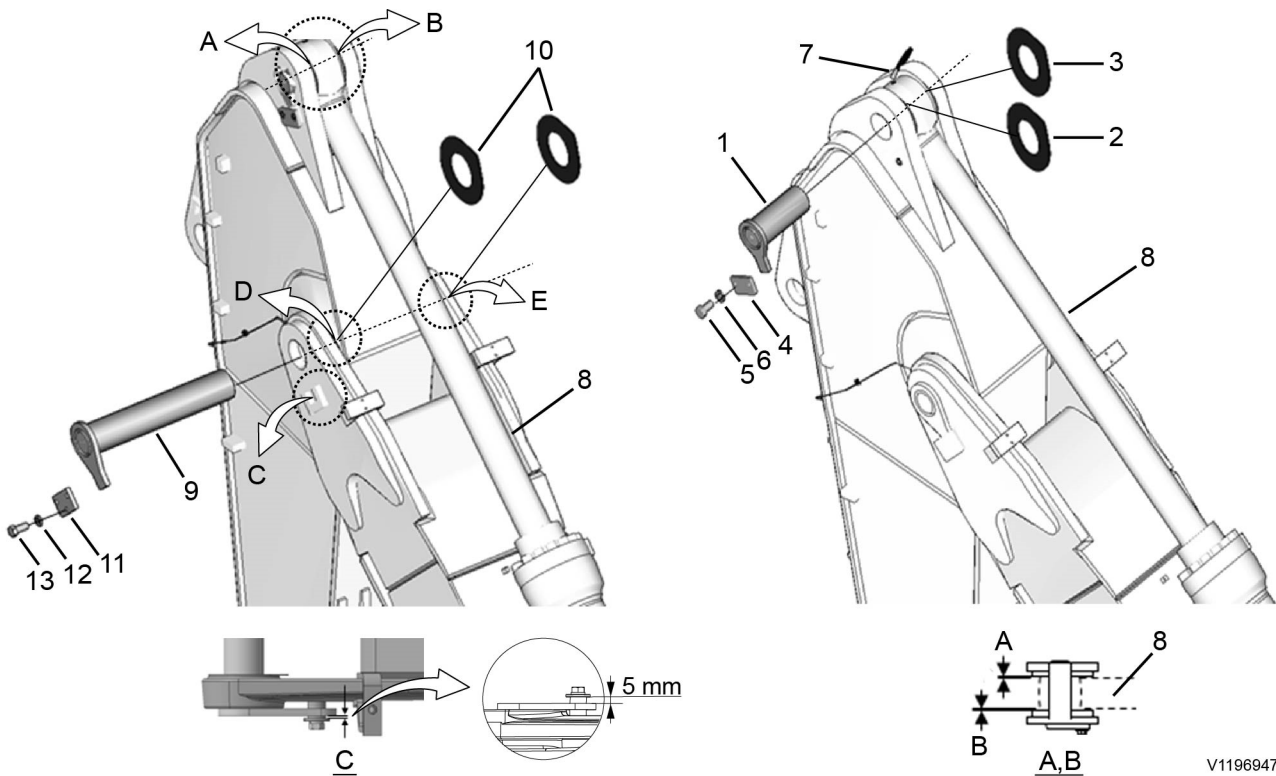

Figure 36

Dipper arm and cylinder rod, installing

- A. Gap
- B. Gap
- C. Gap (5 mm (0.20 inches))
- D. Gap
- E. Gap

Gap and shims: mm (inches)

Items	Gap		Necessary shims for maximum gap	
	Minimum	Maximum	Shim (1 mm) quantity	Shim (0.5 mm) quantity
GAP (A,B)	+0.50 (0.019)	+2.50 (0.098)	1	1
GAP (D,E)	+0.30 (0.012)	+0.90 (0.035)	-	-

1. Dipper arm cylinder rod pin

2. Shim (1 mm) (0.039 inches)
3. Shim (0.5 mm) (0.020 inches)
4. Plate
5. Screw (Tightening torque: 511.9 ±51 Nm (52.2 ±5.2 kgf m) (376.9 ±37.5 lbf ft))
6. Washer
7. Grease hose (Tightening torque: 29.4 Nm (3.0 kgf m) (21.6 lbf ft))
8. Dipper arm cylinder rod
9. Dipper arm pin
10. Shims (2 mm) (0.079 inches)
11. Plate
12. Washer
13. Screw (Tightening torque: 511.9 ±51 Nm (52.2 ±5.2 kgf m) (376.9 ±37.5 lbf ft))

Bucket cylinder hoses and X1 hoses, connecting

1. Connect the hydraulic of bucket cylinder.
2. Connect the hydraulic hose of X1.

NOTE!

Be careful not to damage of assembly part of O-ring itself.

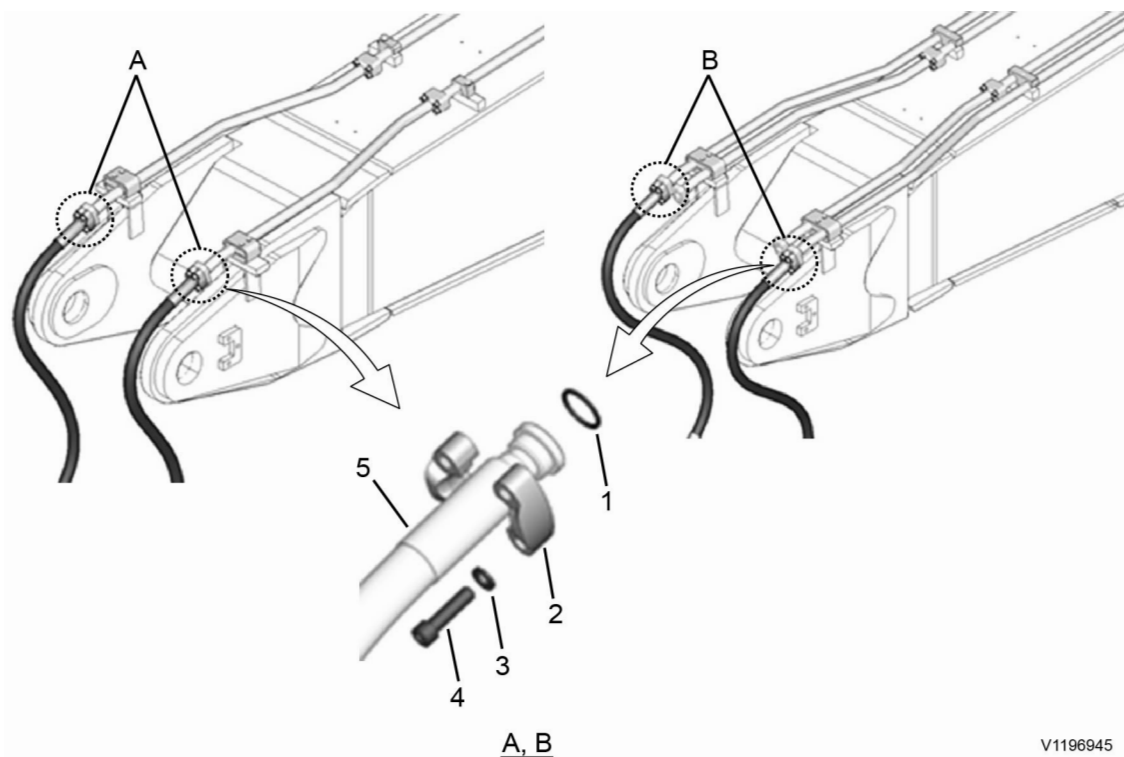

V1196945

Figure 37

Bucket cylinder hoses and X1 hoses, connecting

- A. Bucket cylinder hoses
 - B. X1 hoses
1. O-ring
 2. Flange
 3. Spring washer
 4. Screws (Tightening torque: 175.5 ±17.7 Nm (17.9 ±1.8 kgf m) (129.2 ±13 lbf ft))
 5. Hose

Quick coupler hydraulic hoses, connecting (UQC)

1. Connect the hydraulic hoses of UQC (Universal Quick coupler).

NOTE!

Before to connect, check the marking on end of hose.

NOTE!

- Be careful not to damage of assembly part of O-ring itself.
- Hose and fitting must be assembled after checking the O-ring installed on the position.

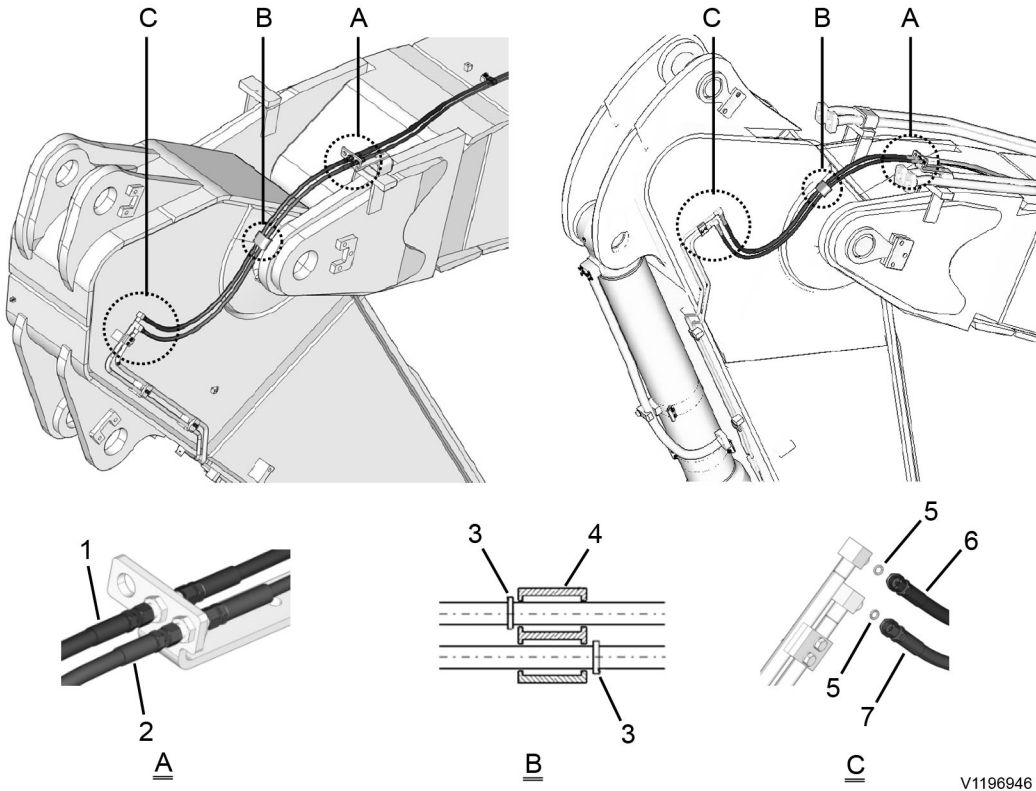

Figure 38

Quick coupler hoses, connecting (UQC)

1. Hoses (From Quick coupler valve)
(Tightening torque: 29.4 ±2.9 Nm (3.0 ±0.3 kgf m) (21.7 ±2.2 lbf ft))
2. Tie
3. Grommet
4. O-ring
5. Hoses (From Quick coupler valve)
(Tightening torque: 29.4 ±2.9 Nm (3.0 ±0.3 kgf m) (21.7 ±2.2 lbf ft))

Main boom, Boom cylinder, removing

1. Remove the lock nut, collar and shims of boom cylinder rod.
2. Hold the boom cylinder with hoist and remove the mounting pin of boom cylinder rod to opposite side.
3. Start the engine, then retract boom cylinder rod fully.
4. Disconnect the hydraulic hoses of boom cylinder and plug for prevent oil leaking.
5. Remove the mounting pin and boom cylinder.
6. Carry out the same work with opposite boom cylinder.
7. Disconnect the hydraulic hoses of X1 and connector of wiring harness.
8. Disconnect the hydraulic hoses of bucket cylinder.
9. Disconnect the hydraulic hoses of dipper arm cylinder.
10. Disconnect the grease hose of boom cylinder rod.
11. Disconnect the connect of wiring harness.

12. Install the collar and lock screw, then hold main boom with hoist.
13. Remove the lock screw of main boom mounting pin.
14. Remove the mounting pin of main boom using an impact puller.
15. Lift the boom and move to working place safely.

Main boom, installing

1. Hold the main boom with hoist and prepare lifting.

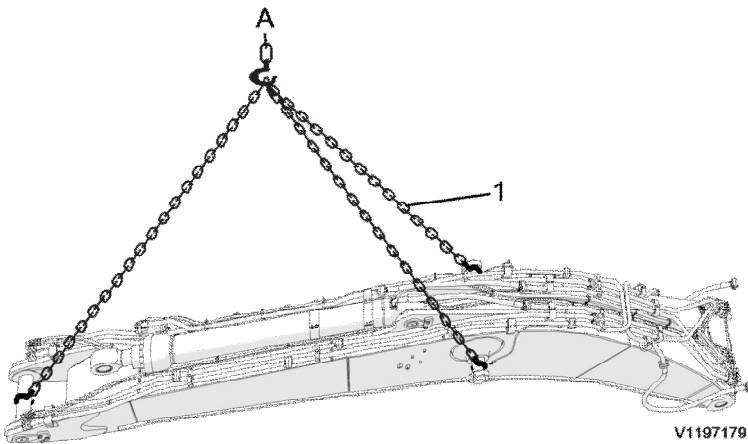

Figure 39

A. Hanging point

1. Hoist
Hoist capacity: 8.5 Ton

2. Move the main boom to mounting area slowly.
3. Insert the shims into the surface of installed boom.
4. Install the mounting pin of main boom using an impact puller.
5. Install the lock screw of main boom mounting pin.

NOTE!

The gap (A+B) should be under 0.7 mm (0.028 inches).

Special tool:

14033320 Impact puller

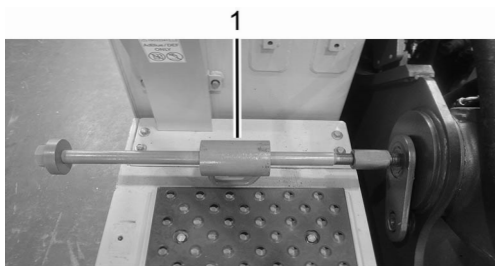

V1197177

Figure 40

1. Impact puller

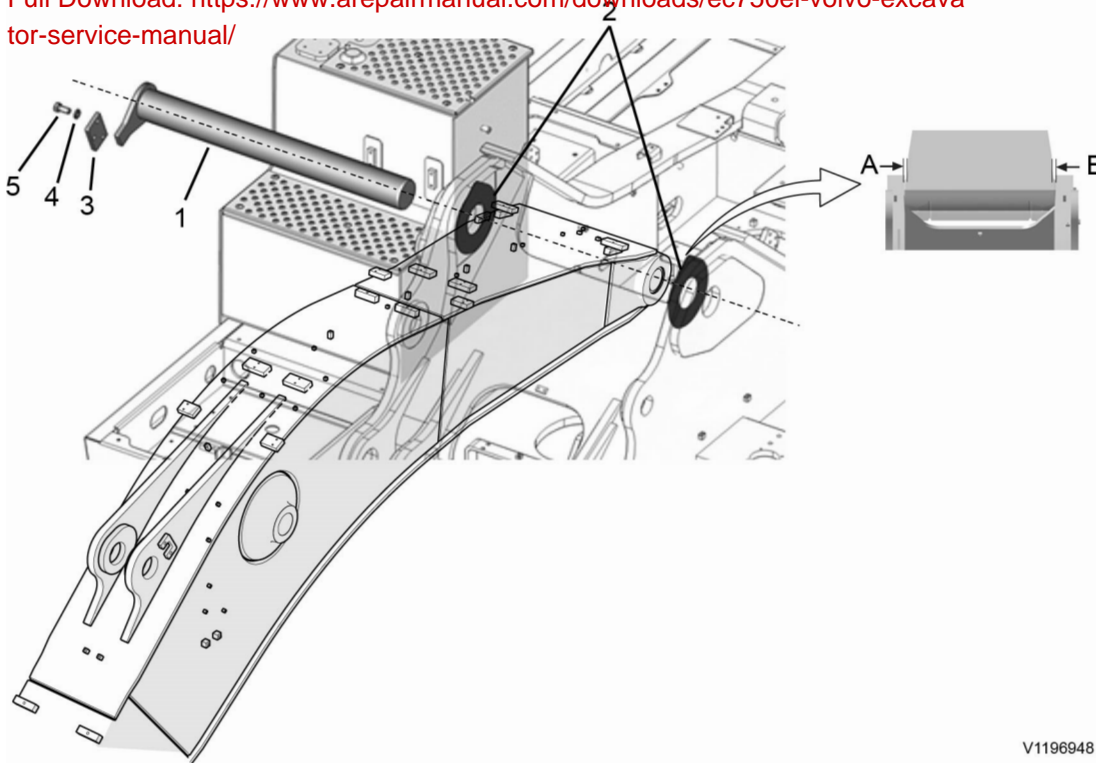

V1196948

Figure 41
 Main boom, installing

- A. Gap
- B. Gap

Gap and shims: mm (inches)

Items	Gap		Necessary shims for maximum gap	
	Minimum	Maximum	Shim (1 mm) quantity	Shim (0.5 mm) quantity
GAP (A,B)	+0.15 (0.006)	+1.00 (0.040)	-	-

1. Main boom pin
2. Shims (2 mm) (0.079 inches)
3. Plate
4. Washer
5. Screw (Tightening torque: 511.9 ±51 Nm (52.2 ±5.2 kgf m) (376.9 ±37.5 lbf ft))

Main boom hydraulic hoses, connecting

1. Connect the hydraulic hoses of X1.
2. Connect the hydraulic hoses of bucket cylinder.
3. Connect the hydraulic hoses of dipper arm cylinder.
4. Connect the connector of wiring harness.