

Document Title: Machine view	Function Group: 000	Information Type: Service Information	Date: 3/7/2026
Profile: EC350D Volvo			

Machine view

Showing Selected Profile

Valid for serial numbers			
Model	Production site	Serial number start	Serial number stop
EC350D Volvo			

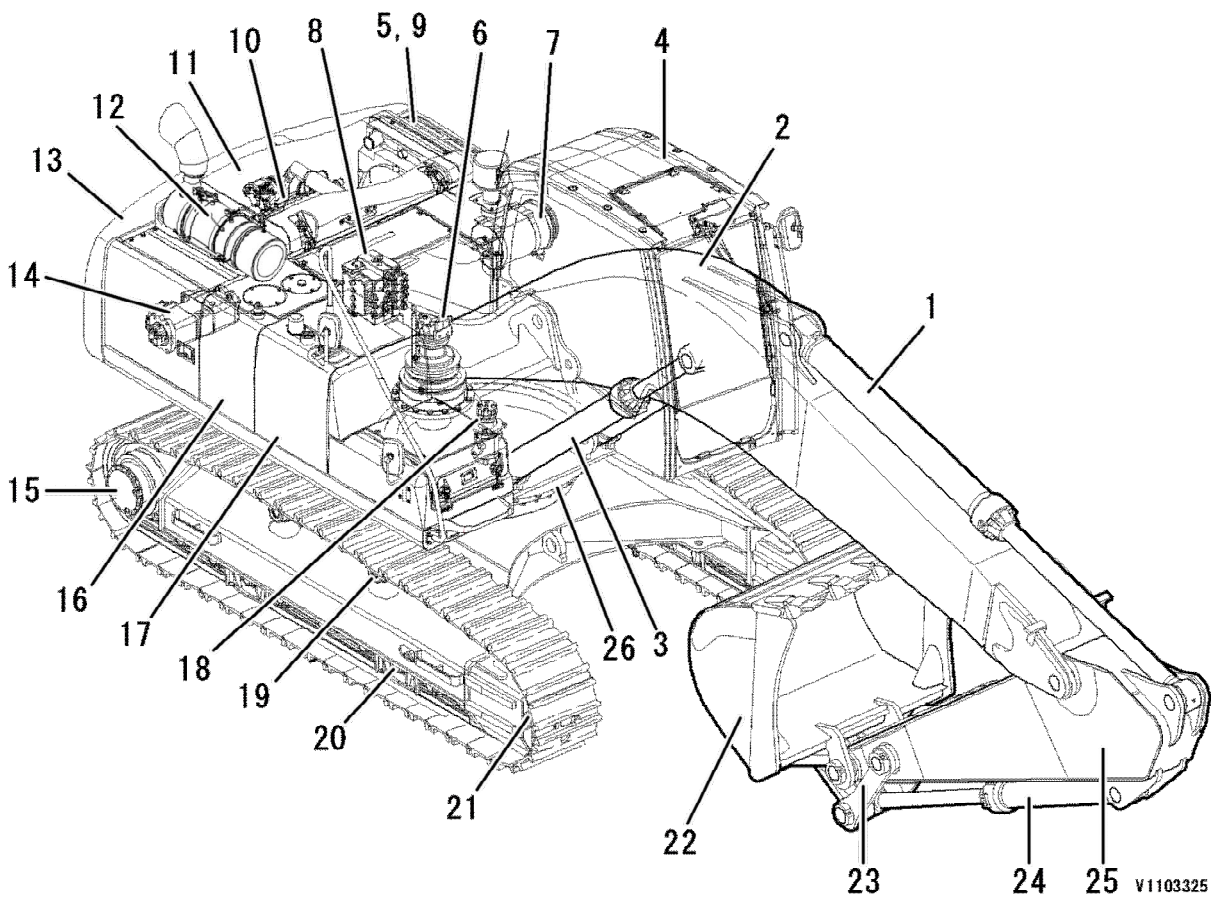

Figure 1

1	Dipper arm cylinder	14	Main pump
2	Boom	15	Track motor and gearbox
3	Boom cylinder	16	Hydraulic tank
4	Operator cab	17	Fuel tank
5	Hydraulic oil cooler	18	Center passage
6	Swing motor and gearbox	19	Top roller
7	Air cleaner	20	Bottom roller
8	Swing bearing	21	Idler
9	Swing bearing		
10	Swing bearing		
11	Swing bearing		
12	Swing bearing		
13	Swing bearing		
22	Swing bearing		
23	Swing bearing		
24	Swing bearing		
25	Swing bearing		
26	Swing bearing		

Product: EC350D Volvo Excavator Service Manual

Full Download: <https://www.arepairmanual.com/downloads/ec350d-volvo-excavator-service-manual/>

9	Radiator and Charged air cooler	22	Bucket
10	Engine	23	Link
11	Rear hood	24	Bucket cylinder
12	Muffler	25	Dipper arm
13	Counterweight	26	Swing ring gear

Sample manual. Download All 2405 pages at:

<https://www.arepairmanual.com/downloads/ec350d-volvo-excavator-service-manual/>

Document Title: Product plates	Function Group: 000	Information Type: Service Information	Date: 3/7/2026
Profile: EC350D Volvo			

Product plates

Showing Selected Profile

Valid for serial numbers			
Model	Production site	Serial number start	Serial number stop
EC350D Volvo			

Please refer to the figure below to locate the product plate, engine plate, cab plate and attachment plates. Always use the Product Identification Number (PIN) provided on the vehicle and/or engine plates for troubleshooting purposes and/or when ordering spare parts.

1. Product plate

This plate with Product Identification Number, PIN, for the complete machine indicates the model designation, serial number and when applicable, machine weight, engine power, manufacturing year and CE approval. The plate is positioned on the right side of the upper frame.

Models (General application)

Volvo Crawler excavators and Wheel Excavator are available in different sizes from 5 ton to 95 ton. Some machines can be equipped with different Attachments, Demolition, High Reach Demolition, Pipe Layer, Rotating Pipelayer Kit machine and Dozer blade.

EC	Excavator Crawler	EW	Excavator Wheel
ECR	Excavator Crawler Short-Swing-Radius	AG	Agricultural machines
PL	Pipe Layer	FE	Feller Bunchers
L, LC	Long Crawler	NLD	Narrow Crawler Demolition
N, NC	Narrow Crawler	HR	High Reach Demolition
NL, NLC	Narrow Long Crawler	F, FX	Forestry Application
LM, LCM	Long Crawler Marsh	LD, LCD	Long Crawler Demolition
LR	Long Reach Boom & Arm	LC4	Long Crawler 4
LHDS	Long Crawler Heavy Duty Shanghai	LS	Long Crawler Shanghai
LHDC	Long Crawler Heavy Duty Changwon	NH	Narrow Heavy Duty
LRC4	Long Reach Crawler 4 (Boom & Arm)		

Supplementary PIN plate (EU countries only)

V	C	E	E	C	3	5	C	C	0	0	0	1	2	3	4	5
A			B				C		D							

V1076896

Figure 1

Example of 17 digit PIN number on PIN plate

- A. World Manufacturing Code
- B. Machine description
- C. Check letters
- D. Serial number

The supplementary plate contains information about machine mass in kg, engine net power in Kw, manufacturing year, machine serial number and a CE-mark.

Machine mass

The machine mass in kg on the supplementary PIN plate is based on:

- cab or canopy
- most used track type
- most usual bucket (without load)
- full fuel tank

For safety reasons, 103 % of the machine mass will be shown on the supplementary PIN plate.

2. Engine

The engine type designation, part and serial numbers are stamped on the top of valve cover.

3. Attachment quick coupler

This nameplate is attached on the outside of the bracket and indicates the part number and weight.

4. Bucket

This nameplate is attached on the top of the bucket and indicates the bucket model order number, serial number, bucket part number, rated capacity, weight, cutting width, tooth part number, and adapter part number.

5. Cab

The nameplate is attached on the inside of the cab and indicates the product number, serial number, model type, and weight.

Document Title: Volvo standard tightening torques	Function Group: 030	Information Type: Service Information	Date: 3/7/2026
Profile: EC350D Volvo			

Volvo standard tightening torques

Showing Selected Profile

Valid for serial numbers			
Model	Production site	Serial number start	Serial number stop
EC350D Volvo			

The tightening torques in the following tables apply to bolts and nuts with tensile strength. The tables should be used as a general instruction for tightening bolts and nuts without specified values. The charts contains values for course thread bolts and nuts.

Torque values should be increased with $\approx 10\%$, for flange bolts.

All standard torques for bolts are without surface treatment.

The standard torque for bolts lubricated with oil should be reduced with 20% of the given value.

Standard tightening torque charts

Bolt size Metric Coarse Threads	Tensile strength 8.8		Tensile strength 10.9	
	(Nm)	(lbf ft)	(Nm)	(lbf ft)
M5	6	4	8	6
M6	10	7	14	11
M8	25	18	35	26
M10	50	37	70	52
M12	87	64	122	90
M14	139	103	195	144
M16	213	157	299	220
M18	293	216	413	305
M20	416	307	585	432
M24	719	530	1010	745
M27	1060	782	1490	1100
M30	1140	840	2025	1493
M36	2500	1844	3600	2653

Bolt size Inch SAE Coarse Threads	Tensile strength 5		Tensile strength 8	
	(lbf ft)	(Nm)	(lbf ft)	(Nm)
1/4	10	13,6	14	19
5/16	21	28,5	29	39,3
3/8	37	50,2	52	70
7/16	59	80	84	114
1/2	90	122	128	174
9/16	130	176	184	250
5/8	180	244	254	345

3/4	320	434	451	612
7/8	515	700	728	988
1	775	1052	1091	1480
1 1/8	953	1290	1545	2100
1 1/4	1344	1823	2180	2960
1 3/8	1600	2170	2650	3600
1 1/2	2000	2714	3200	4340

Hydraulic connections, general

Before fitting pipe couplings, plugs and hoses:

- Make sure that the sealing surfaces are clean and free from pores or scratches.
- Check elastic seal rings for defects.
- Oil in threads, sealing surfaces and contact surfaces except for ORFS-connections (ORFS = O-Ring Face Seal).

Applying Torque correction factor by tool angle

Tool angle	Correction factor	
	ORFS	Stud-end
Allowable tolerance	±10%	- 0%, +10%
±0° ~ ±30°	5% over torque	
±30° ~ ±45°	20% over torque	
±45°	NOT allowable	

Tool access angle

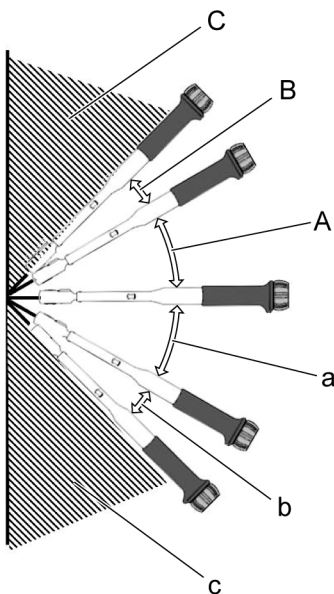

V1223202

Figure 1

Tool access angle

A: +0° ~ +30°

B: +30° ~ +45°

C: +45°

a: -0° ~ -30°

b: -30° ~ -45°

c: -45°

ORFS female swivel fitting

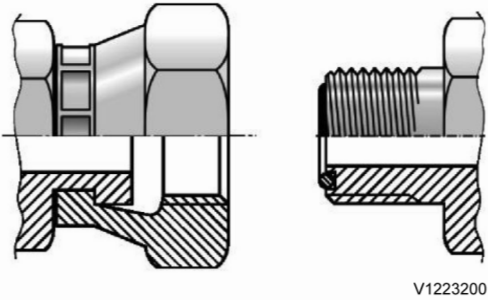

Figure 2

Thread s type	Assembl y position	Threads	Standard torque		±0° ~ ±30°		±30° ~ ±45°	
			(Nm)	(lbf ft)	(Nm)	(lbf ft)	(Nm)	(lbf ft)
UN- UNF	ORFS	UNF 9/16-18	29 ±3	21.4 ±2.2	30.5 ±3.1	22.1 ±2.2	36.5 ±3.7	26.9 ±2.7
		UN 11/16-16	44 ±4	32.5 ±3.0	46.2 ±4.6	34.1 ±3.4	55.4 ±5.5	40.9 ±4.1
		UN 13/16-16	63 ±6	46.5 ±4.4	66.2 ±6.6	48.8 ±4.9	79.4 ±7.9	58.6 ±5.9
		UNS 1-14	106 ±8	78.2 ±5.9	111.3 ±11.1	82.1 ±8.2	133.6 ±13.4	98.5 ±9.9
		UN 1 3/16-12	140 ±12	103.3 ±8.9	147.0 ±14.7	108.4 ±10.8	176.4 ±17.6	130.1 ±13.0
		UN 1 7/16-12	175 ±15	129.1 ±11.1	183.8 ±18.4	135.6 ±13.6	220.5 ±22.1	162.6 ±16.3
		UN 1 11/16-12	270 ±20	199.1 ±14.8	283.5 ±28.4	209.1 ±20.9	340.2 ±34.0	250.9 ±25.1
	Stud-end	UNF 7/16-20	21 +2.1	15.4 +1.5	22.1 +2.2	16.3 +1.6	26.5 +2.7	19.5 +2.0
		UNF 1/2-20	37 +3.7	27.3 +2.7	38.9 +3.9	28.7 +2.9	46.6 +4.7	34.4 +3.4
		UNF 9/16-18	47 +4.7	34.7 +3.5	49.4 +4.9	36.4 +3.6	59.2 +5.9	43.7 +4.4
		UNF 3/4-16	81 +8.1	59.7 +6.0	85.1 +8.5	62.8 +6.3	102.1 +10.2	75.3 +7.5
		UNF 7/8-14	141 +14.1	104.0 +10.4	148.1 +14.8	109.2 +10.9	177.7 +17.8	131.1 +13.1
		UN 1 1/16-12	189 +18.9	139.4 +13.9	198.5 +19.9	146.4 +14.6	238.1 +23.8	175.6 +17.6
		UN 1 5/16-12	284 +28.4	209.5 +21.0	298.2 +29.8	219.9 +22.0	357.8 +35.8	263.9 +26.4
UN 1 5/8-12	347 +34.7	255.9 +25.6	364.4 +36.4	268.8 +26.9	437.2 43.7	322.5 +32.3		

UN 1 7/8-12	425 +42.5	313.5 +31.4	446.3 +44.6	329.2 +32.9	535.5 +53.6	395.0 +39.5
----------------	-----------	-------------	-------------	-------------	-------------	-------------

G thread 30° cone female swivel fitting

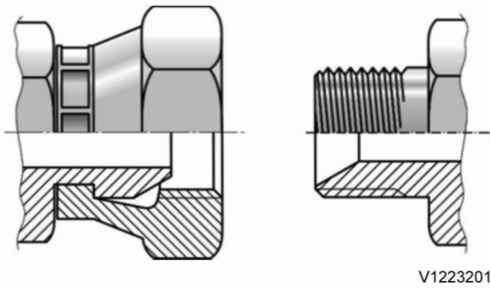

Figure 3

Thread s type	Assembl y position	Threads	Standard torque		±0° ~ ±30°		±30° ~ ±45°	
			(Nm)	(lbf ft)	(Nm)	(lbf ft)	(Nm)	(lbf ft)
PF	ORFS	G 1/4-19	25 ±2.5	18.4 ±1.8	26.3 ± 2.6	19.4 ±1.9	31.5 ±3.2	23.2 ±2.3
		G 3/8-19	49 ±4.9	36.1 ±3.6	51.5 ± 5.2	38.0 ±3.8	61.7 ±6.2	45.5 ±4.6
		G 1/2-14	59 ±5.9	43.5 ±4.4	62.0 ± 6.2	45.7 ±4.6	74.3 ±7.4	54.8 ±5.5
		G 3/4-11	119 ±11.9	87.8 ±8.8	125.0 ±12.5	92.2 ±9.2	149.9 ±15.0	110.6 ±11.1
		G 1-11	140 ±14	103.3 ±10.3	147.0 ±14.7	108.4 ±10.8	176.4 ±17.6	130.1 ±13.0
		G 1 1/4-11	173 ±17.3	127.6 ±12.8	181.7 ±18.2	134.0 ±13.4	218.0 ±21.8	160.8 ±16.1
		G 1 1/2-11	205 ±20.5	151.2 ±15.1	215.3 ±21.5	158.8 ±15.9	258.3 ±25.8	190.5 ±19.1
	Stud-end	G 1/8-19	22 +2.2	16.2 +1.6	23.1 +2.3	17.0 +1.7	27.7 +2.8	20.4 +2.0
		G 1/4-19	52 +5.2	38.4 +3.8	54.6 +5.5	40.3 +4.0	65.5 +6.6	48.3 +4.8
		G 3/8-19	85 +8.5	62.7 +6.3	89.3 +8.9	65.9 +6.6	107.1 +10.7	79.0 +7.9
		G 1/2-14	105 +10.5	77.4 +7.7	110.3 +11.0	81.4 +8.1	132.3 +13.2	97.6 +9.8
		G 3/4-11	210 +21	154.9 +15.5	220.5 +22.1	162.6 +16.3	264.6 +26.5	195.2 +19.5
		G 1-11	400 +40	295.0 +29.5	420.0 +42.0	309.8 +31.0	504.0 +50.4	371.7 +37.1
		G 1 1/4-11	525 +52.5	387.2 +38.7	551.3 +55.1	406.6 +40.7	661.5 +66.2	487.9 +48.8
G 1 1/2-11	630 +63.1	464.7 +46.5	661.5 +66.2	487.9 +48.8	793.8 +79.4	585.5 +58.6		

Document Title: Measurement conversion tables	Function Group: 030	Information Type: Service Information	Date: 3/7/2026
Profile: EC350D Volvo			

Measurement conversion tables

Showing Selected Profile

Valid for serial numbers			
Model	Production site	Serial number start	Serial number stop
EC350D Volvo			

Length

Unit	cm	m	km	in	ft	yd	mile
cm	1	0.01	0.00001	0.3937	0.03281	0.01094	0.000006
m	100	1	0.001	39.37	3.2808	1.0936	0.00062
km	100000	1000	1	39370.7	3280.8	1093.6	0.62137
in	2.54	0.0254	0.000025	1	0.08333	0.02777	0.000015
ft	30.48	0.3048	0.000304	12	1	0.3333	0.000189
yd	91.44	0.9144	0.000914	36	3	1	0.000568
mile	160930	1609.3	1.6093	63360	5280	1760	1

1 mm = 0.1 cm, 1 mm = 0.001 m

Area

Unit	cm ²	m ²	km ²	a	ft ²	yd ²	in ²
cm ²	1	0.0001	-	0.000001	0.001076	0.000012	0.155000
m ²	10000	1	0.000001	0.01	10.764	1.1958	1550.000
km ²	-	1000000	1	10000	1076400	1195800	-
a	0.01	100	0.0001	1	1076.4	119.58	-
ft ²	-	0.092903	-	0.000929	1	0.1111	144.000
yd ²	-	0.83613	-	0.008361	9	1	1296.00
in ²	6.4516	0.000645	-	-	0.006943	0.000771	1

1 ha = 100 a, 1 mile² = 259 ha = 2.59 km²

Volume

Unit	cm ³ = cc	m ³	Liter	in ³	ft ³	yd ³
cm ³ = m liter	1	0.000001	0.001	0.061024	0.000035	0.000001
m ³	1000000	1	1000	61024	35.315	1.30796
Liter	1000	0.001	1	61.024	0.035315	0.001308
in ³	16.387	0.000016	0.01638	1	0.000578	0.000021
ft ³	28316.8	0.028317	28.317	1728	1	0.03704
yd ³	764529.8	0.76453	764.53	46656	27	1

1 gal(US) = 3785.41 cm³ = 231 in³ = 0.83267 gal(UK)

Weight

Unit	g	kg	t	oz	lb
g	1	0.001	0.000001	0.03527	0.0022
kg	1000	1	0.001	35.273	2.20459
t	1000000	1000	1	35273	2204.59
oz	28.3495	0.02835	0.000028	1	0.0625
lb	453.592	0.45359	0.000454	16	1

1 tonne(metric) = 1.1023 ton(US) = 0.9842 ton(UK)

Pressure

Unit	kgf/cm ²	bar	Pa=N/m ²	kPa	lbf/in ²	lbf/ft ²
kgf/cm ²	1	0.98067	98066.5	98.0665	14.2233	2048.16
bar	1.01972	1	100000	100	14.5037	2088.6
Pa=N/m ²	0.00001	0.001	1	0.001	0.00015	0.02086
kPa	0.01020	0.01	1000	1	0.14504	20.886
lbf/in ²	0.07032	0.0689	6894.76	6.89476	1	144
lbf/ft ²	0.00047	0.00047	47.88028	0.04788	0.00694	1

1 kgf/cm² = 735.56 Torr(mmHg) = 0.96784 atm

Approximate conversions

SI	Conversion	Non-SI	Conversion	SI
Unit	Factor	Unit	Factor	Unit
Torque				
newton meter (N·m)	x 10.2	= kgf·cm	x 0.8664	= (lbf·in)
newton meter (N·m)	x 0.74	= lb·ft	x 1.36	= N·m
newton meter (N·m)	x 0.102	= kgf·m	x 7.22	= (lbf·ft)
Pressure (Pa = N/m²)				
kilopascal (kPa)	x 4.0	= in. H ₂ O	x 0.249	= kPa
kilopascal (kPa)	x 0.30	= in. Hg	x 3.38	= kPa
kilopascal (kPa)	x 0.145	= psi	x 6.89	= kPa
(bar)	x 14.5	= psi	x 0.069	= (bar)
(kgf/cm ²)	x 14.22	= psi	x 0.070	= (kgf/cm ²)
(newton/mm ²)	x 145.04	= psi	x 0.069	= (bar)
megapascal (MPa)	x 145	= psi	x 0.00689	= MPa
Power (W = J/s)				
kilowatt (kW)	x 1.36	= PS (cv)	x 0.736	= kW
kilowatt (kW)	x 1.34	= HP	x 0.746	= kW
kilowatt (kW)	x 0.948	= Btu/s	x 1.055	= kW
watt (W)	x 0.74	= ft·lb/s	x 1.36	= W

Note: () non-si unit

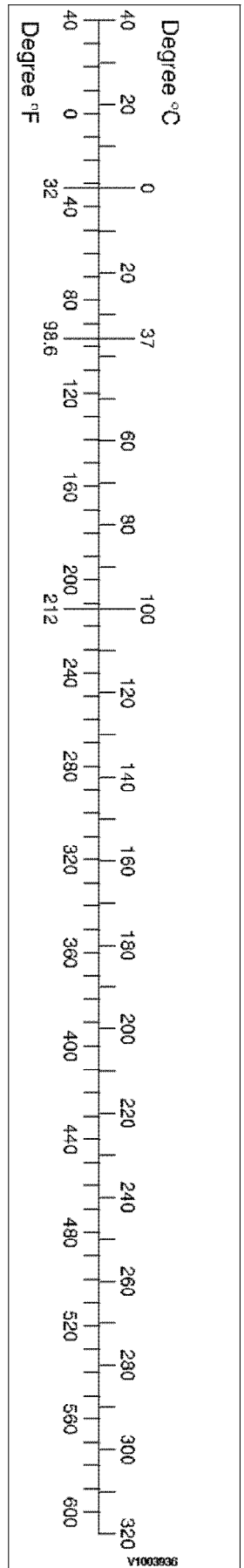

Approximate conversions

SI Unit	Conversion Factor	Non-SI Unit	Conversion Factor	SI Unit

Energy (J = N·m)				
kilojoule (kJ)	x 0.948	= Btu	x 1.055	= kJ
joule (J)	x 0.239	= calorie	x 4.19	= J
Velocity and Acceleration				
meter per sec ² (m/s ²)	x 3.28	= ft/s ²	x 0.305	= m/s ²
meter per sec (m/s)	x 3.28	= ft/s	x 0.305	= m/s
kilometer per hour (km/h)	x 0.62	= mph	x 1.61	= km/h
Horse power/torque				
BHP x 5252 rpm = TQ (lb-ft)			TQ x rpm 5252 = B.H.P.	
Temperature				
°C = (°F - 32) /1.8		°F = (°C x 1.8) + 32		
Flow Rate				
liter/min (dm ³ /min)	x 0.264	= US gal/min x 3.785		= liter/min

Note: () non-si unit

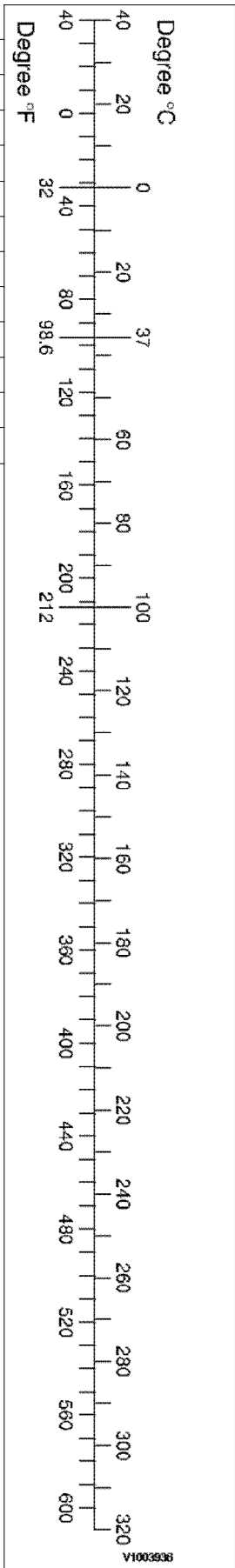

Document Title: Operation numbers for additional work	Function Group: 070	Information Type: Service Information	Date: 3/7/2026
Profile: Excavators (EXC)			

Operation numbers for additional work

Showing Selected Profile

These operations can be used to identify work that is not included in the time guide or described in the methods in the Service Manual. When these operations are used, a description of the work that has been performed must be provided.

Other work related to engine

Op. no. 070-210

This operation can be used when work has been done related to the engine and function group 2 when no applicable method description was available. When this operation is used, additional information is required:

- Description of work that has been done

Other work related to electrical system

Op. no. 070-310

This operation can be used when work has been done related to the electrical system and function group 3 when no applicable method description was available. When this operation is used, additional information is required:

- Description of work that has been done

Other work related to transmission, gearbox, travel motor, swing motor

Op. no. 070-410

This operation can be used when work has been done related to the transmission, gearbox, travel motor or swing motor and function group 4 when no applicable method description was available. When this operation is used, additional information is required:

- Description of work that has been done

Other work related to drive axle

Op. no. 070-470

This operation can be used when work has been done related to the drive axle and function group 46 when no applicable method description was available. When this operation is used, additional information is required:

- Description of required work that have been done

Other work related to brake system

Op. no. 070-510

This operation can be used when work has been done related to the brake system and function group 5 when no applicable

method description was available. When this operation is used, additional information is required:

- Description of work that has been done

Other work related to steering system

Op. no. 070-610

This operation can be used when work has been done related to the steering system and function group 6 when no applicable method description was available. When this operation is used, additional information is required:

- Description of work that has been done

Other work related to frame link, axle suspension

Op. no. 070-710

This operation can be used when work has been done related to the frame link, axle suspension and other parts related to function group 7 when no applicable method description was available. When this operation is used, additional information is required:

- Description of work that has been done

Other work related to cab, air conditioning

Op. no. 070-810

This operation can be used when work has been done related to the cab, air conditioning and other parts related to function group 8 when no applicable method description was available. When this operation is used, additional information is required:

- Description of work that has been done

Other work related to hydraulic system

Op. no. 070-910

This operation can be used when work has been done related to the hydraulic system and other parts related to function group 9 when no applicable method description was available. When this operation is used, additional information is required:

- Description of work that has been done

Document Title: Service positions	Function Group: 091	Information Type: Service Information	Date: 3/7/2026
Profile: EC350D Volvo			

Service positions

Showing Selected Profile

Valid for serial numbers			
Model	Production site	Serial number start	Serial number stop
EC350D Volvo			

Park the machine on a horizontal and firm surface.
The suitable position is indicated in the description for the various service jobs.
Before beginning any work on the machine.

- Turn off the engine and remove the ignition key.
- Depressurize all pressurized lines and pressure vessels carefully so that high pressure is released without risk.
- Allow the machine to cool down.

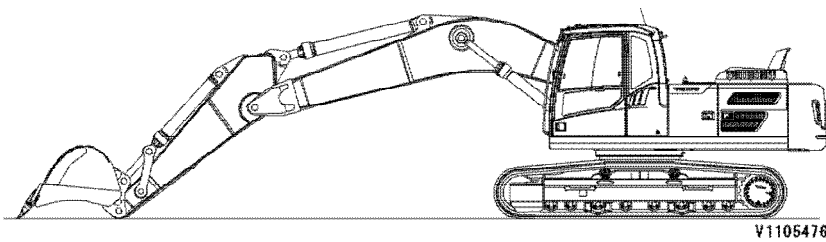

Figure 1
Service position A

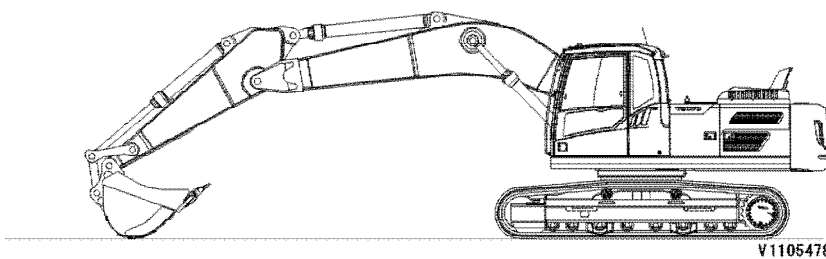

Figure 2
Service position B

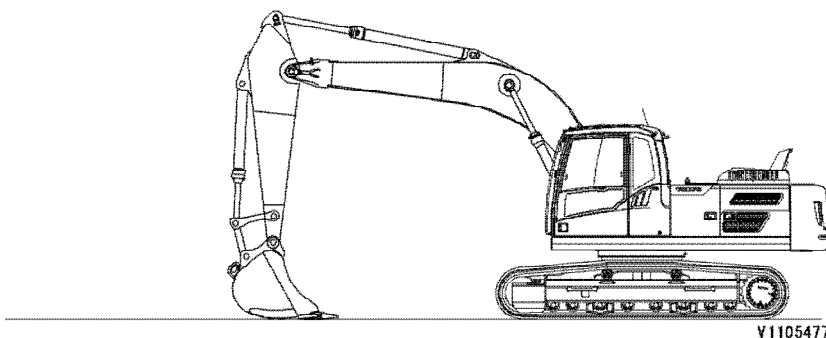

Figure 3
Service position C

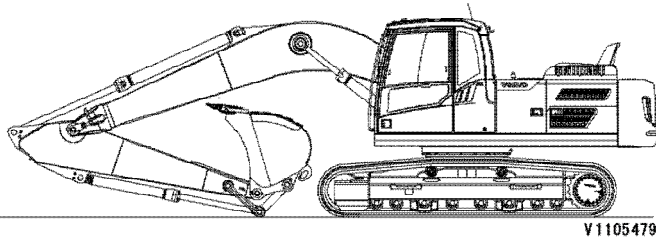

Figure 4
Service position D

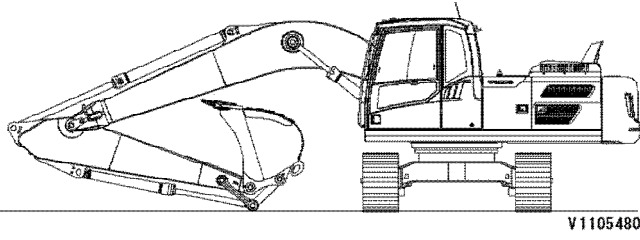

Figure 5
Service position E

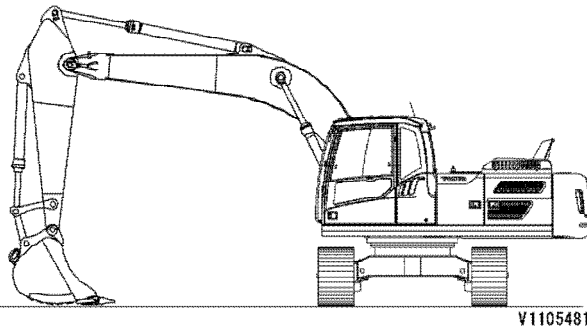

Figure 6
Service position F

Document Title: Welding on the machine	Function Group: 091	Information Type: Service Information	Date: 3/7/2026
Profile: EC350D Volvo			

Welding on the machine

Showing Selected Profile

Valid for serial numbers			
Model	Production site	Serial number start	Serial number stop
EC350D Volvo			

NOTICE

During electric welding on the machine or attachments connected to the machine, components such as bearings and electric units may be damaged if the ground cable is connected incorrectly.

The following actions should be taken before starting electric welding to eliminate these risks:

1. Turn off the electric power using the battery disconnecter.
2. Disconnect the batteries.
NOTE!
Both the plus and minus terminal.
3. Disconnect the following electronic units:
 - Vehicle electronic control unit (V-ECU)
 - Engine electronic control unit (E-ECU)
 - Instrument electronic control unit (I-ECU)
 - Electronic climate control unit (ECC)
 - Wiper control unit (CU3601)
4. Connect the welding unit's ground connection as close as possible to the welding point, and make sure that the current does not pass across a bearing.

If welding is necessary on the boom or dipper arm, the following basic rules should be followed:

1. Welding beads should be laid down in the longitudinal direction.
2. If possible, weld in the middle of the metal section and never closer than **80 mm** to an edge.
3. Do not weld near the welded connections of the cylinder mounting eyes. Minimum distance from eye's weld to weld for weld lug = **100 mm**.
4. Do not weld close to where a metal plate has been bent.

Document Title: Hydraulic cylinders, dieseling	Function Group: 091	Information Type: Service Information	Date: 3/7/2026
Profile: EC350D Volvo			

Hydraulic cylinders, dieseling

Showing Selected Profile

Valid for serial numbers			
Model	Production site	Serial number start	Serial number stop
EC350D Volvo			

If air enters the hydraulic cylinders during work on the hydraulic system, this can lead to spontaneous ignition, an effect known as dieseling. This occurs if a favourable mixture of air and hydraulic oil is compressed when the piston approaches its end position in the cylinder. A sufficiently high temperature can be reached for the mixture to spontaneously ignite.

NOTICE

The dieseling effect may result in burnt piston seals and bushings.

In order to prevent dieseling, the lines for the hydraulic cylinders must be bled after work is completed, as follows:

1. No load and keep the lowest engine rpm
2. Operate the piston slowly up to the middle of cylinder in order to remove air from inner chamber of cylinder. Repeat over 5 times.
After that, operate the piston up to the end of cylinder in order to remove residual air from cylinder, pipe and hose gradually. Repeat over 5 times.

NOTICE

If the cylinders are pressurized either through lifting of the machine or lifting of a load in the bucket, without first performing the mentioned bleeding movements, the seals will likely be damaged.

If a cylinder is to be pressure-tested after a repair, the piston rod should be run in and out a few times before increasing the pressure to testing pressure.

Document Title: Control units, changing	Function Group: 091	Information Type: Service Information	Date: 3/7/2026
Profile: EC350D Volvo			

Control units, changing

Showing Selected Profile

Valid for serial numbers			
Model	Production site	Serial number start	Serial number stop
EC350D Volvo			

Before changing electronic control unit Volvo CE product specialist should be consulted.

NOTE!

Before changing a control unit, customer parameters must be read out so that they can be programmed again.

Document Title: Recommended lubricants	Function Group: 160	Information Type: Service Information	Date: 3/7/2026
Profile: EC350D Volvo			

Recommended lubricants

Showing Selected Profile

Valid for serial numbers			
Model	Production site	Serial number start	Serial number stop
EC350D Volvo			

The Volvo lubricants have been specially developed to fulfil the demanding operating conditions, in which Volvo excavators are used in. The oils have been tested according to Volvo excavator specifications and therefore meet the high requirements for safety and quality. Other mineral oils can be used if they conform to our viscosity recommendations and meet our quality requirements. The approval of Volvo is required, if any other oil base quality (for example biologically degradable oil) is to be used.

NOTE!

If a high water or excessive contamination in the lubricants (e.g. engine oil, hydraulic oil, axle oil, etc.) is found by Volvo oil analysis, change the lubricants regardless of the change interval.

See service bulletins "Oil sampling" in function group 160.

System	Oil grade	Recommended viscosity at varying ambient temperature																				
Engine	Engine oil For detail, see page Engine oil .	<table border="1"> <tr> <td>°C</td> <td>-30</td> <td>-20</td> <td>-10</td> <td>0</td> <td>+10</td> <td>+20</td> <td>+30</td> <td>+40</td> <td>+50</td> </tr> <tr> <td>°F</td> <td>-22</td> <td>-4</td> <td>+14</td> <td>+32</td> <td>+50</td> <td>+68</td> <td>+86</td> <td>+104</td> <td>+122</td> </tr> </table>	°C	-30	-20	-10	0	+10	+20	+30	+40	+50	°F	-22	-4	+14	+32	+50	+68	+86	+104	+122
°C	-30	-20	-10	0	+10	+20	+30	+40	+50													
°F	-22	-4	+14	+32	+50	+68	+86	+104	+122													
Fuel	Diesel fuel For detail, see page Fuel .	<table border="1"> <tr> <td>°C</td> <td>-30</td> <td>-20</td> <td>-10</td> <td>0</td> <td>+10</td> <td>+20</td> <td>+30</td> <td>+40</td> <td>+50</td> </tr> <tr> <td>°F</td> <td>-22</td> <td>-4</td> <td>+14</td> <td>+32</td> <td>+50</td> <td>+68</td> <td>+86</td> <td>+104</td> <td>+122</td> </tr> </table> <p>NOTE! The fuel should at least meet the legal requirement, and national and international standards for marketed fuels, for example : EN590 (with nationally adapted temperature requirements), ASTM D975 No 1-D and No 2-D, JIS KK 2204.</p>	°C	-30	-20	-10	0	+10	+20	+30	+40	+50	°F	-22	-4	+14	+32	+50	+68	+86	+104	+122
°C	-30	-20	-10	0	+10	+20	+30	+40	+50													
°F	-22	-4	+14	+32	+50	+68	+86	+104	+122													
Cooling system	Volvo Coolant VCS-2 Ready Mixed For detail, see page Coolant .	Volvo Coolant VCS Ready Mixed should be used only. NOTE! The content of Volvo coolant must not be less than 40% of the total mixture.																				

*: Installed at factory

***: VDS-4 or VDS-4.5 approved oils only. Other oils can be used up to +30°C (86°F).

System	Oil grade	Recommended viscosity at varying ambient temperature																				
Hydraulic system	Hydraulic oil for severe cold area or if siberian option kit is installed	<table border="1"> <tr> <td>°C</td> <td>-30</td> <td>-20</td> <td>-10</td> <td>0</td> <td>+10</td> <td>+20</td> <td>+30</td> <td>+40</td> <td>+50</td> </tr> <tr> <td>°F</td> <td>-22</td> <td>-4</td> <td>+14</td> <td>+32</td> <td>+50</td> <td>+68</td> <td>+86</td> <td>+104</td> <td>+122</td> </tr> </table> <p>ISO VG15</p>	°C	-30	-20	-10	0	+10	+20	+30	+40	+50	°F	-22	-4	+14	+32	+50	+68	+86	+104	+122
	°C	-30	-20	-10	0	+10	+20	+30	+40	+50												
	°F	-22	-4	+14	+32	+50	+68	+86	+104	+122												
	Volvo Hydraulic Oil 98609 Extra 32 or Volvo Hydraulic Oil 98609 Extra 46 or Volvo Hydraulic Oil 98609 Extra 68 or Volvo Hydraulic Oil 98611 HO103 32 Volvo Hydraulic Oil 98611 HO103 46 Volvo Hydraulic Oil 98611 HO103 68	<table border="1"> <tr> <td>°C</td> <td>-30</td> <td>-20</td> <td>-10</td> <td>0</td> <td>+10</td> <td>+20</td> <td>+30</td> <td>+40</td> <td>+50</td> </tr> <tr> <td>°F</td> <td>-22</td> <td>-4</td> <td>+14</td> <td>+32</td> <td>+50</td> <td>+68</td> <td>+86</td> <td>+104</td> <td>+122</td> </tr> </table> <p>ISO VG32 HV ISO VG46 HV ISO VG68 HV</p>	°C	-30	-20	-10	0	+10	+20	+30	+40	+50	°F	-22	-4	+14	+32	+50	+68	+86	+104	+122
°C	-30	-20	-10	0	+10	+20	+30	+40	+50													
°F	-22	-4	+14	+32	+50	+68	+86	+104	+122													
Volvo Hydraulic Oil 98610 Biodegradable 46	<table border="1"> <tr> <td>°C</td> <td>-30</td> <td>-20</td> <td>-10</td> <td>0</td> <td>+10</td> <td>+20</td> <td>+30</td> <td>+40</td> <td>+50</td> </tr> <tr> <td>°F</td> <td>-22</td> <td>-4</td> <td>+14</td> <td>+32</td> <td>+50</td> <td>+68</td> <td>+86</td> <td>+104</td> <td>+122</td> </tr> </table> <p>Bio oil VG46</p> <p>NOTE! If the machine is filled with Volvo Biodegradable hydraulic oil this oil must also be used when filling and changing. The mineral oil content in bio oil should not exceed 2% when changing from mineral oil to bio oil. Contact a workshop authorised by Volvo.</p>	°C	-30	-20	-10	0	+10	+20	+30	+40	+50	°F	-22	-4	+14	+32	+50	+68	+86	+104	+122	
°C	-30	-20	-10	0	+10	+20	+30	+40	+50													
°F	-22	-4	+14	+32	+50	+68	+86	+104	+122													
Volvo Hydraulic Oil 98620 Ultra 32 or Volvo Hydraulic Oil 98620 Ultra 46 or Volvo Hydraulic Oil 98620 Ultra 68	<table border="1"> <tr> <td>°C</td> <td>-30</td> <td>-20</td> <td>-10</td> <td>0</td> <td>+10</td> <td>+20</td> <td>+30</td> <td>+40</td> <td>+50</td> </tr> <tr> <td>°F</td> <td>-22</td> <td>-4</td> <td>+14</td> <td>+32</td> <td>+50</td> <td>+68</td> <td>+86</td> <td>+104</td> <td>+122</td> </tr> </table> <p>ISO VG32 ISO VG46 ISO VG68</p>	°C	-30	-20	-10	0	+10	+20	+30	+40	+50	°F	-22	-4	+14	+32	+50	+68	+86	+104	+122	
°C	-30	-20	-10	0	+10	+20	+30	+40	+50													
°F	-22	-4	+14	+32	+50	+68	+86	+104	+122													

System	Oil grade	Recommended viscosity at varying ambient temperature																				
Track gearbox	Volvo Axle Oil 97321 80W-90 or	<table border="1"> <tr> <td>°C</td> <td>-30</td> <td>-20</td> <td>-10</td> <td>0</td> <td>+10</td> <td>+20</td> <td>+30</td> <td>+40</td> <td>+50</td> </tr> <tr> <td>°F</td> <td>-22</td> <td>-4</td> <td>+14</td> <td>+32</td> <td>+50</td> <td>+68</td> <td>+86</td> <td>+104</td> <td>+122</td> </tr> </table> <p>*SAE 90 SAE 140</p>	°C	-30	-20	-10	0	+10	+20	+30	+40	+50	°F	-22	-4	+14	+32	+50	+68	+86	+104	+122
°C	-30		-20	-10	0	+10	+20	+30	+40	+50												
°F	-22	-4	+14	+32	+50	+68	+86	+104	+122													
Swing gearbox	Volvo Axle Oil 97321 80W-140 or	<p>Or corresponding gearbox oil below.</p> <ul style="list-style-type: none"> ○ Mobil SHC630 ○ Volvo Synthetic Drum Eccentric Oil 																				
PTO gearbox (EC950 only)	Volvo Axle Oil 97317 75W-80 GO102 or Volvo Synthetic Axle Oil 97312 75W-90 or Volvo Axle Oil 97321 85W-90 Limited Slip																					
Swing ring gear (Bath and Ball)	Volvo Multipurpose Grease 97718 GR101	<table border="1"> <tr> <td>°C</td> <td>-30</td> <td>-20</td> <td>-10</td> <td>0</td> <td>+10</td> <td>+20</td> <td>+30</td> <td>+40</td> <td>+50</td> </tr> <tr> <td>°F</td> <td>-22</td> <td>-4</td> <td>+14</td> <td>+32</td> <td>+50</td> <td>+68</td> <td>+86</td> <td>+104</td> <td>+122</td> </tr> </table> <p>Multi purpose EP** grease NLGI 2</p> <p>Or corresponding grease on lithium base with EP** additives and consistency NLGI class 2.</p>	°C	-30	-20	-10	0	+10	+20	+30	+40	+50	°F	-22	-4	+14	+32	+50	+68	+86	+104	+122
°C	-30	-20	-10	0	+10	+20	+30	+40	+50													
°F	-22	-4	+14	+32	+50	+68	+86	+104	+122													
Pin and bushing	Volvo Extreme Grease 97765 GR103 or Volvo Multipurpose Grease 97718 GR101[T1] ⓘ For detail, see page Grease .	<table border="1"> <tr> <td>°C</td> <td>-30</td> <td>-20</td> <td>-10</td> <td>0</td> <td>+10</td> <td>+20</td> <td>+30</td> <td>+40</td> <td>+50</td> </tr> <tr> <td>°F</td> <td>-22</td> <td>-4</td> <td>+14</td> <td>+32</td> <td>+50</td> <td>+68</td> <td>+86</td> <td>+104</td> <td>+122</td> </tr> </table> <p>*ISO-L-XBCFB2</p> <p>Or corresponding grease on lithium base with EP** additives and consistency NLGI class 2.</p>	°C	-30	-20	-10	0	+10	+20	+30	+40	+50	°F	-22	-4	+14	+32	+50	+68	+86	+104	+122
°C	-30	-20	-10	0	+10	+20	+30	+40	+50													
°F	-22	-4	+14	+32	+50	+68	+86	+104	+122													
Air conditioner system	Refrigerant	HFC R134a																				

[T1] Volvo Multipurpose Grease 97718 GR101 is not recommended when the ambient temperature is above 40 °C.

*: Installed at factory
**: Extreme Pressure

Document Title: Grease	Function Group: 160	Information Type: Service Information	Date: 3/7/2026
Profile: EC350D Volvo			

Grease

Showing Selected Profile

Valid for serial numbers			
Model	Production site	Serial number start	Serial number stop
EC350D Volvo			

Recommended grease for all digging equipment greasing points

Manufacturer	Product name	
	Recommendations	Alternatives*
VOLVO	Volvo Extreme Grease 97765 GR103	Volvo Multipurpose Grease 97718 GR101
CALTEX	Molytex EP2	Multifak EP2
GULF	Gulflex Moly EP	Gulfcrown EP2
EXXONMOBIL	Beacon EP2 Moly	Beacon EP2
SHELL	Retinax HDX2 / Alvania HDX2	Retinax EP2 / Alvania EP2
TOTAL	Multis MS2	Multis EP2
CASTROL	Pyro LM	Pyroplex Red

* Alternatives are not recommended when the ambient temperature is above 40 °C.

Mixability of types of grease with different additives

	Mixability of types of grease with additives					
	Lithium	Calcium	Lithium complex	Calcium complex	Aluminium complex	Clay
Lithium	√	√	√			
Calcium	√	√	√			√
Lithium complex	√	√	√	√		
Calcium complex			√	√		
Aluminium complex			√		√	
Clay		√			√	√

√ : Acceptable

Document Title: Hydraulic oil	Function Group: 160	Information Type: Service Information	Date: 3/7/2026
Profile: EC350D Volvo			

[Go back to Index Page](#)

Hydraulic oil

Showing Selected Profile

Valid for serial numbers			
Model	Production site	Serial number start	Serial number stop
EC350D Volvo			

Only use Volvo genuine hydraulic oil approved by Volvo Construction Equipment. Do not mix different brands of hydraulic oil as this can lead to damage in the hydraulic system.

When changing different type of hydraulic oil, the oil must be drained as much as possible and it is required to flush the hydraulic system. For the drain points and changing method, please contact the workshop authorized by Volvo Construction Equipment.

For the hydraulic oil specification, see page [Recommended lubricants](#).

	Ambient temperature												
	°C	-50	-40	-30	-20	-10	0	+10	+20	+30	+40	+50	+60
	°F	-58	-40	-22	-4	+14	+32	+50	+68	+86	+104	+122	+140
General oil grade			(B)		(A)			(C)					
				(B)		(A)			(C)				
					(B)		(A)						
Severe cold areas GS Hydro HDZ 15			(B)	(A)			(C)						

(A) : Ambient temperature recommended for general use of hydraulic system and components.

(B) : Ambient temperature guide for machine operation from a hydraulic oil viewpoint only, it does not guarantee the completion machine for other conditions like engine starting performance. In this range a warming-up period is needed to obtain proper performance.

(C) : Ambient temperature range to operate machine under special conditions, not a recommendation for general use conditions.

Additional information for severe cold areas

Severe cold condition of ambient temperature is between -45°C and 0°C.

Normal temperature of hydraulic oil is between -33°C and 55°C.

- Type : Anti-wear type hydraulic oil
- Viscosity characteristic

NOTE!

It is minimum theoretical recommendation without the guarantee of machine condition.

Document Title: Hydraulic oil	Function Group: 160	Information Type: Service Information	Date: 3/7/2026
Profile: EC350D Volvo			

[Go back to Index Page](#)

Hydraulic oil

Showing Selected Profile

Valid for serial numbers			
Model	Production site	Serial number start	Serial number stop
EC350D Volvo			

Only use Volvo genuine hydraulic oil approved by Volvo Construction Equipment. Do not mix different brands of hydraulic oil as this can lead to damage in the hydraulic system.

For the hydraulic oil specification, see page [Recommended lubricants](#).

	Ambient temperature											
	°C	-40	-30	-20	-10	0	+10	+20	+30	+40	+50	+60
	°F	-40	-22	-4	+14	+32	+50	+68	+86	+104	+122	+140
Oil grade		(B)		(A)			(C)					
			(B)		(A)			(C)				
			(B)		(A)							

(A) : Ambient temperature recommended for general use of hydraulic system and components.

(B) : Ambient temperature guide for machine operation from a hydraulic oil viewpoint only, it does not guarantee the completion machine for other conditions like engine starting performance. In this range a warming-up period is needed to obtain proper performance.

(C) : Ambient temperature range to operate machine under special conditions, not a recommendation for general use conditions.

Additional recommendation for severe cold areas

A field solution for severe cold condition of ambient temperature between -40°C and +20°C.

- Type : Anti-wear type hydraulic oil
- Viscosity characteristic

Viscosity index : More than 130

Kinematic Viscosity : Less than 5,000cSt at -40°C, More than 5.6cSt at +90°C

NOTE!

This value is approximately equivalent to ISO Viscosity grade #22.

NOTE!

It is minimum theoretical recommendation without the guarantee of machine condition.

NOTE!

If the machine is filled with biodegradable Volvo hydraulic oil, it is recommended to take regular oil samples. See service bulletin "Recommendations for Oil Sampling Intervals" in function group 160.

Document Title: Lubricants and filling capacities	Function Group: 160	Information Type: Service Information	Date: 3/7/2026
Profile: EC350D Volvo			

Change capacities

Showing Selected Profile

Valid for serial numbers			
Model	Production site	Serial number start	Serial number stop
EC350D Volvo			

Oils and other liquids	Change capacities
Engine oil, including filter	32 litres (8.5 US gal.)
Coolant	41 litres (10.8 US gal.)
Hydraulic tank	215 litres (56.8 US gal.)
Hydraulic system, total	465 litres (122.9 US gal.)
Swing gearbox	6.1 litres (1.6 US gal.)
Track gearbox (each)	6.8 litres (1.8 US gal.)
Fuel tank	580 litres (153.2 US gal.)
Swing ring gear	36 litres (9.5 US gal.) 32.4 kg (71.4 lb)
Oil bath air cleaner	5.5 litres (1.45 US gal.)

Document Title: Engine oil	Function Group: 160	Information Type: Service Information	Date: 3/7/2026
Profile: EC350D Volvo			

Engine oil

Showing Selected Profile

Valid for serial numbers			
Model	Production site	Serial number start	Serial number stop
EC350D Volvo			

Follow recommended change intervals according to the oil's grade and sulphur content in the fuel.

Oil grade	Sulphur content in the fuel, ppm (10000 ppm = 1%)		
	< 3000	3000 - 5000	5000 - 10000
	Oil change interval		
Volvo Engine Oil VDS-4.5 10W-30 or Volvo Engine Oil VDS-4.5 15W-40 or Other approved VDS-4.5 oil	500 hours	250 hours	125 hours
Other approved VDS-4 oil			
Volvo Engine Oil VDS-3 10W-40 or Volvo Engine Oil VDS-3 15W-40 or Other approved VDS-3 oil			
ACEA: E7 or E9	250 hours	125 hours	75 hours
API: CH-4 or CI-4 or CJ-4 or CK-4			

- ACEA: European Automobile Manufacturers Association
- API: American Petroleum Institute

Document Title: Fuel	Function Group: 160	Information Type: Service Information	Date: 3/7/2026
Profile: EC350D Volvo			

Fuel

Showing Selected Profile

Valid for serial numbers			
Model	Production site	Serial number start	Serial number stop
EC350D Volvo			

Fuel quality requirements

The fuel should at least meet the legal requirements, national and international standards for marketed fuels, for example: EN590 (with nationally adapted temperature requirements), ASTM D 975 No. 1D and 2D, JIS KK 2204. Fuel specification varies according to the working temperature. Please contact authorized Volvo dealer.

Sulphur content

- **With Tier III engine, D8K**
Fill with normal fuel below 0.05 percent (500 ppm) sulphur content by weight. Otherwise, engine may be damaged in some cases. In that case, Volvo cannot cover it by the warranty.
- **With Tier II engine, D8F**
Fill with normal fuel below 1 percent (10000 ppm) sulphur content by weight. Otherwise, engine may be damaged in some cases. In that case, Volvo cannot cover it by the warranty.

NOTE!

In compliance with China's nationwide standard GB 252-2011, the sulphur content in the diesel fuel must not exceed 0.035 percent (350 ppm) by weight until new China's nationwide standard is announced.

Bio-diesel fuel

Vegetable oils and / or esters, also called "bio-diesel", (e.g. rape-seed methyl ester RME fuel), which are offered on certain markets both as pure products and as mixed into the diesel fuel.

Volvo Construction Equipment accepts a maximum intermix of 7% bio-diesel fuel in the diesel fuel, ready mixed from the oil companies. A higher intermix than 7% of bio-diesel fuel may cause:

- Increased emission by nitrogen oxide, (thereby not meeting legal requirements)
- Shorter service life of engine and injection system
- Increased fuel consumption
- Altered engine output
- Shortening the engine oil change interval to a half
- Shortened service life of rubber materials in the fuel system
- Less good cold handling properties of the fuel
- Limit storage time for the fuel, which may cause clogging up of the fuel system if the machine is laid up for longer periods

Warranty condition

The warranty does not cover damage caused by an intermix of more than 7% of bio-diesel fuel.

Document Title: Alternative fuels	Function Group: 160	Information Type: Service Information	Date: 3/7/2026
Profile: EC350D Volvo			

Alternative fuels

Showing Selected Profile

Valid for serial numbers			
Model	Production site	Serial number start	Serial number stop
EC350D Volvo			

This statement is only valid for Volvo branded engines.

Hydro-treated vegetable oil (HVO) and fatty acid methyl ester (FAME) biodiesel are both made from renewable raw materials such as vegetable oils and animal fats, but they are chemically processed in different ways.

Hydro-treated vegetable oil (HVO)

HVO is created using a chemical process called hydro-treating. Hydro-treating creates an oxygen-free hydrocarbon product that is very similar to distillate diesel fuel and is well suited for use in diesel engines. HVO fuels complying with the CEN diesel fuel standard EN 590:2013 or with the European Fuel Quality Directive 98/70/EC are approved for use in all Volvo Construction Equipment diesel engines with no changes to maintenance intervals. Paraffinic diesel fuels complying with the CEN standard EN 15940 may be used in all machines operating outside the European Union and for EU-certified engines up to the emission level Stage IV. These fuels may also be used for the EU-certified D11, D13 and D16 engines meeting the emission level Stage V.

Biodiesel

Biodiesel is a product made from renewable resources such as vegetable oils or animal fat. Biodiesel that has been chemically processed into fatty acid methyl ester (FAME) can be blended with distillate diesel fuel and used in some diesel engines. Unblended biodiesel is referred to as B100 because it is 100% biodiesel.

Rapeseed methyl ester (RME) is the most common type of FAME used in Europe. Soy methyl ester (SME) and sunflower oil methyl ester (SOME) are the most common types of FAME used in the US.

Although use of FAME biodiesel is now a legal requirement in some markets, it is not as suitable for use in diesel engines as conventional diesel fuel or HVO (hydro-treated vegetable oil).

Biodiesel fuel requirements

The FAME biodiesel blends specified in the table below are approved for use if:

- The biodiesel is pre-blended by the fuel supplier
- The biodiesel used in the blend conforms to EN14214 or ASTM D6751
- The distillate fuel used in the blend meets fuel sulphur requirements
- The distillate fuel used in the blend conforms to EN590 or ASTM D975
- B1-B5 biodiesel blends conform to EN590 or ASTM D975
- B6-B7 biodiesel blends conform to EN590 or ASTM D7467
- B8-B20 biodiesel blends conform to EN16709(B20) or ASTM D7467

Engine emission designation	Engine size	Acceptable blend
EU Stage II / US Tier 2 * EU Stage IIIA / US Tier 3 * EU Stage IIIB / US Tier 4 interim EU Stage IV / US Tier 4 final EU Stage V	Below D4 / 4 litres	Up to B7
EU Stage II / US Tier 2 * EU Stage IIIA / US Tier 3 * EU Stage IIIB / US Tier 4 interim EU Stage IV / US Tier 4 final	D4–D8	Up to B7
EU Stage II / US Tier 2 * EU Stage IIIA / US Tier 3 *	D9–D16	Up to B20

Sample manual. Download All 2405 pages at:

<https://www.arepairmanual.com/downloads/ec350d-volvo-excavator-service-manual/>