

Document Title: Cylinder data	Function Group: 030	Information Type: Service Information	Date: 3/7/2026
Profile:			

Cylinder data

Cylinder	Boom	Dipper arm	Bucket
Cylinder bore	150 mm	170 mm	150 mm
Piston rod diameter	105 mm	125 mm	105 mm
Stroke	1 360 mm	1 560 mm	1 280 mm
Piston force, out	548 kN	704 kN	548 kN
Piston force, out in HLD	619 kN	794 kN	619 kN

Cylinder times

The cylinder times are measured at a temperature of 30°C outdoors, with the hydraulic oil warmed up to 55°C.

Mode	Boom cylinder (sec.) *)	Dipper arm cylinder (sec.)	Bucket cylinder (sec.)
HLD -	2.3	4.0	1.9
HLD +	7.4	6.6	3.3
Standard -	2.4	2.4	1.9
Standard +	4.4	4.1	3.3
Float HLD -	2.7	-	-
Float Standard -	2.7	-	-

*) Boom cylinder c - c = 1 150 mm. Stroke = 890 mm

Document Title: Tightening torque, banjo fittings	Function Group: 030	Information Type: Service Information	Date: 3/7/2026
Profile:			

Tightening torque, banjo fittings

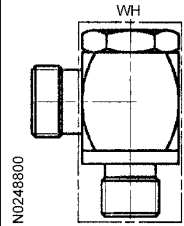
	Thread (inch/mm)	Pressure class	Pipe o.d. (mm)	Width across flats (mm)	Torque (Nm) *)
14 026 430	G 1/4	Low	8	19	50
14 026 431	G 1/4	Low	10	19	50
14 026 152	G 1/2	Low	15	30	130
14 214 142	G 1/4	High	8	19	50
14 211 073	G 3/4	High	20	36	250
14 213 319	M 12x1.5	Low	8	19	50
14 213 320	M 14x1.5	Low	10	19	60
14 213 321	M 16x1.5	Low	12	24	90
14 026 454	M 18x1.5	Low	15	27	110
14 215 499	M 22x1.5	Low	18	30	150
Low = 31.5 MPa High = 40 MPa *) Prerequisites: Oiled thread and contact surface.					

Document Title: Tightening torque, bolts and nuts	Function Group: 030	Information Type: Service Information	Date: 3/7/2026
Profile:			

Tightening torque, bolts and nuts

	Flange bolt					Hex socket and hexagonal bolts						Blind rivet nut
	Width across flats Torque (Nm)					Width across flats Torque (Nm)						Torque (Nm)
Thread		8.8 Fe/Zn-Fe Dry	8.8 Fe/Zn-Fe Lubricated	10.9 Phosphatized	10.9 Phosphatized Lubricated	Hex socket	Hex socket	8.8 Bright-galvanized & Fe/Zn-Fe-dry Untreated-lubr. hot-dip-galvanized-lubr.	8.8 Bright-galvanized & Fe/Zn-Fe Lubricated	10.9 Untreated Lubricated	12.9 Untreated Lubricated	
M5	8	7	6			8	4	6	5			6
M6	10	12	10			10	5	10	9		20	10
M8	12	28	24			13	6	25	22		40	24
M10	14	56	48	70	60	16	8	50	44	60	80	48
M12	17	100	85	125	105	18	10	85	75	105	140	82
M14	18	160	140	200	175	21	12	135	125	175	220	
M16	21	250	220	320	275	24	14	205	190	275	340	
M20						30	17	370	350	540	650	
M24						36	19	700	640	900	1120	
M27						41	-	1100	940	1350	1620	
M30						46	22	1500	1280	1840	2210	
M36						55		2500	2200	3210	3850	
1/4						7/16	3/16	12	10	15	20	
5/16						1/2	1/4	25	21	30	40	
3/8						9/16	5/16	45	38	55	70	
7/16						5/8		65	55	90		
1/2						3/4	3/8	100	85	130	170	
9/16						13/16		145	123	190		

The pretensioning force achieved at a given tightening torque depends on the coefficient of friction of the bolted joint.

The coefficient of friction in turn depends on the surface texture under the bolt head, surface treatment, lubrication etc. The values are calculated assuming a coefficient of friction of 0.2 for a dry chromated flange bolt and 0.15 for a lubricated chromated flange bolt.

Hex socket bolts and traditional hexagonal bolts have a 10% lower torque owing to the smaller diameter of the bolt head.

Lubricated untreated and lubricated hot-dip-galvanized bolts of class 8.8 have approximately the same coefficient of friction as dry chromated 8.8 bolts and are listed in the same column.

NOTE!

When using a Nordloc washer, increase the torque by 20%.

NOTE!

Tighten bolts with liquid or micro-encapsulated thread lock or thread seal to the same torque as lubricated bolts of the same type.

Document Title: Tightening torque, DKO connections	Function Group: 030	Information Type: Service Information	Date: 3/7/2026
Profile:			

Tightening torque, DKO connections

Tighten DKO connections with an open-ended torque wrench. Each pipe size and pressure class has its own fixed tool.

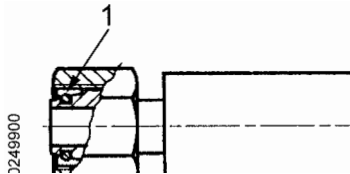
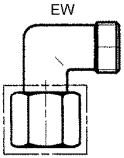
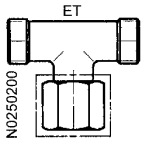

Figure 1
O-ring

1. O-ring

 EW N0250100	 ET N0250200	Thread (mm)	Pressure class *)	Pipe outside diameter (mm)	Width across flats (mm)	Torque (Nm) **)
14 012 391	14 012 387	M14x1.5	L	8	17	30
14 012 393	14 012 388	M16x1.5	L	10	19	40
14 012 395	14 012 389	M22x1.5	L	15	27	75
14 012 397	14 043 552	M30x2.0	L	22	36	110
14 012 392	–	M16x1.5	S	8	19	40
14 310 009	–	M18x1.5	S	10	22	50
14 214 854	14 341 817	M24x1.5	S	16	30	80
14 012 396	14 211 064	M30x2.0	S	20	36	120
14 012 398	14 024 423	M36x2.0	S	25	46	170
–	–	M36x2.0	S	25	41	170
14 012 399	14 012 390	M42x2.0	S	30	50	250
14 016 972	–	M52x2.0	S	38	60	350

*) L = Low, S = High

**) For sizes 8-L, 10-L and 15-L, old hoses of type PARKER series 43 should have a torque of 15, 25 and 45.

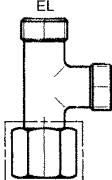
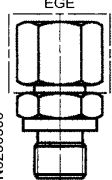
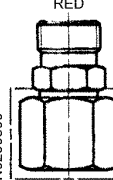
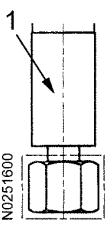
 N0250300	 N0250500	 N0250800	 1. Hydraulic hose	Thread (mm)	Pressure class **)	Pipe outside diameter (mm)	Width across flats (mm)	Torque (Nm) ***)
14 012 383	*)	*)	*)	M14x1.5	L	8	17	30
14 052 740	*)	*)	*)	M16x1.5	L	10	19	40
14 012 384	*)	*)	*)	M22x1.5	L	15	27	75
14 043 547	–	*)	*)	M30x2.0	L	22	36	110
14 215 487	–	–	*)	M16x1.5	S	8	19	40
–	–	*)	–	M18x1.5	S	10	22	50
14 341 816	–	–	–	M24x1.5	S	16	30	80
14 211 065	*)	*)	*)	M30x2.0	S	20	36	120
14 012 385	*)	*)	–	M36x2.0	S	25	46	170
–	–	–	*)	M36x2.0	S	25	41	170
14 012 386	*)	*)	*)	M42x2.0	S	30	50	250
14 016 554	*)	*)	*)	M52x2.0	S	38	60	350

*) There are several different art. nos. for each nominal pipe size.

**) L = Low, S = High

***) For sizes 8-L, 10-L and 15-L, old hoses of type PARKER series 43 should have a torque of 15, 25 and 45.

Document Title: Tightening torque, general	Function Group: 030	Information Type: Service Information	Date: 3/7/2026
Profile:			

Tightening torque, general

Before installing pipe fittings, plugs and hoses:

- Make sure that the sealing surfaces are clean, free of pores and scratches and have the prescribed surface texture.
- Check elastic sealing rings for defects.
- Oil threads, tapers, sealing and contact surfaces.

Tightening torque in Nm							
Nm	5 – 10	11 – 50	51 – 100	101 – 200	201 – 400	401 – 1 000	1 001 –
Tolerance	±1.5	±4	±10	±20	±40	±80	±100

Document Title: Tightening torque, hose clamps	Function Group: 030	Information Type: Service Information	Date: 3/7/2026
Profile:			

Tightening torque, hose clamps

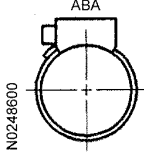
	For outside diameter (mm)	Width across flats (mm)	Torque (Nm)
943 469	10 – 13	7	3.0
943 470	(13) – 16	7	3.0
–	(16) – 19	7	4.5
943 472	(19) – 23	7	4.5
943 473	(23) – 27	7	4.5
943 474	(27) – 30	7	4.5
943 475	(30) – 36	7	4.5
943 476	(36) – 43	7	5.5
943 477	(43) – 49	7	5.5
943 478	(49) – 54	7	5.5
943 479	(54) – 64	7	5.5
943 480	(64) – 73	7	5.5
943 481	(73) – 83	7	5.5
943 482	(83) – 93	7	5.5
943 483	(93) – 110	7	5.5
943 484	(110) – 136	7	5.5
943 485	(136) – 163	7	5.5
14 016 541	(163) – 180	7	5.5
14 042 985	(205) – 231	7	5.5
PA – RI			
14 261 827	(39) – 45	5	5
14 261 828	(49) – 55	5	5
14 261 829	(61) – 67	5	5
14 261 830	(73) – 79	5	5

Document Title: Tightening torque, pipe end plugs	Function Group: 030	Information Type: Service Information	Date: 3/7/2026
Profile:			

Tightening torque, pipe end plugs

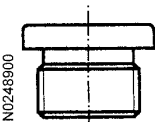
 N0248900	Thread (inch/mm)	Pressure class (bar) *	Hex socket drive (mm)	Torque (Nm) **)
14 023 406	G 1/8	400	5	15
14 023 407	G 1/4	400	6	33
14 023 408	G 3/8	400	8	70
14 023 409	G 1/2	400	10	90
14 023 410	G 3/4	400	12	150
14 023 411	G 1	400	17	250
14 215 723	G 1 1/4	400	22	600
14 215 724	G 1 1/2	400	24	800
14 023 412	G 1 1/4	250	22	500
14 023 413	G 1 1/2	250	24	500
14 024 363	M 10x1.0	400	5	13
14 211 624	M 12x1.5	400	6	30
14 211 623	M 14x1.5	400	6	40
14 211 625	M 16x1.5	400	8	60
14 024 814	M 18x1.5	400	8	70
14 024 233	M 22x1.5	400	10	100
14 340 607	M 26x1.5	400	12	120
14 266 484	M 27x2.0	400	12	150
14 267 223	M 33x2.0	400	17	250
14 212 167	M 42x2.0	250	22	400
*) 250 bar = 25 MPa, 400 bar = 40 MPa. **) Prerequisites: Oiled thread and contact surface.				

Document Title: Tightening torque, pipe nuts	Function Group: 030	Information Type: Service Information	Date: 3/7/2026
Profile:			

Tightening torque, pipe nuts

Thread (mm)	Pressure class	Pipe outside diameter (mm)	Width across flats	Torque (Nm)
M12x1.5	Low	6	14	25
M14x1.5	Low	8	17	35
M16x1.5	Low	10	19	45
M18x1.5	Low	12	22	75
M22x1.5	Low	15	27	110
M26x1.5	Low	18	32	180
M30x2.0	Low	22	36	280
M36x2.0	Low	28	41	300
M45x2.0	Low	35	50	450
M52x2.0	Low	42	60	680
M14x1.5	High	6	17	45
M16x1.5	High	8	19	65
M18x1.5	High	10	22	80
M20x1.5	High	12	24	100
M22x1.5	High	14	27	140
M24x1.5	High	16	30	160
M30x2.0	High	20	36	350
M36x2.0	High	25	46	450
M42x2.0	High	30	50	650
M52x2.0	High	38	60	800

Document Title: Tightening torque, valve connections	Function Group: 030	Information Type: Service Information	Date: 3/7/2026
Profile:			

Tightening torque, valve connections

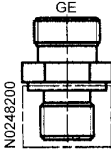
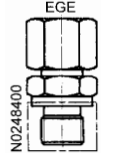
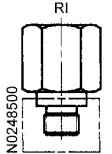
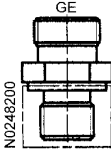
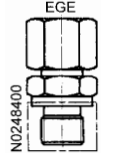
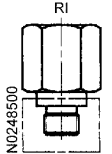
			Thread (inch/mm)	Pressure class	Pipe outside diameter (mm)	Width across flats (mm)	Torque (Nm) **)
							
14 012 413	14 023 056	*)	G 1/4	Low	8	19	40
14 012 418	14 023 611	*)	G 1/4	Low	10	19	40
14 012 423	14 012 381	*)	G 1/2	Low	15	27	90
14 012 431	–	*)	G 3/4	Low	22	32	180
14 215 486	–	–	G 1/4	High	8	19	54
14 012 428	14 211 062	*)	G 3/4	High	20	32	180
14 012 432	14 012 382	*)	G 1	High	25	41	315
14 012 433	14 042 775	*)	G 1 1/4	High	30	50	450
14 012 436	14 023 190	*)	G 1 1/2	High	38	55	540
14 025 136	–	–	M 12x1.5	Low	8	17	30
14 100 430	14 341 573	–	M 14x1.5	Low	10	19	45
14 213 266	14 340 537	–	M 16x1.5	Low	12	22	54
14 012 424	14 263 962	–	M 18x1.5	Low	15	24	80
14 012 430	–	–	M 26x1.5	Low	22	32	180
14 012 416	–	–	M 14x1.5	High	8	19	54
14 211 561	–	–	M 16x1.5	High	10	22	72
14 266 715	14 266 716	–	M 22x1.5	High	16	27	135
14 211 250	14 211 244	–	M 27x2.0	High	20	32	180
14 025 324	–	–	M 33x2.0	High	25	41	315
14 016 814	14 016 813	–	M 42x2.0	High	30	50	450
–	–	–	M 48x2.0	High	38	55	540

*) There are several different art. nos. and across-flats widths for each nominal pipe size.

**) Prerequisites: Oiled thread and contact surface.

Document Title: E-tool, NET 00004 Distance template	Function Group: 080	Information Type: Service Information	Date: 3/7/2026
Profile:			

E-tool, NET 00004 Distance template

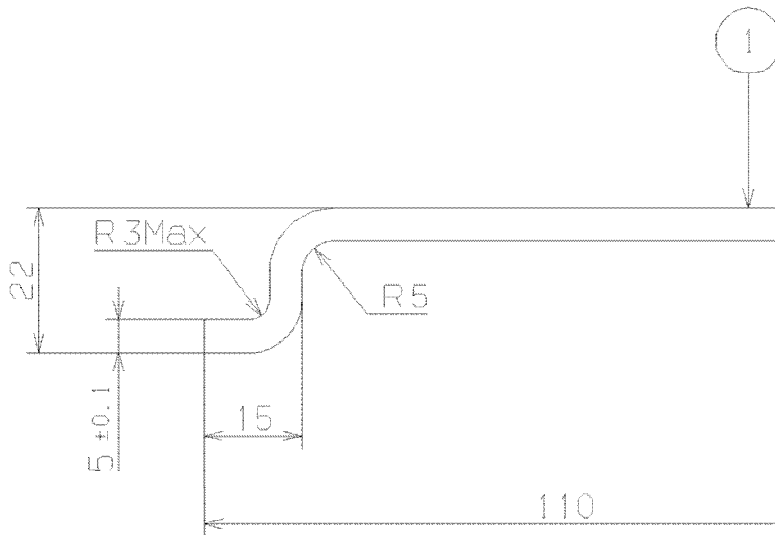
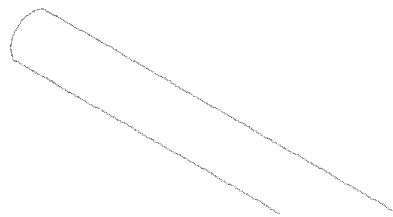
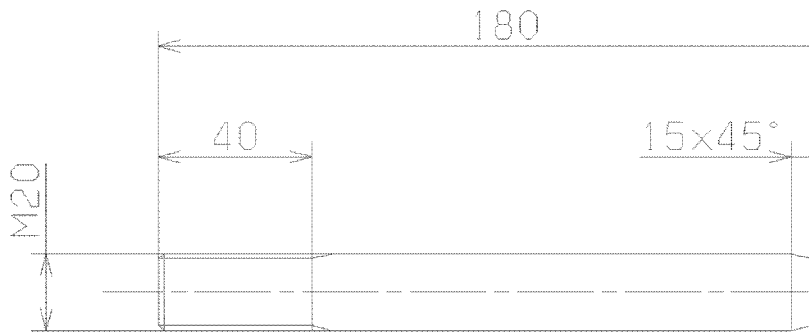

Figure 1
Distance template

Item	Quantity	Name
1	1	Square 5, Steel 1914-04

Document Title: E-tool, NET 00005 Guide pin	Function Group: 080	Information Type: Service Information	Date: 3/7/2026
Profile:			

E-tool, NET 00005 Guide pin



3700

Figure 1
Guide pin

Item	Quantity	Name
1	2	Round bar Ø20, Steel 2172-06

Document Title: E-tool, NET 00007 Assembly fixture	Function Group: 080	Information Type: Service Information	Date: 3/7/2026
Profile:			

E-tool, NET 00007 Assembly fixture

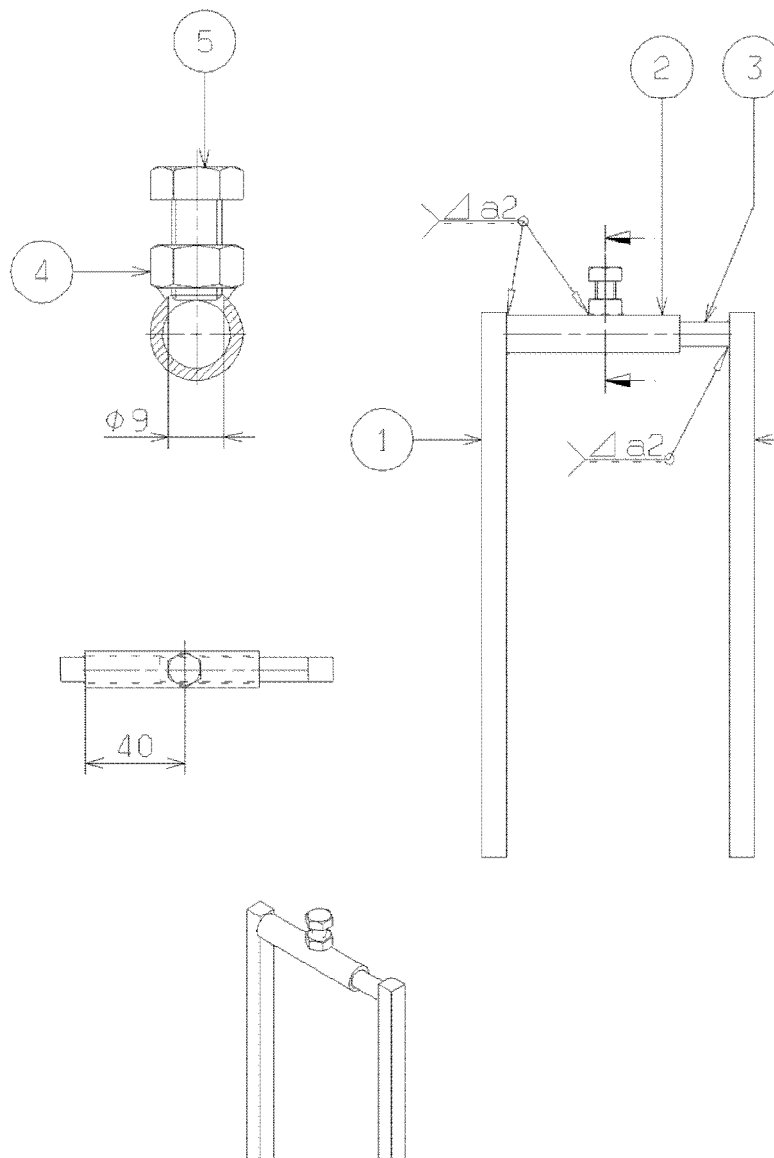

Figure 1
Assembly fixture

Item	Quantity	Name
1	2	Square 10x220, Steel 1312-00
2	1	Pipe Ø15x2x70, Steel DIN 2445
3	1	Round bar Ø10x60, Steel 1312-00
4	1	Nut M8
5	1	Bolt M6S 8x16

Document Title: E-tool, NET 00008 Lifting lug for radiator	Function Group: 080	Information Type: Service Information	Date: 3/7/2026
Profile:			

E-tool, NET 00008 Lifting lug for radiator

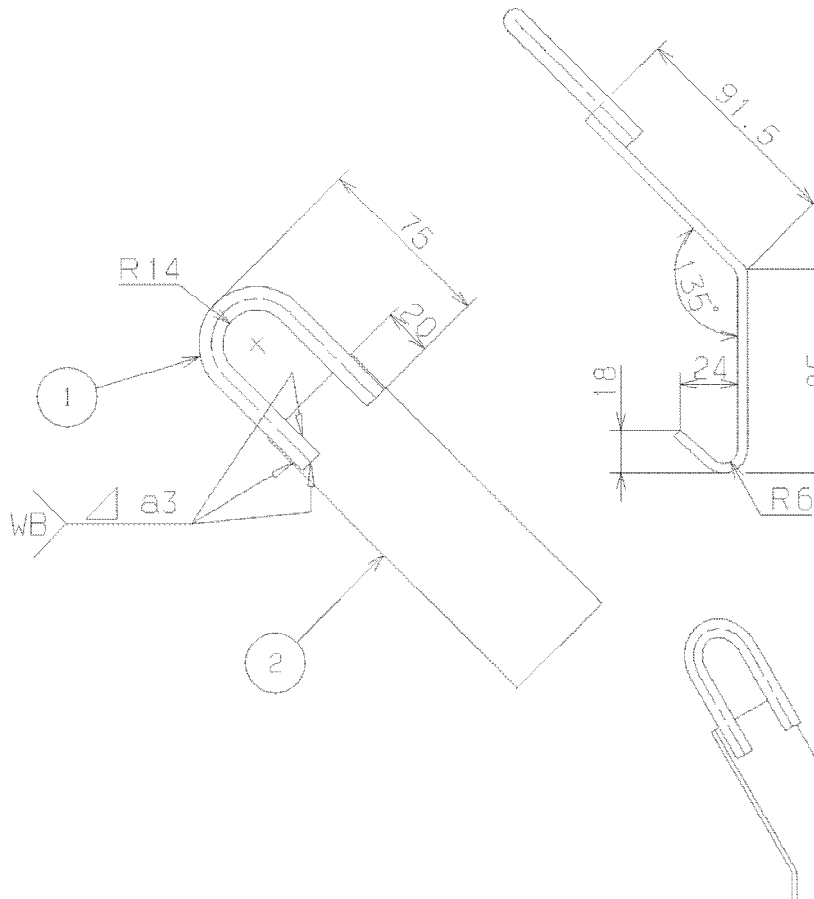
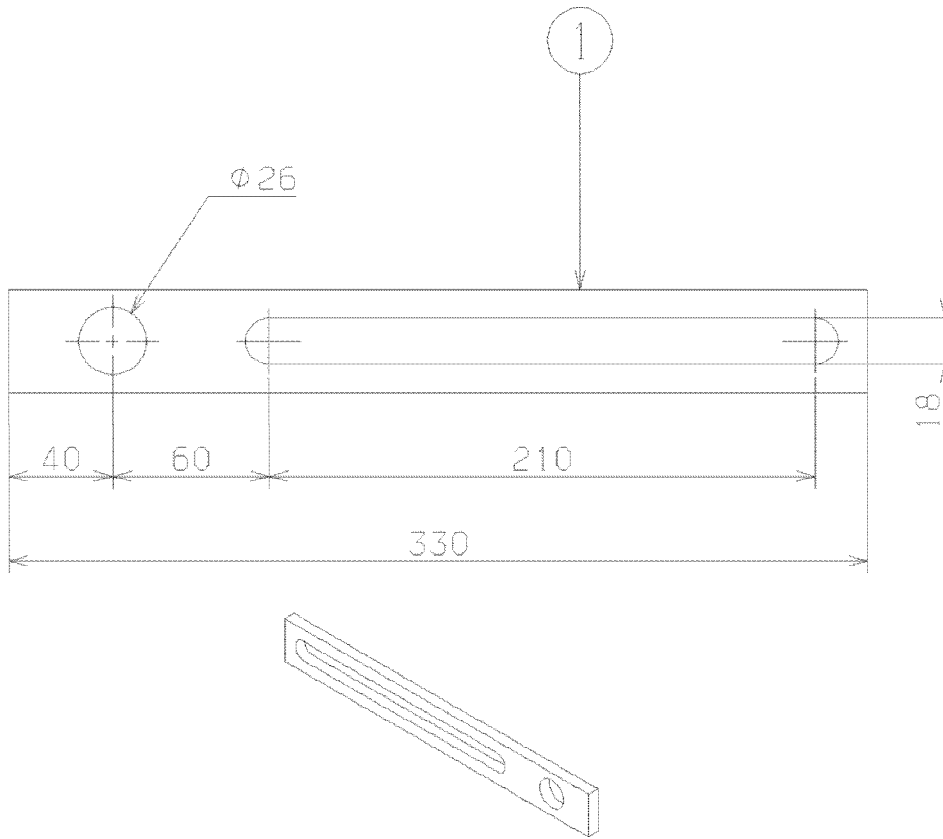

Figure 1
Lifting lug for radiator

Item	Quantity	Name
1	1	Round bar Ø10x162, Steel 2172-00
2	1	Flat bar 50x4x200, Steel 1312-00

Document Title: E-tool, NET 00009 Support	Function Group: 080	Information Type: Service Information	Date: 3/7/2026
Profile:			

E-tool, NET 00009 Support



NO260300

Figure 1
Support

Item	Quantity	Name
1	1	Flat bar 40x10, Steel 1312-00

Document Title: E-tool, NET 00015 Nozzle	Function Group: 080	Information Type: Service Information	Date: 3/7/2026
Profile:			

E-tool, NET 00015 Nozzle

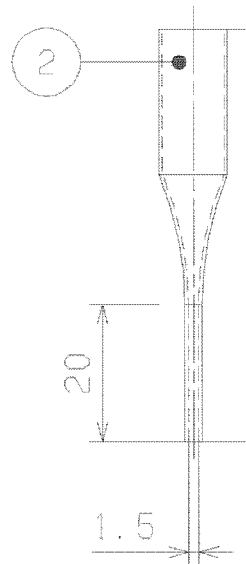
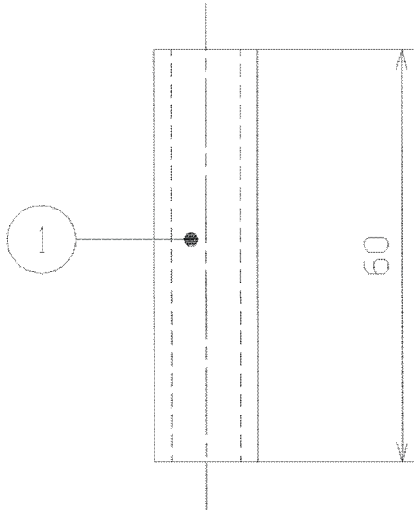

NO308001

Figure 1

Nozzle

Item	Quantity	Name
1	1	Plastic bar Ø15
2	1	Pipe Ø10

Document Title: E-tool, NET 00016 Assembly tool	Function Group: 080	Information Type: Service Information	Date: 3/7/2026
Profile:			

E-tool, NET 00016 Assembly tool

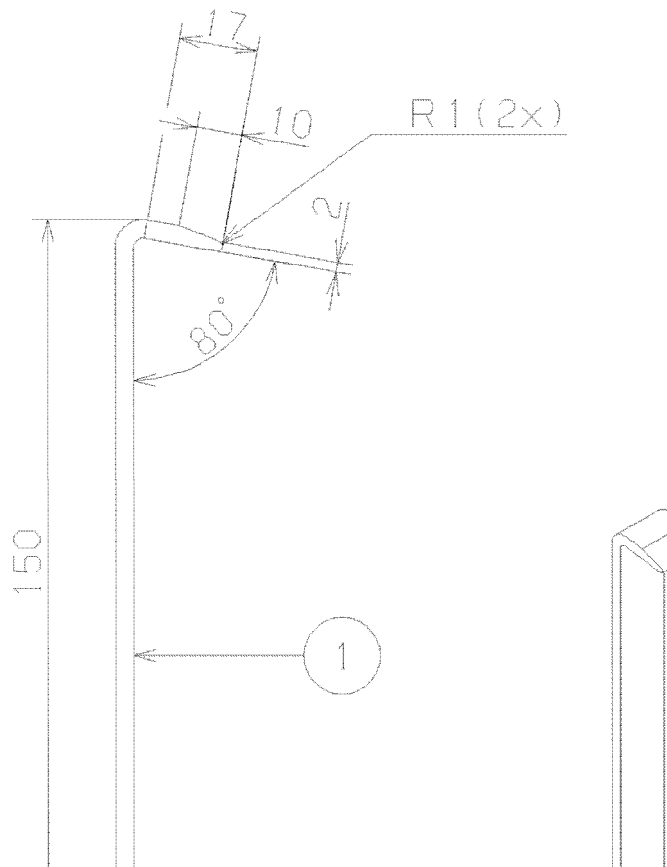

01

Figure 1
Assembly tool

Item	Quantity	Name
1	1	Flat bar 20x4

Document Title: E-tool, NET 00017 Assembly tool	Function Group: 080	Information Type: Service Information	Date: 3/7/2026
Profile:			

E-tool, NET 00017 Assembly tool

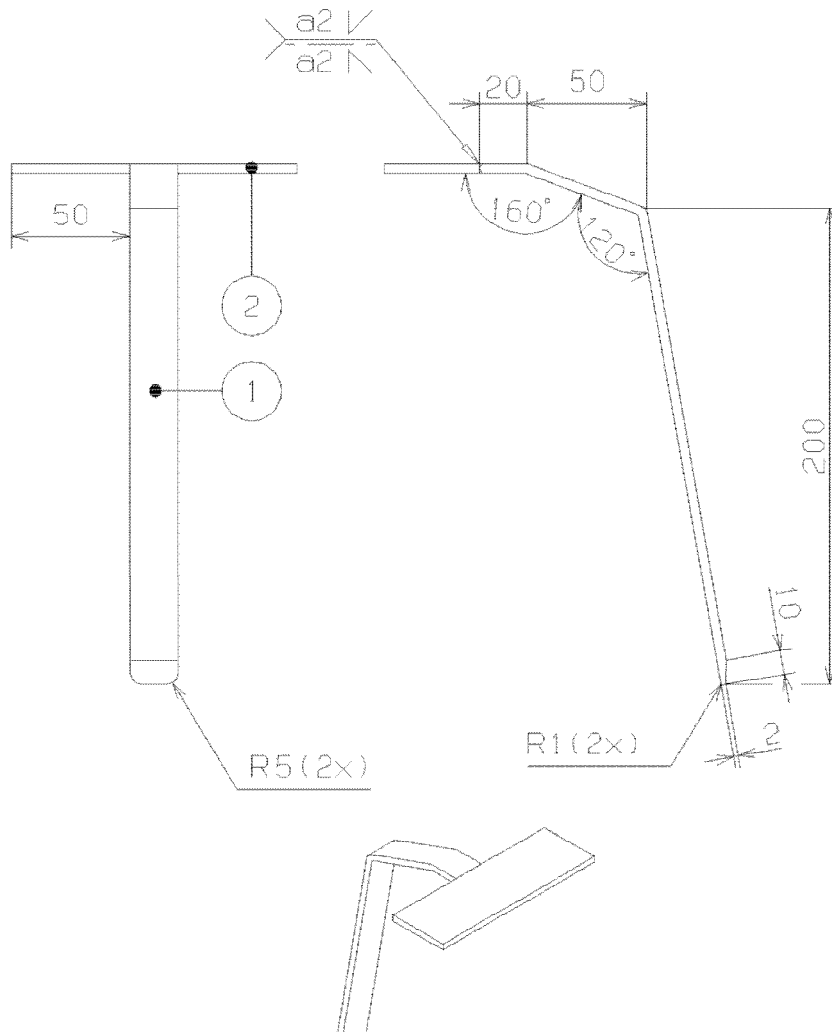

Figure 1
Assembly tool

Item	Quantity	Name
1	1	Flat bar 20x4
2	1	Flat bar 40x4x120

Document Title: E-tool, NET 00018 Holding arm	Function Group: 080	Information Type: Service Information	Date: 3/7/2026
Profile:			

E-tool, NET 00018 Holding arm

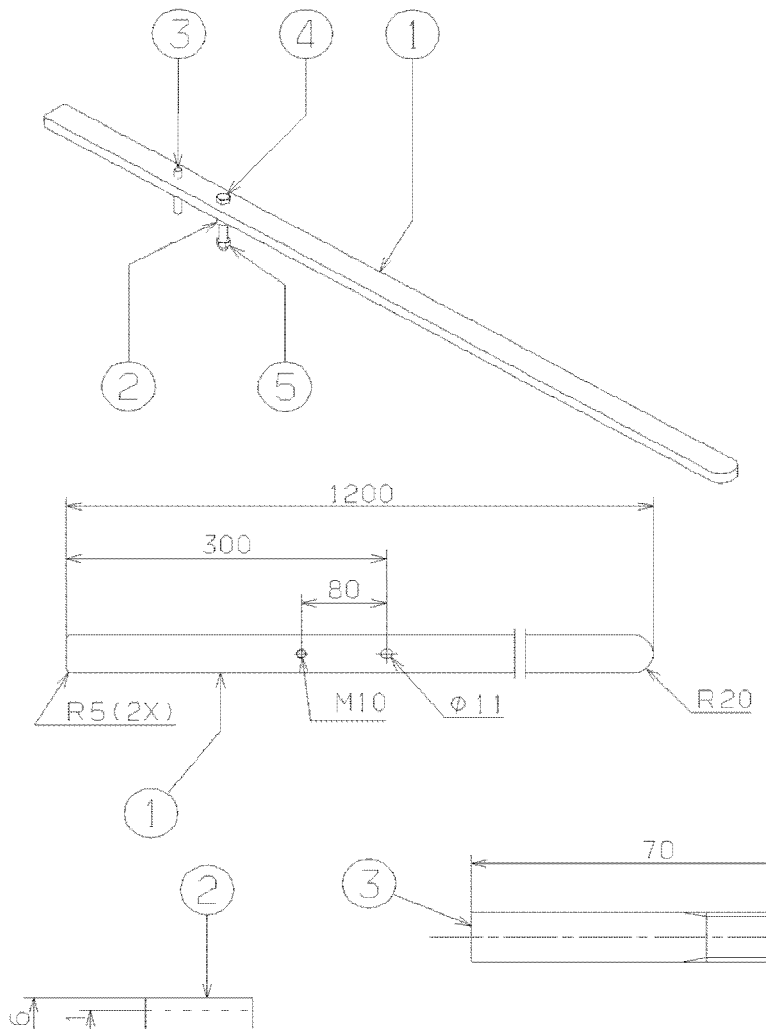

Figure 1
Holding arm

Item	Quantity	Name
1	1	Flat bar 40x15
2	1	Round bar Ø18
3	1	Bolt M6S 10x70
4	1	Bolt M6S 10x80
5	1	Nut M6M 10

Document Title: E-tool, NET 00019 Press disc	Function Group: 080	Information Type: Service Information	Date: 3/7/2026
Profile:			

E-tool, NET 00019 Press disc

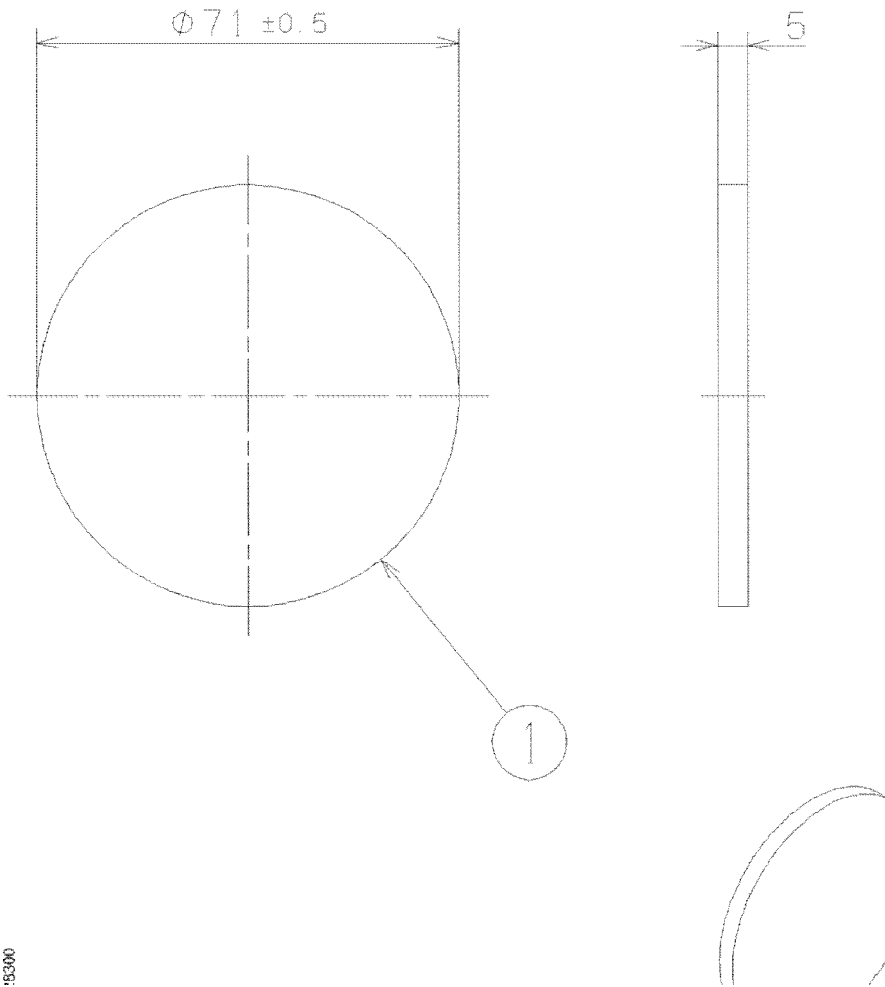

Figure 1
Press disc

Item	Quantity	Name
1	1	Round bar $\varnothing 75$, Steel 2225-05

Document Title: E-tool, NET 00020 Puller	Function Group: 080	Information Type: Service Information	Date: 3/7/2026
Profile:			

E-tool, NET 00020 Puller

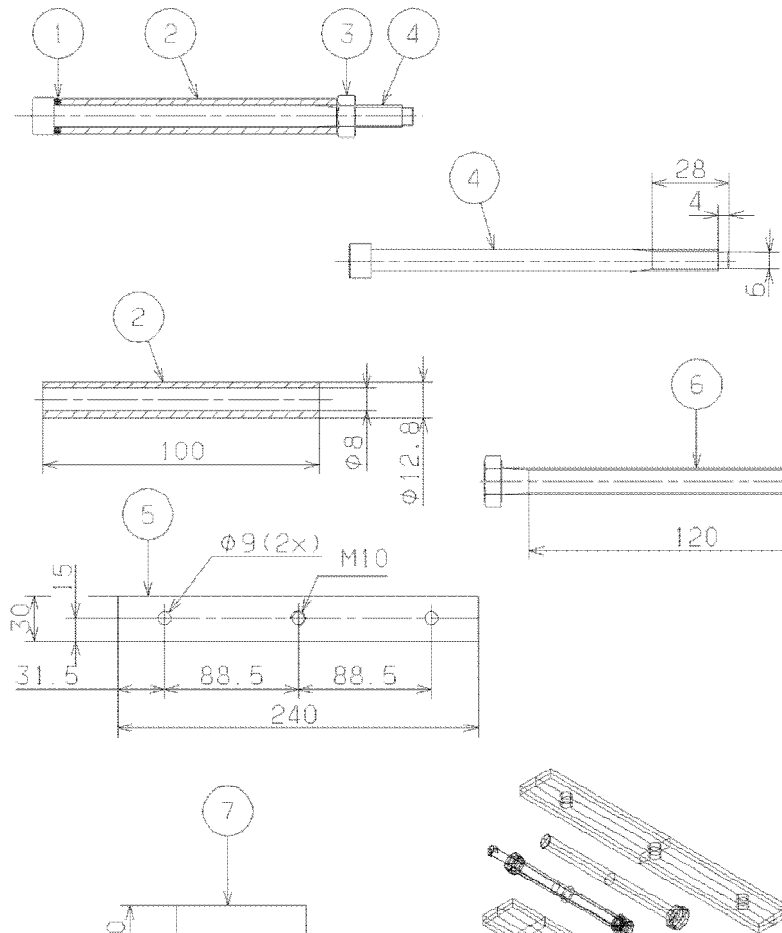

Figure 1

Puller

Item	Quantity	Name
1	2	O-ring 13.1x2.4
2	2	Round bar \varnothing 16, Steel 2172-00
3	4	Nut M8
4	2	Bolt MC6S 8x130
5	1	Flat bar 30x8, Steel 1312-00
6	1	Bolt M6S 10x130
7	1	Flat bar 30x8, Steel 1312-00

Document Title: E-tool, NET 00021 Press tool	Function Group: 080	Information Type: Service Information	Date: 3/7/2026
Profile:			

E-tool, NET 00021 Press tool

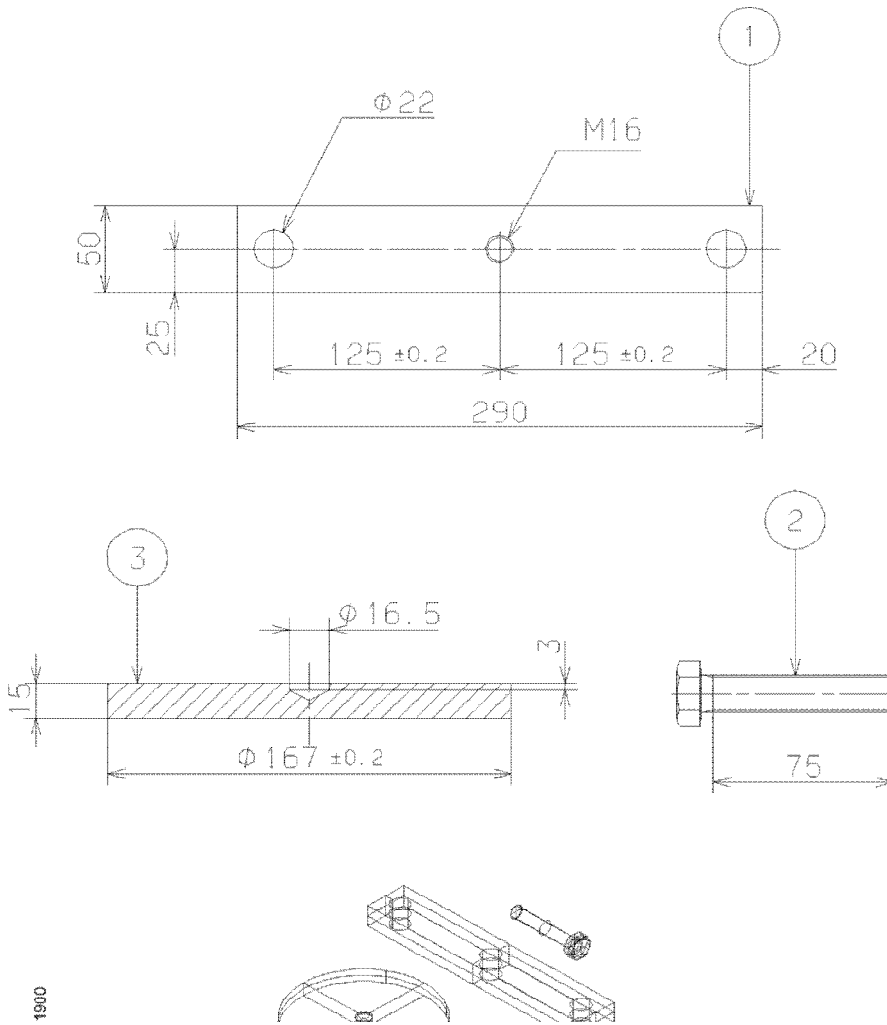

Figure 1
Press tool

Item	Quantity	Name
1	1	Flat bar 50x25, Steel 1312-00
2	1	Bolt M6S 16x80
3	1	Ø170 Steel 2172-00

Document Title: E-tool, NET 00022 Press tool	Function Group: 080	Information Type: Service Information	Date: 3/7/2026
Profile:			

E-tool, NET 00022 Press tool

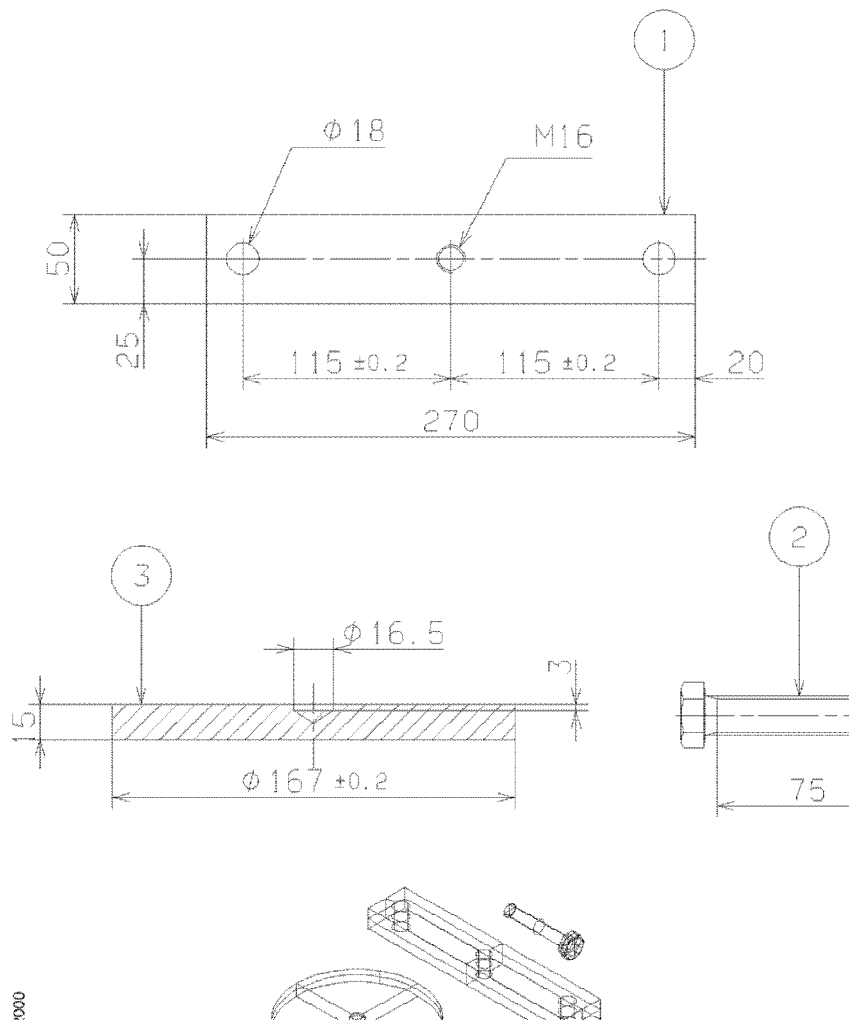

Figure 1
Press tool

Item	Quantity	Name
1	1	Flat bar 50x25, Steel 1312-00
2	1	Bolt M6S 16x80
3	1	$\phi 170$, Steel 2172-00

Document Title: Hydraulic oil, cleaning	Function Group: 160	Information Type: Service Information	Date: 3/7/2026
Profile:			

Hydraulic oil, cleaning

Op nbr 160-03

=

CAUTION

Observe strict cleanliness.

Cleaning of the hydraulic oil should be carried out:

- After major invasive work in the hydraulic system, e.g. in valve blocks, and after tank replacement or pump, hydraulic motor or cylinder failure.
- After an oil test showing contaminated oil.
- On machines with frequent hydraulic disturbances.

Oil cleaning can be carried out as follows:

- With the hydraulic system's internal filtration device.

When the hydraulic system's internal filtration device is used:

1. The hydraulic oil temperature must be at least 35°C.
2. Clean the filter canister in the hydraulic oil tank thoroughly and put in new filters.
3. Clean the oil for at least 3 hours during normal use of the machine.
4. Put new filters in the filter canister.

Document Title: Hydraulic oil, description	Function Group: 160	Information Type: Service Information	Date: 3/7/2026
Profile:			

Hydraulic oil, description

The oil contains selected additives that provide good oxidation stability, good corrosion protection and good lubricating properties, as well as compatibility with bearings containing lead alloys.

The ester base gives the oil a very high viscosity index and good properties at low temperature.

Oil should be stored under cover or in temperature-controlled premises. If oil is stored out of doors, the drums should be stored horizontally so that water cannot enter and drum labelling is not eradicated.

The oil should not be stored at temperatures above 60°C, or be exposed to strong sunlight or freezing temperatures.

Document Title: Hydraulic oil, specifications	Function Group: 160	Information Type: Service Information	Date: 3/7/2026
Profile:			

Hydraulic oil, specifications

Oil type	Viscosity	Ambient temperature	Miscibility	Remark
Handel 32 Mineral oil	ISO VG 32 HR	-30 to +35°C	Miscible with SHS 46	
Handel 46 Mineral oil	ISO VG 46 HR	-15 to +50°C	Miscible with SHS 32	
PANOLIN HLP SE SYNTH 46 (Biodegradable) Synthetic oil	Same as for mineral oil (Handel 46)	-15 to +50°C		Before changing from mineral oil to synthetic oil, contact Volvo Construction Equipment - Service
BP BIOHYD SE-S 46 (Biodegradable) Synthetic oil	Same as for mineral oil Handel 46	-15 to +50°C		Before changing from mineral oil to synthetic oil, contact Volvo Construction Equipment - Service

Document Title: Hydraulic oil, specifications	Function Group: 160	Information Type: Service Information	Date: 3/7/2026
Profile:			

Hydraulic oil, specifications

Oil type	Viscosity	Ambient temperature	Miscibility	Remark
Handel 32 Mineral oil	ISO VG 32 HR	-30 to +35°C	Miscible with SHS 46	
Handel 46 Mineral oil	ISO VG 46 HR	-15 to +50°C	Miscible with SHS 32	
PANOLIN HLP SE SYNTH 46 (Biodegradable) Synthetic oil	Same as for mineral oil (Handel 46)	-15 to +50°C		Before changing from mineral oil to synthetic oil, contact Volvo Construction Equipment - Service
BP BIOHYD SE-S 46 (Biodegradable) Synthetic oil	Same as for mineral oil Handel 46	-15 to +50°C		Before changing from mineral oil to synthetic oil, contact Volvo Construction Equipment - Service

Product: EC340 Volvo Excavator Service Manual

Full Download: <https://www.arepairmanual.com/downloads/ec340-volvo-excavator-service-manual/>

VOLVO

Service Information

Document Title: Hydraulic oil, storage and handling	Function Group: 160	Information Type: Service Information	Date: 3/7/2026
Profile:			

Hydraulic oil, storage and handling

- Hydraulic oil should be stored in well-sealed tanks or drums.
- Containers used for shipping hydraulic oil should not be used for any other purpose.

Sample manual. Download All 1128 pages at:

<https://www.arepairmanual.com/downloads/ec340-volvo-excavator-service-manual/>