

Document Title: General dimensions	Function Group: 030	Information Type: Service Information	Date: 11/26/2025
Profile:			

General dimensions

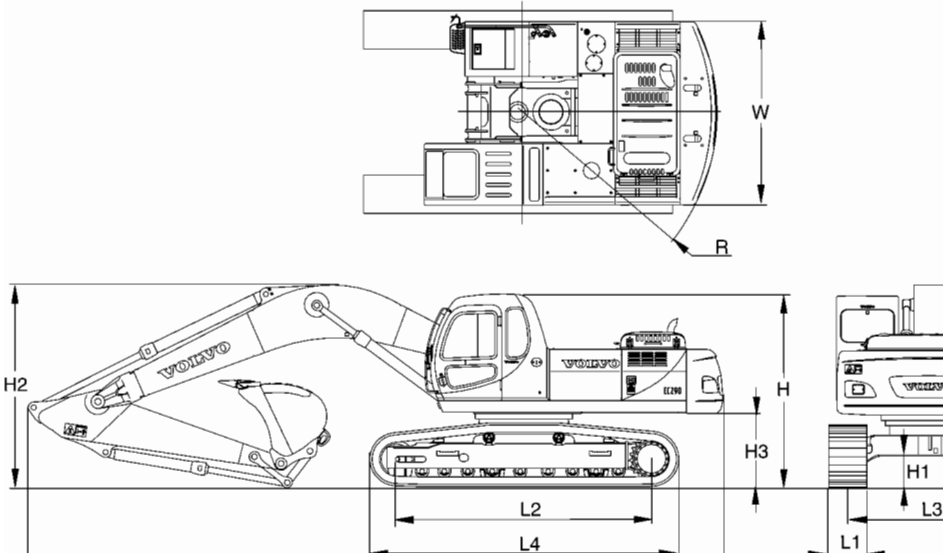

Figure 1
Dimensions of machine

Dimensions, whole machine (Mono boom, LC)

		Symbol	Unit	Standard	Option			Remark
Front digging unit	Boom length	-	mm (ft)	6200 (20" 4")				
	Arm length	-	mm (ft)	3050 (10" 0")	2550 (8" 4")	4000 (13" 1")		
Overall height	Cab	H	mm (ft)	3030 (9" 1")				
	Boom	H2	mm (ft)	3200 (10" 6")	3370 (11" 6")	3620 (11" 1")		
Ground clearance	Lower frame	H1	mm (ft)	*480 (1" 7")				
	Counterweight	H3	mm (ft)	*1125 (3" 8")				
Overall length		L	mm (ft)	10660 (35")	10760 (35" 4")	10710 (35" 2")		
Tumbler length		L2	mm (ft)	4015 (13" 2")				
Superstructure	Overall width	W	mm (ft)	2840 (9" 4")				
	Turning radius	R	mm (ft)	3150 (10" 4")				
Under	Shoe width	L1	mm (ft)	600	700	800	900	@900 @Swamp

Product: EC290 Volvo Excavator Service Manual

Full Download: <https://www.arepairmanual.com/downloads/ec290-volvo-excavator-service-manual/>

Under carriage	Track gauge	L3	mm (ft)	2590 (8" 6")					shoe
	Overall width	B	mm (ft)	3190 (10" 6")	3290 (10" 10")	3390 (11" 1")	3490 (11" 5")	3490 (11" 5")	
	Track length	L4	mm (ft)	4870 (16")					

*: Without shoe grouser

Dimensions, whole machine (Mono boom, NLC)

		Symb ol	Unit	Standard	Option				Remark
Under carriage	Shoe width	L1	mm (ft)	600 (1" 11")	700 (2" 3")	800 (2" 7")	900 (2" 11")	@900 (2" 11")	@Swamp shoe
	Track gauge	L3	mm (ft)	2390 (7" 10")					
	Overall width	B	mm (ft)	2990 (9" 10")	3090 (10" 2")	3190 (10" 6")	3290 (10" 10")	3290 (10" 10")	
	Track length	L4	mm (ft)	4870 (16")					

Sample manual. Download All 2841 pages at:

<https://www.arepairmanual.com/downloads/ec290-volvo-excavator-service-manual/>

Document Title: General dimensions	Function Group: 030	Information Type: Service Information	Date: 11/26/2025
Profile:			

General dimensions

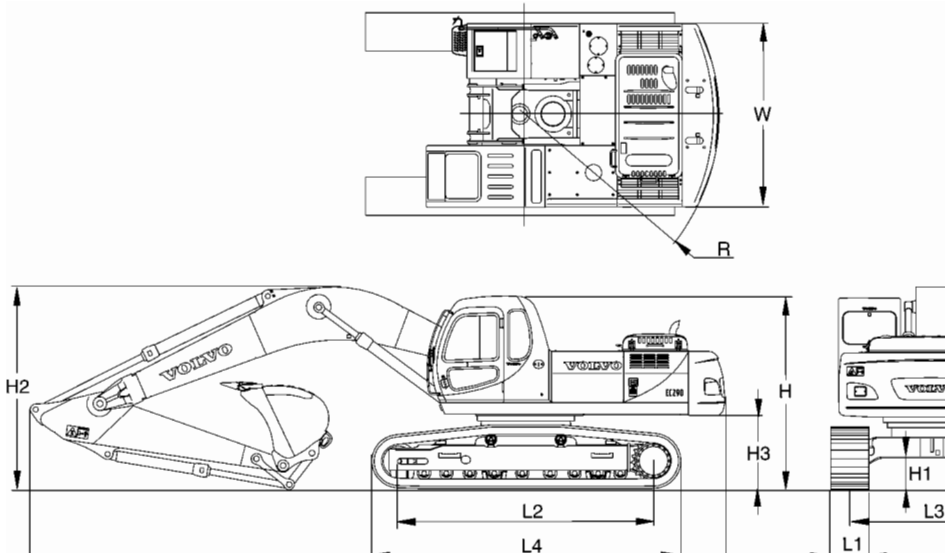

Figure 1

Dimensions of machine

Dimensions, whole machine (Mono boom, LC)

		Symb ol	Unit	Standard	Option			Remark
Front digging unit	Boom length	-	mm (ft)	6200 (20" 4")				
	Arm length	-	mm (ft)	3050 (10" 0")	2550 (8" 4")	4000 (13" 1")		
Overall height	Cab	H	mm (ft)	3030 (9" 1")				
	Boom	H2	mm (ft)	3200 (10" 6")	3370 (11" 6")	3620 (11" 1")		
Ground clearance	Lower frame	H1	mm (ft)	*480 (1" 7")				
	Counterweight	H3	mm (ft)	*1125 (3" 8")				
Overall length		L	mm (ft)	10660 (35")	10760 (35" 4")	10710 (35" 2")		
Tumbler length		L2	mm (ft)	4015 (13" 2")				
Superstructure	Overall width	W	mm (ft)	2840 (9" 4")				
	Turning radius	R	mm (ft)	3150 (10" 4")				
Under	Shoe width	L1	mm (ft)	600	700	800	900	@900 @Swamp

carriage				(1" 11")	(2" 3")	(2" 7")	(2" 11")	(2" 11")	shoe
	Track gauge	L3	mm (ft)	2590 (8" 6")					
	Overall width	B	mm (ft)	3190 (10" 6")	3290 (10" 10")	3390 (11" 1")	3490 (11" 5")	3490 (11" 5")	
Track length	L4	mm (ft)	4870 (16")						

*: Without shoe grouser

Dimensions, whole machine (Mono boom, NLC)

		Symb ol	Unit	Standard	Option				Remark
Under carriage	Shoe width	L1	mm (ft)	600 (1" 11")	700 (2" 3")	800 (2" 7")	900 (2" 11")	@900 (2" 11")	@Swamp shoe
	Track gauge	L3	mm (ft)	2390 (7" 10")					
	Overall width	B	mm (ft)	2990 (9" 10")	3090 (10" 2")	3190 (10" 6")	3290 (10" 10")	3290 (10" 10")	
	Track length	L4	mm (ft)	4870 (16")					

Document Title: General dimensions	Function Group: 030	Information Type: Service Information	Date: 11/26/2025
Profile:			

General dimensions

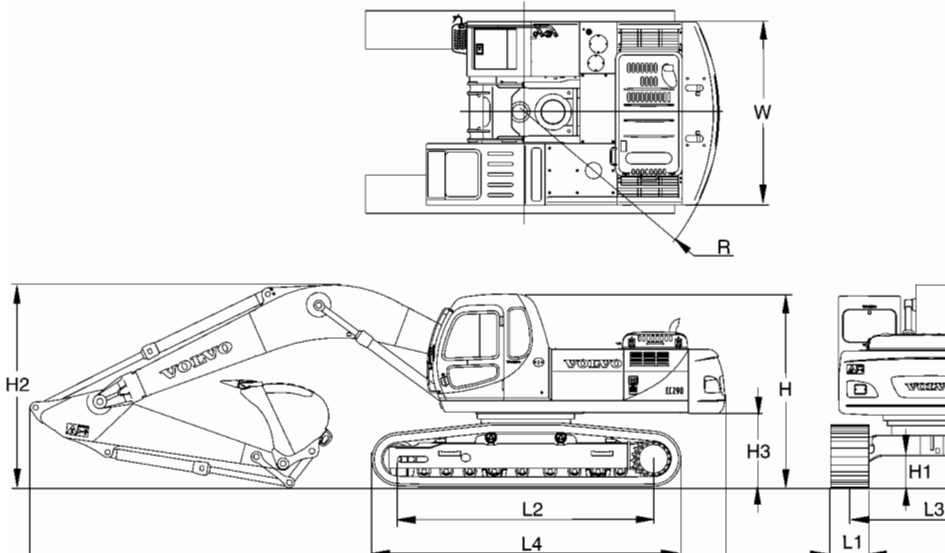

Figure 1
Dimensions of machine

Dimensions, whole machine (Mono boom, LC)

		Symb ol	Unit	Standard	Option			Remark
Front digging unit	Boom length	-	mm (ft)	6200 (20" 4")				
	Arm length	-	mm (ft)	3050 (10" 0")	2550 (8" 4")	4000 (13" 1")		
Overall height	Cab	H	mm (ft)	3030 (9" 1")				
	Boom	H2	mm (ft)	3200 (10" 6")	3370 (11" 6")	3620 (11" 1")		
Ground clearance	Lower frame	H1	mm (ft)	*480 (1" 7")				
	Counterweight	H3	mm (ft)	*1125 (3" 8")				
Overall length		L	mm (ft)	10660 (35")	10760 (35" 4")	10710 (35" 2")		
Tumbler length		L2	mm (ft)	4015 (13" 2")				
Superstructure	Overall width	W	mm (ft)	2840 (9" 4")				
	Turning radius	R	mm (ft)	3150 (10" 4")				
Under	Shoe width	L1	mm (ft)	600	700	800	900	@900 @Swamp

carriage				(1" 11")	(2" 3")	(2" 7")	(2" 11")	(2" 11")	shoe
	Track gauge	L3	mm (ft)	2590 (8" 6")					
	Overall width	B	mm (ft)	3190 (10" 6")	3290 (10" 10")	3390 (11" 1")	3490 (11" 5")	3490 (11" 5")	
Track length	L4	mm (ft)	4870 (16")						

*: Without shoe grouser

Dimensions, whole machine (Mono boom, NLC)

		Symb ol	Unit	Standard	Option				Remark
Under carriage	Shoe width	L1	mm (ft)	600 (1" 11")	700 (2" 3")	800 (2" 7")	900 (2" 11")	@900 (2" 11")	@Swamp shoe
	Track gauge	L3	mm (ft)	2390 (7" 10")					
	Overall width	B	mm (ft)	2990 (9" 10")	3090 (10" 2")	3190 (10" 6")	3290 (10" 10")	3290 (10" 10")	
	Track length	L4	mm (ft)	4870 (16")					

Document Title: Location of components	Function Group: 030	Information Type: Service Information	Date: 11/26/2025
Profile:			

Location of components

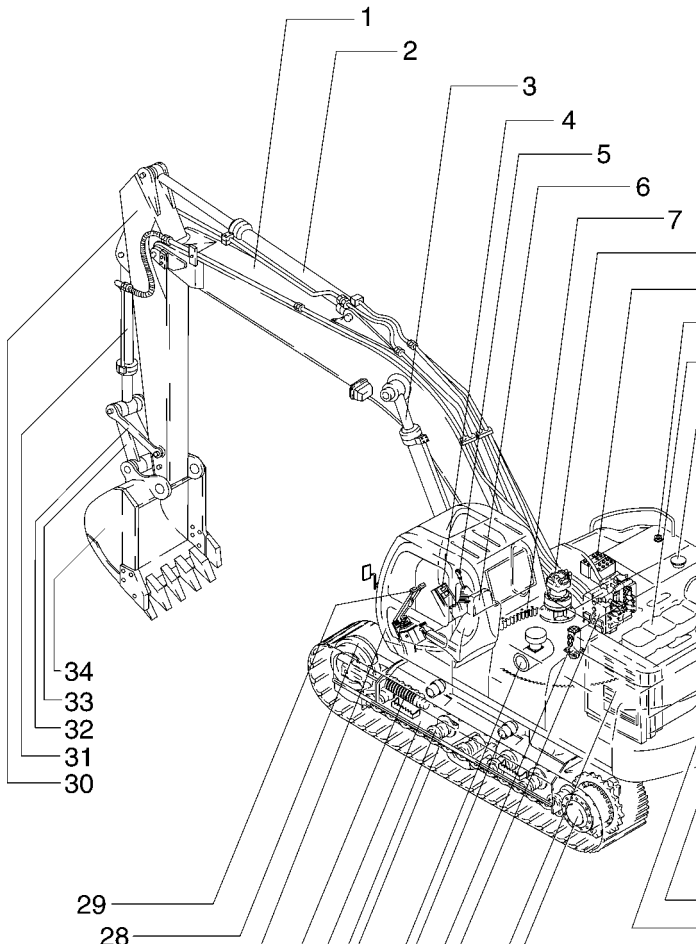

Figure 1

Location of components

1	Boom	13	Muffler	25	Undercarriage
2	Arm cylinder	14	Cowl	26	Spring package
3	Boom cylinder	15	Counterweight	27	Cab
4	Switch board	16	Hydraulic pump	28	Idler
5	Control lever	17	Track motor and gearbox	29	Remote control lever (Travel)
6	Operator seat	18	Radiator and oil cooler	30	Arm
7	Slew gear	19	Main control valve	31	Bucket cylinder
8	Slew motor and gearbox	20	Center passage	32	Connecting rod
9	Battery	21	Top roller	33	Link
10	Fuel tank	22	Air cleaner	34	Bucket
11	Engine	23	Track link		
12	Hydraulic tank	24	Bottom roller		

Document Title: Location of components	Function Group: 030	Information Type: Service Information	Date: 11/26/2025
Profile:			

Location of components

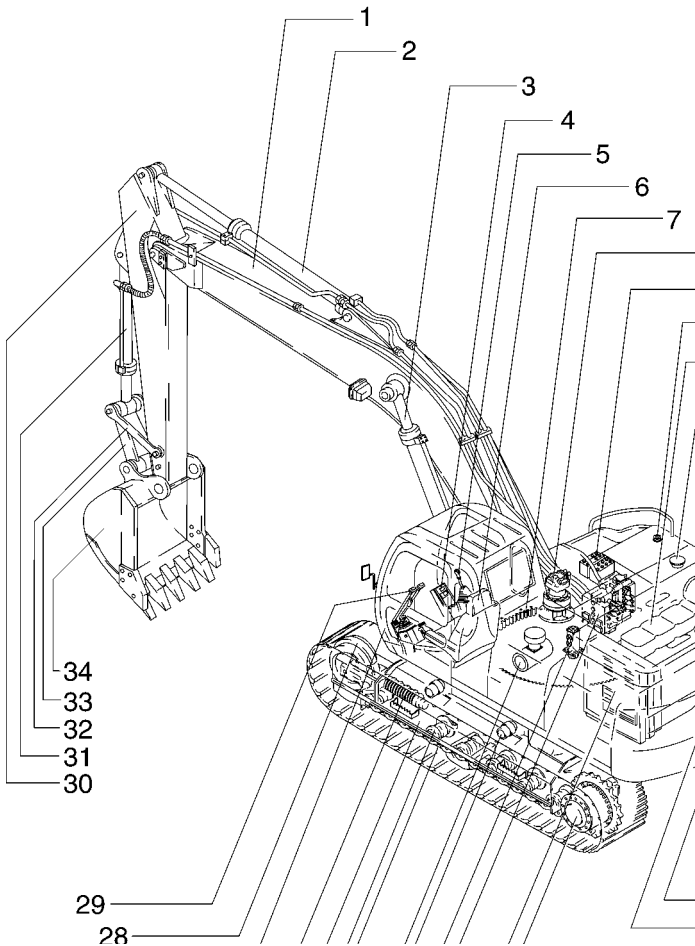

Figure 1
Location of components

1 Boom	13 Muffler	25 Undercarriage
2 Arm cylinder	14 Cowl	26 Spring package
3 Boom cylinder	15 Counterweight	27 Cab
4 Switch board	16 Hydraulic pump	28 Idler
5 Control lever	17 Track motor and gearbox	29 Remote control lever (Travel)
6 Operator seat	18 Radiator and oil cooler	30 Arm
7 Slew gear	19 Main control valve	31 Bucket cylinder
8 Slew motor and gearbox	20 Center passage	32 Connecting rod
9 Battery	21 Top roller	33 Link
10 Fuel tank	22 Air cleaner	34 Bucket
11 Engine	23 Track link	
12 Hydraulic tank	24 Bottom roller	

Document Title: Location of components	Function Group: 030	Information Type: Service Information	Date: 11/26/2025
Profile:			

Location of components

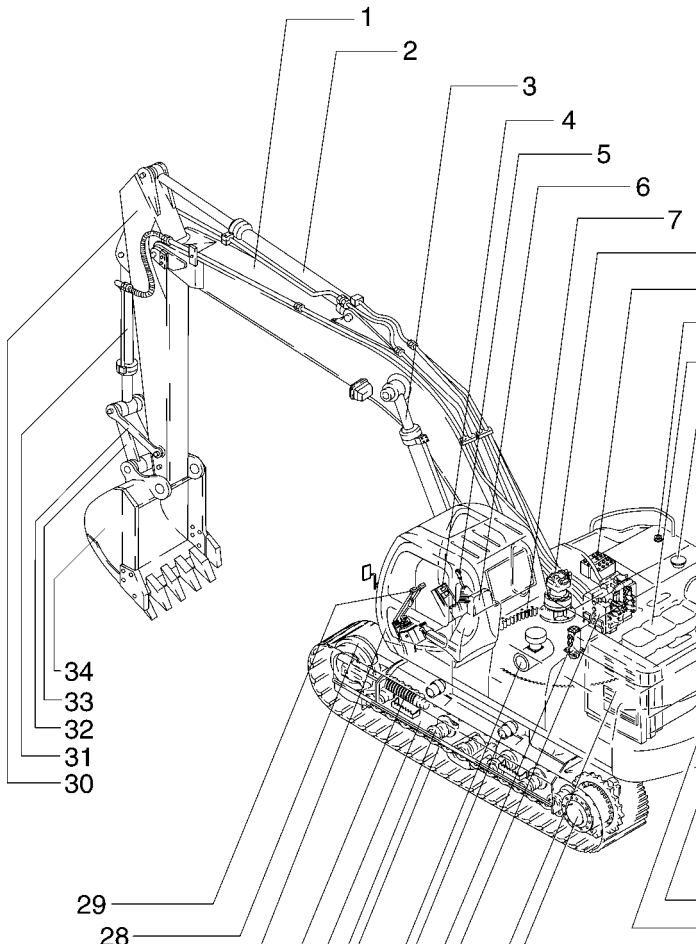

Figure 1

Location of components

1	Boom	13	Muffler	25	Undercarriage
2	Arm cylinder	14	Cowl	26	Spring package
3	Boom cylinder	15	Counterweight	27	Cab
4	Switch board	16	Hydraulic pump	28	Idler
5	Control lever	17	Track motor and gearbox	29	Remote control lever (Travel)
6	Operator seat	18	Radiator and oil cooler	30	Arm
7	Slew gear	19	Main control valve	31	Bucket cylinder
8	Slew motor and gearbox	20	Center passage	32	Connecting rod
9	Battery	21	Top roller	33	Link
10	Fuel tank	22	Air cleaner	34	Bucket
11	Engine	23	Track link		
12	Hydraulic tank	24	Bottom roller		

Document Title: Measurement conversion tables	Function Group: 030	Information Type: Service Information	Date: 11/26/2025
Profile:			

Measurement conversion tables

Length

Unit	cm	m	km	in	ft	yd	mile
cm	1	0.01	0.00001	0.3937	0.03281	0.01094	0.000006
m	100	1	0.001	39.37	3.2808	1.0936	0.00062
km	100000	1000	1	39370.7	3280.8	1093.6	0.62137
in	2.54	0.0254	0.000025	1	0.08333	0.02777	0.000015
ft	30.48	0.3048	0.000304	12	1	0.3333	0.000189
yd	91.44	0.9144	0.000914	36	3	1	0.000568
mile	160930	1609.3	1.6093	63360	5280	1760	1

1 mm = 0.1 cm, 1 mm = 0.001 m

Area

Unit	cm ²	m ²	km ²	a	ft ²	yd ²	in ²
cm ²	1	0.0001	-	0.000001	0.001076	0.000012	0.155000
m ²	10000	1	0.000001	0.01	10.764	1.1958	1550.000
km ²	-	1000000	1	10000	1076400	1195800	-
a	0.01	100	0.0001	1	1076.4	119.58	-
ft ²	-	0.092903	-	0.000929	1	0.1111	144.000
yd ²	-	0.83613	-	0.008361	9	1	1296.00
in ²	6.4516	0.000645	-	-	0.006943	0.000771	1

1 ha = 100 a, 1 mile² = 259 ha = 2.59 km²

Volume

Unit	cm ³ = cc	m ³	Liter	in ³	ft ³	yd ³
cm ³ = m liter	1	0.000001	0.001	0.061024	0.000035	0.000001
m ³	1000000	1	1000	61024	35.315	1.30796
Liter	1000	0.001	1	61.024	0.035315	0.001308
in ³	16.387	0.000016	0.01638	1	0.000578	0.000021
ft ³	28316.8	0.028317	28.317	1728	1	0.03704
yd ³	764529.8	0.76453	764.53	46656	27	1

1 gal (US) = 3785.41 cm³ = 231 in³ = 0.83267 gal (US)

Weight

Unit	g	kg	t	oz	lb
g	1	0.001	0.000001	0.03527	0.0022
kg	1000	1	0.001	35.273	2.20459
t	1000000	1000	1	35273	2204.59

oz	28.3495	0.02835	0.000028	1	0.0625
lb	453.592	0.45359	0.000454	16	1
1 tonne (metric) = 1.1023 ton (US) = 0.9842 ton (UK)					

Pressure

Unit	kgf/cm ²	bar	Pa=N/m ²	kPa	lbf / in ²	lbf / ft ²
kgf / cm ²	1	0.98067	98066.5	98.0665	14.2233	2048.16
bar	1.01972	1	100000	100	14.5037	2088.6
Pa=N / m ²	0.00001	0.001	1	0.001	0.00015	0.02086
kPa	0.01020	0.01	1000	1	0.14504	20.886
lbf / in ²	0.07032	0.0689	6894.76	6.89476	1	144
lbf / ft ²	0.00047	0.00047	47.88028	0.04788	0.00694	1
1 kgf / cm ² = 735.56 Torr (mmHg) = 0.96784 atm						

Approximate conversions

SI Unit	Conversion Factor	Non-SI Unit	Conversion Factor	SI Unit
Torque				
newton meter (N·m)	x 10.2	= kgf·cm	x 0.8664	= (lbf·in)
newton meter (N·m)	x 0.74	= lb·ft	x 1.36	= N·m
newton meter (N·m)	x 0.102	= kgf·m	x 7.22	= (lbf·ft)
Pressure (Pa = N / m²)				
kilopascal (kPa)	x 4.0	= in. H ₂ O	x 0.249	= kPa
kilopascal (kPa)	x 0.30	= in. Hg	x 3.38	= kPa
kilopascal (kPa)	x 0.145	= psi	x 6.89	= kPa
(bar)	x 14.5	= psi	x 0.069	= (bar)
(kgf / cm ²)	x 14.22	= psi	x 0.070	= (kgf / cm ²)
(newton / mm ²)	x 145.04	= psi	x 0.069	= (bar)
megapascal (MPa)	x 145	= psi	x 0.00689	= MPa
Power (W = J / s)				
kilowatt (kW)	x 1.36	= PS (cv)	x 0.736	= kW
kilowatt (kW)	x 1.34	= HP	x 0.746	= kW
kilowatt (kW)	x 0.948	= Btu / s	x 1.055	= kW
watt (W)	x 0.74	= ft·lb / s	x 1.36	= W
Energy (J = N·m)				
kilojoule (kJ)	x 0.948	= Btu	x 1.055	= kJ
joule (J)	x 0.239	= calorie	x 4.19	= J
Velocity and Acceleration				
meter per sec ² (m / s ²)	x 3.28	= ft / s ²	x 0.305	= m / s ²
meter per sec (m / s)	x 3.28	= ft / s	x 0.305	= m / s
kilometer per hour (km / h)	x 0.62	= mph	x 1.61	= km / h
Horse power /torque				
BHP x 5252 rpm = TQ (lb·ft)			TQ x rpm 5252 = B.H.P.	
Temperature				
°C = (°F - 32) / 1.8		°F = (°C x 1.8) + 32		
Flow Rate				
liter / min (dm ³ / min)	x 0.264	= US gal / min x 3.785	= liter / min	

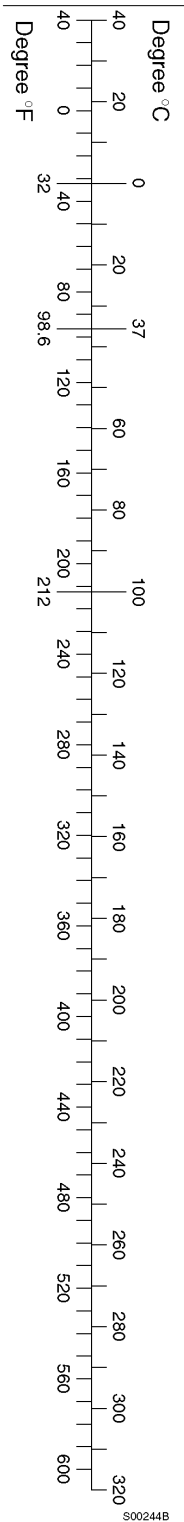

S00244B

Note : () non-si unit

Document Title: Measurement conversion tables	Function Group: 030	Information Type: Service Information	Date: 11/26/2025
Profile:			

Measurement conversion tables

Length

Unit	cm	m	km	in	ft	yd	mile
cm	1	0.01	0.00001	0.3937	0.03281	0.01094	0.000006
m	100	1	0.001	39.37	3.2808	1.0936	0.00062
km	100000	1000	1	39370.7	3280.8	1093.6	0.62137
in	2.54	0.0254	0.000025	1	0.08333	0.02777	0.000015
ft	30.48	0.3048	0.000304	12	1	0.3333	0.000189
yd	91.44	0.9144	0.000914	36	3	1	0.000568
mile	160930	1609.3	1.6093	63360	5280	1760	1

1 mm = 0.1 cm, 1 mm = 0.001 m

Area

Unit	cm ²	m ²	km ²	a	ft ²	yd ²	in ²
cm ²	1	0.0001	-	0.000001	0.001076	0.000012	0.155000
m ²	10000	1	0.000001	0.01	10.764	1.1958	1550.000
km ²	-	1000000	1	10000	1076400	1195800	-
a	0.01	100	0.0001	1	1076.4	119.58	-
ft ²	-	0.092903	-	0.000929	1	0.1111	144.000
yd ²	-	0.83613	-	0.008361	9	1	1296.00
in ²	6.4516	0.000645	-	-	0.006943	0.000771	1

1 ha = 100 a, 1 mile² = 259 ha = 2.59 km²

Volume

Unit	cm ³ = cc	m ³	Liter	in ³	ft ³	yd ³
cm ³ = m liter	1	0.000001	0.001	0.061024	0.000035	0.000001
m ³	1000000	1	1000	61024	35.315	1.30796
Liter	1000	0.001	1	61.024	0.035315	0.001308
in ³	16.387	0.000016	0.01638	1	0.000578	0.000021
ft ³	28316.8	0.028317	28.317	1728	1	0.03704
yd ³	764529.8	0.76453	764.53	46656	27	1

1 gal (US) = 3785.41 cm³ = 231 in³ = 0.83267 gal (US)

Weight

Unit	g	kg	t	oz	lb
g	1	0.001	0.000001	0.03527	0.0022
kg	1000	1	0.001	35.273	2.20459
t	1000000	1000	1	35273	2204.59

oz	28.3495	0.02835	0.000028	1	0.0625
lb	453.592	0.45359	0.000454	16	1
1 tonne (metric) = 1.1023 ton (US) = 0.9842 ton (UK)					

Pressure

Unit	kgf/cm ²	bar	Pa=N/m ²	kPa	lbf / in ²	lbf / ft ²
kgf / cm ²	1	0.98067	98066.5	98.0665	14.2233	2048.16
bar	1.01972	1	100000	100	14.5037	2088.6
Pa=N / m ²	0.00001	0.001	1	0.001	0.00015	0.02086
kPa	0.01020	0.01	1000	1	0.14504	20.886
lbf / in ²	0.07032	0.0689	6894.76	6.89476	1	144
lbf / ft ²	0.00047	0.00047	47.88028	0.04788	0.00694	1
1 kgf / cm ² = 735.56 Torr (mmHg) = 0.96784 atm						

Approximate conversions

SI Unit	Conversion Factor	Non-SI Unit	Conversion Factor	SI Unit
Torque				
newton meter (N·m)	x 10.2	= kgf·cm	x 0.8664	= (lbf·in)
newton meter (N·m)	x 0.74	= lb·ft	x 1.36	= N·m
newton meter (N·m)	x 0.102	= kgf·m	x 7.22	= (lbf·ft)
Pressure (Pa = N / m²)				
kilopascal (kPa)	x 4.0	= in. H ₂ O	x 0.249	= kPa
kilopascal (kPa)	x 0.30	= in. Hg	x 3.38	= kPa
kilopascal (kPa)	x 0.145	= psi	x 6.89	= kPa
(bar)	x 14.5	= psi	x 0.069	= (bar)
(kgf / cm ²)	x 14.22	= psi	x 0.070	= (kgf / cm ²)
(newton / mm ²)	x 145.04	= psi	x 0.069	= (bar)
megapascal (MPa)	x 145	= psi	x 0.00689	= MPa
Power (W = J / s)				
kilowatt (kW)	x 1.36	= PS (cv)	x 0.736	= kW
kilowatt (kW)	x 1.34	= HP	x 0.746	= kW
kilowatt (kW)	x 0.948	= Btu / s	x 1.055	= kW
watt (W)	x 0.74	= ft·lb / s	x 1.36	= W
Energy (J = N·m)				
kilojoule (kJ)	x 0.948	= Btu	x 1.055	= kJ
joule (J)	x 0.239	= calorie	x 4.19	= J
Velocity and Acceleration				
meter per sec ² (m / s ²)	x 3.28	= ft / s ²	x 0.305	= m / s ²
meter per sec (m / s)	x 3.28	= ft / s	x 0.305	= m / s
kilometer per hour (km / h)	x 0.62	= mph	x 1.61	= km / h
Horse power /torque				
BHP x 5252 rpm = TQ (lb·ft)			TQ x rpm 5252 = B.H.P.	
Temperature				
°C = (°F - 32) / 1.8		°F = (°C x 1.8) + 32		
Flow Rate				
liter / min (dm ³ / min)	x 0.264	= US gal / min x 3.785	= liter / min	

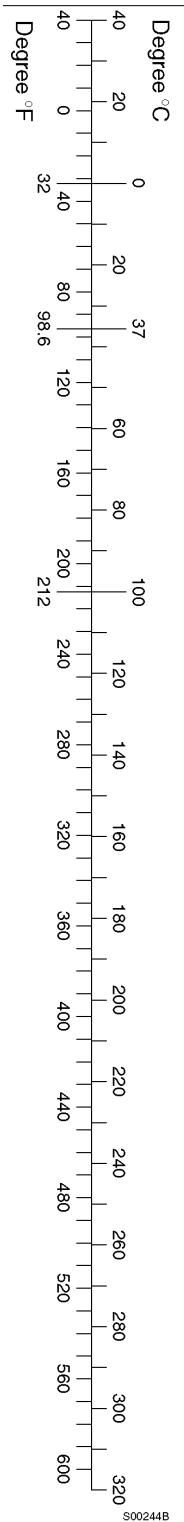

S00244B

Note : () non-si unit

Document Title: Measurement conversion tables	Function Group: 030	Information Type: Service Information	Date: 11/26/2025
Profile:			

Measurement conversion tables

Length

Unit	cm	m	km	in	ft	yd	mile
cm	1	0.01	0.00001	0.3937	0.03281	0.01094	0.000006
m	100	1	0.001	39.37	3.2808	1.0936	0.00062
km	100000	1000	1	39370.7	3280.8	1093.6	0.62137
in	2.54	0.0254	0.000025	1	0.08333	0.02777	0.000015
ft	30.48	0.3048	0.000304	12	1	0.3333	0.000189
yd	91.44	0.9144	0.000914	36	3	1	0.000568
mile	160930	1609.3	1.6093	63360	5280	1760	1

1 mm = 0.1 cm, 1 mm = 0.001 m

Area

Unit	cm ²	m ²	km ²	a	ft ²	yd ²	in ²
cm ²	1	0.0001	-	0.000001	0.001076	0.000012	0.155000
m ²	10000	1	0.000001	0.01	10.764	1.1958	1550.000
km ²	-	1000000	1	10000	1076400	1195800	-
a	0.01	100	0.0001	1	1076.4	119.58	-
ft ²	-	0.092903	-	0.000929	1	0.1111	144.000
yd ²	-	0.83613	-	0.008361	9	1	1296.00
in ²	6.4516	0.000645	-	-	0.006943	0.000771	1

1 ha = 100 a, 1 mile² = 259 ha = 2.59 km²

Volume

Unit	cm ³ = cc	m ³	Liter	in ³	ft ³	yd ³
cm ³ = m liter	1	0.000001	0.001	0.061024	0.000035	0.000001
m ³	1000000	1	1000	61024	35.315	1.30796
Liter	1000	0.001	1	61.024	0.035315	0.001308
in ³	16.387	0.000016	0.01638	1	0.000578	0.000021
ft ³	28316.8	0.028317	28.317	1728	1	0.03704
yd ³	764529.8	0.76453	764.53	46656	27	1

1 gal (US) = 3785.41 cm³ = 231 in³ = 0.83267 gal (US)

Weight

Unit	g	kg	t	oz	lb
g	1	0.001	0.000001	0.03527	0.0022
kg	1000	1	0.001	35.273	2.20459
t	1000000	1000	1	35273	2204.59

oz	28.3495	0.02835	0.000028	1	0.0625
lb	453.592	0.45359	0.000454	16	1
1 tonne (metric) = 1.1023 ton (US) = 0.9842 ton (UK)					

Pressure

Unit	kgf/cm ²	bar	Pa=N/m ²	kPa	lbf / in ²	lbf / ft ²
kgf / cm ²	1	0.98067	98066.5	98.0665	14.2233	2048.16
bar	1.01972	1	100000	100	14.5037	2088.6
Pa=N / m ²	0.00001	0.001	1	0.001	0.00015	0.02086
kPa	0.01020	0.01	1000	1	0.14504	20.886
lbf / in ²	0.07032	0.0689	6894.76	6.89476	1	144
lbf / ft ²	0.00047	0.00047	47.88028	0.04788	0.00694	1
1 kgf / cm ² = 735.56 Torr (mmHg) = 0.96784 atm						

Approximate conversions

SI Unit	Conversion Factor	Non-SI Unit	Conversion Factor	SI Unit
Torque				
newton meter (N·m)	x 10.2	= kgf·cm	x 0.8664	= (lbf·in)
newton meter (N·m)	x 0.74	= lb·ft	x 1.36	= N·m
newton meter (N·m)	x 0.102	= kgf·m	x 7.22	= (lbf·ft)
Pressure (Pa = N / m²)				
kilopascal (kPa)	x 4.0	= in. H ₂ O	x 0.249	= kPa
kilopascal (kPa)	x 0.30	= in. Hg	x 3.38	= kPa
kilopascal (kPa)	x 0.145	= psi	x 6.89	= kPa
(bar)	x 14.5	= psi	x 0.069	= (bar)
(kgf / cm ²)	x 14.22	= psi	x 0.070	= (kgf / cm ²)
(newton / mm ²)	x 145.04	= psi	x 0.069	= (bar)
megapascal (MPa)	x 145	= psi	x 0.00689	= MPa
Power (W = J / s)				
kilowatt (kW)	x 1.36	= PS (cv)	x 0.736	= kW
kilowatt (kW)	x 1.34	= HP	x 0.746	= kW
kilowatt (kW)	x 0.948	= Btu / s	x 1.055	= kW
watt (W)	x 0.74	= ft·lb / s	x 1.36	= W
Energy (J = N·m)				
kilojoule (kJ)	x 0.948	= Btu	x 1.055	= kJ
joule (J)	x 0.239	= calorie	x 4.19	= J
Velocity and Acceleration				
meter per sec ² (m / s ²)	x 3.28	= ft / s ²	x 0.305	= m / s ²
meter per sec (m / s)	x 3.28	= ft / s	x 0.305	= m / s
kilometer per hour (km / h)	x 0.62	= mph	x 1.61	= km / h
Horse power /torque				
BHP x 5252 rpm = TQ (lb·ft)			TQ x rpm 5252 = B.H.P.	
Temperature				
°C = (°F - 32) / 1.8		°F = (°C x 1.8) + 32		
Flow Rate				
liter / min (dm ³ / min)	x 0.264	= US gal / min x 3.785	= liter / min	

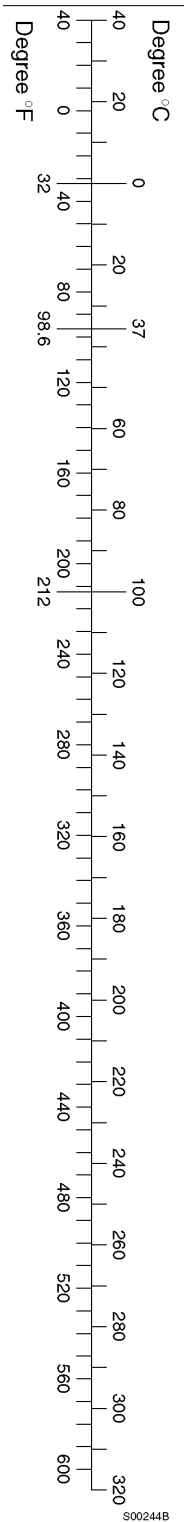

S00244B

Note : () non-si unit

Document Title: Specifications, general	Function Group: 030	Information Type: Service Information	Date: 11/26/2025
Profile:			

Specifications, general

General specification

Item		Unit	Specifications
Operating weight		kg	27800
		lb	61300
Ground contact pressure		kgf / cm ²	0.53
		psi	7.54
Slew speed	Steady	rpm	10.8
Travel speed	1 speed	km / h	3.3
		mph	2.05
	2 speed	km / h	5.2
		mph	3.23
Maximum digging force (Normal / Pressurized)		kg	16100/17600
		lb	35480/38801
Maximum tractive effort		ton	23.5
Gradeability		%	70
		deg	35

Document Title: Specifications, general	Function Group: 030	Information Type: Service Information	Date: 11/26/2025
Profile:			

Specifications, general

General specification

Item		Unit	Specifications
Operating weight		kg	27800
		lb	61300
Ground contact pressure		kgf / cm ²	0.53
		psi	7.54
Slew speed	Steady	rpm	10.8
Travel speed	1 speed	km / h	3.3
		mph	2.05
	2 speed	km / h	5.2
		mph	3.23
Maximum digging force (Normal / Pressurized)		kg	16100/17600
		lb	35480/38801
Maximum tractive effort		ton	23.5
Gradeability		%	70
		deg	35

Document Title: Specifications, general	Function Group: 030	Information Type: Service Information	Date: 11/26/2025
Profile:			

Specifications, general

General specification



Item		Unit	Specifications
Operating weight		kg	27800
		lb	61300
Ground contact pressure		kgf / cm ²	0.53
		psi	7.54
Slew speed	Steady	rpm	10.8
Travel speed	1 speed	km / h	3.3
		mph	2.05
	2 speed	km / h	5.2
		mph	3.23
Maximum digging force (Normal / Pressurized)		kg	16100/17600
		lb	35480/38801
Maximum tractive effort		ton	23.5
Gradeability		%	70
		deg	35

Document Title: Standard tightening torque	Function Group: 030	Information Type: Service Information	Date: 11/26/2025
Profile:			

Standard tightening torque

The following charts give the standard tightening torques of screws and nuts. Exceptions are given in each sections of "disassembly and assembly".

Tightening torque (meter)

Classification	4T, 5T	10T
Screw type		
Screw size	Torque kgf·m (lbf·ft)	Torque kgf·m (lbf·ft)
M4	0.2 ± 0.02 (1.4 ± 0.1)	0.4 ± 0.04 (2.9 ± 0.3)
M5	0.3 ± 0.03 (2.2 ± 0.2)	0.8 ± 0.08 (5.8 ± 0.6)
M6	0.5 ± 0.05 (3.6 ± 0.4)	1.4 ± 0.14 (10.1 ± 1.0)
M8	1.2 ± 0.12 (8.7 ± 0.9)	3.3 ± 0.3 (23.8 ± 2.2)
M10	2.3 ± 0.23 (16.6 ± 1.7)	6.5 ± 0.7 (47 ± 5)
M12	4.0 ± 0.4 (29 ± 3)	11.3 ± 1.1 (82 ± 8)
<M14>	6.4 ± 0.6 (46 ± 4)	17.9 ± 1.8 (129 ± 13)
M16	9.5 ± 0.9 (69 ± 6)	26.7 ± 2.7 (193 ± 19)
<M18>	13.5 ± 1.4 (97 ± 10)	38.0 ± 3.8 (274 ± 27)
M20	18.6 ± 1.9 (134 ± 14)	52.2 ± 5.2 (377 ± 38)
<M22>	24.7 ± 2.5 (178 ± 18)	69.4 ± 6.9 (500 ± 50)
M24	32.1 ± 3.2 (232 ± 23)	90.2 ± 9.0 (650 ± 65)
M30	62.6 ± 6.3 (452 ± 45)	176.1 ± 17.6 (1270 ± 127)
M36	108.2 ± 10.8 (781 ± 78)	304.3 ± 30.4 (2200 ± 220)
M42	171.8 ± 17.2 (1240 ± 124)	483.2 ± 48.3 (3500 ± 350)
M45	211.3 ± 21.1 (1525 ± 152)	594.3 ± 50.4 (4300 ± 430)

Tightening torque (inch)

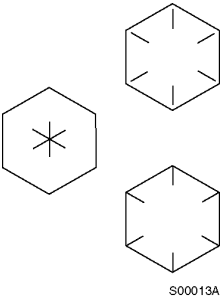
Classification	4T, 5T	10T
Screw type		
Screw size	Torque kgf·m (lbf·ft)	Torque kgf·m (lbf·ft)
1/4	0.6 ± 0.06 (4.3 ± 0.4)	1.7 ± 0.2 (12.2 ± 1.2)
5/16	1.2 ± 0.12 (8.7 ± 0.8)	3.0 ± 0.3 (21.7 ± 2.2)
3/8	2.0 ± 0.20 (14.4 ± 1.4)	5.6 ± 0.5 (40 ± 4)
7/16	3.2 ± 0.32 (23 ± 2)	8.9 ± 0.9 (64 ± 6)
1/2	4.7 ± 0.47 (34 ± 3)	13.4 ± 1.3 (97 ± 10)
9/16	6.8 ± 0.68 (50 ± 5)	19.0 ± 1.9 (137 ± 14)
5/8	9.3 ± 0.93 (67 ± 7)	26.1 ± 2.6 (190 ± 19)
3/4	16.0 ± 1.60 (115 ± 15)	45.1 ± 4.5 (325 ± 33)
7/8	25.5 ± 2.55 (185 ± 19)	71.6 ± 7.2 (520 ± 52)

1	38.0 ± 3.80 (275 ± 27)	106.9 ± 10.7 (770 ± 77)
1-1/8	54.1 ± 5.41 (390 ± 39)	152.2 ± 15.2 (1100 ± 110)
1-1/4	74.2 ± 7.42 (535 ± 54)	208.9 ± 20.9 (1510 ± 151)
1-3/4	98.8 ± 9.88 (710 ± 71)	277.8 ± 27.8 (2000 ± 200)
1-1/2	128.2 ± 12.82 (925 ± 93)	360.7 ± 36.1 (2600 ± 260)

NOTE!

This torque table does not apply to screws with nylon packings or where nonferrous metal washers are to be used, or which require tightening to a different specified torque, or tightening procedure.

NOTE!

N·m (Newton meter) : 1 N·m ≅ 0.1 kgf·m

Tightening torque of split flange screws

Use these torques for split flange screws.

Tightening torque (split flange screws)

Thread diameter of screw (mm)	Width across flats (mm)	Tightening torque	
		kgf·m (lbf·ft)	N·m
10	14	6.7 ± 0.7 (48.4 ± 5)	65.7 ± 6.8
12	17	11.5 ± 1 (83 ± 8)	112 ± 9.8
16	22	28.5 ± 3 (206 ± 20)	279 ± 29

Tightening torque for hydraulic plugs with o-ring

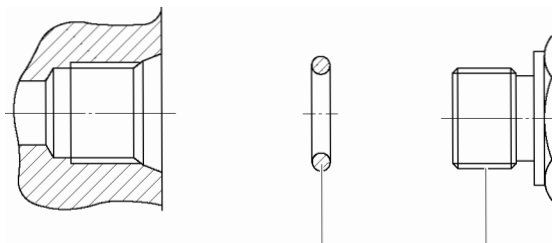

Figure 1

Hydraulic plugs with o-ring

1. O-ring
2. Plug

Pf thread

Tightening torque (hydraulic plugs)

Thread	Plug part No.	Tightening torque kgf·m (lbf·ft)
1 / 8	9415-11012	2.5 ± 0.2 (18 ± 1.4)
1 / 4	9415-11022	5.0 ± 0.5 (36 ± 3.6)
3 / 8	9415-11032	7.5 ± 0.5 (54 ± 3.6)
1 / 2	9415-11042	11.0 ± 1.0 (79 ± 7)
3 / 4	9415-11052	18.0 ± 1.0 (130 ± 7)
1	9415-11062	21.0 ± 2.0 (152 ± 14)

Tightening torque for swivel nut fitting with o-ring

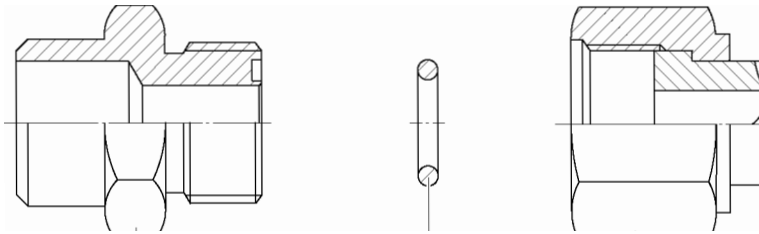

Figure 2
Swivel nut fitting with o-ring

1. Connector
2. O-ring
3. Swivel nut
4. Hose

Tightening torque for swivel nut fitting



Tube outer diameter (in)	Thread size (in)	Tightening torque, kgf·m (lbf·ft)
1/2	UN 13/16 – 16	9.5 ± 0.95 (69 ± 7)
3/4	UN 1 3/16 – 12	18 ± 1.8 (130 ± 13)
1	UN 1 7/16 – 12	21 ± 2.1 (152 ± 15)

Document Title: Standard tightening torque	Function Group: 030	Information Type: Service Information	Date: 11/26/2025
Profile:			

Standard tightening torque

The following charts give the standard tightening torques of screws and nuts. Exceptions are given in each sections of "disassembly and assembly".

Tightening torque (meter)

Classification	4T, 5T	10T
Screw type		
Screw size	Torque kgf·m (lbf·ft)	Torque kgf·m (lbf·ft)
M4	0.2 ± 0.02 (1.4 ± 0.1)	0.4 ± 0.04 (2.9 ± 0.3)
M5	0.3 ± 0.03 (2.2 ± 0.2)	0.8 ± 0.08 (5.8 ± 0.6)
M6	0.5 ± 0.05 (3.6 ± 0.4)	1.4 ± 0.14 (10.1 ± 1.0)
M8	1.2 ± 0.12 (8.7 ± 0.9)	3.3 ± 0.3 (23.8 ± 2.2)
M10	2.3 ± 0.23 (16.6 ± 1.7)	6.5 ± 0.7 (47 ± 5)
M12	4.0 ± 0.4 (29 ± 3)	11.3 ± 1.1 (82 ± 8)
<M14>	6.4 ± 0.6 (46 ± 4)	17.9 ± 1.8 (129 ± 13)
M16	9.5 ± 0.9 (69 ± 6)	26.7 ± 2.7 (193 ± 19)
<M18>	13.5 ± 1.4 (97 ± 10)	38.0 ± 3.8 (274 ± 27)
M20	18.6 ± 1.9 (134 ± 14)	52.2 ± 5.2 (377 ± 38)
<M22>	24.7 ± 2.5 (178 ± 18)	69.4 ± 6.9 (500 ± 50)
M24	32.1 ± 3.2 (232 ± 23)	90.2 ± 9.0 (650 ± 65)
M30	62.6 ± 6.3 (452 ± 45)	176.1 ± 17.6 (1270 ± 127)
M36	108.2 ± 10.8 (781 ± 78)	304.3 ± 30.4 (2200 ± 220)
M42	171.8 ± 17.2 (1240 ± 124)	483.2 ± 48.3 (3500 ± 350)
M45	211.3 ± 21.1 (1525 ± 152)	594.3 ± 50.4 (4300 ± 430)

Tightening torque (inch)

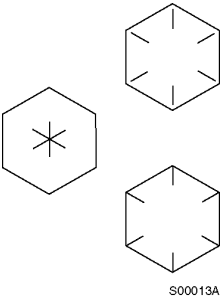
Classification	4T, 5T	10T
Screw type		
Screw size	Torque kgf·m (lbf·ft)	Torque kgf·m (lbf·ft)
1/4	0.6 ± 0.06 (4.3 ± 0.4)	1.7 ± 0.2 (12.2 ± 1.2)
5/16	1.2 ± 0.12 (8.7 ± 0.8)	3.0 ± 0.3 (21.7 ± 2.2)
3/8	2.0 ± 0.20 (14.4 ± 1.4)	5.6 ± 0.5 (40 ± 4)
7/16	3.2 ± 0.32 (23 ± 2)	8.9 ± 0.9 (64 ± 6)
1/2	4.7 ± 0.47 (34 ± 3)	13.4 ± 1.3 (97 ± 10)
9/16	6.8 ± 0.68 (50 ± 5)	19.0 ± 1.9 (137 ± 14)
5/8	9.3 ± 0.93 (67 ± 7)	26.1 ± 2.6 (190 ± 19)
3/4	16.0 ± 1.60 (115 ± 15)	45.1 ± 4.5 (325 ± 33)
7/8	25.5 ± 2.55 (185 ± 19)	71.6 ± 7.2 (520 ± 52)

1	38.0 ± 3.80 (275 ± 27)	106.9 ± 10.7 (770 ± 77)
1-1/8	54.1 ± 5.41 (390 ± 39)	152.2 ± 15.2 (1100 ± 110)
1-1/4	74.2 ± 7.42 (535 ± 54)	208.9 ± 20.9 (1510 ± 151)
1-3/4	98.8 ± 9.88 (710 ± 71)	277.8 ± 27.8 (2000 ± 200)
1-1/2	128.2 ± 12.82 (925 ± 93)	360.7 ± 36.1 (2600 ± 260)

NOTE!

This torque table does not apply to screws with nylon packings or where nonferrous metal washers are to be used, or which require tightening to a different specified torque, or tightening procedure.

NOTE!

N·m (Newton meter) : 1 N·m ≅ 0.1 kgf·m

Tightening torque of split flange screws

Use these torques for split flange screws.

Tightening torque (split flange screws)

Thread diameter of screw (mm)	Width across flats (mm)	Tightening torque	
		kgf·m (lbf·ft)	N·m
10	14	6.7 ± 0.7 (48.4 ± 5)	65.7 ± 6.8
12	17	11.5 ± 1 (83 ± 8)	112 ± 9.8
16	22	28.5 ± 3 (206 ± 20)	279 ± 29

Tightening torque for hydraulic plugs with o-ring

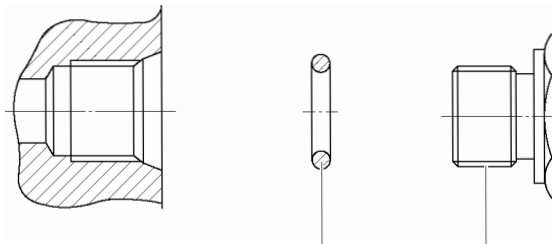

Figure 1

Hydraulic plugs with o-ring

1. O-ring
2. Plug

Pf thread

Tightening torque (hydraulic plugs)

Thread	Plug part No.	Tightening torque kgf·m (lbf·ft)
1 / 8	9415-11012	2.5 ± 0.2 (18 ± 1.4)
1 / 4	9415-11022	5.0 ± 0.5 (36 ± 3.6)
3 / 8	9415-11032	7.5 ± 0.5 (54 ± 3.6)
1 / 2	9415-11042	11.0 ± 1.0 (79 ± 7)
3 / 4	9415-11052	18.0 ± 1.0 (130 ± 7)
1	9415-11062	21.0 ± 2.0 (152 ± 14)

Tightening torque for swivel nut fitting with o-ring

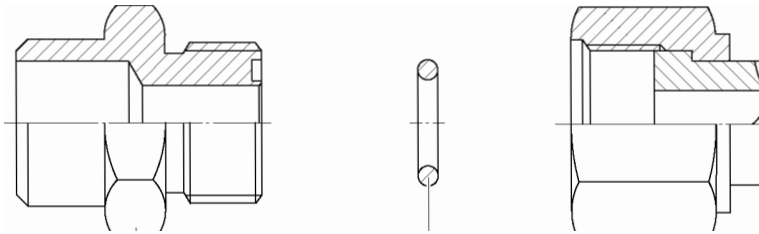

Figure 2
Swivel nut fitting with o-ring

- 1. Connector
- 2. O-ring
- 3. Swivel nut
- 4. Hose

Tightening torque for swivel nut fitting



Tube outer diameter (in)	Thread size (in)	Tightening torque, kgf·m (lbf·ft)
1/2	UN 13/16 – 16	9.5 ± 0.95 (69 ± 7)
3/4	UN 1 3/16 – 12	18 ± 1.8 (130 ± 13)
1	UN 1 7/16 – 12	21 ± 2.1 (152 ± 15)

Document Title: Standard tightening torque	Function Group: 030	Information Type: Service Information	Date: 11/26/2025
Profile:			

Standard tightening torque

The following charts give the standard tightening torques of screws and nuts. Exceptions are given in each sections of "disassembly and assembly".

Tightening torque (meter)

Classification	4T, 5T	10T
Screw type		
Screw size	Torque kgf·m (lbf·ft)	Torque kgf·m (lbf·ft)
M4	0.2 ± 0.02 (1.4 ± 0.1)	0.4 ± 0.04 (2.9 ± 0.3)
M5	0.3 ± 0.03 (2.2 ± 0.2)	0.8 ± 0.08 (5.8 ± 0.6)
M6	0.5 ± 0.05 (3.6 ± 0.4)	1.4 ± 0.14 (10.1 ± 1.0)
M8	1.2 ± 0.12 (8.7 ± 0.9)	3.3 ± 0.3 (23.8 ± 2.2)
M10	2.3 ± 0.23 (16.6 ± 1.7)	6.5 ± 0.7 (47 ± 5)
M12	4.0 ± 0.4 (29 ± 3)	11.3 ± 1.1 (82 ± 8)
<M14>	6.4 ± 0.6 (46 ± 4)	17.9 ± 1.8 (129 ± 13)
M16	9.5 ± 0.9 (69 ± 6)	26.7 ± 2.7 (193 ± 19)
<M18>	13.5 ± 1.4 (97 ± 10)	38.0 ± 3.8 (274 ± 27)
M20	18.6 ± 1.9 (134 ± 14)	52.2 ± 5.2 (377 ± 38)
<M22>	24.7 ± 2.5 (178 ± 18)	69.4 ± 6.9 (500 ± 50)
M24	32.1 ± 3.2 (232 ± 23)	90.2 ± 9.0 (650 ± 65)
M30	62.6 ± 6.3 (452 ± 45)	176.1 ± 17.6 (1270 ± 127)
M36	108.2 ± 10.8 (781 ± 78)	304.3 ± 30.4 (2200 ± 220)
M42	171.8 ± 17.2 (1240 ± 124)	483.2 ± 48.3 (3500 ± 350)
M45	211.3 ± 21.1 (1525 ± 152)	594.3 ± 50.4 (4300 ± 430)

Tightening torque (inch)

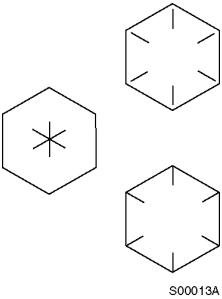
Classification	4T, 5T	10T
Screw type		
Screw size	Torque kgf·m (lbf·ft)	Torque kgf·m (lbf·ft)
1/4	0.6 ± 0.06 (4.3 ± 0.4)	1.7 ± 0.2 (12.2 ± 1.2)
5/16	1.2 ± 0.12 (8.7 ± 0.8)	3.0 ± 0.3 (21.7 ± 2.2)
3/8	2.0 ± 0.20 (14.4 ± 1.4)	5.6 ± 0.5 (40 ± 4)
7/16	3.2 ± 0.32 (23 ± 2)	8.9 ± 0.9 (64 ± 6)
1/2	4.7 ± 0.47 (34 ± 3)	13.4 ± 1.3 (97 ± 10)
9/16	6.8 ± 0.68 (50 ± 5)	19.0 ± 1.9 (137 ± 14)
5/8	9.3 ± 0.93 (67 ± 7)	26.1 ± 2.6 (190 ± 19)
3/4	16.0 ± 1.60 (115 ± 15)	45.1 ± 4.5 (325 ± 33)
7/8	25.5 ± 2.55 (185 ± 19)	71.6 ± 7.2 (520 ± 52)

1	38.0 ± 3.80 (275 ± 27)	106.9 ± 10.7 (770 ± 77)
1-1/8	54.1 ± 5.41 (390 ± 39)	152.2 ± 15.2 (1100 ± 110)
1-1/4	74.2 ± 7.42 (535 ± 54)	208.9 ± 20.9 (1510 ± 151)
1-3/4	98.8 ± 9.88 (710 ± 71)	277.8 ± 27.8 (2000 ± 200)
1-1/2	128.2 ± 12.82 (925 ± 93)	360.7 ± 36.1 (2600 ± 260)

NOTE!

This torque table does not apply to screws with nylon packings or where nonferrous metal washers are to be used, or which require tightening to a different specified torque, or tightening procedure.

NOTE!

N·m (Newton meter) : 1 N·m ≅ 0.1 kgf·m

Tightening torque of split flange screws

Use these torques for split flange screws.

Tightening torque (split flange screws)

Thread diameter of screw (mm)	Width across flats (mm)	Tightening torque	
		kgf·m (lbf·ft)	N·m
10	14	6.7 ± 0.7 (48.4 ± 5)	65.7 ± 6.8
12	17	11.5 ± 1 (83 ± 8)	112 ± 9.8
16	22	28.5 ± 3 (206 ± 20)	279 ± 29

Tightening torque for hydraulic plugs with o-ring

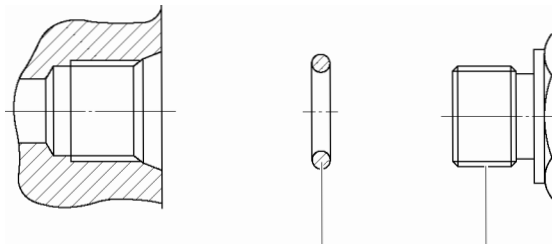

Figure 1

Hydraulic plugs with o-ring

1. O-ring
2. Plug

Pf thread

Tightening torque (hydraulic plugs)

Thread	Plug part No.	Tightening torque kgf·m (lbf·ft)
1 / 8	9415-11012	2.5 ± 0.2 (18 ± 1.4)
1 / 4	9415-11022	5.0 ± 0.5 (36 ± 3.6)
3 / 8	9415-11032	7.5 ± 0.5 (54 ± 3.6)
1 / 2	9415-11042	11.0 ± 1.0 (79 ± 7)
3 / 4	9415-11052	18.0 ± 1.0 (130 ± 7)
1	9415-11062	21.0 ± 2.0 (152 ± 14)

Tightening torque for swivel nut fitting with o-ring

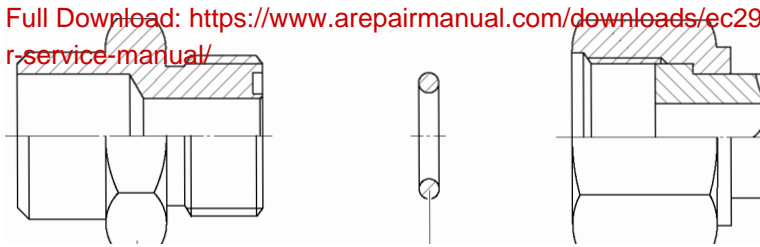

Figure 2

Swivel nut fitting with o-ring

1. Connector
2. O-ring
3. Swivel nut
4. Hose

Tightening torque for swivel nut fitting

Tube outer diameter (in)	Thread size (in)	Tightening torque, kgf·m (lbf·ft)
1/2	UN 13/16 – 16	9.5 ± 0.95 (69 ± 7)
3/4	UN 1 3/16 – 12	18 ± 1.8 (130 ± 13)
1	UN 1 7/16 – 12	21 ± 2.1 (152 ± 15)