

Document Title: <b>Machine view</b>	Function Group: <b>000</b>	Information Type: <b>Service Information</b>	Date: <b>9/9/2025</b>
Profile: <b>EC210F 3</b>			

## Machine view

Showing Selected Profile

Valid for serial numbers			
Model	Production site	Serial number start	Serial number stop
EC210F 3			

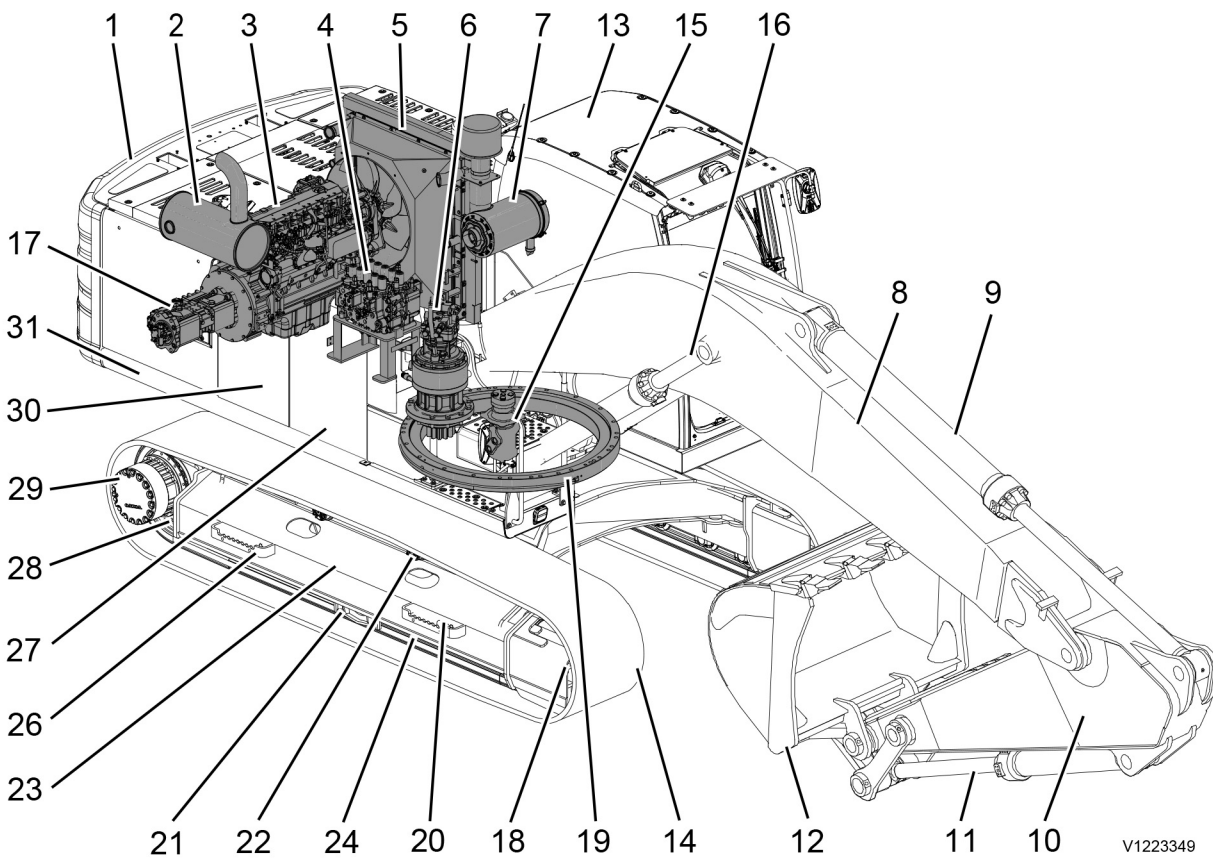

V1223349

**Figure 1**

1	Counterweight	16	Boom cylinder
2	Muffler	17	Hydraulic pump
3	Engine	18	Idler
4	Main control valve	19	Swing ring gear
5	Radiator and charge air cooler	20	Track tension grease valve
6	Swing motor and gearbox	21	Track guard
7	Air cleaner	22	Top roller
8	Boom	23	Lower frame
9	Dipper arm cylinder	24	Bottom roller

Product: Volvo EC210F 3 Excavators Service Manual

Full Download: <https://www.arepairmanual.com/downloads/volvo-ec210f-3-excavators-service-manual/>

10	Dipper arm	26	Steps
11	Bucket cylinder	27	Fuel tank
12	Bucket	28	Sprocket
13	Operator's cab	29	Track motor and gearbox
14	Track chain	30	Hydraulic tank
15	Turning joint	31	Upper frame

Sample of manual. Download All 2165 pages at:

<https://www.arepairmanual.com/downloads/volvo-ec210f-3-excavators-service-manual/>

Document Title: <b>Product plates</b>	Function Group: <b>000</b>	Information Type: <b>Service Information</b>	Date: <b>9/9/2025</b>
Profile: <b>EC210F 3</b>			

## Product plates

Showing Selected Profile

Valid for serial numbers			
Model	Production site	Serial number start	Serial number stop
EC210F 3			

Please refer to the figure below to locate the product plate, engine plate, cab plate and attachment plates. Always use the Product Identification Number (PIN) provided on the vehicle and/or engine plates for troubleshooting purposes and/or when ordering spare parts.

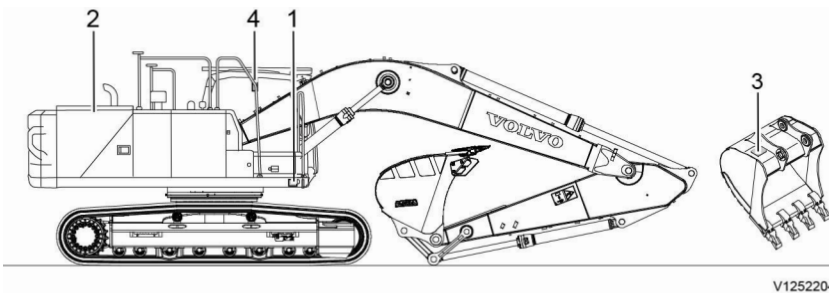

**Figure 1**

### 1. Product plate

This plate with Product Identification Number, PIN, for the complete machine indicates the model designation, serial number and when applicable, machine weight, engine power, manufacturing year and CE approval. The plate is positioned on the right side of the superstructure.

#### Models (General application)

Volvo Crawler excavators and Wheel Excavator are available in different sizes from 5 ton to 95 ton. Some machines can be equipped with different Attachments, Demolition, High Reach Demolition, Pipe Layer, Rotating Pipelayer Kit machine and Dozer blade.

AG	Agricultural machines	LS	Long Crawler Shanghai
EC	Excavator Crawler	LD, LCD	Long Crawler Demolition
EW	Excavator Wheel	LC4	Long Crawler 4
ECR	Excavator Crawler Short-Swing-Radius	LHDS	Long Crawler Heavy Duty Shanghai
F, FX	Forestry Application	LHDC	Long Crawler Heavy Duty Changwon
FE	Feller Bunchers	LRC4	Long Reach Crawler 4 (Boom & Arm)
F3 FL3 FLR3	Low regulated	N, NC	Narrow Crawler
FL5 FLR5	High regulated	NL, NLC	Narrow Long Crawler
HR	High Reach Demolition	NLD	Narrow Crawler Demolition
L, LC	Long Crawler	NH	Narrow Heavy Duty

LM, LCM	Long Crawler Marsh	PL	Pipe Layer
LR	Long Reach Boom & Arm		

### Supplementary PIN plate (EU countries only)

V	C	E	E	3	5	C	C	0	0	0	1	2	3	4	5
A		B			C		D								

V1076896

**Figure 2**

Example of 17 digit PIN number on PIN plate

- A. World Manufacturing Code
- B. Machine description
- C. Check letters
- D. Serial number

The supplementary plate contains information about machine mass in kg, engine net power in Kw, manufacturing year, machine serial number and a CE-mark.

#### Machine mass

The machine mass in kg on the supplementary PIN plate is based on:

- cab or canopy
- most used track type
- most usual bucket (without load)
- full fuel tank

For safety reasons, 103 % of the machine mass will be shown on the supplementary PIN plate.

#### 2. Engine

The engine type designation, part and serial numbers are stamped on the top of valve cover.

#### 3. Bucket

This nameplate is attached on the top of the bucket and indicates the bucket model order number, serial number, supplier code, rated capacity, weight, cutting width, tooth part number and adapter part number.

#### 4. Cab

The nameplate is attached on the inside of the cab and indicates the product number, serial number, model type, and weight.

Document Title: <b>Volvo standard tightening torques</b>	Function Group: <b>030</b>	Information Type: <b>Service Information</b>	Date: <b>9/9/2025</b>
Profile: <b>EC210F 3</b>			

## Volvo standard tightening torques

Showing Selected Profile

Valid for serial numbers			
Model	Production site	Serial number start	Serial number stop
EC210F 3			

The tightening torques in the following tables apply to bolts and nuts with tensile strength. The tables should be used as a general instruction for tightening bolts and nuts without specified values. The charts contains values for course thread bolts and nuts.

Torque values should be increased with  $\approx 10\%$ , for flange bolts.

All standard torques for bolts are without surface treatment.

The standard torque for bolts lubricated with oil should be reduced with 20% of the given value.

### Standard tightening torque charts

Bolt size Metric Coarse Threads	Tensile strength 8.8		Tensile strength 10.9	
	(Nm)	(lbf ft)	(Nm)	(lbf ft)
M5	6	4	8	6
M6	10	7	14	11
M8	25	18	35	26
M10	50	37	70	52
M12	87	64	122	90
M14	139	103	195	144
M16	213	157	299	220
M18	293	216	413	305
M20	416	307	585	432
M24	719	530	1010	745
M27	1060	782	1490	1100
M30	1140	840	2025	1493
M36	2500	1844	3600	2653

Bolt size Inch SAE Coarse Threads	Tensile strength 5		Tensile strength 8	
	(lbf ft)	(Nm)	(lbf ft)	(Nm)
1/4	10	13,6	14	19
5/16	21	28,5	29	39,3
3/8	37	50,2	52	70
7/16	59	80	84	114
1/2	90	122	128	174
9/16	130	176	184	250
5/8	180	244	254	345

3/4	320	434	451	612
7/8	515	700	728	988
1	775	1052	1091	1480
1 1/8	953	1290	1545	2100
1 1/4	1344	1823	2180	2960
1 3/8	1600	2170	2650	3600
1 1/2	2000	2714	3200	4340

### Hydraulic connections, general

Before fitting pipe couplings, plugs and hoses:

- Make sure that the sealing surfaces are clean and free from pores or scratches.
- Check elastic seal rings for defects.
- Oil in threads, sealing surfaces and contact surfaces except for ORFS-connections (ORFS = O-Ring Face Seal).

### Applying Torque correction factor by tool angle

Tool angle	Correction factor	
	ORFS	Stud-end
Allowable tolerance	±10%	- 0%, +10%
±0° ~ ±30°	5% over torque	
±30° ~ ±45°	20% over torque	
±45°	NOT allowable	

### Tool access angle

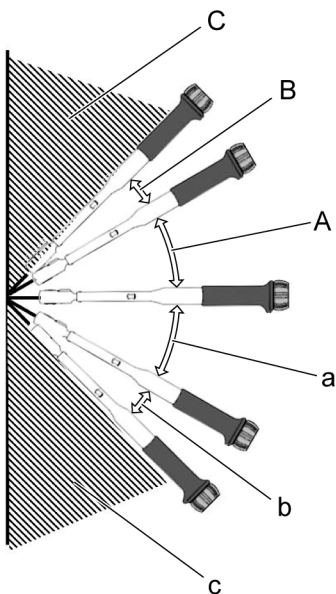

V1223202

**Figure 1**

Tool access angle

A: +0° ~ +30°

B: +30° ~ +45°

C: +45°

a: -0° ~ -30°

b: -30° ~ -45°

c: -45°

**ORFS female swivel fitting**

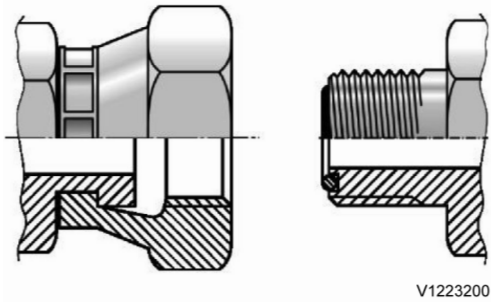
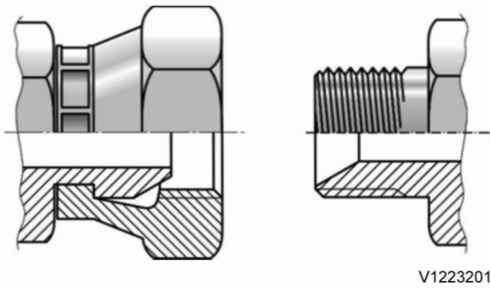

**Figure 2**

Thread s type	Assembl y position	Threads	Standard torque		±0° ~ ±30°		±30° ~ ±45°	
			(Nm)	(lbf ft)	(Nm)	(lbf ft)	(Nm)	(lbf ft)
UN- UNF	ORFS	UNF 9/16-18	29 ±3	21.4 ±2.2	30.5 ±3.1	22.1 ±2.2	36.5 ±3.7	26.9 ±2.7
		UN 11/16-16	44 ±4	32.5 ±3.0	46.2 ±4.6	34.1 ±3.4	55.4 ±5.5	40.9 ±4.1
		UN 13/16-16	63 ±6	46.5 ±4.4	66.2 ±6.6	48.8 ±4.9	79.4 ±7.9	58.6 ±5.9
		UNS 1-14	106 ±8	78.2 ±5.9	111.3 ±11.1	82.1 ±8.2	133.6 ±13.4	98.5 ±9.9
		UN 1 3/16-12	140 ±12	103.3 ±8.9	147.0 ±14.7	108.4 ±10.8	176.4 ±17.6	130.1 ±13.0
		UN 1 7/16-12	175 ±15	129.1 ±11.1	183.8 ±18.4	135.6 ±13.6	220.5 ±22.1	162.6 ±16.3
		UN 1 11/16-12	270 ±20	199.1 ±14.8	283.5 ±28.4	209.1 ±20.9	340.2 ±34.0	250.9 ±25.1
	Stud-end	UNF 7/16-20	21 +2.1	15.4 +1.5	22.1 +2.2	16.3 +1.6	26.5 +2.7	19.5 +2.0
		UNF 1/2-20	37 +3.7	27.3 +2.7	38.9 +3.9	28.7 +2.9	46.6 +4.7	34.4 +3.4
		UNF 9/16-18	47 +4.7	34.7 +3.5	49.4 +4.9	36.4 +3.6	59.2 +5.9	43.7 +4.4
		UNF 3/4-16	81 +8.1	59.7 +6.0	85.1 +8.5	62.8 +6.3	102.1 +10.2	75.3 +7.5
		UNF 7/8-14	141 +14.1	104.0 +10.4	148.1 +14.8	109.2 +10.9	177.7 +17.8	131.1 +13.1
		UN 1 1/16-12	189 +18.9	139.4 +13.9	198.5 +19.9	146.4 +14.6	238.1 +23.8	175.6 +17.6
		UN 1 5/16-12	284 +28.4	209.5 +21.0	298.2 +29.8	219.9 +22.0	357.8 +35.8	263.9 +26.4
UN 1 5/8-12	347 +34.7	255.9 +25.6	364.4 +36.4	268.8 +26.9	437.2 43.7	322.5 +32.3		

UN 1 7/8-12	425 +42.5	313.5 +31.4	446.3 +44.6	329.2 +32.9	535.5 +53.6	395.0 +39.5
----------------	-----------	-------------	-------------	-------------	-------------	-------------

**G thread 30° cone female swivel fitting**



**Figure 3**

Thread s type	Assembl y position	Threads	Standard torque		±0° ~ ±30°		±30° ~ ±45°	
			(Nm)	(lbf ft)	(Nm)	(lbf ft)	(Nm)	(lbf ft)
PF	ORFS	G 1/4-19	25 ±2.5	18.4 ±1.8	26.3 ± 2.6	19.4 ±1.9	31.5 ±3.2	23.2 ±2.3
		G 3/8-19	49 ±4.9	36.1 ±3.6	51.5 ± 5.2	38.0 ±3.8	61.7 ±6.2	45.5 ±4.6
		G 1/2-14	59 ±5.9	43.5 ±4.4	62.0 ± 6.2	45.7 ±4.6	74.3 ±7.4	54.8 ±5.5
		G 3/4-11	119 ±11.9	87.8 ±8.8	125.0 ±12.5	92.2 ±9.2	149.9 ±15.0	110.6 ±11.1
		G 1-11	140 ±14	103.3 ±10.3	147.0 ±14.7	108.4 ±10.8	176.4 ±17.6	130.1 ±13.0
		G 1 1/4-11	173 ±17.3	127.6 ±12.8	181.7 ±18.2	134.0 ±13.4	218.0 ±21.8	160.8 ±16.1
		G 1 1/2-11	205 ±20.5	151.2 ±15.1	215.3 ±21.5	158.8 ±15.9	258.3 ±25.8	190.5 ±19.1
	Stud-end	G 1/8-19	22 +2.2	16.2 +1.6	23.1 +2.3	17.0 +1.7	27.7 +2.8	20.4 +2.0
		G 1/4-19	52 +5.2	38.4 +3.8	54.6 +5.5	40.3 +4.0	65.5 +6.6	48.3 +4.8
		G 3/8-19	85 +8.5	62.7 +6.3	89.3 +8.9	65.9 +6.6	107.1 +10.7	79.0 +7.9
		G 1/2-14	105 +10.5	77.4 +7.7	110.3 +11.0	81.4 +8.1	132.3 +13.2	97.6 +9.8
		G 3/4-11	210 +21	154.9 +15.5	220.5 +22.1	162.6 +16.3	264.6 +26.5	195.2 +19.5
		G 1-11	400 +40	295.0 +29.5	420.0 +42.0	309.8 +31.0	504.0 +50.4	371.7 +37.1
		G 1 1/4-11	525 +52.5	387.2 +38.7	551.3 +55.1	406.6 +40.7	661.5 +66.2	487.9 +48.8
G 1 1/2-11	630 +63.1	464.7 +46.5	661.5 +66.2	487.9 +48.8	793.8 +79.4	585.5 +58.6		

Document Title: <b>Measurement conversion tables</b>	Function Group: <b>030</b>	Information Type: <b>Service Information</b>	Date: <b>9/9/2025</b>
Profile: <b>EC210F 3</b>			

## Measurement conversion tables

Showing Selected Profile

Valid for serial numbers			
Model	Production site	Serial number start	Serial number stop
EC210F 3			

### Length

Unit	cm	m	km	in	ft	yd	mile
cm	1	0.01	0.00001	0.3937	0.03281	0.01094	0.000006
m	100	1	0.001	39.37	3.2808	1.0936	0.00062
km	100000	1000	1	39370.7	3280.8	1093.6	0.62137
in	2.54	0.0254	0.000025	1	0.08333	0.02777	0.000015
ft	30.48	0.3048	0.000304	12	1	0.3333	0.000189
yd	91.44	0.9144	0.000914	36	3	1	0.000568
mile	160930	1609.3	1.6093	63360	5280	1760	1

1 mm = 0.1 cm, 1 mm = 0.001 m

### Area

Unit	cm <sup>2</sup>	m <sup>2</sup>	km <sup>2</sup>	a	ft <sup>2</sup>	yd <sup>2</sup>	in <sup>2</sup>
cm <sup>2</sup>	1	0.0001	-	0.000001	0.001076	0.000012	0.155000
m <sup>2</sup>	10000	1	0.000001	0.01	10.764	1.1958	1550.000
km <sup>2</sup>	-	1000000	1	10000	1076400	1195800	-
a	0.01	100	0.0001	1	1076.4	119.58	-
ft <sup>2</sup>	-	0.092903	-	0.000929	1	0.1111	144.000
yd <sup>2</sup>	-	0.83613	-	0.008361	9	1	1296.00
in <sup>2</sup>	6.4516	0.000645	-	-	0.006943	0.000771	1

1 ha = 100 a, 1 mile<sup>2</sup> = 259 ha = 2.59 km<sup>2</sup>

### Volume

Unit	cm <sup>3</sup> = cc	m <sup>3</sup>	Liter	in <sup>3</sup>	ft <sup>3</sup>	yd <sup>3</sup>
cm <sup>3</sup> = m liter	1	0.000001	0.001	0.061024	0.000035	0.000001
m <sup>3</sup>	1000000	1	1000	61024	35.315	1.30796
Liter	1000	0.001	1	61.024	0.035315	0.001308
in <sup>3</sup>	16.387	0.000016	0.01638	1	0.000578	0.000021
ft <sup>3</sup>	28316.8	0.028317	28.317	1728	1	0.03704
yd <sup>3</sup>	764529.8	0.76453	764.53	46656	27	1

1 gal(US) = 3785.41 cm<sup>3</sup> = 231 in<sup>3</sup> = 0.83267 gal(UK)

## Weight

Unit	g	kg	t	oz	lb
g	1	0.001	0.000001	0.03527	0.0022
kg	1000	1	0.001	35.273	2.20459
t	1000000	1000	1	35273	2204.59
oz	28.3495	0.02835	0.000028	1	0.0625
lb	453.592	0.45359	0.000454	16	1

1 tonne(metric) = 1.1023 ton(US) = 0.9842 ton(UK)

## Pressure

Unit	kgf/cm <sup>2</sup>	bar	Pa=N/m <sup>2</sup>	kPa	lbf/in <sup>2</sup>	lbf/ft <sup>2</sup>
kgf/cm <sup>2</sup>	1	0.98067	98066.5	98.0665	14.2233	2048.16
bar	1.01972	1	100000	100	14.5037	2088.6
Pa=N/m <sup>2</sup>	0.00001	0.001	1	0.001	0.00015	0.02086
kPa	0.01020	0.01	1000	1	0.14504	20.886
lbf/in <sup>2</sup>	0.07032	0.0689	6894.76	6.89476	1	144
lbf/ft <sup>2</sup>	0.00047	0.00047	47.88028	0.04788	0.00694	1

1 kgf/cm<sup>2</sup> = 735.56 Torr(mmHg) = 0.96784 atm

## Approximate conversions

SI	Conversion	Non-SI	Conversion	SI
Unit	Factor	Unit	Factor	Unit
<b>Torque</b>				
newton meter (N·m)	x 10.2	= kgf·cm	x 0.8664	= (lbf·in)
newton meter (N·m)	x 0.74	= lb·ft	x 1.36	= N·m
newton meter (N·m)	x 0.102	= kgf·m	x 7.22	= (lbf·ft)
<b>Pressure (Pa = N/m<sup>2</sup>)</b>				
kilopascal (kPa)	x 4.0	= in. H <sub>2</sub> O	x 0.249	= kPa
kilopascal (kPa)	x 0.30	= in. Hg	x 3.38	= kPa
kilopascal (kPa)	x 0.145	= psi	x 6.89	= kPa
(bar)	x 14.5	= psi	x 0.069	= (bar)
(kgf/cm <sup>2</sup> )	x 14.22	= psi	x 0.070	= (kgf/cm <sup>2</sup> )
(newton/mm <sup>2</sup> )	x 145.04	= psi	x 0.069	= (bar)
megapascal (MPa)	x 145	= psi	x 0.00689	= MPa
<b>Power (W = J/s)</b>				
kilowatt (kW)	x 1.36	= PS (cv)	x 0.736	= kW
kilowatt (kW)	x 1.34	= HP	x 0.746	= kW
kilowatt (kW)	x 0.948	= Btu/s	x 1.055	= kW
watt (W)	x 0.74	= ft·lb/s	x 1.36	= W

Note: ( ) non-si unit

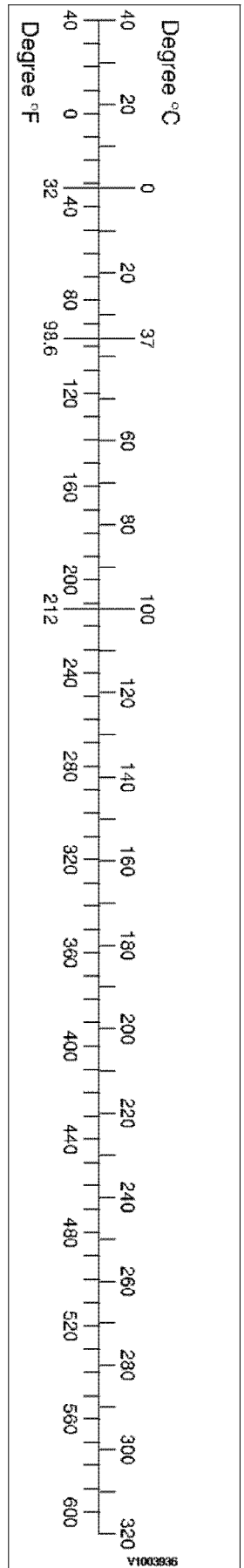

**Approximate conversions**

SI Unit	Conversion Factor	Non-SI Unit	Conversion Factor	SI Unit

Energy (J = N·m)				
kilojoule (kJ)	x 0.948	= Btu	x 1.055	= kJ
joule (J)	x 0.239	= calorie	x 4.19	= J
Velocity and Acceleration				
meter per sec <sup>2</sup> (m/s <sup>2</sup> )	x 3.28	= ft/s <sup>2</sup>	x 0.305	= m/s <sup>2</sup>
meter per sec (m/s)	x 3.28	= ft/s	x 0.305	= m/s
kilometer per hour (km/h)	x 0.62	= mph	x 1.61	= km/h
Horse power/torque				
BHP x 5252 rpm = TQ (lb·ft)			TQ x rpm 5252 = B.H.P.	
Temperature				
°C = (°F - 32) /1.8		°F = (°C x 1.8) + 32		
Flow Rate				
liter/min (dm <sup>3</sup> /min)	x 0.264	= US gal/min x 3.785		= liter/min

Note: ( ) non-si unit

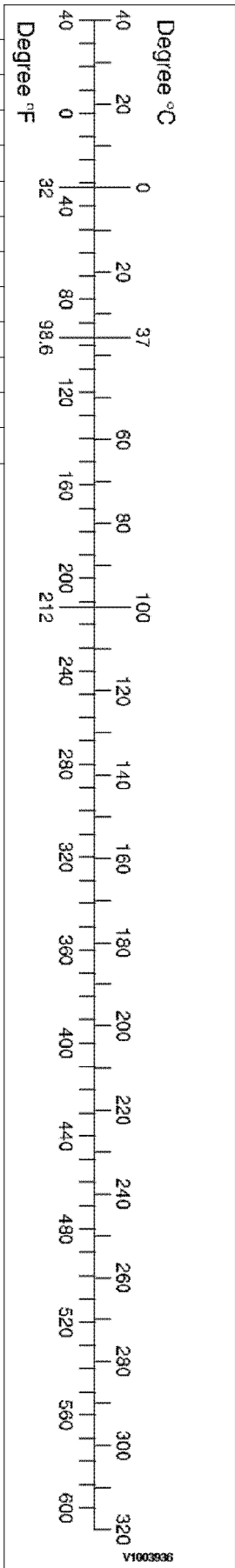

Document Title: <b>Fuel pressure, specifications</b>	Function Group: <b>030</b>	Information Type: <b>Service Information</b>	Date: <b>9/9/2025</b>
Profile: <b>EC210F 3</b>			

## Fuel pressure, specifications

Showing Selected Profile

Valid for serial numbers			
Model	Production site	Serial number start	Serial number stop
EC210F 3			

Fuel feed pressure	
Minimum pressure in engine starting condition	0.35 ±0.05 MPa, 51 ±7 psi, 3.5 ±0.5 bar
Minimum pressure in engine running condition	0.6 ±0.05 MPa, 87 ±7 psi, 6.0 ±0.5 bar
Maximum pressure in the pump pressure relive valve	1.15 ±0.15 MPa, 167 ±22 psi, 11.5 ±1.5 bar

Fuel return pressure	
Maximum pressure in engine starting condition	0.03 MPa, 4.4 psi, 0.3 bar
Maximum pressure in engine running condition	0.05 MPa, 7.3 psi, 0.5 bar

Fuel control unit (FCU) pressure	
Pressure in engine starting condition	0.07 ±0.04 MPa, 10 ±6 psi, 0.7±0.4 bar
Pressure without load in engine running condition	0.1 ±0.01 MPa, 15 ±2 psi, 1 ±0.1 bar
Pressure with load in engine running condition	0.09–0.21 MPa, 13–31 psi, 0.9–2.1 bar
Pressure without regulation in engine running condition	0.45 ±0.02 MPa, 65 ±3 psi, 4.5 ±0.2 bar

High pressure fuel pump output pressure at testing condition	
Output pressure	55 ±5 MPa, 7979 ±725 psi, 550 ±50 bar

Fuel rail pressure	
Pressure in engine starting condition	30 ±5 MPa, 4352 ±725 psi, 300 ±50 bar (at charge air pressure 0 MPa, 0 psi, 0 bar)
Pressure with rail PRV open in running conditions	70 ±5 MPa, 10153 ±725 psi, 700 ±50 bar
Pressure with <b>load above 60%</b> in engine running condition	80–150 MPa, 11606–21762 psi, 800–1500 bar (at charge air pressure 0.05–0.25 MPa, 7.3–36.3 psi, 0.5–2.5 bar)

Document Title: <b>Thermostat, specifications</b>	Function Group: <b>030</b>	Information Type: <b>Service Information</b>	Date: <b>9/9/2025</b>
Profile: <b>EC210F 3</b>			

## Thermostat, specifications

Showing Selected Profile

Valid for serial numbers			
Model	Production site	Serial number start	Serial number stop
EC210F 3			

Thermostat, type	Piston thermostat
Quantity	1
Coolant thermostat begins to open at	83 °C (181 °F)
Coolant thermostat fully open at	95 °C (302 °F)
Coolant thermostat stroke distance	8 mm (0.32 in)

Document Title: <b>Operation numbers for additional work</b>	Function Group: <b>070</b>	Information Type: <b>Service Information</b>	Date: <b>9/9/2025</b>
Profile: <b>Excavators (EXC)</b>			

## Operation numbers for additional work

Showing Selected Profile

These operations can be used to identify work that is not included in the time guide or described in the methods in the Service Manual. When these operations are used, a description of the work that has been performed must be provided.

### Other work related to engine

Op. no. 070-210

This operation can be used when work has been done related to the engine and function group 2 when no applicable method description was available. When this operation is used, additional information is required:

- Description of work that has been done

### Other work related to electrical system

Op. no. 070-310

This operation can be used when work has been done related to the electrical system and function group 3 when no applicable method description was available. When this operation is used, additional information is required:

- Description of work that has been done

### Other work related to transmission, gearbox, travel motor, swing motor

Op. no. 070-410

This operation can be used when work has been done related to the transmission, gearbox, travel motor or swing motor and function group 4 when no applicable method description was available. When this operation is used, additional information is required:

- Description of work that has been done

### Other work related to drive axle

Op. no. 070-470

This operation can be used when work has been done related to the drive axle and function group 46 when no applicable method description was available. When this operation is used, additional information is required:

- Description of required work that have been done

### Other work related to brake system

Op. no. 070-510

This operation can be used when work has been done related to the brake system and function group 5 when no applicable

method description was available. When this operation is used, additional information is required:

- Description of work that has been done

**Other work related to steering system**

Op. no. 070-610

This operation can be used when work has been done related to the steering system and function group 6 when no applicable method description was available. When this operation is used, additional information is required:

- Description of work that has been done

**Other work related to frame link, axle suspension**

Op. no. 070-710

This operation can be used when work has been done related to the frame link, axle suspension and other parts related to function group 7 when no applicable method description was available. When this operation is used, additional information is required:

- Description of work that has been done

**Other work related to cab, air conditioning**

Op. no. 070-810

This operation can be used when work has been done related to the cab, air conditioning and other parts related to function group 8 when no applicable method description was available. When this operation is used, additional information is required:

- Description of work that has been done

**Other work related to hydraulic system**

Op. no. 070-910

This operation can be used when work has been done related to the hydraulic system and other parts related to function group 9 when no applicable method description was available. When this operation is used, additional information is required:

- Description of work that has been done

Document Title: <b>E-tools, NET 8940-00270 Replace tool for the swing ring gear</b>	Function Group: <b>080</b>	Information Type: <b>Service Information</b>	Date: <b>9/9/2025</b>
Profile: <b>EC210F 3</b>			

### E-tools, NET 8940-00270 Replace tool for the swing ring gear

Showing Selected Profile

Valid for serial numbers			
Model	Production site	Serial number start	Serial number stop
EC210F 3			

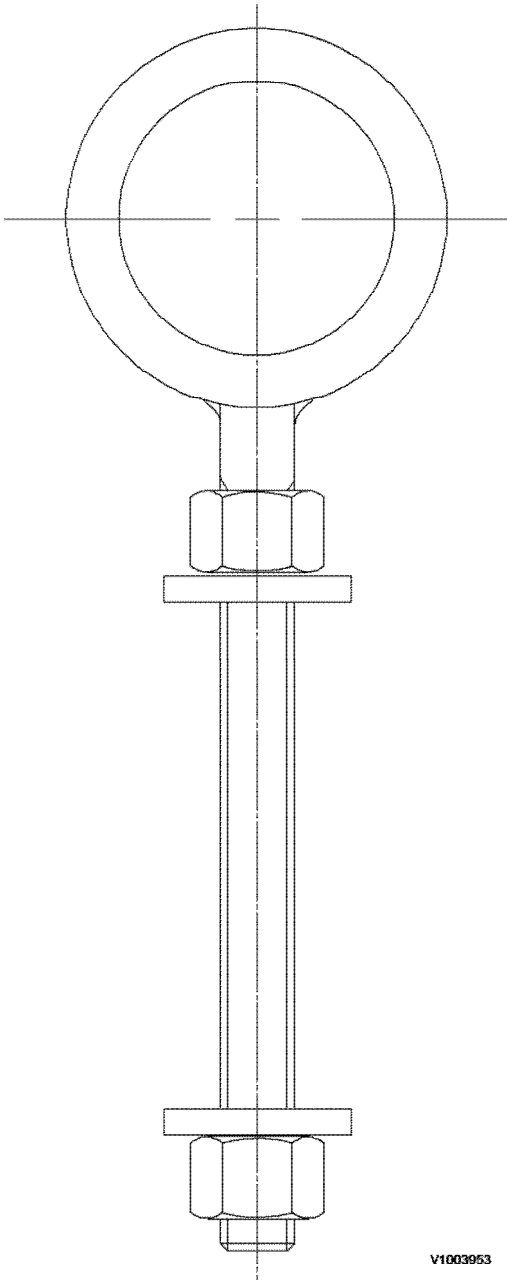

V1003953

**Figure 1**

Replace tool for the swing ring gear

<b>Item</b>	<b>Quantity</b>	<b>Name</b>	<b>Remark</b>
1	2	Ring	SAE 1045 (QT)
2	2	Round bar	SAE 1045 (QT)
3	4	Nut	M18
4	4	Washer	

Document Title: <b>E-tools, NET 8940-00310 Replace tool for the swing ring gear</b>	Function Group: <b>080</b>	Information Type: <b>Service Information</b>	Date: <b>9/9/2025</b>
Profile: <b>EC210F 3</b>			

### E-tools, NET 8940-00310 Replace tool for the swing ring gear

Showing Selected Profile

Valid for serial numbers			
Model	Production site	Serial number start	Serial number stop
EC210F 3			

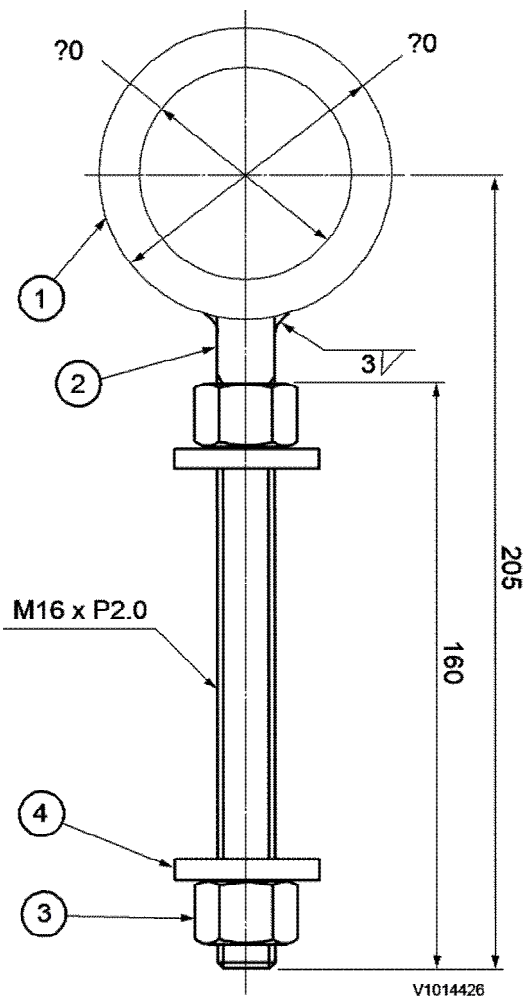

**Figure 1**

Replace tool for the swing ring gear

Item	Quantity	Name	Remark
1	2	Ring	SAE 1045 (QT)
2	2	Round bar $\phi 16$	SAE 1045 (QT)
3	4	Nut	M16

4

4

Washer  $\varphi 16 \times \varphi 35 \times 10$  t

Document Title: <b>E-tools, NET 8940-00320 Swing motor guide pin and swing ring gear</b>	Function Group: <b>080</b>	Information Type: <b>Service Information</b>	Date: <b>9/9/2025</b>
Profile: <b>EC210F 3</b>			

**E-tools, NET 8940-00320 Swing motor guide pin and swing ring gear**

Showing Selected Profile

Valid for serial numbers			
Model	Production site	Serial number start	Serial number stop
EC210F 3			

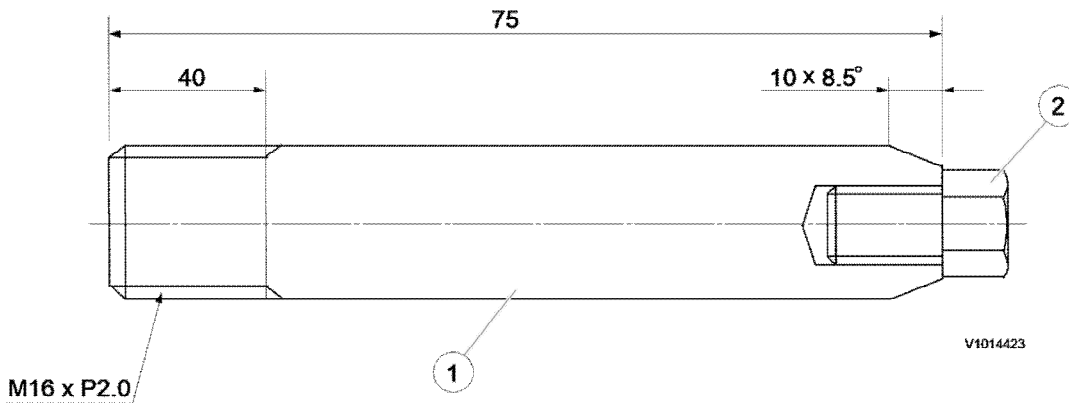

**Figure 1**  
Swing motor guide pin

Item	Quantity	Name	Remark
1	2	Guide bar	SAE 4130 (25 ~ 35 HRC)
2	2	Screw	M8 × 1.0 × 16L

Document Title: <b>Infrared Thermometer</b>	Function Group: <b>080</b>	Information Type: <b>Service Information</b>	Date: <b>9/9/2025</b>
Profile: <b>EC210F 3</b>			

## Infrared Thermometer

Showing Selected Profile

Valid for serial numbers			
Model	Production site	Serial number start	Serial number stop
EC210F 3			

### Gun Style Infrared Thermometer Laser Sight Model: SIG1

#### 9998519 Infrared thermometer (user instruction in FGI 080) Application

This tool can be used to measure fast and easy temperature differences. For instance in case of troubleshooting it is sometimes necessary to measure temperature differences on two equal parts with the same surface.



### **WARNING**

Never point the device towards the eyes permanent eye damage may occur. Use extreme caution when using the laser. Keep out of the reach of children. Be careful around mirror surfaces since mirrors can reflect the laser. Looking into the reflected laser is just as damaging as looking directly at the laser.

#### General information

1. Field of view: The SIG1 takes it's measurement from a circle of a size determined by a simple ratio of 10:1. The diameter of this circle is 1/10 the distance between the target and the tip of the SIG1. For example, if you're standing 20 feet (610 cm) from your target, the size of the circle you're taking the average temperature of will be 2 feet (61 cm) wide.
2. If you want to get the temperature of something small, such as a pipe, you must get close enough for the pipe to take up the whole viewing area circle. Otherwise the pipe and the background temperatures will be averaged into the reading.
3. You need to be aware that if the target surface is reflective enough, it may reflect infrared from other objects. For example, if you take a reading of a shiny metal surface, the infrared energy of your face may reflect enough energy off the surface to affect the reading. For this reason, it's a good idea to put non-reflective tape or paint on reflective surfaces when taking infrared temperature readings.

#### NOTE!

The measured temperature will be lower than actual.

#### Operation

1. Point the laser towards the target to be measured.
2. Pull trigger to light the target with the laser and measure its surface temperature.
3. As long as the trigger is held down, the SIG1 will constantly update the measurement and the blue backlight will illuminate the display.
4. When the trigger is pulled the red laser dot will shine about 1/4" above the centre of the circular area being measured by the thermometer.
5. Once the trigger is released, the last measurement will be shown and held until the trigger is pressed again or until the SIG1 turns off.

Document Title: <b>E-tool, 3502 Plate for turning crankshaft</b>	Function Group: <b>080</b>	Information Type: <b>Service Information</b>	Date: <b>9/9/2025</b>
Profile: <b>EC210F 3</b>			

## E-tool, 3502 Plate for turning crankshaft

Showing Selected Profile

Valid for serial numbers			
Model	Production site	Serial number start	Serial number stop
EC210F 3			

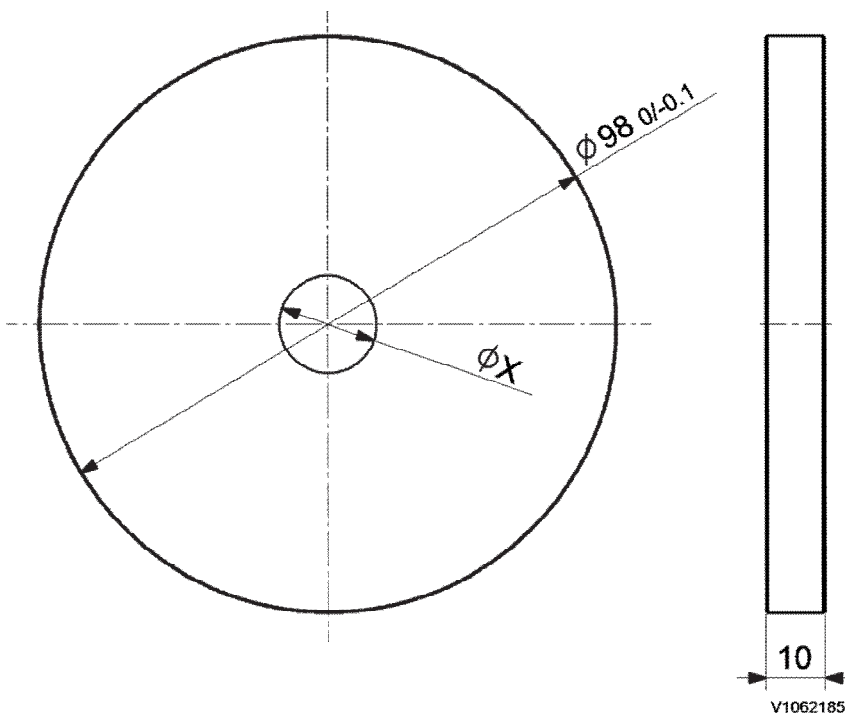

**Figure 1**

Support plate for engine valve clearance adjusting (unit: mm)

X: Shaft diameter of a ratchet extension

Material: Steel or plastic

Document Title: <b>Service positions</b>	Function Group: <b>091</b>	Information Type: <b>Service Information</b>	Date: <b>9/9/2025</b>
Profile: <b>EC210F 3</b>			

## Service positions

Showing Selected Profile

Valid for serial numbers			
Model	Production site	Serial number start	Serial number stop
EC210F 3			

Park the machine on a horizontal and firm surface.  
The suitable position is indicated in the description for the various service jobs.  
Before beginning any work on the machine.

- Turn off the engine and remove the ignition key.
- Depressurize all pressurized lines and pressure vessels carefully so that high pressure is released without risk.
- Allow the machine to cool down.

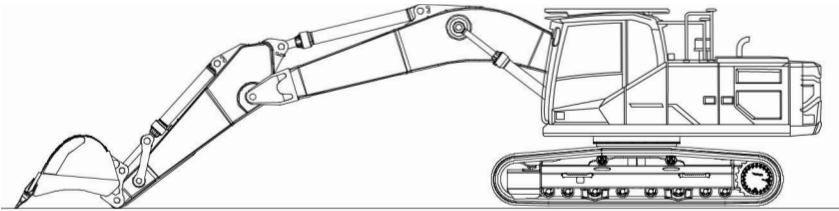

V1253062

**Figure 1**  
Service position A

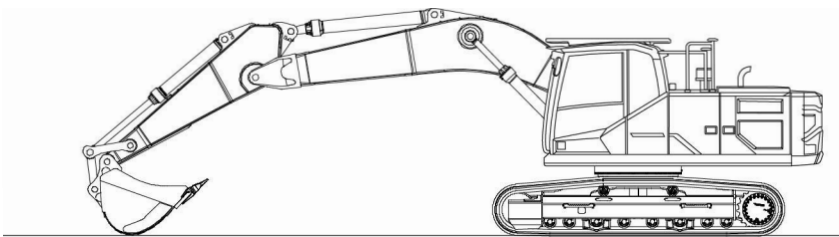

V1253064

**Figure 2**  
Service position B

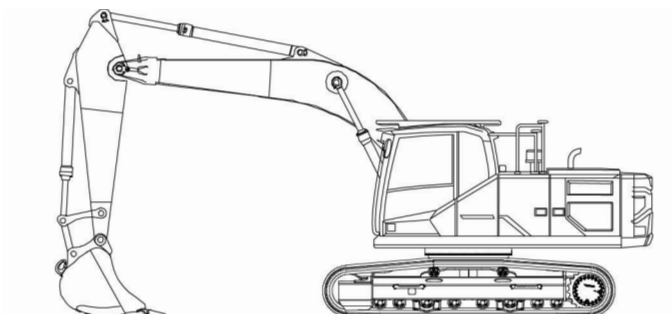

V1253063

**Figure 3**  
Service position C

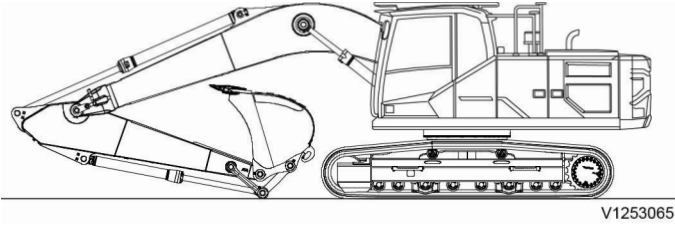

**Figure 4**  
Service position D

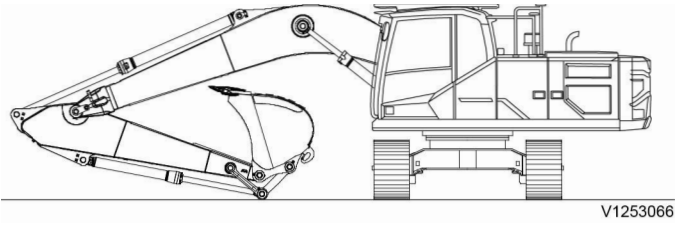

**Figure 5**  
Service position E

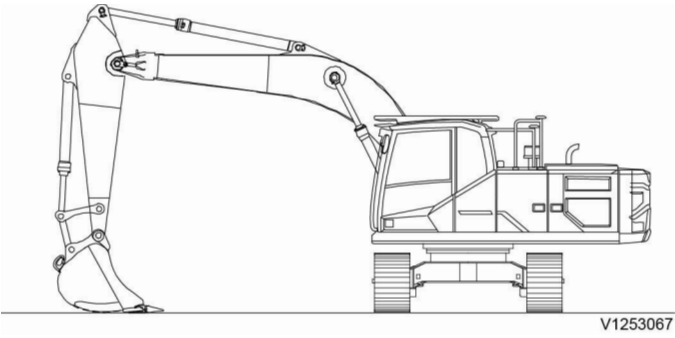

**Figure 6**  
Service position F

Document Title: <b>Welding on the machine</b>	Function Group: <b>091</b>	Information Type: <b>Service Information</b>	Date: <b>9/9/2025</b>
Profile: <b>EC210F 3</b>			

## Welding on the machine

Showing Selected Profile

Valid for serial numbers			
Model	Production site	Serial number start	Serial number stop
EC210F 3			

### NOTICE

**During electric welding on the machine or attachments connected to the machine, components such as bearings and electric units may be damaged if the ground cable is connected incorrectly.**

The following actions should be taken before starting electric welding to eliminate these risks:

1. Turn off the electric power using the battery disconnect.
2. Disconnect the batteries.  
**NOTE!**  
Both the plus and minus terminal.
3. Disconnect the all electronic units.
  - General Purpose Machine Electronic Control Unit (GPMECU)
  - Human Machine Interface Control Unit (HMICU)
  - Engine Control Module (ECM)
  - Instrument Control (IC)
  - Climate Control Module (CCM)
  - Care Track control unit (W-ECU)
  - Gateway Control Unit (mGPM)
  - Key Pad 1
  - Key Pad 2
4. Connect the welding unit's ground connection as close as possible to the welding point, and make sure that the current does not pass across a bearing.

If welding is necessary on the boom or dipper arm, the following basic rules should be followed:

1. Welding beads should be laid down in the longitudinal direction.
2. If possible, weld in the middle of the metal section and never closer than **80 mm** to an edge.
3. Do not weld near the welded connections of the cylinder mounting eyes. Minimum distance from eye's weld to weld for weld lug = **100 mm**.
4. Do not weld close to where a metal plate has been bent.

Document Title: <b>Hydraulic cylinders, dieseling</b>	Function Group: <b>091</b>	Information Type: <b>Service Information</b>	Date: <b>9/9/2025</b>
Profile: <b>EC210F 3</b>			

## Hydraulic cylinders, dieseling

Showing Selected Profile

Valid for serial numbers			
Model	Production site	Serial number start	Serial number stop
EC210F 3			

If air enters the hydraulic cylinders during work on the hydraulic system, this can lead to spontaneous ignition, an effect known as dieseling. This occurs if a favourable mixture of air and hydraulic oil is compressed when the piston approaches its end position in the cylinder. A sufficiently high temperature can be reached for the mixture to spontaneously ignite.

### **NOTICE**

**The dieseling effect may result in burnt piston seals and bushings.**

In order to prevent dieseling, the lines for the hydraulic cylinders must be bled after work is completed, as follows:

1. No load and keep the lowest engine rpm
2. Operate the piston slowly up to the middle of cylinder in order to remove air from inner chamber of cylinder. Repeat over 5 times.  
After that, operate the piston up to the end of cylinder in order to remove residual air from cylinder, pipe and hose gradually. Repeat over 5 times.

### **NOTICE**

**If the cylinders are pressurized either through lifting of the machine or lifting of a load in the bucket, without first performing the mentioned bleeding movements, the seals will likely be damaged.**

If a cylinder is to be pressure-tested after a repair, the piston rod should be run in and out a few times before increasing the pressure to testing pressure.

Document Title: <b>Recommended lubricants</b>	Function Group: <b>160</b>	Information Type: <b>Service Information</b>	Date: <b>9/9/2025</b>
Profile: <b>EC210F 3</b>			

## Recommended lubricants

Showing Selected Profile

Valid for serial numbers			
Model	Production site	Serial number start	Serial number stop
EC210F 3			

The Volvo lubricants have been specially developed to fulfil the demanding operating conditions, in which Volvo excavators are used in. The oils have been tested according to Volvo excavator specifications and therefore meet the high requirements for safety and quality. Other mineral oils can be used if they conform to our viscosity recommendations and meet our quality requirements. The approval of Volvo is required, if any other oil base quality (for example biologically degradable oil) is to be used.

### NOTE!

If a high water or excessive contamination in the lubricants (e.g. engine oil, hydraulic oil, axle oil, etc.) is found by Volvo oil analysis, change the lubricants regardless of the change interval.

See service bulletins "Oil sampling" in function group 160.

System	Oil grade	Recommended viscosity at varying ambient temperature																				
Engine	Engine oil For detail, see page <a href="#">Engine oil</a> .	<table border="1"> <tr> <td>°C</td> <td>-30</td> <td>-20</td> <td>-10</td> <td>0</td> <td>+10</td> <td>+20</td> <td>+30</td> <td>+40</td> <td>+50</td> </tr> <tr> <td>°F</td> <td>-22</td> <td>-4</td> <td>+14</td> <td>+32</td> <td>+50</td> <td>+68</td> <td>+86</td> <td>+104</td> <td>+122</td> </tr> </table>	°C	-30	-20	-10	0	+10	+20	+30	+40	+50	°F	-22	-4	+14	+32	+50	+68	+86	+104	+122
°C	-30	-20	-10	0	+10	+20	+30	+40	+50													
°F	-22	-4	+14	+32	+50	+68	+86	+104	+122													
Fuel	Diesel fuel For detail, see page <a href="#">Fuel</a> .	<table border="1"> <tr> <td>°C</td> <td>-30</td> <td>-20</td> <td>-10</td> <td>0</td> <td>+10</td> <td>+20</td> <td>+30</td> <td>+40</td> <td>+50</td> </tr> <tr> <td>°F</td> <td>-22</td> <td>-4</td> <td>+14</td> <td>+32</td> <td>+50</td> <td>+68</td> <td>+86</td> <td>+104</td> <td>+122</td> </tr> </table> <p><b>NOTE!</b> The fuel should at least meet the legal requirement, and national and international standards for marketed fuels, for example : EN590 (with nationally adapted temperature requirements), ASTM D975 No 1-D and No 2-D, JIS KK 2204.</p>	°C	-30	-20	-10	0	+10	+20	+30	+40	+50	°F	-22	-4	+14	+32	+50	+68	+86	+104	+122
°C	-30	-20	-10	0	+10	+20	+30	+40	+50													
°F	-22	-4	+14	+32	+50	+68	+86	+104	+122													
Cooling system	<b>Volvo Coolant VCS-2 Ready Mixed</b> For detail, see page <a href="#">Coolant</a> .	<b>Volvo Coolant VCS Ready Mixed</b> should be used only. <b>NOTE!</b> The content of Volvo coolant must not be less than 40% of the total mixture.																				

\*: Installed at factory

\*\*\*: VDS-4 or VDS-4.5 approved oils only. Other oils can be used up to +30°C (86°F).

System	Oil grade	Recommended viscosity at varying ambient temperature																				
Hydraulic system	Hydraulic oil for severe cold area or if siberian option kit is installed	<table border="1"> <tr> <td>°C</td> <td>-30</td> <td>-20</td> <td>-10</td> <td>0</td> <td>+10</td> <td>+20</td> <td>+30</td> <td>+40</td> <td>+50</td> </tr> <tr> <td>°F</td> <td>-22</td> <td>-4</td> <td>+14</td> <td>+32</td> <td>+50</td> <td>+68</td> <td>+86</td> <td>+104</td> <td>+122</td> </tr> </table> <p>ISO VG15</p>	°C	-30	-20	-10	0	+10	+20	+30	+40	+50	°F	-22	-4	+14	+32	+50	+68	+86	+104	+122
	°C	-30	-20	-10	0	+10	+20	+30	+40	+50												
	°F	-22	-4	+14	+32	+50	+68	+86	+104	+122												
	Volvo Hydraulic Oil 98609 Extra 32 or Volvo Hydraulic Oil 98609 Extra 46 or Volvo Hydraulic Oil 98609 Extra 68 or Volvo Hydraulic Oil 98611 HO103 32 Volvo Hydraulic Oil 98611 HO103 46 Volvo Hydraulic Oil 98611 HO103 68	<table border="1"> <tr> <td>°C</td> <td>-30</td> <td>-20</td> <td>-10</td> <td>0</td> <td>+10</td> <td>+20</td> <td>+30</td> <td>+40</td> <td>+50</td> </tr> <tr> <td>°F</td> <td>-22</td> <td>-4</td> <td>+14</td> <td>+32</td> <td>+50</td> <td>+68</td> <td>+86</td> <td>+104</td> <td>+122</td> </tr> </table> <p>ISO VG32 HV ISO VG46 HV ISO VG68 HV</p>	°C	-30	-20	-10	0	+10	+20	+30	+40	+50	°F	-22	-4	+14	+32	+50	+68	+86	+104	+122
°C	-30	-20	-10	0	+10	+20	+30	+40	+50													
°F	-22	-4	+14	+32	+50	+68	+86	+104	+122													
Volvo Hydraulic Oil 98610 Biodegradable 46	<table border="1"> <tr> <td>°C</td> <td>-30</td> <td>-20</td> <td>-10</td> <td>0</td> <td>+10</td> <td>+20</td> <td>+30</td> <td>+40</td> <td>+50</td> </tr> <tr> <td>°F</td> <td>-22</td> <td>-4</td> <td>+14</td> <td>+32</td> <td>+50</td> <td>+68</td> <td>+86</td> <td>+104</td> <td>+122</td> </tr> </table> <p>Bio oil VG46</p> <p><b>NOTE!</b> If the machine is filled with Volvo Biodegradable hydraulic oil this oil must also be used when filling and changing. The mineral oil content in bio oil should not exceed 2% when changing from mineral oil to bio oil. Contact a workshop authorised by Volvo.</p>	°C	-30	-20	-10	0	+10	+20	+30	+40	+50	°F	-22	-4	+14	+32	+50	+68	+86	+104	+122	
°C	-30	-20	-10	0	+10	+20	+30	+40	+50													
°F	-22	-4	+14	+32	+50	+68	+86	+104	+122													
Volvo Hydraulic Oil 98620 Ultra 32 or Volvo Hydraulic Oil 98620 Ultra 46 or Volvo Hydraulic Oil 98620 Ultra 68	<table border="1"> <tr> <td>°C</td> <td>-30</td> <td>-20</td> <td>-10</td> <td>0</td> <td>+10</td> <td>+20</td> <td>+30</td> <td>+40</td> <td>+50</td> </tr> <tr> <td>°F</td> <td>-22</td> <td>-4</td> <td>+14</td> <td>+32</td> <td>+50</td> <td>+68</td> <td>+86</td> <td>+104</td> <td>+122</td> </tr> </table> <p>ISO VG32 ISO VG46 ISO VG68</p>	°C	-30	-20	-10	0	+10	+20	+30	+40	+50	°F	-22	-4	+14	+32	+50	+68	+86	+104	+122	
°C	-30	-20	-10	0	+10	+20	+30	+40	+50													
°F	-22	-4	+14	+32	+50	+68	+86	+104	+122													

System	Oil grade	Recommended viscosity at varying ambient temperature																				
Track gearbox	Volvo Axle Oil 97321 80W-90 or	<table border="1"> <tr> <td>°C</td> <td>-30</td> <td>-20</td> <td>-10</td> <td>0</td> <td>+10</td> <td>+20</td> <td>+30</td> <td>+40</td> <td>+50</td> </tr> <tr> <td>°F</td> <td>-22</td> <td>-4</td> <td>+14</td> <td>+32</td> <td>+50</td> <td>+68</td> <td>+86</td> <td>+104</td> <td>+122</td> </tr> </table> <p>*SAE 90 SAE 140</p>	°C	-30	-20	-10	0	+10	+20	+30	+40	+50	°F	-22	-4	+14	+32	+50	+68	+86	+104	+122
°C	-30		-20	-10	0	+10	+20	+30	+40	+50												
°F	-22	-4	+14	+32	+50	+68	+86	+104	+122													
Swing gearbox	Volvo Axle Oil 97321 80W-140 or	<p>Or corresponding gearbox oil below.</p> <ul style="list-style-type: none"> <li>○ Mobil SHC630</li> <li>○ Volvo Synthetic Drum Eccentric Oil</li> </ul>																				
PTO gearbox (EC950 only)	Volvo Axle Oil 97317 75W-80 GO102 or Volvo Synthetic Axle Oil 97312 75W-90 or Volvo Axle Oil 97321 85W-90 Limited Slip																					
Swing ring gear (Bath and Ball)	Volvo Multipurpose Grease 97718 GR101	<table border="1"> <tr> <td>°C</td> <td>-30</td> <td>-20</td> <td>-10</td> <td>0</td> <td>+10</td> <td>+20</td> <td>+30</td> <td>+40</td> <td>+50</td> </tr> <tr> <td>°F</td> <td>-22</td> <td>-4</td> <td>+14</td> <td>+32</td> <td>+50</td> <td>+68</td> <td>+86</td> <td>+104</td> <td>+122</td> </tr> </table> <p>Multi purpose EP** grease NLGI 2</p> <p>Or corresponding grease on lithium base with EP** additives and consistency NLGI class 2.</p>	°C	-30	-20	-10	0	+10	+20	+30	+40	+50	°F	-22	-4	+14	+32	+50	+68	+86	+104	+122
°C	-30	-20	-10	0	+10	+20	+30	+40	+50													
°F	-22	-4	+14	+32	+50	+68	+86	+104	+122													
Pin and bushing	Volvo Extreme Grease 97765 GR103 or Volvo Multipurpose Grease 97718 GR101[T1] ⓘ For detail, see page <a href="#">Grease</a> .	<table border="1"> <tr> <td>°C</td> <td>-30</td> <td>-20</td> <td>-10</td> <td>0</td> <td>+10</td> <td>+20</td> <td>+30</td> <td>+40</td> <td>+50</td> </tr> <tr> <td>°F</td> <td>-22</td> <td>-4</td> <td>+14</td> <td>+32</td> <td>+50</td> <td>+68</td> <td>+86</td> <td>+104</td> <td>+122</td> </tr> </table> <p>*ISO-L-XBCFB2</p> <p>Or corresponding grease on lithium base with EP** additives and consistency NLGI class 2.</p>	°C	-30	-20	-10	0	+10	+20	+30	+40	+50	°F	-22	-4	+14	+32	+50	+68	+86	+104	+122
°C	-30	-20	-10	0	+10	+20	+30	+40	+50													
°F	-22	-4	+14	+32	+50	+68	+86	+104	+122													
Air conditioner system	Refrigerant	HFC R134a																				

[T1] Volvo Multipurpose Grease 97718 GR101 is not recommended when the ambient temperature is above 40 °C.

Product: Volvo EC210F 3 Excavators Service Manual

Full Download: <https://www.arepairmanual.com/downloads/volvo-ec210f-3-excavators-service-manual/>

\*: Installed at factory

\*\* : Extreme Pressure

Sample of manual. Download All 2165 pages at:

<https://www.arepairmanual.com/downloads/volvo-ec210f-3-excavators-service-manual/>