

| | | | |
|--|-------------------------------|---|---------------------------|
| Document Title: Machine view | Function Group: 000 | Information Type: Service Information | Date: 8/14/2025 |
| Profile: EC210D Volvo | | | |

[Go back to Index Page](#)

Machine view

Showing Selected Profile

| Valid for serial numbers | | | |
|--------------------------|-----------------|---------------------|--------------------|
| Model | Production site | Serial number start | Serial number stop |
| EC210D Volvo | | | |

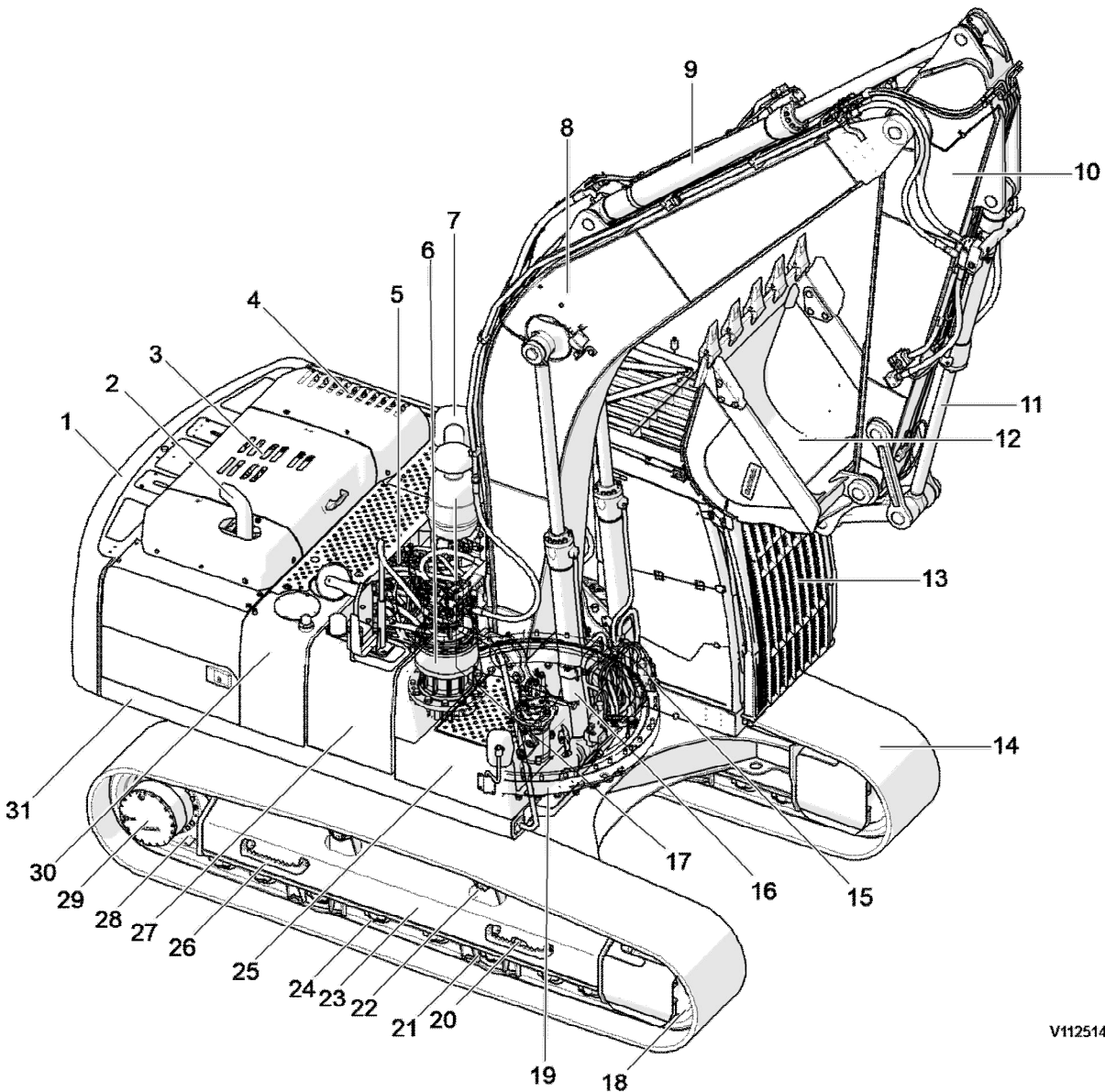

V1125143

Figure 1

Sample of manual Download All 2405 pages at

<https://www.arepairmanual.com/downloads/volvo-ec210d-excavators-service-manual/>

Product: Volvo EC210D Excavators Service Manual

Full Download: <https://www.arepairmanual.com/downloads/volvo-ec210d-excavators-service-manual/>

| | | | |
|----|--------------------------------|----|----------------------------|
| 1 | Counterweight | 17 | Oil bath air cleaner |
| 2 | Muffler | 18 | Idler |
| 3 | Engine | 19 | Swing ring gear |
| 4 | Radiator and charge air cooler | 20 | Track tension grease valve |
| 5 | Main control valve | 21 | Track guard |
| 6 | Swing motor and gearbox | 22 | Top roller |
| 7 | Air cleaner | 23 | Lower frame |
| 8 | Boom | 24 | Bottom roller |
| 9 | Dipper arm cylinder | 25 | Battery |
| 10 | Dipper arm | 26 | Steps |
| 11 | Bucket cylinder | 27 | Fuel tank |
| 12 | Bucket | 28 | Sprocket |
| 13 | Operator's cab | 29 | Track motor and gearbox |
| 14 | Track chain | 30 | Hydraulic tank |
| 15 | Line rupture valves | 31 | Upper frame |
| 16 | Boom cylinder | | |

Sample of manual. Download All 2405 pages at:

<https://www.arepairmanual.com/downloads/volvo-ec210d-excavators-service-manual/>

| | | | |
|--|-------------------------------|---|---------------------------|
| Document Title: Machine view | Function Group: 000 | Information Type: Service Information | Date: 8/14/2025 |
| Profile: EC210D Volvo | | | |

[Go back to Index Page](#)

Machine view

Showing Selected Profile

| Valid for serial numbers | | | |
|--------------------------|-----------------|---------------------|--------------------|
| Model | Production site | Serial number start | Serial number stop |
| EC210D Volvo | Bangalore | 250001 | 280000 |

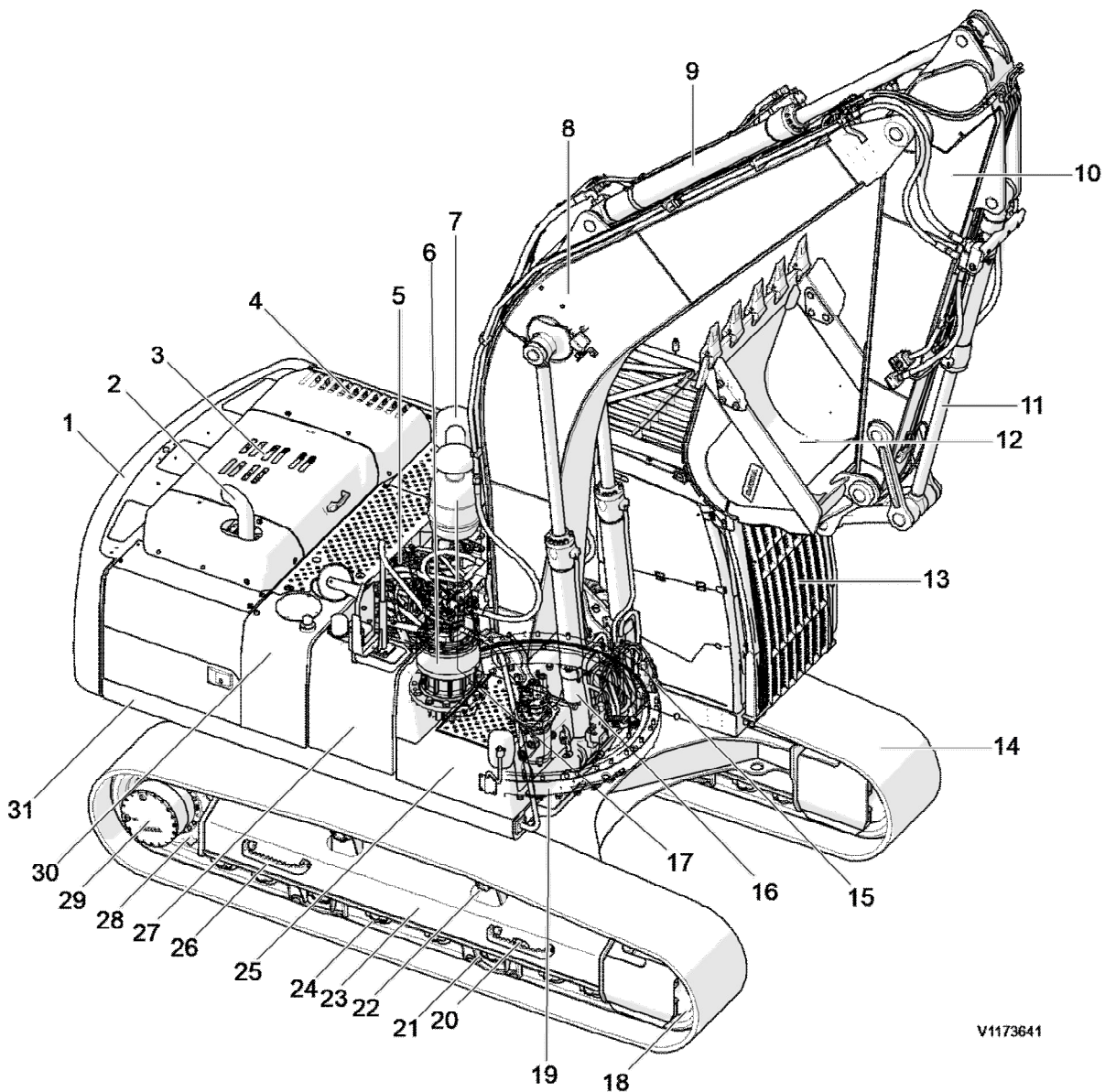

V1173641

Figure 1
Components location

| | | | |
|----|--------------------------------|----|----------------------------|
| 1 | Counterweight | 17 | Oil bath air cleaner |
| 2 | Muffler | 18 | Idler |
| 3 | Engine | 19 | Swing ring gear |
| 4 | Radiator and charge air cooler | 20 | Track tension grease valve |
| 5 | Main control valve | 21 | Track guard |
| 6 | Swing motor and gearbox | 22 | Top roller |
| 7 | Air cleaner | 23 | Lower frame |
| 8 | Boom | 24 | Bottom roller |
| 9 | Dipper arm cylinder | 25 | Battery |
| 10 | Dipper arm | 26 | Steps |
| 11 | Bucket cylinder | 27 | Fuel tank |
| 12 | Bucket | 28 | Sprocket |
| 13 | Operator's cab | 29 | Track motor and gearbox |
| 14 | Track chain | 30 | Hydraulic tank |
| 15 | Line rupture valves | 31 | Upper frame |
| 16 | Boom cylinder | | |

| | | | |
|--|-------------------------------|---|---------------------------|
| Document Title: Product plates | Function Group: 000 | Information Type: Service Information | Date: 8/14/2025 |
| Profile: EC210D Volvo | | | |

Product plates

Showing Selected Profile

| Valid for serial numbers | | | |
|--------------------------|-----------------|---------------------|--------------------|
| Model | Production site | Serial number start | Serial number stop |
| EC210D Volvo | | | |

Please refer to the figure below to locate the product plate, engine plate, cab plate and attachment plates. Always use the Product Identification Number (PIN) provided on the vehicle and/or engine plates for troubleshooting purposes and/or when ordering spare parts.

1. Product plate

This plate with Product Identification Number, PIN, for the complete machine indicates the model designation, serial number and when applicable, machine weight, engine power, manufacturing year and CE approval. The plate is positioned on the right side of the upper frame.

Models (General application)

Volvo Crawler excavators and Wheel Excavator are available in different sizes from 5 ton to 95 ton. Some machines can be equipped with different Attachments, Demolition, High Reach Demolition, Pipe Layer, Rotating Pipelayer Kit machine and Dozer blade.

| | | | |
|---------|--------------------------------------|---------|---------------------------|
| EC | Excavator Crawler | EW | Excavator Wheel |
| ECR | Excavator Crawler Short-Swing-Radius | AG | Agricultural machines |
| PL | Pipe Layer | FE | Feller Bunchers |
| L, LC | Long Crawler | NLD | Narrow Crawler Demolition |
| N, NC | Narrow Crawler | HR | High Reach Demolition |
| NL, NLC | Narrow Long Crawler | F, FX | Forestry Application |
| LM, LCM | Long Crawler Marsh | LD, LCD | Long Crawler Demolition |
| LR | Long Reach Boom & Arm | LC4 | Long Crawler 4 |
| LHDS | Long Crawler Heavy Duty Shanghai | LS | Long Crawler Shanghai |
| LHDC | Long Crawler Heavy Duty Changwon | NH | Narrow Heavy Duty |
| LRC4 | Long Reach Crawler 4 (Boom & Arm) | | |

Supplementary PIN plate (EU countries only)

| | | | | | | | | | | | | | | | | |
|---|---|---|---|---|---|---|---|---|---|---|---|---|---|---|---|---|
| V | C | E | E | C | 3 | 5 | C | C | 0 | 0 | 0 | 1 | 2 | 3 | 4 | 5 |
| A | | | B | | | | C | | D | | | | | | | |

V1076896

Figure 1

Example of 17 digit PIN number on PIN plate

- A. World Manufacturing Code
- B. Machine description
- C. Check letters
- D. Serial number

The supplementary plate contains information about machine mass in kg, engine net power in Kw, manufacturing year, machine serial number and a CE-mark.

Machine mass

The machine mass in kg on the supplementary PIN plate is based on:

- cab or canopy
- most used track type
- most usual bucket (without load)
- full fuel tank

For safety reasons, 103 % of the machine mass will be shown on the supplementary PIN plate.

2. Engine

The engine type designation, part and serial numbers are stamped on the top of valve cover.

3. Attachment quick coupler

This nameplate is attached on the outside of the bracket and indicates the part number and weight.

4. Bucket

This nameplate is attached on the top of the bucket and indicates the bucket model order number, serial number, bucket part number, rated capacity, weight, cutting width, tooth part number, and adapter part number.

5. Cab

The nameplate is attached on the inside of the cab and indicates the product number, serial number, model type, and weight.

| | | | |
|---|-------------------------------|---|---------------------------|
| Document Title: Volvo standard tightening torques | Function Group: 030 | Information Type: Service Information | Date: 8/14/2025 |
| Profile: EC210D Volvo | | | |

Volvo standard tightening torques

Showing Selected Profile

| Valid for serial numbers | | | |
|--------------------------|-----------------|---------------------|--------------------|
| Model | Production site | Serial number start | Serial number stop |
| EC210D Volvo | | | |

The tightening torques in the following tables apply to bolts and nuts with tensile strength. The tables should be used as a general instruction for tightening bolts and nuts without specified values. The charts contains values for course thread bolts and nuts.

Torque values should be increased with $\approx 10\%$, for flange bolts.

All standard torques for bolts are without surface treatment.

The standard torque for bolts lubricated with oil should be reduced with 20% of the given value.

Standard tightening torque charts

| Bolt size Metric Coarse Threads | Tensile strength 8.8 | | Tensile strength 10.9 | |
|---------------------------------------|----------------------|----------|-----------------------|----------|
| | (Nm) | (lbf ft) | (Nm) | (lbf ft) |
| M5 | 6 | 4 | 8 | 6 |
| M6 | 10 | 7 | 14 | 11 |
| M8 | 25 | 18 | 35 | 26 |
| M10 | 50 | 37 | 70 | 52 |
| M12 | 87 | 64 | 122 | 90 |
| M14 | 139 | 103 | 195 | 144 |
| M16 | 213 | 157 | 299 | 220 |
| M18 | 293 | 216 | 413 | 305 |
| M20 | 416 | 307 | 585 | 432 |
| M24 | 719 | 530 | 1010 | 745 |
| M27 | 1060 | 782 | 1490 | 1100 |
| M30 | 1140 | 840 | 2025 | 1493 |
| M36 | 2500 | 1844 | 3600 | 2653 |

| Bolt size Inch SAE Coarse Threads | Tensile strength 5 | | Tensile strength 8 | |
|---|--------------------|------|--------------------|------|
| | (lbf ft) | (Nm) | (lbf ft) | (Nm) |
| 1/4 | 10 | 13,6 | 14 | 19 |
| 5/16 | 21 | 28,5 | 29 | 39,3 |
| 3/8 | 37 | 50,2 | 52 | 70 |
| 7/16 | 59 | 80 | 84 | 114 |
| 1/2 | 90 | 122 | 128 | 174 |
| 9/16 | 130 | 176 | 184 | 250 |
| 5/8 | 180 | 244 | 254 | 345 |

| | | | | |
|-------|------|------|------|------|
| 3/4 | 320 | 434 | 451 | 612 |
| 7/8 | 515 | 700 | 728 | 988 |
| 1 | 775 | 1052 | 1091 | 1480 |
| 1 1/8 | 953 | 1290 | 1545 | 2100 |
| 1 1/4 | 1344 | 1823 | 2180 | 2960 |
| 1 3/8 | 1600 | 2170 | 2650 | 3600 |
| 1 1/2 | 2000 | 2714 | 3200 | 4340 |

Hydraulic connections, general

Before fitting pipe couplings, plugs and hoses:

- Make sure that the sealing surfaces are clean and free from pores or scratches.
- Check elastic seal rings for defects.
- Oil in threads, sealing surfaces and contact surfaces except for ORFS-connections (ORFS = O-Ring Face Seal).

Applying Torque correction factor by tool angle

| Tool angle | Correction factor | |
|---------------------|-------------------|------------|
| | ORFS | Stud-end |
| Allowable tolerance | ±10% | - 0%, +10% |
| ±0° ~ ±30° | 5% over torque | |
| ±30° ~ ±45° | 20% over torque | |
| ±45° | NOT allowable | |

Tool access angle

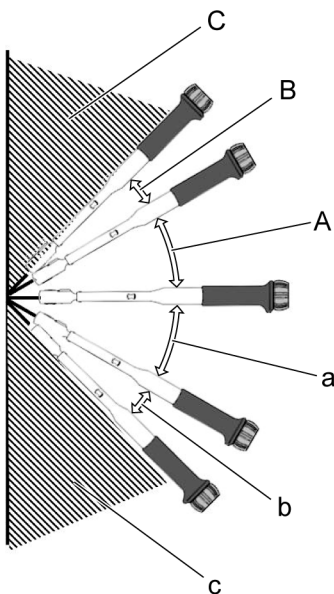

V1223202

Figure 1

Tool access angle

A: +0° ~ +30°

B: +30° ~ +45°

C: +45°

a: -0° ~ -30°

b: -30° ~ -45°

c: -45°

ORFS female swivel fitting

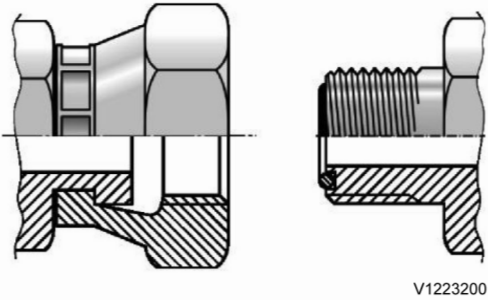

Figure 2

| Thread s type | Assembl y position | Threads | Standard torque | | ±0° ~ ±30° | | ±30° ~ ±45° | |
|------------------|-----------------------|------------------|-----------------|-------------|-------------|-------------|-------------|-------------|
| | | | (Nm) | (lbf ft) | (Nm) | (lbf ft) | (Nm) | (lbf ft) |
| UN- UNF | ORFS | UNF 9/16-18 | 29 ±3 | 21.4 ±2.2 | 30.5 ±3.1 | 22.1 ±2.2 | 36.5 ±3.7 | 26.9 ±2.7 |
| | | UN 11/16-16 | 44 ±4 | 32.5 ±3.0 | 46.2 ±4.6 | 34.1 ±3.4 | 55.4 ±5.5 | 40.9 ±4.1 |
| | | UN 13/16-16 | 63 ±6 | 46.5 ±4.4 | 66.2 ±6.6 | 48.8 ±4.9 | 79.4 ±7.9 | 58.6 ±5.9 |
| | | UNS 1-14 | 106 ±8 | 78.2 ±5.9 | 111.3 ±11.1 | 82.1 ±8.2 | 133.6 ±13.4 | 98.5 ±9.9 |
| | | UN 1 3/16-12 | 140 ±12 | 103.3 ±8.9 | 147.0 ±14.7 | 108.4 ±10.8 | 176.4 ±17.6 | 130.1 ±13.0 |
| | | UN 1 7/16-12 | 175 ±15 | 129.1 ±11.1 | 183.8 ±18.4 | 135.6 ±13.6 | 220.5 ±22.1 | 162.6 ±16.3 |
| | | UN 1 11/16-12 | 270 ±20 | 199.1 ±14.8 | 283.5 ±28.4 | 209.1 ±20.9 | 340.2 ±34.0 | 250.9 ±25.1 |
| | Stud-end | UNF 7/16-20 | 21 +2.1 | 15.4 +1.5 | 22.1 +2.2 | 16.3 +1.6 | 26.5 +2.7 | 19.5 +2.0 |
| | | UNF 1/2-20 | 37 +3.7 | 27.3 +2.7 | 38.9 +3.9 | 28.7 +2.9 | 46.6 +4.7 | 34.4 +3.4 |
| | | UNF 9/16-18 | 47 +4.7 | 34.7 +3.5 | 49.4 +4.9 | 36.4 +3.6 | 59.2 +5.9 | 43.7 +4.4 |
| | | UNF 3/4-16 | 81 +8.1 | 59.7 +6.0 | 85.1 +8.5 | 62.8 +6.3 | 102.1 +10.2 | 75.3 +7.5 |
| | | UNF 7/8-14 | 141 +14.1 | 104.0 +10.4 | 148.1 +14.8 | 109.2 +10.9 | 177.7 +17.8 | 131.1 +13.1 |
| | | UN 1 1/16-12 | 189 +18.9 | 139.4 +13.9 | 198.5 +19.9 | 146.4 +14.6 | 238.1 +23.8 | 175.6 +17.6 |
| | | UN 1 5/16-12 | 284 +28.4 | 209.5 +21.0 | 298.2 +29.8 | 219.9 +22.0 | 357.8 +35.8 | 263.9 +26.4 |
| UN 1 5/8-12 | 347 +34.7 | 255.9 +25.6 | 364.4 +36.4 | 268.8 +26.9 | 437.2 43.7 | 322.5 +32.3 | | |

| | | | | | | |
|----------------|-----------|-------------|-------------|-------------|-------------|-------------|
| UN 1 7/8-12 | 425 +42.5 | 313.5 +31.4 | 446.3 +44.6 | 329.2 +32.9 | 535.5 +53.6 | 395.0 +39.5 |
|----------------|-----------|-------------|-------------|-------------|-------------|-------------|

G thread 30° cone female swivel fitting

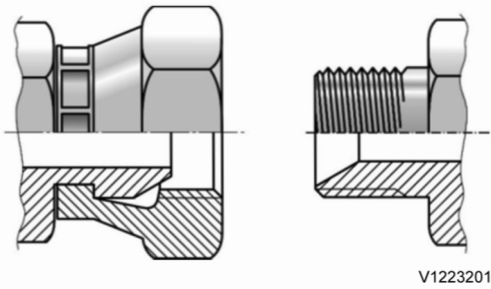

Figure 3

| Thread s type | Assembl y position | Threads | Standard torque | | ±0° ~ ±30° | | ±30° ~ ±45° | |
|------------------|--------------------------|-------------|-----------------|-------------|-------------|-------------|-------------|-------------|
| | | | (Nm) | (lbf ft) | (Nm) | (lbf ft) | (Nm) | (lbf ft) |
| PF | ORFS | G 1/4-19 | 25 ±2.5 | 18.4 ±1.8 | 26.3 ± 2.6 | 19.4 ±1.9 | 31.5 ±3.2 | 23.2 ±2.3 |
| | | G 3/8-19 | 49 ±4.9 | 36.1 ±3.6 | 51.5 ± 5.2 | 38.0 ±3.8 | 61.7 ±6.2 | 45.5 ±4.6 |
| | | G 1/2-14 | 59 ±5.9 | 43.5 ±4.4 | 62.0 ± 6.2 | 45.7 ±4.6 | 74.3 ±7.4 | 54.8 ±5.5 |
| | | G 3/4-11 | 119 ±11.9 | 87.8 ±8.8 | 125.0 ±12.5 | 92.2 ±9.2 | 149.9 ±15.0 | 110.6 ±11.1 |
| | | G 1-11 | 140 ±14 | 103.3 ±10.3 | 147.0 ±14.7 | 108.4 ±10.8 | 176.4 ±17.6 | 130.1 ±13.0 |
| | | G 1 1/4-11 | 173 ±17.3 | 127.6 ±12.8 | 181.7 ±18.2 | 134.0 ±13.4 | 218.0 ±21.8 | 160.8 ±16.1 |
| | | G 1 1/2-11 | 205 ±20.5 | 151.2 ±15.1 | 215.3 ±21.5 | 158.8 ±15.9 | 258.3 ±25.8 | 190.5 ±19.1 |
| | Stud-end | G 1/8-19 | 22 +2.2 | 16.2 +1.6 | 23.1 +2.3 | 17.0 +1.7 | 27.7 +2.8 | 20.4 +2.0 |
| | | G 1/4-19 | 52 +5.2 | 38.4 +3.8 | 54.6 +5.5 | 40.3 +4.0 | 65.5 +6.6 | 48.3 +4.8 |
| | | G 3/8-19 | 85 +8.5 | 62.7 +6.3 | 89.3 +8.9 | 65.9 +6.6 | 107.1 +10.7 | 79.0 +7.9 |
| | | G 1/2-14 | 105 +10.5 | 77.4 +7.7 | 110.3 +11.0 | 81.4 +8.1 | 132.3 +13.2 | 97.6 +9.8 |
| | | G 3/4-11 | 210 +21 | 154.9 +15.5 | 220.5 +22.1 | 162.6 +16.3 | 264.6 +26.5 | 195.2 +19.5 |
| | | G 1-11 | 400 +40 | 295.0 +29.5 | 420.0 +42.0 | 309.8 +31.0 | 504.0 +50.4 | 371.7 +37.1 |
| | | G 1 1/4-11 | 525 +52.5 | 387.2 +38.7 | 551.3 +55.1 | 406.6 +40.7 | 661.5 +66.2 | 487.9 +48.8 |
| G 1 1/2-11 | 630 +63.1 | 464.7 +46.5 | 661.5 +66.2 | 487.9 +48.8 | 793.8 +79.4 | 585.5 +58.6 | | |

| | | | |
|---|-------------------------------|---|---------------------------|
| Document Title: Measurement conversion tables | Function Group: 030 | Information Type: Service Information | Date: 8/14/2025 |
| Profile: EC210D Volvo | | | |

Measurement conversion tables

Showing Selected Profile

| Valid for serial numbers | | | |
|--------------------------|-----------------|---------------------|--------------------|
| Model | Production site | Serial number start | Serial number stop |
| EC210D Volvo | | | |

Length

| Unit | cm | m | km | in | ft | yd | mile |
|------|--------|--------|----------|---------|---------|---------|----------|
| cm | 1 | 0.01 | 0.00001 | 0.3937 | 0.03281 | 0.01094 | 0.000006 |
| m | 100 | 1 | 0.001 | 39.37 | 3.2808 | 1.0936 | 0.00062 |
| km | 100000 | 1000 | 1 | 39370.7 | 3280.8 | 1093.6 | 0.62137 |
| in | 2.54 | 0.0254 | 0.000025 | 1 | 0.08333 | 0.02777 | 0.000015 |
| ft | 30.48 | 0.3048 | 0.000304 | 12 | 1 | 0.3333 | 0.000189 |
| yd | 91.44 | 0.9144 | 0.000914 | 36 | 3 | 1 | 0.000568 |
| mile | 160930 | 1609.3 | 1.6093 | 63360 | 5280 | 1760 | 1 |

1 mm = 0.1 cm, 1 mm = 0.001 m

Area

| Unit | cm ² | m ² | km ² | a | ft ² | yd ² | in ² |
|-----------------|-----------------|----------------|-----------------|----------|-----------------|-----------------|-----------------|
| cm ² | 1 | 0.0001 | - | 0.000001 | 0.001076 | 0.000012 | 0.155000 |
| m ² | 10000 | 1 | 0.000001 | 0.01 | 10.764 | 1.1958 | 1550.000 |
| km ² | - | 1000000 | 1 | 10000 | 1076400 | 1195800 | - |
| a | 0.01 | 100 | 0.0001 | 1 | 1076.4 | 119.58 | - |
| ft ² | - | 0.092903 | - | 0.000929 | 1 | 0.1111 | 144.000 |
| yd ² | - | 0.83613 | - | 0.008361 | 9 | 1 | 1296.00 |
| in ² | 6.4516 | 0.000645 | - | - | 0.006943 | 0.000771 | 1 |

1 ha = 100 a, 1 mile² = 259 ha = 2.59 km²

Volume

| Unit | cm ³ = cc | m ³ | Liter | in ³ | ft ³ | yd ³ |
|---------------------------|----------------------|----------------|---------|-----------------|-----------------|-----------------|
| cm ³ = m liter | 1 | 0.000001 | 0.001 | 0.061024 | 0.000035 | 0.000001 |
| m ³ | 1000000 | 1 | 1000 | 61024 | 35.315 | 1.30796 |
| Liter | 1000 | 0.001 | 1 | 61.024 | 0.035315 | 0.001308 |
| in ³ | 16.387 | 0.000016 | 0.01638 | 1 | 0.000578 | 0.000021 |
| ft ³ | 28316.8 | 0.028317 | 28.317 | 1728 | 1 | 0.03704 |
| yd ³ | 764529.8 | 0.76453 | 764.53 | 46656 | 27 | 1 |

1 gal(US) = 3785.41 cm³ = 231 in³ = 0.83267 gal(UK)

Weight

| Unit | g | kg | t | oz | lb |
|------|---------|---------|----------|---------|---------|
| g | 1 | 0.001 | 0.000001 | 0.03527 | 0.0022 |
| kg | 1000 | 1 | 0.001 | 35.273 | 2.20459 |
| t | 1000000 | 1000 | 1 | 35273 | 2204.59 |
| oz | 28.3495 | 0.02835 | 0.000028 | 1 | 0.0625 |
| lb | 453.592 | 0.45359 | 0.000454 | 16 | 1 |

1 tonne(metric) = 1.1023 ton(US) = 0.9842 ton(UK)

Pressure

| Unit | kgf/cm ² | bar | Pa=N/m ² | kPa | lbf/in ² | lbf/ft ² |
|---------------------|---------------------|---------|---------------------|---------|---------------------|---------------------|
| kgf/cm ² | 1 | 0.98067 | 98066.5 | 98.0665 | 14.2233 | 2048.16 |
| bar | 1.01972 | 1 | 100000 | 100 | 14.5037 | 2088.6 |
| Pa=N/m ² | 0.00001 | 0.001 | 1 | 0.001 | 0.00015 | 0.02086 |
| kPa | 0.01020 | 0.01 | 1000 | 1 | 0.14504 | 20.886 |
| lbf/in ² | 0.07032 | 0.0689 | 6894.76 | 6.89476 | 1 | 144 |
| lbf/ft ² | 0.00047 | 0.00047 | 47.88028 | 0.04788 | 0.00694 | 1 |

1 kgf/cm² = 735.56 Torr(mmHg) = 0.96784 atm

Approximate conversions

| SI | Conversion | Non-SI | Conversion | SI |
|--|------------|------------------------|------------|--------------------------|
| Unit | Factor | Unit | Factor | Unit |
| Torque | | | | |
| newton meter (N·m) | x 10.2 | = kgf·cm | x 0.8664 | = (lbf·in) |
| newton meter (N·m) | x 0.74 | = lb·ft | x 1.36 | = N·m |
| newton meter (N·m) | x 0.102 | = kgf·m | x 7.22 | = (lbf·ft) |
| Pressure (Pa = N/m²) | | | | |
| kilopascal (kPa) | x 4.0 | = in. H ₂ O | x 0.249 | = kPa |
| kilopascal (kPa) | x 0.30 | = in. Hg | x 3.38 | = kPa |
| kilopascal (kPa) | x 0.145 | = psi | x 6.89 | = kPa |
| (bar) | x 14.5 | = psi | x 0.069 | = (bar) |
| (kgf/cm ²) | x 14.22 | = psi | x 0.070 | = (kgf/cm ²) |
| (newton/mm ²) | x 145.04 | = psi | x 0.069 | = (bar) |
| megapascal (MPa) | x 145 | = psi | x 0.00689 | = MPa |
| Power (W = J/s) | | | | |
| kilowatt (kW) | x 1.36 | = PS (cv) | x 0.736 | = kW |
| kilowatt (kW) | x 1.34 | = HP | x 0.746 | = kW |
| kilowatt (kW) | x 0.948 | = Btu/s | x 1.055 | = kW |
| watt (W) | x 0.74 | = ft·lb/s | x 1.36 | = W |

Note: () non-si unit

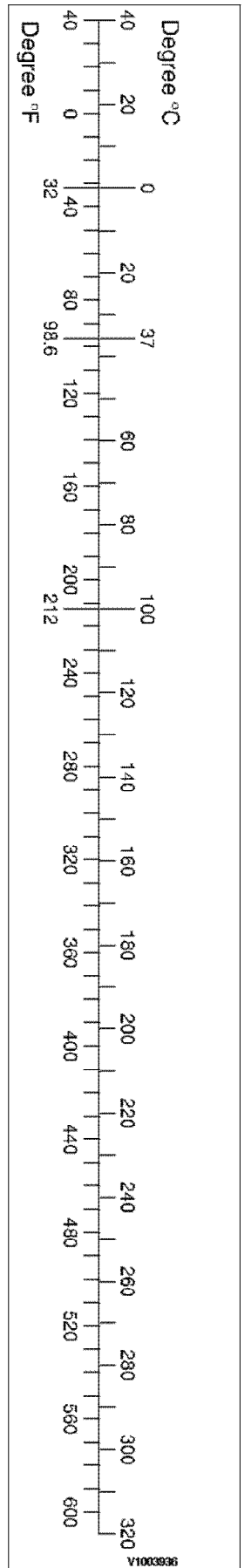

Approximate conversions

| SI Unit | Conversion Factor | Non-SI Unit | Conversion Factor | SI Unit |
|---------|-------------------|-------------|-------------------|---------|
| | | | | |

| | | | |
|--|-------------------------------|---|---------------------------|
| Document Title: Thermostat, specifications | Function Group: 030 | Information Type: Service Information | Date: 8/14/2025 |
| Profile: EC210D Volvo | | | |

Thermostat, specifications

Showing Selected Profile

| Valid for serial numbers | | | |
|--------------------------|-----------------|---------------------|--------------------|
| Model | Production site | Serial number start | Serial number stop |
| EC210D Volvo | | | |

| | |
|--------------------------------------|-------------------|
| Thermostat, type | Piston thermostat |
| Quantity | 1 |
| Coolant thermostat begins to open at | 83 °C (181 °F) |
| Coolant thermostat fully open at | 95 °C (302 °F) |
| Coolant thermostat stroke distance | 8 mm (0.32 in) |

| | | | |
|---|-------------------------------|---|---------------------------|
| Document Title: Operation numbers for additional work | Function Group: 070 | Information Type: Service Information | Date: 8/14/2025 |
| Profile: Excavators (EXC) | | | |

Operation numbers for additional work

Showing Selected Profile

These operations can be used to identify work that is not included in the time guide or described in the methods in the Service Manual. When these operations are used, a description of the work that has been performed must be provided.

Other work related to engine

Op. no. 070-210

This operation can be used when work has been done related to the engine and function group 2 when no applicable method description was available. When this operation is used, additional information is required:

- Description of work that has been done

Other work related to electrical system

Op. no. 070-310

This operation can be used when work has been done related to the electrical system and function group 3 when no applicable method description was available. When this operation is used, additional information is required:

- Description of work that has been done

Other work related to transmission, gearbox, travel motor, swing motor

Op. no. 070-410

This operation can be used when work has been done related to the transmission, gearbox, travel motor or swing motor and function group 4 when no applicable method description was available. When this operation is used, additional information is required:

- Description of work that has been done

Other work related to drive axle

Op. no. 070-470

This operation can be used when work has been done related to the drive axle and function group 46 when no applicable method description was available. When this operation is used, additional information is required:

- Description of required work that have been done

Other work related to brake system

Op. no. 070-510

This operation can be used when work has been done related to the brake system and function group 5 when no applicable

method description was available. When this operation is used, additional information is required:

- Description of work that has been done

Other work related to steering system

Op. no. 070-610

This operation can be used when work has been done related to the steering system and function group 6 when no applicable method description was available. When this operation is used, additional information is required:

- Description of work that has been done

Other work related to frame link, axle suspension

Op. no. 070-710

This operation can be used when work has been done related to the frame link, axle suspension and other parts related to function group 7 when no applicable method description was available. When this operation is used, additional information is required:

- Description of work that has been done

Other work related to cab, air conditioning

Op. no. 070-810

This operation can be used when work has been done related to the cab, air conditioning and other parts related to function group 8 when no applicable method description was available. When this operation is used, additional information is required:

- Description of work that has been done

Other work related to hydraulic system

Op. no. 070-910

This operation can be used when work has been done related to the hydraulic system and other parts related to function group 9 when no applicable method description was available. When this operation is used, additional information is required:

- Description of work that has been done

| | | | |
|---|-------------------------------|---|---------------------------|
| Document Title: E-tool, 3502 Plate for turning crankshaft | Function Group: 080 | Information Type: Service Information | Date: 8/14/2025 |
| Profile: EC210D Volvo | | | |

E-tool, 3502 Plate for turning crankshaft

Showing Selected Profile

| Valid for serial numbers | | | |
|--------------------------|-----------------|---------------------|--------------------|
| Model | Production site | Serial number start | Serial number stop |
| EC210D Volvo | | | |

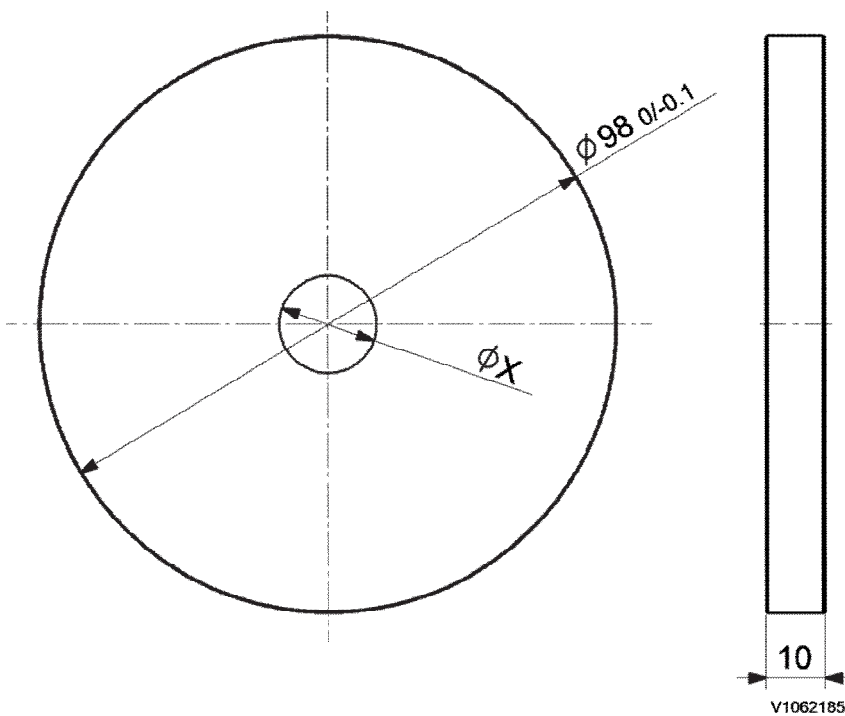

Figure 1

Support plate for engine valve clearance adjusting (unit: mm)

X: Shaft diameter of a ratchet extension

Material: Steel or plastic

| | | | |
|--|-------------------------------|---|---------------------------|
| Document Title: E-tools, NET 3004 Collar installation tool for track gearbox | Function Group: 080 | Information Type: Service Information | Date: 8/14/2025 |
| Profile: EC210D Volvo | | | |

E-tools, NET 3004 Collar installation tool for track gearbox

Showing Selected Profile

| Valid for serial numbers | | | |
|--------------------------|-----------------|---------------------|--------------------|
| Model | Production site | Serial number start | Serial number stop |
| EC210D Volvo | Shanghai | 230974 | 240000 |
| EC210D Volvo | Pederneiras | 240141 | 250000 |
| EC210D Volvo | Bangalore | 251804 | 280000 |
| EC210D Volvo | Changwon | 282821 | 310000 |

Track gearbox collar installation tool

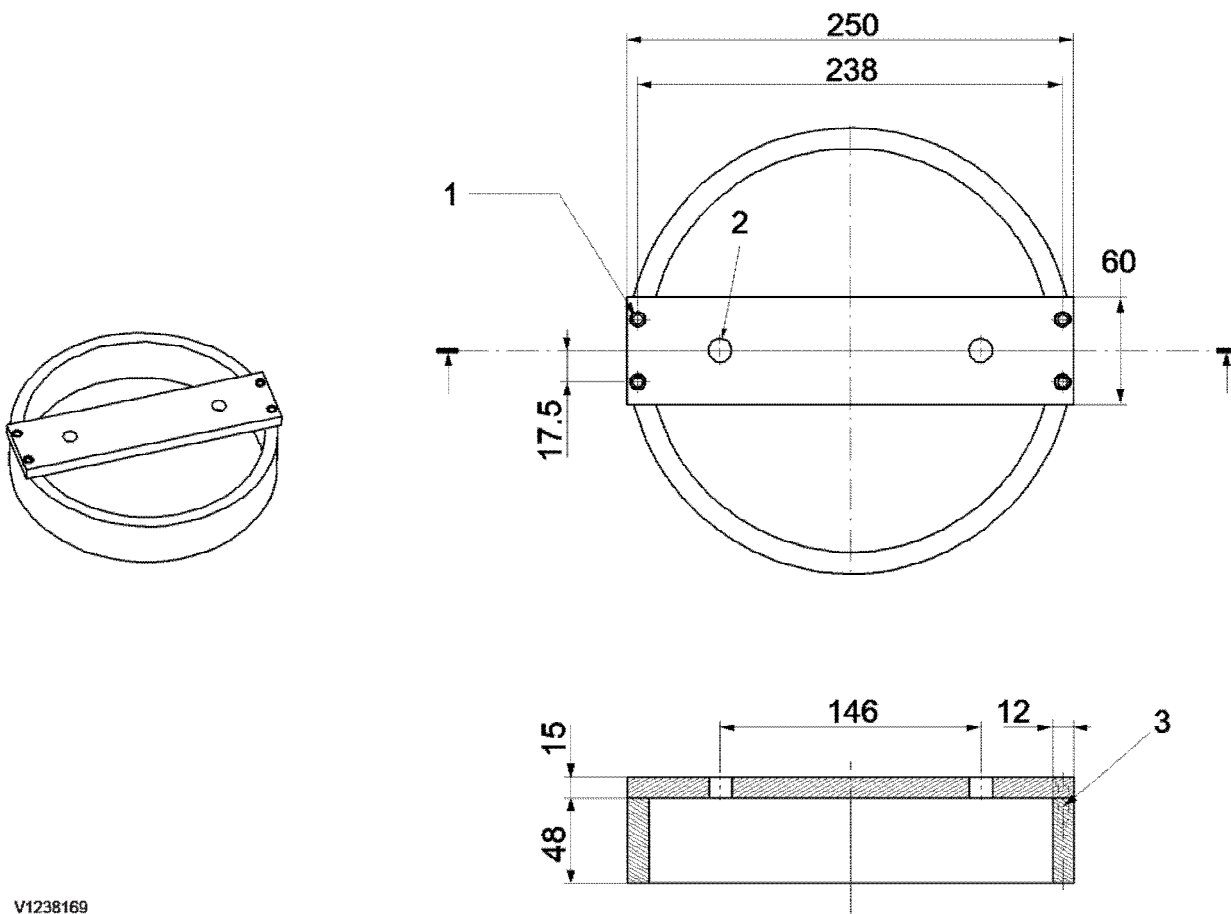

V1238169

Figure 1

Track gearbox collar installation tool (Unit; mm)

| Item | Quantity | Name | Remark |
|------|----------|------|--------|
|------|----------|------|--------|

| | | | |
|---|---|------------|----------------------------|
| 1 | 4 | Drill thru | 2x2x Ø5.5 Ø9 C'Bore DP6 |
| 2 | 2 | Drill thru | 2x Ø5.5 |
| 3 | 4 | Tap DP10 | 2x2x M5 |

| | | | |
|---|-------------------------------|---|---------------------------|
| Document Title: Service positions | Function Group: 091 | Information Type: Service Information | Date: 8/14/2025 |
| Profile: EC210D Volvo | | | |

Service positions

Showing Selected Profile

| Valid for serial numbers | | | |
|--------------------------|-----------------|---------------------|--------------------|
| Model | Production site | Serial number start | Serial number stop |
| EC210D Volvo | | | |

Park the machine on a horizontal and firm surface.
The suitable position is indicated in the description for the various service jobs.
Before beginning any work on the machine.

- Turn off the engine and remove the ignition key.
- Depressurize all pressurized lines and pressure vessels carefully so that high pressure is released without risk.
- Allow the machine to cool down.

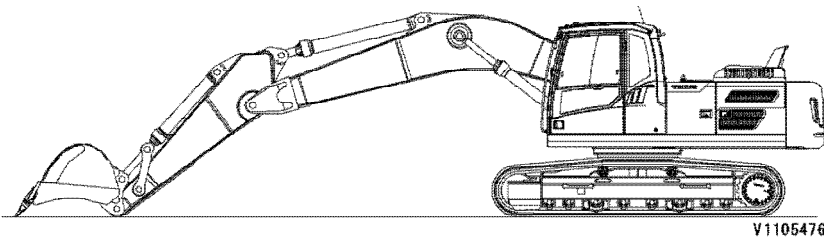

Figure 1
Service position A

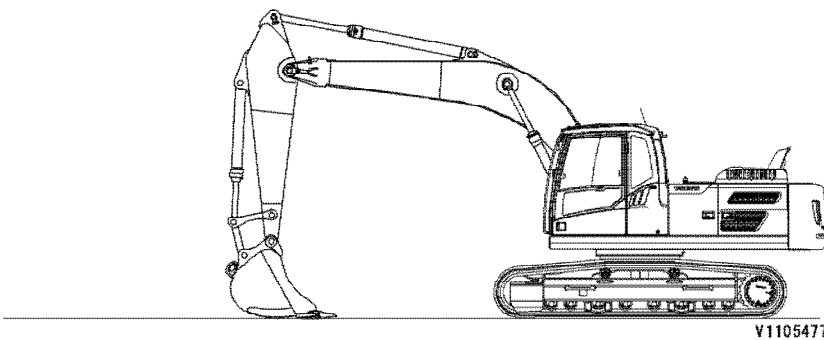

Figure 2
Service position B

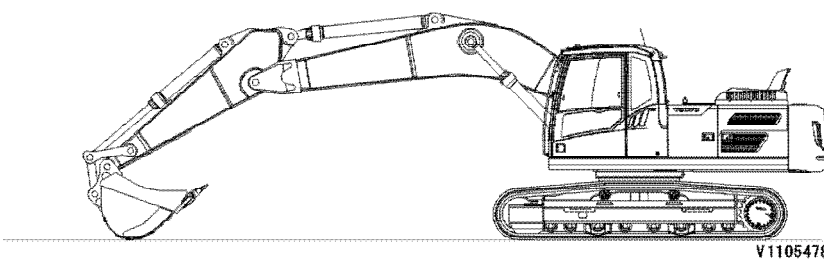

Figure 3
Service position C

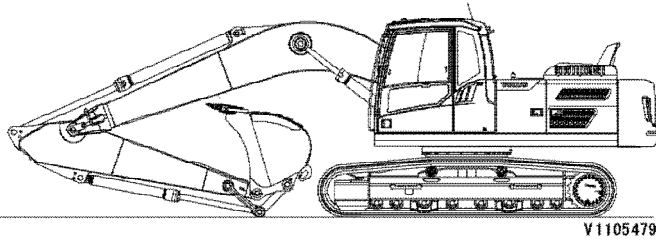

Figure 4
Service position D

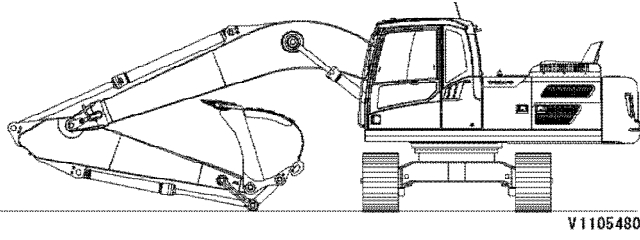

Figure 5
Service position E

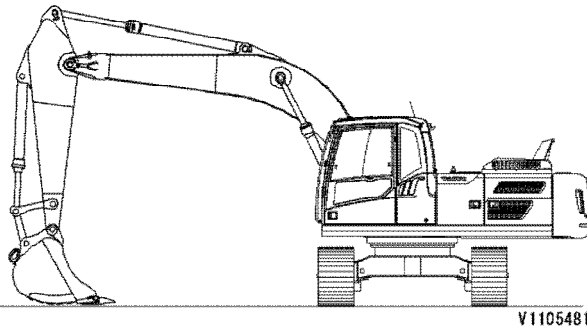

Figure 6
Service position F

| | | | |
|--|-------------------------------|---|---------------------------|
| Document Title: Welding on the machine | Function Group: 091 | Information Type: Service Information | Date: 8/14/2025 |
| Profile: EC210D Volvo | | | |

Welding on the machine

Showing Selected Profile

| Valid for serial numbers | | | |
|--------------------------|-----------------|---------------------|--------------------|
| Model | Production site | Serial number start | Serial number stop |
| EC210D Volvo | | | |

NOTICE

During electric welding on the machine or attachments connected to the machine, components such as bearings and electric units may be damaged if the ground cable is connected incorrectly.

The following actions should be taken before starting electric welding to eliminate these risks:

1. Turn off the electric power using the battery disconnect.
2. Disconnect the batteries.
NOTE!
Both the plus and minus terminal.
3. Disconnect the all electronic units.
 - General Purpose Machine Electronic Control Unit 1 (GPMECU1)
 - Human Machine Interface Control Unit (HMICU)
 - Engine Control Module (ECM)
 - Instrument Control (IC)
 - Climate Control Module (CCM)
 - Aftertreatment Control Module (ACM)
 - Telemetries Electronic Control Unit (WECU)
 - Key Pad 1
 - Key Pad 2
4. Connect the welding unit's ground connection as close as possible to the welding point, and make sure that the current does not pass across a bearing.

If welding is necessary on the boom or dipper arm, the following basic rules should be followed:

1. Welding beads should be laid down in the longitudinal direction.
2. If possible, weld in the middle of the metal section and never closer than **80 mm** to an edge.
3. Do not weld near the welded connections of the cylinder mounting eyes. Minimum distance from eye's weld to weld for weld lug = **100 mm**.
4. Do not weld close to where a metal plate has been bent.

| | | | |
|--|-------------------------------|---|---------------------------|
| Document Title: Hydraulic cylinders, dieseling | Function Group: 091 | Information Type: Service Information | Date: 8/14/2025 |
| Profile: EC210D Volvo | | | |

Hydraulic cylinders, dieseling

Showing Selected Profile

| Valid for serial numbers | | | |
|--------------------------|-----------------|---------------------|--------------------|
| Model | Production site | Serial number start | Serial number stop |
| EC210D Volvo | | | |

If air enters the hydraulic cylinders during work on the hydraulic system, this can lead to spontaneous ignition, an effect known as dieseling. This occurs if a favourable mixture of air and hydraulic oil is compressed when the piston approaches its end position in the cylinder. A sufficiently high temperature can be reached for the mixture to spontaneously ignite.

NOTICE

The dieseling effect may result in burnt piston seals and bushings.

In order to prevent dieseling, the lines for the hydraulic cylinders must be bled after work is completed, as follows:

1. No load and keep the lowest engine rpm
2. Operate the piston slowly up to the middle of cylinder in order to remove air from inner chamber of cylinder. Repeat over 5 times.
After that, operate the piston up to the end of cylinder in order to remove residual air from cylinder, pipe and hose gradually. Repeat over 5 times.

NOTICE

If the cylinders are pressurized either through lifting of the machine or lifting of a load in the bucket, without first performing the mentioned bleeding movements, the seals will likely be damaged.

If a cylinder is to be pressure-tested after a repair, the piston rod should be run in and out a few times before increasing the pressure to testing pressure.

| | | | |
|--|-------------------------------|---|---------------------------|
| Document Title: Recommended lubricants | Function Group: 160 | Information Type: Service Information | Date: 8/14/2025 |
| Profile: EC210D Volvo | | | |

[Go back to Index Page](#)

Recommended lubricants

Showing Selected Profile

| Valid for serial numbers | | | |
|--------------------------|-----------------|---------------------|--------------------|
| Model | Production site | Serial number start | Serial number stop |
| EC210D Volvo | | | |

The Volvo lubricants have been specially developed to fulfil the demanding operating conditions, in which Volvo excavators are used in. The oils have been tested according to Volvo excavator specifications and therefore meet the high requirements for safety and quality. Other mineral oils can be used if they conform to our viscosity recommendations and meet our quality requirements. The approval of Volvo is required, if any other oil base quality (for example biologically degradable oil) is to be used.

NOTE!

If a high water or excessive contamination in the lubricants (e.g. engine oil, hydraulic oil, axle oil, etc.) is found by Volvo oil analysis, change the lubricants regardless of the change interval.

See service bulletins "Oil sampling" in function group 160.

| System | Oil grade | Recommended viscosity at varying ambient temperature | | | | | | | | | | | | | | | | | | | | |
|----------------|--|--|-----|-----|-----|-----|-----|------|------|-----|-----|-----|----|-----|----|-----|-----|-----|-----|-----|------|------|
| Engine | Engine oil For detail, see page Engine oil . | <table border="1"> <tr> <td>°C</td> <td>-30</td> <td>-20</td> <td>-10</td> <td>0</td> <td>+10</td> <td>+20</td> <td>+30</td> <td>+40</td> <td>+50</td> </tr> <tr> <td>°F</td> <td>-22</td> <td>-4</td> <td>-14</td> <td>+32</td> <td>+50</td> <td>+68</td> <td>+86</td> <td>+104</td> <td>+122</td> </tr> </table> | °C | -30 | -20 | -10 | 0 | +10 | +20 | +30 | +40 | +50 | °F | -22 | -4 | -14 | +32 | +50 | +68 | +86 | +104 | +122 |
| °C | -30 | -20 | -10 | 0 | +10 | +20 | +30 | +40 | +50 | | | | | | | | | | | | | |
| °F | -22 | -4 | -14 | +32 | +50 | +68 | +86 | +104 | +122 | | | | | | | | | | | | | |
| Fuel | Diesel fuel For detail, see page Fuel . | <table border="1"> <tr> <td>°C</td> <td>-30</td> <td>-20</td> <td>-10</td> <td>0</td> <td>+10</td> <td>+20</td> <td>+30</td> <td>+40</td> <td>+50</td> </tr> <tr> <td>°F</td> <td>-22</td> <td>-4</td> <td>-14</td> <td>+32</td> <td>+50</td> <td>+68</td> <td>+86</td> <td>+104</td> <td>+122</td> </tr> </table> <p>NOTE! The fuel should at least meet the legal requirement, and national and international standards for marketed fuels, for example : EN590 (with nationally adapted temperature requirements), ASTM D975 No 1-D and No 2-D, JIS KK 2204.</p> | °C | -30 | -20 | -10 | 0 | +10 | +20 | +30 | +40 | +50 | °F | -22 | -4 | -14 | +32 | +50 | +68 | +86 | +104 | +122 |
| °C | -30 | -20 | -10 | 0 | +10 | +20 | +30 | +40 | +50 | | | | | | | | | | | | | |
| °F | -22 | -4 | -14 | +32 | +50 | +68 | +86 | +104 | +122 | | | | | | | | | | | | | |
| Cooling system | Volvo Coolant VCS Ready Mixed For detail, see page Coolant . | Volvo Coolant VCS Ready Mixed should be used only. NOTE! The content of Volvo coolant must not be less than 40% of the total mixture. | | | | | | | | | | | | | | | | | | | | |

*: Installed at factory

***: VDS-4 or VDS-4.5 approved oils only. Other oils can be used up to +30°C (86°F).

| System | Oil grade | Recommended viscosity at varying ambient temperature | | | | | | | | | | | | | | | | | | | | | | | | | | | | | | | | | | | | | | | | | | | | | | | | | |
|--|---|--|-----|-----|-----|-----|-----|------|------|------|-----|-----|-----|-----|-----|-----|-----|-----|-----|------|------|--------------|----------|--|--|--|--|--|--|--|--|-------------|--|--|--|--|--|--|--|--|--|-------------|--|--|--|--|--|--|--|--|--|
| Hydraulic system | Hydraulic oil for severe cold area or if siberian option kit is installed | <table border="1"> <tr> <td>°C</td> <td>-30</td> <td>-20</td> <td>-10</td> <td>0</td> <td>+10</td> <td>+20</td> <td>+30</td> <td>+40</td> <td>+50</td> </tr> <tr> <td>°F</td> <td>-22</td> <td>-4</td> <td>-14</td> <td>+32</td> <td>+50</td> <td>+68</td> <td>+86</td> <td>+104</td> <td>+122</td> </tr> <tr> <td colspan="10" style="text-align: center;">ISO VG15</td> </tr> </table> | °C | -30 | -20 | -10 | 0 | +10 | +20 | +30 | +40 | +50 | °F | -22 | -4 | -14 | +32 | +50 | +68 | +86 | +104 | +122 | ISO VG15 | | | | | | | | | | | | | | | | | | | | | | | | | | | | |
| | °C | -30 | -20 | -10 | 0 | +10 | +20 | +30 | +40 | +50 | | | | | | | | | | | | | | | | | | | | | | | | | | | | | | | | | | | | | | | | | |
| | °F | -22 | -4 | -14 | +32 | +50 | +68 | +86 | +104 | +122 | | | | | | | | | | | | | | | | | | | | | | | | | | | | | | | | | | | | | | | | | |
| | ISO VG15 | | | | | | | | | | | | | | | | | | | | | | | | | | | | | | | | | | | | | | | | | | | | | | | | | | |
| Volvo Hydraulic Oil 98609 Extra 46 or Volvo Hydraulic Oil 98609 Extra 68 | <table border="1"> <tr> <td>°C</td> <td>-30</td> <td>-20</td> <td>-10</td> <td>0</td> <td>+10</td> <td>+20</td> <td>+30</td> <td>+40</td> <td>+50</td> </tr> <tr> <td>°F</td> <td>-22</td> <td>-4</td> <td>-14</td> <td>+32</td> <td>+50</td> <td>+68</td> <td>+86</td> <td>+104</td> <td>+122</td> </tr> <tr> <td colspan="10" style="text-align: center;">ISO VG32 HV</td> </tr> <tr> <td colspan="10" style="text-align: center;">ISO VG46 HV</td> </tr> <tr> <td colspan="10" style="text-align: center;">ISO VG68 HV</td> </tr> </table> | °C | -30 | -20 | -10 | 0 | +10 | +20 | +30 | +40 | +50 | °F | -22 | -4 | -14 | +32 | +50 | +68 | +86 | +104 | +122 | ISO VG32 HV | | | | | | | | | | ISO VG46 HV | | | | | | | | | | ISO VG68 HV | | | | | | | | | |
| °C | -30 | -20 | -10 | 0 | +10 | +20 | +30 | +40 | +50 | | | | | | | | | | | | | | | | | | | | | | | | | | | | | | | | | | | | | | | | | | |
| °F | -22 | -4 | -14 | +32 | +50 | +68 | +86 | +104 | +122 | | | | | | | | | | | | | | | | | | | | | | | | | | | | | | | | | | | | | | | | | | |
| ISO VG32 HV | | | | | | | | | | | | | | | | | | | | | | | | | | | | | | | | | | | | | | | | | | | | | | | | | | | |
| ISO VG46 HV | | | | | | | | | | | | | | | | | | | | | | | | | | | | | | | | | | | | | | | | | | | | | | | | | | | |
| ISO VG68 HV | | | | | | | | | | | | | | | | | | | | | | | | | | | | | | | | | | | | | | | | | | | | | | | | | | | |
| Volvo Hydraulic Oil 98610 Biodegradable 46 | <table border="1"> <tr> <td>°C</td> <td>-30</td> <td>-20</td> <td>-10</td> <td>0</td> <td>+10</td> <td>+20</td> <td>+30</td> <td>+40</td> <td>+50</td> </tr> <tr> <td>°F</td> <td>-22</td> <td>-4</td> <td>-14</td> <td>+32</td> <td>+50</td> <td>+68</td> <td>+86</td> <td>+104</td> <td>+122</td> </tr> <tr> <td colspan="10" style="text-align: center;">Bio oil VG46</td> </tr> </table> <p>NOTE! If the machine is filled with Volvo Biodegradable hydraulic oil this oil must also be used when filling and changing. The mineral oil content in bio oil should not exceed 2% when changing from mineral oil to bio oil. Contact a workshop authorised by Volvo.</p> | °C | -30 | -20 | -10 | 0 | +10 | +20 | +30 | +40 | +50 | °F | -22 | -4 | -14 | +32 | +50 | +68 | +86 | +104 | +122 | Bio oil VG46 | | | | | | | | | | | | | | | | | | | | | | | | | | | | | |
| °C | -30 | -20 | -10 | 0 | +10 | +20 | +30 | +40 | +50 | | | | | | | | | | | | | | | | | | | | | | | | | | | | | | | | | | | | | | | | | | |
| °F | -22 | -4 | -14 | +32 | +50 | +68 | +86 | +104 | +122 | | | | | | | | | | | | | | | | | | | | | | | | | | | | | | | | | | | | | | | | | | |
| Bio oil VG46 | | | | | | | | | | | | | | | | | | | | | | | | | | | | | | | | | | | | | | | | | | | | | | | | | | | |
| Volvo Hydraulic Oil 98620 Ultra 46 (long life oil) or Volvo Hydraulic Oil 98620 Ultra 68 (long life oil) | <table border="1"> <tr> <td>°C</td> <td>-30</td> <td>-20</td> <td>-10</td> <td>0</td> <td>+10</td> <td>+20</td> <td>+30</td> <td>+40</td> <td>+50</td> </tr> <tr> <td>°F</td> <td>-22</td> <td>-4</td> <td>-14</td> <td>+32</td> <td>+50</td> <td>+68</td> <td>+86</td> <td>+104</td> <td>+122</td> </tr> <tr> <td colspan="10" style="text-align: center;">ISO VG32</td> </tr> <tr> <td colspan="10" style="text-align: center;">ISO VG46</td> </tr> <tr> <td colspan="10" style="text-align: center;">ISO VG68</td> </tr> </table> | °C | -30 | -20 | -10 | 0 | +10 | +20 | +30 | +40 | +50 | °F | -22 | -4 | -14 | +32 | +50 | +68 | +86 | +104 | +122 | ISO VG32 | | | | | | | | | | ISO VG46 | | | | | | | | | | ISO VG68 | | | | | | | | | |
| °C | -30 | -20 | -10 | 0 | +10 | +20 | +30 | +40 | +50 | | | | | | | | | | | | | | | | | | | | | | | | | | | | | | | | | | | | | | | | | | |
| °F | -22 | -4 | -14 | +32 | +50 | +68 | +86 | +104 | +122 | | | | | | | | | | | | | | | | | | | | | | | | | | | | | | | | | | | | | | | | | | |
| ISO VG32 | | | | | | | | | | | | | | | | | | | | | | | | | | | | | | | | | | | | | | | | | | | | | | | | | | | |
| ISO VG46 | | | | | | | | | | | | | | | | | | | | | | | | | | | | | | | | | | | | | | | | | | | | | | | | | | | |
| ISO VG68 | | | | | | | | | | | | | | | | | | | | | | | | | | | | | | | | | | | | | | | | | | | | | | | | | | | |

| System | Oil grade | Recommended viscosity at varying ambient temperature | | | | | | | | | | | | | | | | | | | | | | | | | | | | | | | | | | | | | | | | |
|----------------------------------|---|---|-----|-----|-----|-----|-----|------|------|------|-----|-----|----|-----|----|-----|-----|-----|-----|-----|------|------|----------------------------------|--|--|--|--|--|--|--|--|--|---------|--|--|--|--|--|--|--|--|--|
| Track gearbox | Volvo Axle Oil 80W-90 GL-5 or Volvo Axle Oil 85W-140 GL-5 or Volvo Axle Oil Volvo 97317 75W-80 GO102 or Volvo Axle Oil Limited Slip 85W-90 GL-5 | <table border="1"> <tr> <td>°C</td> <td>-30</td> <td>-20</td> <td>-10</td> <td>0</td> <td>+10</td> <td>+20</td> <td>+30</td> <td>+40</td> <td>+50</td> </tr> <tr> <td>°F</td> <td>-22</td> <td>-4</td> <td>-14</td> <td>+32</td> <td>+50</td> <td>+68</td> <td>+86</td> <td>+104</td> <td>+122</td> </tr> <tr> <td colspan="10" style="text-align: center;">*SAE 90</td> </tr> <tr> <td colspan="10" style="text-align: center;">SAE 140</td> </tr> </table> | °C | -30 | -20 | -10 | 0 | +10 | +20 | +30 | +40 | +50 | °F | -22 | -4 | -14 | +32 | +50 | +68 | +86 | +104 | +122 | *SAE 90 | | | | | | | | | | SAE 140 | | | | | | | | | |
| °C | | -30 | -20 | -10 | 0 | +10 | +20 | +30 | +40 | +50 | | | | | | | | | | | | | | | | | | | | | | | | | | | | | | | | |
| °F | | -22 | -4 | -14 | +32 | +50 | +68 | +86 | +104 | +122 | | | | | | | | | | | | | | | | | | | | | | | | | | | | | | | | |
| *SAE 90 | | | | | | | | | | | | | | | | | | | | | | | | | | | | | | | | | | | | | | | | | | |
| SAE 140 | | | | | | | | | | | | | | | | | | | | | | | | | | | | | | | | | | | | | | | | | | |
| Swing gearbox | Or corresponding gearbox oil below. | | | | | | | | | | | | | | | | | | | | | | | | | | | | | | | | | | | | | | | | | |
| PTO gearbox (EC950 only) | <ul style="list-style-type: none"> ○ Mobil SHC630 ○ Chevron Cetus HiPerSYN Oil 220 | | | | | | | | | | | | | | | | | | | | | | | | | | | | | | | | | | | | | | | | | |
| Swing ring gear (Bath and Ball) | Volvo Lithium Grease EP2 | <table border="1"> <tr> <td>°C</td> <td>-30</td> <td>-20</td> <td>-10</td> <td>0</td> <td>+10</td> <td>+20</td> <td>+30</td> <td>+40</td> <td>+50</td> </tr> <tr> <td>°F</td> <td>-22</td> <td>-4</td> <td>-14</td> <td>+32</td> <td>+50</td> <td>+68</td> <td>+86</td> <td>+104</td> <td>+122</td> </tr> <tr> <td colspan="10" style="text-align: center;">Multi purpose EP** grease NLGI 2</td> </tr> </table> <p>Or corresponding grease on lithium base with EP** additives and consistency NLGI class 2.</p> | °C | -30 | -20 | -10 | 0 | +10 | +20 | +30 | +40 | +50 | °F | -22 | -4 | -14 | +32 | +50 | +68 | +86 | +104 | +122 | Multi purpose EP** grease NLGI 2 | | | | | | | | | | | | | | | | | | | |
| °C | -30 | -20 | -10 | 0 | +10 | +20 | +30 | +40 | +50 | | | | | | | | | | | | | | | | | | | | | | | | | | | | | | | | | |
| °F | -22 | -4 | -14 | +32 | +50 | +68 | +86 | +104 | +122 | | | | | | | | | | | | | | | | | | | | | | | | | | | | | | | | | |
| Multi purpose EP** grease NLGI 2 | | | | | | | | | | | | | | | | | | | | | | | | | | | | | | | | | | | | | | | | | | |
| Pin and bushing | Ultra Grease Moly EP2 or Volvo Lithium Grease EP2[T1] ⓘ For detail, see page Grease . | <table border="1"> <tr> <td>°C</td> <td>-30</td> <td>-20</td> <td>-10</td> <td>0</td> <td>+10</td> <td>+20</td> <td>+30</td> <td>+40</td> <td>+50</td> </tr> <tr> <td>°F</td> <td>-22</td> <td>-4</td> <td>-14</td> <td>+32</td> <td>+50</td> <td>+68</td> <td>+86</td> <td>+104</td> <td>+122</td> </tr> <tr> <td colspan="10" style="text-align: center;">*ISO-L-XBCFB2</td> </tr> </table> <p>Or corresponding grease on lithium base with EP** additives and consistency NLGI class 2.</p> | °C | -30 | -20 | -10 | 0 | +10 | +20 | +30 | +40 | +50 | °F | -22 | -4 | -14 | +32 | +50 | +68 | +86 | +104 | +122 | *ISO-L-XBCFB2 | | | | | | | | | | | | | | | | | | | |
| °C | -30 | -20 | -10 | 0 | +10 | +20 | +30 | +40 | +50 | | | | | | | | | | | | | | | | | | | | | | | | | | | | | | | | | |
| °F | -22 | -4 | -14 | +32 | +50 | +68 | +86 | +104 | +122 | | | | | | | | | | | | | | | | | | | | | | | | | | | | | | | | | |
| *ISO-L-XBCFB2 | | | | | | | | | | | | | | | | | | | | | | | | | | | | | | | | | | | | | | | | | | |
| Air conditioner system | Refrigerant | HFC R134a | | | | | | | | | | | | | | | | | | | | | | | | | | | | | | | | | | | | | | | | |

[T1] Volvo Lithium Grease EP2 is not recommended when the ambient temperature is above 40 °C.

*: Installed at factory

** : Extreme Pressure

| | | | |
|--|-------------------------------|---|---------------------------|
| Document Title: Recommended lubricants | Function Group: 160 | Information Type: Service Information | Date: 8/14/2025 |
| Profile: EC210D Volvo | | | |

[Go back to Index Page](#)

Recommended lubricants

Showing Selected Profile

| Valid for serial numbers | | | |
|--------------------------|-----------------|---------------------|--------------------|
| Model | Production site | Serial number start | Serial number stop |
| EC210D Volvo | | | |

The Volvo lubricants have been specially developed to fulfil the demanding operating conditions, in which Volvo excavators are used in. The oils have been tested according to Volvo excavator specifications and therefore meet the high requirements for safety and quality. Other mineral oils can be used if they conform to our viscosity recommendations and meet our quality requirements. The approval of Volvo is required, if any other oil base quality (for example biologically degradable oil) is to be used.

NOTE!

If a high water or excessive contamination in the lubricants (e.g. engine oil, hydraulic oil, axle oil, etc.) is found by Volvo oil analysis, change the lubricants regardless of the change interval.

See service bulletins "Oil sampling" in function group 160.

| System | Oil grade | Recommended viscosity at varying ambient temperature | | | | | | | | | | | | | | | | | | | | |
|----------------|--|--|-----|-----|-----|-----|-----|------|------|-----|-----|-----|----|-----|----|-----|-----|-----|-----|-----|------|------|
| Engine | Engine oil For detail, see page Engine oil . | <table border="1"> <tr> <td>°C</td> <td>-30</td> <td>-20</td> <td>-10</td> <td>0</td> <td>+10</td> <td>+20</td> <td>+30</td> <td>+40</td> <td>+50</td> </tr> <tr> <td>°F</td> <td>-22</td> <td>-4</td> <td>+14</td> <td>+32</td> <td>+50</td> <td>+68</td> <td>+86</td> <td>+104</td> <td>+122</td> </tr> </table> | °C | -30 | -20 | -10 | 0 | +10 | +20 | +30 | +40 | +50 | °F | -22 | -4 | +14 | +32 | +50 | +68 | +86 | +104 | +122 |
| °C | -30 | -20 | -10 | 0 | +10 | +20 | +30 | +40 | +50 | | | | | | | | | | | | | |
| °F | -22 | -4 | +14 | +32 | +50 | +68 | +86 | +104 | +122 | | | | | | | | | | | | | |
| Fuel | Diesel fuel For detail, see page Fuel . | <table border="1"> <tr> <td>°C</td> <td>-30</td> <td>-20</td> <td>-10</td> <td>0</td> <td>+10</td> <td>+20</td> <td>+30</td> <td>+40</td> <td>+50</td> </tr> <tr> <td>°F</td> <td>-22</td> <td>-4</td> <td>+14</td> <td>+32</td> <td>+50</td> <td>+68</td> <td>+86</td> <td>+104</td> <td>+122</td> </tr> </table> <p>NOTE! The fuel should at least meet the legal requirement, and national and international standards for marketed fuels, for example : EN590 (with nationally adapted temperature requirements), ASTM D975 No 1-D and No 2-D, JIS KK 2204.</p> | °C | -30 | -20 | -10 | 0 | +10 | +20 | +30 | +40 | +50 | °F | -22 | -4 | +14 | +32 | +50 | +68 | +86 | +104 | +122 |
| °C | -30 | -20 | -10 | 0 | +10 | +20 | +30 | +40 | +50 | | | | | | | | | | | | | |
| °F | -22 | -4 | +14 | +32 | +50 | +68 | +86 | +104 | +122 | | | | | | | | | | | | | |
| Cooling system | Volvo Coolant VCS Ready Mixed For detail, see page Coolant . | Volvo Coolant VCS Ready Mixed should be used only. NOTE! The content of Volvo coolant must not be less than 40% of the total mixture. | | | | | | | | | | | | | | | | | | | | |

*: Installed at factory

***: VDS-4 or VDS-4.5 approved oils only. Other oils can be used up to +30°C (86°F).

| System | Oil grade | Recommended viscosity at varying ambient temperature | | | | | | | | | | | | | | | | | | | | | | | | | | | | | | | | | | | | | | | | | | | | | | | | | |
|---|---|--|-----|-----|-----|-----|-----|------|------|------|-----|-----|-----|-----|-----|-----|-----|-----|-----|------|------|--------------|----------|--|--|--|--|--|--|--|--|-------------|--|--|--|--|--|--|--|--|--|-------------|--|--|--|--|--|--|--|--|--|
| Hydraulic system | Hydraulic oil for severe cold area or if siberian option kit is installed | <table border="1"> <tr> <td>°C</td> <td>-30</td> <td>-20</td> <td>-10</td> <td>0</td> <td>+10</td> <td>+20</td> <td>+30</td> <td>+40</td> <td>+50</td> </tr> <tr> <td>°F</td> <td>-22</td> <td>-4</td> <td>+14</td> <td>+32</td> <td>+50</td> <td>+68</td> <td>+86</td> <td>+104</td> <td>+122</td> </tr> <tr> <td colspan="10" style="text-align: center;">ISO VG15</td> </tr> </table> | °C | -30 | -20 | -10 | 0 | +10 | +20 | +30 | +40 | +50 | °F | -22 | -4 | +14 | +32 | +50 | +68 | +86 | +104 | +122 | ISO VG15 | | | | | | | | | | | | | | | | | | | | | | | | | | | | |
| | °C | -30 | -20 | -10 | 0 | +10 | +20 | +30 | +40 | +50 | | | | | | | | | | | | | | | | | | | | | | | | | | | | | | | | | | | | | | | | | |
| | °F | -22 | -4 | +14 | +32 | +50 | +68 | +86 | +104 | +122 | | | | | | | | | | | | | | | | | | | | | | | | | | | | | | | | | | | | | | | | | |
| | ISO VG15 | | | | | | | | | | | | | | | | | | | | | | | | | | | | | | | | | | | | | | | | | | | | | | | | | | |
| Volvo Hydraulic Oil Volvo 98609 Extra 32 or Volvo Hydraulic Oil Volvo 98609 Extra 46 or Volvo Hydraulic Oil Volvo 98609 Extra 68 or Volvo Hydraulic Oil Volvo 98611 HO103 68 | <table border="1"> <tr> <td>°C</td> <td>-30</td> <td>-20</td> <td>-10</td> <td>0</td> <td>+10</td> <td>+20</td> <td>+30</td> <td>+40</td> <td>+50</td> </tr> <tr> <td>°F</td> <td>-22</td> <td>-4</td> <td>+14</td> <td>+32</td> <td>+50</td> <td>+68</td> <td>+86</td> <td>+104</td> <td>+122</td> </tr> <tr> <td colspan="10" style="text-align: center;">ISO VG32 HV</td> </tr> <tr> <td colspan="10" style="text-align: center;">ISO VG46 HV</td> </tr> <tr> <td colspan="10" style="text-align: center;">ISO VG68 HV</td> </tr> </table> | °C | -30 | -20 | -10 | 0 | +10 | +20 | +30 | +40 | +50 | °F | -22 | -4 | +14 | +32 | +50 | +68 | +86 | +104 | +122 | ISO VG32 HV | | | | | | | | | | ISO VG46 HV | | | | | | | | | | ISO VG68 HV | | | | | | | | | |
| °C | -30 | -20 | -10 | 0 | +10 | +20 | +30 | +40 | +50 | | | | | | | | | | | | | | | | | | | | | | | | | | | | | | | | | | | | | | | | | | |
| °F | -22 | -4 | +14 | +32 | +50 | +68 | +86 | +104 | +122 | | | | | | | | | | | | | | | | | | | | | | | | | | | | | | | | | | | | | | | | | | |
| ISO VG32 HV | | | | | | | | | | | | | | | | | | | | | | | | | | | | | | | | | | | | | | | | | | | | | | | | | | | |
| ISO VG46 HV | | | | | | | | | | | | | | | | | | | | | | | | | | | | | | | | | | | | | | | | | | | | | | | | | | | |
| ISO VG68 HV | | | | | | | | | | | | | | | | | | | | | | | | | | | | | | | | | | | | | | | | | | | | | | | | | | | |
| Volvo Hydraulic Oil Volvo 98610 Biodegradable 46 | <table border="1"> <tr> <td>°C</td> <td>-30</td> <td>-20</td> <td>-10</td> <td>0</td> <td>+10</td> <td>+20</td> <td>+30</td> <td>+40</td> <td>+50</td> </tr> <tr> <td>°F</td> <td>-22</td> <td>-4</td> <td>+14</td> <td>+32</td> <td>+50</td> <td>+68</td> <td>+86</td> <td>+104</td> <td>+122</td> </tr> <tr> <td colspan="10" style="text-align: center;">Bio oil VG46</td> </tr> </table> <p>NOTE! If the machine is filled with Volvo Biodegradable hydraulic oil this oil must also be used when filling and changing. The mineral oil content in bio oil should not exceed 2% when changing from mineral oil to bio oil. Contact a workshop authorised by Volvo.</p> | °C | -30 | -20 | -10 | 0 | +10 | +20 | +30 | +40 | +50 | °F | -22 | -4 | +14 | +32 | +50 | +68 | +86 | +104 | +122 | Bio oil VG46 | | | | | | | | | | | | | | | | | | | | | | | | | | | | | |
| °C | -30 | -20 | -10 | 0 | +10 | +20 | +30 | +40 | +50 | | | | | | | | | | | | | | | | | | | | | | | | | | | | | | | | | | | | | | | | | | |
| °F | -22 | -4 | +14 | +32 | +50 | +68 | +86 | +104 | +122 | | | | | | | | | | | | | | | | | | | | | | | | | | | | | | | | | | | | | | | | | | |
| Bio oil VG46 | | | | | | | | | | | | | | | | | | | | | | | | | | | | | | | | | | | | | | | | | | | | | | | | | | | |
| Volvo Hydraulic Oil Volvo 98620 Ultra 46 (long life oil) or Volvo Hydraulic Oil Volvo 98620 Ultra 68 (long life oil) | <table border="1"> <tr> <td>°C</td> <td>-30</td> <td>-20</td> <td>-10</td> <td>0</td> <td>+10</td> <td>+20</td> <td>+30</td> <td>+40</td> <td>+50</td> </tr> <tr> <td>°F</td> <td>-22</td> <td>-4</td> <td>+14</td> <td>+32</td> <td>+50</td> <td>+68</td> <td>+86</td> <td>+104</td> <td>+122</td> </tr> <tr> <td colspan="10" style="text-align: center;">ISO VG32</td> </tr> <tr> <td colspan="10" style="text-align: center;">ISO VG46</td> </tr> <tr> <td colspan="10" style="text-align: center;">ISO VG68</td> </tr> </table> | °C | -30 | -20 | -10 | 0 | +10 | +20 | +30 | +40 | +50 | °F | -22 | -4 | +14 | +32 | +50 | +68 | +86 | +104 | +122 | ISO VG32 | | | | | | | | | | ISO VG46 | | | | | | | | | | ISO VG68 | | | | | | | | | |
| °C | -30 | -20 | -10 | 0 | +10 | +20 | +30 | +40 | +50 | | | | | | | | | | | | | | | | | | | | | | | | | | | | | | | | | | | | | | | | | | |
| °F | -22 | -4 | +14 | +32 | +50 | +68 | +86 | +104 | +122 | | | | | | | | | | | | | | | | | | | | | | | | | | | | | | | | | | | | | | | | | | |
| ISO VG32 | | | | | | | | | | | | | | | | | | | | | | | | | | | | | | | | | | | | | | | | | | | | | | | | | | | |
| ISO VG46 | | | | | | | | | | | | | | | | | | | | | | | | | | | | | | | | | | | | | | | | | | | | | | | | | | | |
| ISO VG68 | | | | | | | | | | | | | | | | | | | | | | | | | | | | | | | | | | | | | | | | | | | | | | | | | | | |

| System | Oil grade | Recommended viscosity at varying ambient temperature | | | | | | | | | | | | | | | | | | | | | | | | | | | | | | | | | | | | | | | | |
|----------------------------------|---|--|-----|-----|-----|-----|-----|------|------|------|-----|-----|----|-----|----|-----|-----|-----|-----|-----|------|------|----------------------------------|--|--|--|--|--|--|--|--|--|---------|--|--|--|--|--|--|--|--|--|
| Track gearbox | Volvo Axle Oil 80W-90 GL-5 or Volvo Axle Oil 85W-140 GL-5 or Volvo Axle Oil Limited Slip 85W-90 GL-5 | <table border="1"> <tr> <td>°C</td> <td>-30</td> <td>-20</td> <td>-10</td> <td>0</td> <td>+10</td> <td>+20</td> <td>+30</td> <td>+40</td> <td>+50</td> </tr> <tr> <td>°F</td> <td>-22</td> <td>-4</td> <td>+14</td> <td>+32</td> <td>+50</td> <td>+68</td> <td>+86</td> <td>+104</td> <td>+122</td> </tr> <tr> <td colspan="10" style="text-align: center;">*SAE 90</td> </tr> <tr> <td colspan="10" style="text-align: center;">SAE 140</td> </tr> </table> <p>Or corresponding gearbox oil below.</p> <ul style="list-style-type: none"> ○ Mobil SHC630 ○ Chevron Cetus HiPerSYN Oil 220 | °C | -30 | -20 | -10 | 0 | +10 | +20 | +30 | +40 | +50 | °F | -22 | -4 | +14 | +32 | +50 | +68 | +86 | +104 | +122 | *SAE 90 | | | | | | | | | | SAE 140 | | | | | | | | | |
| °C | | -30 | -20 | -10 | 0 | +10 | +20 | +30 | +40 | +50 | | | | | | | | | | | | | | | | | | | | | | | | | | | | | | | | |
| °F | | -22 | -4 | +14 | +32 | +50 | +68 | +86 | +104 | +122 | | | | | | | | | | | | | | | | | | | | | | | | | | | | | | | | |
| *SAE 90 | | | | | | | | | | | | | | | | | | | | | | | | | | | | | | | | | | | | | | | | | | |
| SAE 140 | | | | | | | | | | | | | | | | | | | | | | | | | | | | | | | | | | | | | | | | | | |
| Swing gearbox | | | | | | | | | | | | | | | | | | | | | | | | | | | | | | | | | | | | | | | | | | |
| PTO gearbox (EC950 only) | | | | | | | | | | | | | | | | | | | | | | | | | | | | | | | | | | | | | | | | | | |
| Swing ring gear (Bath and Ball) | Volvo Lithium Grease EP2 | <table border="1"> <tr> <td>°C</td> <td>-30</td> <td>-20</td> <td>-10</td> <td>0</td> <td>+10</td> <td>+20</td> <td>+30</td> <td>+40</td> <td>+50</td> </tr> <tr> <td>°F</td> <td>-22</td> <td>-4</td> <td>+14</td> <td>+32</td> <td>+50</td> <td>+68</td> <td>+86</td> <td>+104</td> <td>+122</td> </tr> <tr> <td colspan="10" style="text-align: center;">Multi purpose EP** grease NLGI 2</td> </tr> </table> <p>Or corresponding grease on lithium base with EP** additives and consistency NLGI class 2.</p> | °C | -30 | -20 | -10 | 0 | +10 | +20 | +30 | +40 | +50 | °F | -22 | -4 | +14 | +32 | +50 | +68 | +86 | +104 | +122 | Multi purpose EP** grease NLGI 2 | | | | | | | | | | | | | | | | | | | |
| °C | -30 | -20 | -10 | 0 | +10 | +20 | +30 | +40 | +50 | | | | | | | | | | | | | | | | | | | | | | | | | | | | | | | | | |
| °F | -22 | -4 | +14 | +32 | +50 | +68 | +86 | +104 | +122 | | | | | | | | | | | | | | | | | | | | | | | | | | | | | | | | | |
| Multi purpose EP** grease NLGI 2 | | | | | | | | | | | | | | | | | | | | | | | | | | | | | | | | | | | | | | | | | | |
| Pin and bushing | Ultra Grease Moly EP2 or Volvo Lithium Grease EP2[T1] ⓘ For detail, see page Grease . | <table border="1"> <tr> <td>°C</td> <td>-30</td> <td>-20</td> <td>-10</td> <td>0</td> <td>+10</td> <td>+20</td> <td>+30</td> <td>+40</td> <td>+50</td> </tr> <tr> <td>°F</td> <td>-22</td> <td>-4</td> <td>+14</td> <td>+32</td> <td>+50</td> <td>+68</td> <td>+86</td> <td>+104</td> <td>+122</td> </tr> <tr> <td colspan="10" style="text-align: center;">*ISO-L-XBCFB2</td> </tr> </table> <p>Or corresponding grease on lithium base with EP** additives and consistency NLGI class 2.</p> | °C | -30 | -20 | -10 | 0 | +10 | +20 | +30 | +40 | +50 | °F | -22 | -4 | +14 | +32 | +50 | +68 | +86 | +104 | +122 | *ISO-L-XBCFB2 | | | | | | | | | | | | | | | | | | | |
| °C | -30 | -20 | -10 | 0 | +10 | +20 | +30 | +40 | +50 | | | | | | | | | | | | | | | | | | | | | | | | | | | | | | | | | |
| °F | -22 | -4 | +14 | +32 | +50 | +68 | +86 | +104 | +122 | | | | | | | | | | | | | | | | | | | | | | | | | | | | | | | | | |
| *ISO-L-XBCFB2 | | | | | | | | | | | | | | | | | | | | | | | | | | | | | | | | | | | | | | | | | | |
| Air conditioner system | Refrigerant | HFC R134a | | | | | | | | | | | | | | | | | | | | | | | | | | | | | | | | | | | | | | | | |

[T1] Volvo Lithium Grease EP2 is not recommended when the ambient temperature is above 40 °C.

*: Installed at factory

** : Extreme Pressure

| | | | |
|----------------------------------|-------------------------------|---|---------------------------|
| Document Title: Grease | Function Group: 160 | Information Type: Service Information | Date: 8/14/2025 |
| Profile: EC210D Volvo | | | |

Grease

Showing Selected Profile

| Valid for serial numbers | | | |
|--------------------------|-----------------|---------------------|--------------------|
| Model | Production site | Serial number start | Serial number stop |
| EC210D Volvo | | | |

Recommended grease for all digging equipment greasing points

| Manufacturer | Product name | |
|-------------------|-----------------------------|---------------------------|
| | Recommendations | Alternatives* |
| VOLVO | Ultra Grease Moly EP2 | Volvo Lithium Grease EP2 |
| CALTEX | Molytex EP2 | Multifak EP2 |
| GULF | Gulflex Moly EP | Gulfcrown EP2 |
| EXXONMOBIL | Beacon EP2 Moly | Beacon EP2 |
| SHELL | Retinax HDX2 / Alvania HDX2 | Retinax EP2 / Alvania EP2 |
| TOTAL | Multis MS2 | Multis EP2 |
| CASTROL | Pyro LM | Pyroplex Red |

* Alternatives are not recommended when the ambient temperature is above 40 °C.

Mixability of types of grease with different additives

| | Mixability of types of grease with additives | | | | | |
|--------------------------|--|---------|-----------------|-----------------|-------------------|------|
| | Lithium | Calcium | Lithium complex | Calcium complex | Aluminium complex | Clay |
| Lithium | √ | √ | √ | | | |
| Calcium | √ | √ | √ | | | √ |
| Lithium complex | √ | √ | √ | √ | | |
| Calcium complex | | | √ | √ | | |
| Aluminium complex | | | √ | | √ | |
| Clay | | √ | | | √ | √ |

√ : Acceptable

| | | | |
|---|-------------------------------|---|---------------------------|
| Document Title: Hydraulic oil | Function Group: 160 | Information Type: Service Information | Date: 8/14/2025 |
| Profile: EC210D Volvo | | | |

Hydraulic oil

Showing Selected Profile

| Valid for serial numbers | | | |
|--------------------------|-----------------|---------------------|--------------------|
| Model | Production site | Serial number start | Serial number stop |
| EC210D Volvo | | | |

Only use Volvo genuine hydraulic oil approved by Volvo Construction Equipment. Do not mix different brands of hydraulic oil as this can lead to damage in the hydraulic system.

For the hydraulic oil specification, see page [Recommended lubricants](#).

| | Ambient temperature | | | | | | | | | | | |
|------------------|---------------------|-----|-----|-----|-----|-----|-----|-----|-----|------|------|------|
| | °C | -40 | -30 | -20 | -10 | 0 | +10 | +20 | +30 | +40 | +50 | +60 |
| | °F | -40 | -22 | -4 | +14 | +32 | +50 | +68 | +86 | +104 | +122 | +140 |
| Oil grade | | (B) | | (A) | | | (C) | | | | | |
| | | | (B) | | (A) | | | (C) | | | | |
| | | | | (B) | | (A) | | | | | | |

(A) : Ambient temperature recommended for general use of hydraulic system and components.

(B) : Ambient temperature guide for machine operation from a hydraulic oil viewpoint only, it does not guarantee the completion machine for other conditions like engine starting performance. In this range a warming-up period is needed to obtain proper performance.

(C) : Ambient temperature range to operate machine under special conditions, not a recommendation for general use conditions.

Additional recommendation for severe cold areas

A field solution for severe cold condition of ambient temperature between -40°C and +20°C.

- Type : Anti-wear type hydraulic oil
- Viscosity characteristic

Viscosity index : More than 130

Kinematic Viscosity : Less than 5,000cSt at -40°C, More than 5.6cSt at +90°C

NOTE!

This value is approximately equivalent to ISO Viscosity grade #22.

NOTE!

It is minimum theoretical recommendation without the guarantee of machine condition.

NOTE!

If the machine is filled with biodegradable Volvo hydraulic oil, it is recommended to take regular oil samples. See service bulletin "Recommendations for Oil Sampling Intervals" in function group 160.

Sample of manual. Download All 2405 pages at:

<https://www.arepairmanual.com/downloads/volvo-ec210d-excavators-service-manual/>