

Document Title: Machine view	Function Group: 000	Information Type: Service Information	Date: 7/31/2025
Profile: EC200D Volvo			

Machine view

Showing Selected Profile

Valid for serial numbers			
Model	Production site	Serial number start	Serial number stop
EC200D Volvo			

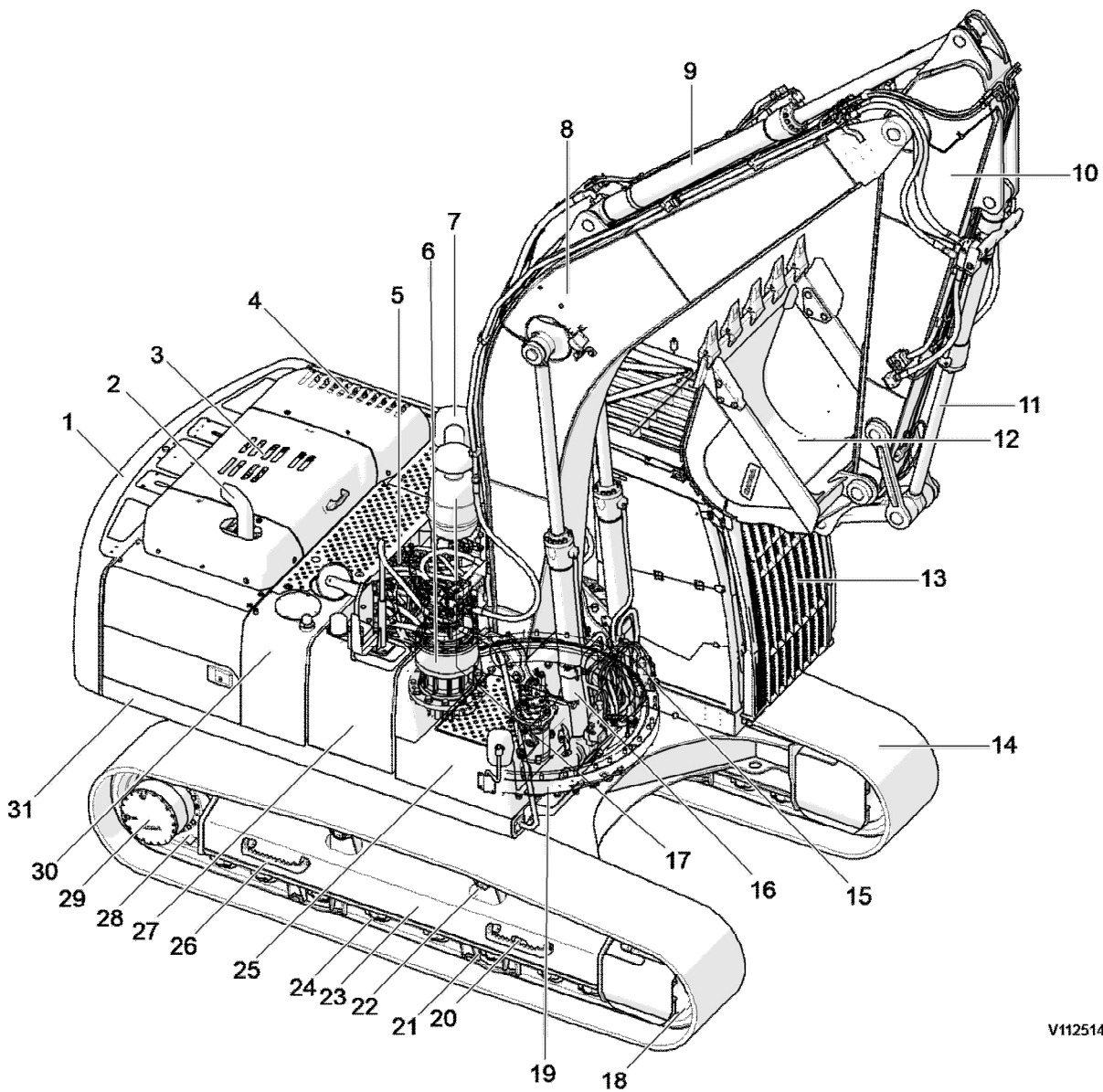

V1125143

Figure 1

The above illustration explains the case of the EC220D.

Product: Volvo EC200D Excavators Service Manual

Full Download: <https://www.arepairmanual.com/downloads/volvo-ec200d-excavators-service-manual/>

2	Muffler	18	Idler
3	Engine	19	Swing ring gear
4	Radiator and charge air cooler	20	Track tension grease valve
5	Main control valve	21	Track guard
6	Swing motor and gearbox	22	Top roller
7	Air cleaner	23	Lower frame
8	Boom	24	Bottom roller
9	Dipper arm cylinder	25	Battery
10	Dipper arm	26	Steps
11	Bucket cylinder	27	Fuel tank
12	Bucket	28	Sprocket
13	Operator's cab	29	Track motor and gearbox
14	Track chain	30	Hydraulic tank
15	Line rupture valves	31	Upper frame
16	Boom cylinder		

Sample of manual. Download All 2799 pages at:

<https://www.arepairmanual.com/downloads/volvo-ec200d-excavators-service-manual/>

Document Title: Product plates	Function Group: 000	Information Type: Service Information	Date: 7/31/2025
Profile: EC200D Volvo			

Product plates

Showing Selected Profile

Valid for serial numbers			
Model	Production site	Serial number start	Serial number stop
EC200D Volvo			

Please refer to the figure below to locate the product plate, engine plate, cab plate and attachment plates. Always use the Product Identification Number (PIN) provided on the vehicle and/or engine plates for troubleshooting purposes and/or when ordering spare parts.

1. Product plate

This plate with Product Identification Number, PIN, for the complete machine indicates the model designation, serial number and when applicable, machine weight, engine power, manufacturing year and CE approval. The plate is positioned on the right side of the upper frame.

Models (General application)

Volvo Crawler excavators and Wheel Excavator are available in different sizes from 5 ton to 95 ton. Some machines can be equipped with different Attachments, Demolition, High Reach Demolition, Pipe Layer, Rotating Pipelayer Kit machine and Dozer blade.

EC	Excavator Crawler	EW	Excavator Wheel
ECR	Excavator Crawler Short-Swing-Radius	AG	Agricultural machines
PL	Pipe Layer	FE	Feller Bunchers
L, LC	Long Crawler	NLD	Narrow Crawler Demolition
N, NC	Narrow Crawler	HR	High Reach Demolition
NL, NLC	Narrow Long Crawler	F, FX	Forestry Application
LM, LCM	Long Crawler Marsh	LD, LCD	Long Crawler Demolition
LR	Long Reach Boom & Arm	LC4	Long Crawler 4
LHDS	Long Crawler Heavy Duty Shanghai	LS	Long Crawler Shanghai
LHDC	Long Crawler Heavy Duty Changwon	NH	Narrow Heavy Duty
LRC4	Long Reach Crawler 4 (Boom & Arm)		

Supplementary PIN plate (EU countries only)

V	C	E	E	C	3	5	C	C	0	0	0	1	2	3	4	5
A			B				C		D							

V1076896

Figure 1

Example of 17 digit PIN number on PIN plate

- A. World Manufacturing Code
- B. Machine description
- C. Check letters
- D. Serial number

The supplementary plate contains information about machine mass in kg, engine net power in Kw, manufacturing year, machine serial number and a CE-mark.

Machine mass

The machine mass in kg on the supplementary PIN plate is based on:

- cab or canopy
- most used track type
- most usual bucket (without load)
- full fuel tank

For safety reasons, 103 % of the machine mass will be shown on the supplementary PIN plate.

2. Engine

The engine type designation, part and serial numbers are stamped on the top of valve cover.

3. Attachment quick coupler

This nameplate is attached on the outside of the bracket and indicates the part number and weight.

4. Bucket

This nameplate is attached on the top of the bucket and indicates the bucket model order number, serial number, bucket part number, rated capacity, weight, cutting width, tooth part number, and adapter part number.

5. Cab

The nameplate is attached on the inside of the cab and indicates the product number, serial number, model type, and weight.

Document Title: Volvo standard tightening torques	Function Group: 030	Information Type: Service Information	Date: 7/31/2025
Profile: EC200D Volvo			

Volvo standard tightening torques

Showing Selected Profile

Valid for serial numbers			
Model	Production site	Serial number start	Serial number stop
EC200D Volvo			

The tightening torques in the following tables apply to bolts and nuts with tensile strength. The tables should be used as a general instruction for tightening bolts and nuts without specified values. The charts contains values for course thread bolts and nuts.

Torque values should be increased with $\approx 10\%$, for flange bolts.

All standard torques for bolts are without surface treatment.

The standard torque for bolts lubricated with oil should be reduced with 20% of the given value.

Standard tightening torque charts

Bolt size Metric Coarse Threads	Tensile strength 8.8		Tensile strength 10.9	
	(Nm)	(lbf ft)	(Nm)	(lbf ft)
M5	6	4	8	6
M6	10	7	14	11
M8	25	18	35	26
M10	50	37	70	52
M12	87	64	122	90
M14	139	103	195	144
M16	213	157	299	220
M18	293	216	413	305
M20	416	307	585	432
M24	719	530	1010	745
M27	1060	782	1490	1100
M30	1140	840	2025	1493
M36	2500	1844	3600	2653

Bolt size Inch SAE Coarse Threads	Tensile strength 5		Tensile strength 8	
	(lbf ft)	(Nm)	(lbf ft)	(Nm)
1/4	10	13,6	14	19
5/16	21	28,5	29	39,3
3/8	37	50,2	52	70
7/16	59	80	84	114
1/2	90	122	128	174
9/16	130	176	184	250
5/8	180	244	254	345

3/4	320	434	451	612
7/8	515	700	728	988
1	775	1052	1091	1480
1 1/8	953	1290	1545	2100
1 1/4	1344	1823	2180	2960
1 3/8	1600	2170	2650	3600
1 1/2	2000	2714	3200	4340

Hydraulic connections, general

Before fitting pipe couplings, plugs and hoses:

- Make sure that the sealing surfaces are clean and free from pores or scratches.
- Check elastic seal rings for defects.
- Oil in threads, sealing surfaces and contact surfaces except for ORFS-connections (ORFS = O-Ring Face Seal).

Applying Torque correction factor by tool angle

Tool angle	Correction factor	
	ORFS	Stud-end
Allowable tolerance	±10%	- 0%, +10%
±0° ~ ±30°	5% over torque	
±30° ~ ±45°	20% over torque	
±45°	NOT allowable	

Tool access angle

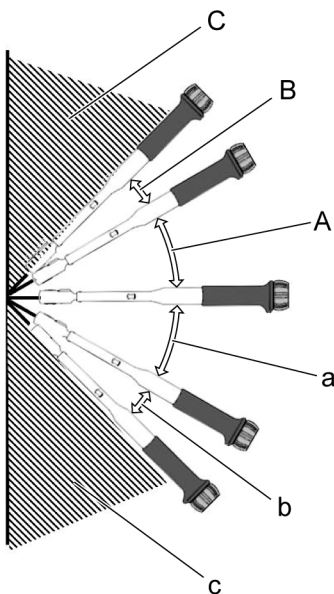

V1223202

Figure 1

Tool access angle

A: +0° ~ +30°

B: +30° ~ +45°

C: +45°

a: -0° ~ -30°

b: -30° ~ -45°

c: -45°

ORFS female swivel fitting

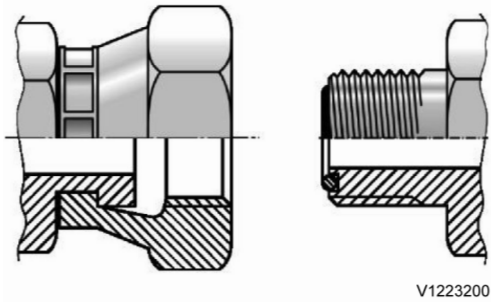

Figure 2

Thread s type	Assembl y position	Threads	Standard torque		±0° ~ ±30°		±30° ~ ±45°	
			(Nm)	(lbf ft)	(Nm)	(lbf ft)	(Nm)	(lbf ft)
UN- UNF	ORFS	UNF 9/16-18	29 ±3	21.4 ±2.2	30.5 ±3.1	22.1 ±2.2	36.5 ±3.7	26.9 ±2.7
		UN 11/16-16	44 ±4	32.5 ±3.0	46.2 ±4.6	34.1 ±3.4	55.4 ±5.5	40.9 ±4.1
		UN 13/16-16	63 ±6	46.5 ±4.4	66.2 ±6.6	48.8 ±4.9	79.4 ±7.9	58.6 ±5.9
		UNS 1-14	106 ±8	78.2 ±5.9	111.3 ±11.1	82.1 ±8.2	133.6 ±13.4	98.5 ±9.9
		UN 1 3/16-12	140 ±12	103.3 ±8.9	147.0 ±14.7	108.4 ±10.8	176.4 ±17.6	130.1 ±13.0
		UN 1 7/16-12	175 ±15	129.1 ±11.1	183.8 ±18.4	135.6 ±13.6	220.5 ±22.1	162.6 ±16.3
		UN 1 11/16-12	270 ±20	199.1 ±14.8	283.5 ±28.4	209.1 ±20.9	340.2 ±34.0	250.9 ±25.1
	Stud-end	UNF 7/16-20	21 +2.1	15.4 +1.5	22.1 +2.2	16.3 +1.6	26.5 +2.7	19.5 +2.0
		UNF 1/2-20	37 +3.7	27.3 +2.7	38.9 +3.9	28.7 +2.9	46.6 +4.7	34.4 +3.4
		UNF 9/16-18	47 +4.7	34.7 +3.5	49.4 +4.9	36.4 +3.6	59.2 +5.9	43.7 +4.4
		UNF 3/4-16	81 +8.1	59.7 +6.0	85.1 +8.5	62.8 +6.3	102.1 +10.2	75.3 +7.5
		UNF 7/8-14	141 +14.1	104.0 +10.4	148.1 +14.8	109.2 +10.9	177.7 +17.8	131.1 +13.1
		UN 1 1/16-12	189 +18.9	139.4 +13.9	198.5 +19.9	146.4 +14.6	238.1 +23.8	175.6 +17.6
		UN 1 5/16-12	284 +28.4	209.5 +21.0	298.2 +29.8	219.9 +22.0	357.8 +35.8	263.9 +26.4
UN 1 5/8-12	347 +34.7	255.9 +25.6	364.4 +36.4	268.8 +26.9	437.2 43.7	322.5 +32.3		

UN 1 7/8-12	425 +42.5	313.5 +31.4	446.3 +44.6	329.2 +32.9	535.5 +53.6	395.0 +39.5
----------------	-----------	-------------	-------------	-------------	-------------	-------------

G thread 30° cone female swivel fitting

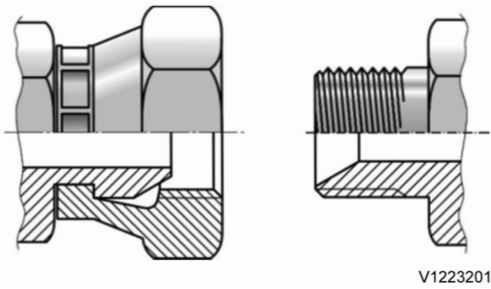

Figure 3

Thread s type	Assembl y position	Threads	Standard torque		±0° ~ ±30°		±30° ~ ±45°	
			(Nm)	(lbf ft)	(Nm)	(lbf ft)	(Nm)	(lbf ft)
PF	ORFS	G 1/4-19	25 ±2.5	18.4 ±1.8	26.3 ± 2.6	19.4 ±1.9	31.5 ±3.2	23.2 ±2.3
		G 3/8-19	49 ±4.9	36.1 ±3.6	51.5 ± 5.2	38.0 ±3.8	61.7 ±6.2	45.5 ±4.6
		G 1/2-14	59 ±5.9	43.5 ±4.4	62.0 ± 6.2	45.7 ±4.6	74.3 ±7.4	54.8 ±5.5
		G 3/4-11	119 ±11.9	87.8 ±8.8	125.0 ±12.5	92.2 ±9.2	149.9 ±15.0	110.6 ±11.1
		G 1-11	140 ±14	103.3 ±10.3	147.0 ±14.7	108.4 ±10.8	176.4 ±17.6	130.1 ±13.0
		G 1 1/4-11	173 ±17.3	127.6 ±12.8	181.7 ±18.2	134.0 ±13.4	218.0 ±21.8	160.8 ±16.1
		G 1 1/2-11	205 ±20.5	151.2 ±15.1	215.3 ±21.5	158.8 ±15.9	258.3 ±25.8	190.5 ±19.1
	Stud-end	G 1/8-19	22 +2.2	16.2 +1.6	23.1 +2.3	17.0 +1.7	27.7 +2.8	20.4 +2.0
		G 1/4-19	52 +5.2	38.4 +3.8	54.6 +5.5	40.3 +4.0	65.5 +6.6	48.3 +4.8
		G 3/8-19	85 +8.5	62.7 +6.3	89.3 +8.9	65.9 +6.6	107.1 +10.7	79.0 +7.9
		G 1/2-14	105 +10.5	77.4 +7.7	110.3 +11.0	81.4 +8.1	132.3 +13.2	97.6 +9.8
		G 3/4-11	210 +21	154.9 +15.5	220.5 +22.1	162.6 +16.3	264.6 +26.5	195.2 +19.5
		G 1-11	400 +40	295.0 +29.5	420.0 +42.0	309.8 +31.0	504.0 +50.4	371.7 +37.1
		G 1 1/4-11	525 +52.5	387.2 +38.7	551.3 +55.1	406.6 +40.7	661.5 +66.2	487.9 +48.8
G 1 1/2-11	630 +63.1	464.7 +46.5	661.5 +66.2	487.9 +48.8	793.8 +79.4	585.5 +58.6		

Document Title: Measurement conversion tables	Function Group: 030	Information Type: Service Information	Date: 7/31/2025
Profile: EC200D Volvo			

Measurement conversion tables

Showing Selected Profile

Valid for serial numbers			
Model	Production site	Serial number start	Serial number stop
EC200D Volvo			

Length

Unit	cm	m	km	in	ft	yd	mile
cm	1	0.01	0.00001	0.3937	0.03281	0.01094	0.000006
m	100	1	0.001	39.37	3.2808	1.0936	0.00062
km	100000	1000	1	39370.7	3280.8	1093.6	0.62137
in	2.54	0.0254	0.000025	1	0.08333	0.02777	0.000015
ft	30.48	0.3048	0.000304	12	1	0.3333	0.000189
yd	91.44	0.9144	0.000914	36	3	1	0.000568
mile	160930	1609.3	1.6093	63360	5280	1760	1

1 mm = 0.1 cm, 1 mm = 0.001 m

Area

Unit	cm ²	m ²	km ²	a	ft ²	yd ²	in ²
cm ²	1	0.0001	-	0.000001	0.001076	0.000012	0.155000
m ²	10000	1	0.000001	0.01	10.764	1.1958	1550.000
km ²	-	1000000	1	10000	1076400	1195800	-
a	0.01	100	0.0001	1	1076.4	119.58	-
ft ²	-	0.092903	-	0.000929	1	0.1111	144.000
yd ²	-	0.83613	-	0.008361	9	1	1296.00
in ²	6.4516	0.000645	-	-	0.006943	0.000771	1

1 ha = 100 a, 1 mile² = 259 ha = 2.59 km²

Volume

Unit	cm ³ = cc	m ³	Liter	in ³	ft ³	yd ³
cm ³ = m liter	1	0.000001	0.001	0.061024	0.000035	0.000001
m ³	1000000	1	1000	61024	35.315	1.30796
Liter	1000	0.001	1	61.024	0.035315	0.001308
in ³	16.387	0.000016	0.01638	1	0.000578	0.000021
ft ³	28316.8	0.028317	28.317	1728	1	0.03704
yd ³	764529.8	0.76453	764.53	46656	27	1

1 gal(US) = 3785.41 cm³ = 231 in³ = 0.83267 gal(UK)

Weight

Unit	g	kg	t	oz	lb
g	1	0.001	0.000001	0.03527	0.0022
kg	1000	1	0.001	35.273	2.20459
t	1000000	1000	1	35273	2204.59
oz	28.3495	0.02835	0.000028	1	0.0625
lb	453.592	0.45359	0.000454	16	1

1 tonne(metric) = 1.1023 ton(US) = 0.9842 ton(UK)

Pressure

Unit	kgf/cm ²	bar	Pa=N/m ²	kPa	lbf/in ²	lbf/ft ²
kgf/cm ²	1	0.98067	98066.5	98.0665	14.2233	2048.16
bar	1.01972	1	100000	100	14.5037	2088.6
Pa=N/m ²	0.00001	0.001	1	0.001	0.00015	0.02086
kPa	0.01020	0.01	1000	1	0.14504	20.886
lbf/in ²	0.07032	0.0689	6894.76	6.89476	1	144
lbf/ft ²	0.00047	0.00047	47.88028	0.04788	0.00694	1

1 kgf/cm² = 735.56 Torr(mmHg) = 0.96784 atm

Approximate conversions

SI	Conversion	Non-SI	Conversion	SI
Unit	Factor	Unit	Factor	Unit
Torque				
newton meter (N·m)	x 10.2	= kgf·cm	x 0.8664	= (lbf·in)
newton meter (N·m)	x 0.74	= lb·ft	x 1.36	= N·m
newton meter (N·m)	x 0.102	= kgf·m	x 7.22	= (lbf·ft)
Pressure (Pa = N/m²)				
kilopascal (kPa)	x 4.0	= in. H ₂ O	x 0.249	= kPa
kilopascal (kPa)	x 0.30	= in. Hg	x 3.38	= kPa
kilopascal (kPa)	x 0.145	= psi	x 6.89	= kPa
(bar)	x 14.5	= psi	x 0.069	= (bar)
(kgf/cm ²)	x 14.22	= psi	x 0.070	= (kgf/cm ²)
(newton/mm ²)	x 145.04	= psi	x 0.069	= (bar)
megapascal (MPa)	x 145	= psi	x 0.00689	= MPa
Power (W = J/s)				
kilowatt (kW)	x 1.36	= PS (cv)	x 0.736	= kW
kilowatt (kW)	x 1.34	= HP	x 0.746	= kW
kilowatt (kW)	x 0.948	= Btu/s	x 1.055	= kW
watt (W)	x 0.74	= ft·lb/s	x 1.36	= W

Note: () non-si unit

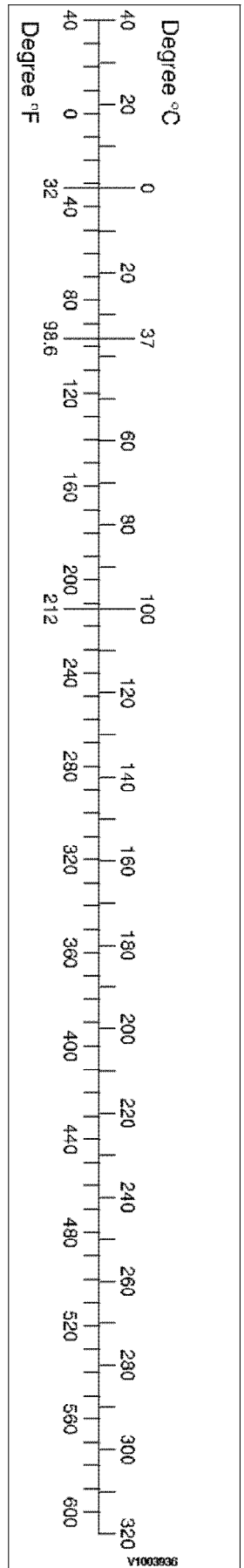

Approximate conversions

SI Unit	Conversion Factor	Non-SI Unit	Conversion Factor	SI Unit

Energy (J = N·m)				
kilojoule (kJ)	x 0.948	= Btu	x 1.055	= kJ
joule (J)	x 0.239	= calorie	x 4.19	= J
Velocity and Acceleration				
meter per sec ² (m/s ²)	x 3.28	= ft/s ²	x 0.305	= m/s ²
meter per sec (m/s)	x 3.28	= ft/s	x 0.305	= m/s
kilometer per hour (km/h)	x 0.62	= mph	x 1.61	= km/h
Horse power/torque				
BHP x 5252 rpm = TQ (lb·ft)			TQ x rpm 5252 = B.H.P.	
Temperature				
°C = (°F - 32) / 1.8		°F = (°C x 1.8) + 32		
Flow Rate				
liter/min (dm ³ /min)	x 0.264	= US gal/min x 3.785		= liter/min

Note: () non-si unit

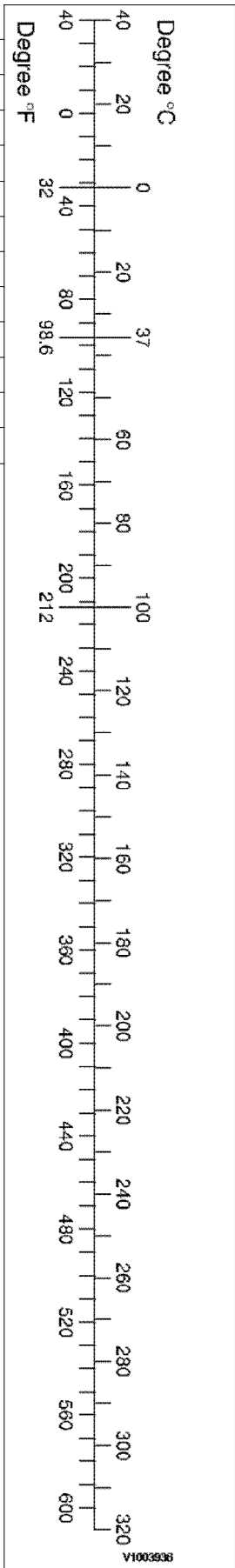

Document Title: Thermostat, specifications	Function Group: 030	Information Type: Service Information	Date: 7/31/2025
Profile: EC200D Volvo			

Thermostat, specifications

Showing Selected Profile

Valid for serial numbers			
Model	Production site	Serial number start	Serial number stop
EC200D Volvo			

Thermostat, type	Piston thermostat
Quantity	1
Coolant thermostat begins to open at	83 °C (181 °F)
Coolant thermostat fully open at	95 °C (302 °F)
Coolant thermostat stroke distance	8 mm (0.32 in)

Document Title: Operation numbers for additional work	Function Group: 070	Information Type: Service Information	Date: 7/31/2025
Profile: Excavators (EXC)			

Operation numbers for additional work

Showing Selected Profile

These operations can be used to identify work that is not included in the time guide or described in the methods in the Service Manual. When these operations are used, a description of the work that has been performed must be provided.

Other work related to engine

Op. no. 070-210

This operation can be used when work has been done related to the engine and function group 2 when no applicable method description was available. When this operation is used, additional information is required:

- Description of work that has been done

Other work related to electrical system

Op. no. 070-310

This operation can be used when work has been done related to the electrical system and function group 3 when no applicable method description was available. When this operation is used, additional information is required:

- Description of work that has been done

Other work related to transmission, gearbox, travel motor, swing motor

Op. no. 070-410

This operation can be used when work has been done related to the transmission, gearbox, travel motor or swing motor and function group 4 when no applicable method description was available. When this operation is used, additional information is required:

- Description of work that has been done

Other work related to drive axle

Op. no. 070-470

This operation can be used when work has been done related to the drive axle and function group 46 when no applicable method description was available. When this operation is used, additional information is required:

- Description of required work that have been done

Other work related to brake system

Op. no. 070-510

This operation can be used when work has been done related to the brake system and function group 5 when no applicable

method description was available. When this operation is used, additional information is required:

- Description of work that has been done

Other work related to steering system

Op. no. 070-610

This operation can be used when work has been done related to the steering system and function group 6 when no applicable method description was available. When this operation is used, additional information is required:

- Description of work that has been done

Other work related to frame link, axle suspension

Op. no. 070-710

This operation can be used when work has been done related to the frame link, axle suspension and other parts related to function group 7 when no applicable method description was available. When this operation is used, additional information is required:

- Description of work that has been done

Other work related to cab, air conditioning

Op. no. 070-810

This operation can be used when work has been done related to the cab, air conditioning and other parts related to function group 8 when no applicable method description was available. When this operation is used, additional information is required:

- Description of work that has been done

Other work related to hydraulic system

Op. no. 070-910

This operation can be used when work has been done related to the hydraulic system and other parts related to function group 9 when no applicable method description was available. When this operation is used, additional information is required:

- Description of work that has been done

Document Title: E-tools, NET 8940-00270 Replace tool for the swing ring gear	Function Group: 080	Information Type: Service Information	Date: 7/31/2025
Profile: EC200D Volvo			

E-tools, NET 8940-00270 Replace tool for the swing ring gear

Showing Selected Profile

Valid for serial numbers			
Model	Production site	Serial number start	Serial number stop
EC200D Volvo			

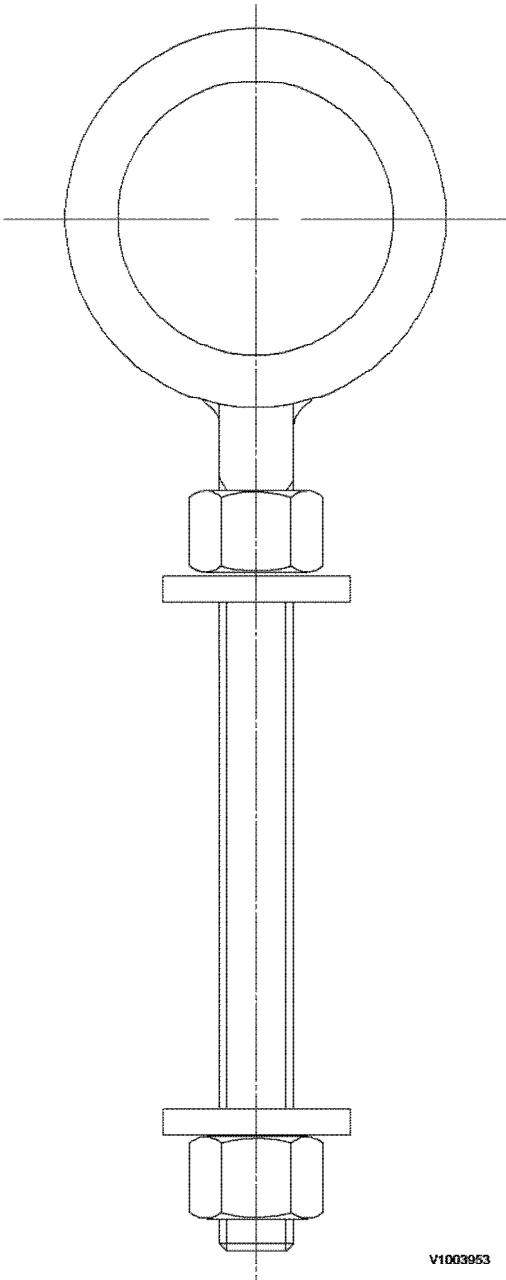

V1003953

Figure 1

Replace tool for the swing ring gear

Item	Quantity	Name	Remark
1	2	Ring	SAE 1045 (QT)
2	2	Round bar	SAE 1045 (QT)
3	4	Nut	M18
4	4	Washer	

Document Title: E-tools, NET 8940-00310 Replace tool for the swing ring gear	Function Group: 080	Information Type: Service Information	Date: 7/31/2025
Profile: EC200D Volvo			

E-tools, NET 8940-00310 Replace tool for the swing ring gear

Showing Selected Profile

Valid for serial numbers			
Model	Production site	Serial number start	Serial number stop
EC200D Volvo			

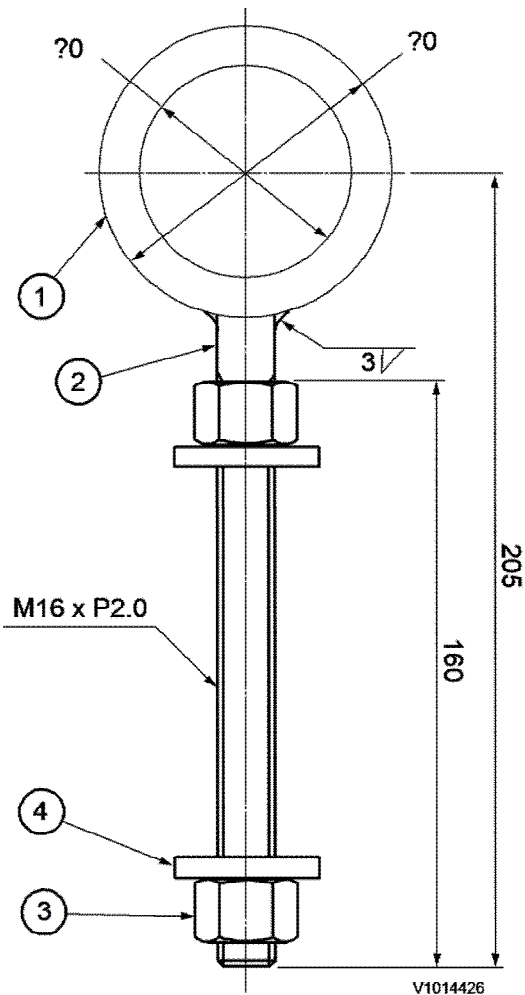

Figure 1

Replace tool for the swing ring gear

Item	Quantity	Name	Remark
1	2	Ring	SAE 1045 (QT)
2	2	Round bar ϕ 16	SAE 1045 (QT)
3	4	Nut	M16

4

4

Washer $\varphi 16 \times \varphi 35 \times 10$ t

Document Title: E-tools, NET 8940-00320 Swing motor guide pin and swing ring gear	Function Group: 080	Information Type: Service Information	Date: 7/31/2025
Profile: EC200D Volvo			

E-tools, NET 8940-00320 Swing motor guide pin and swing ring gear

Showing Selected Profile

Valid for serial numbers			
Model	Production site	Serial number start	Serial number stop
EC200D Volvo			

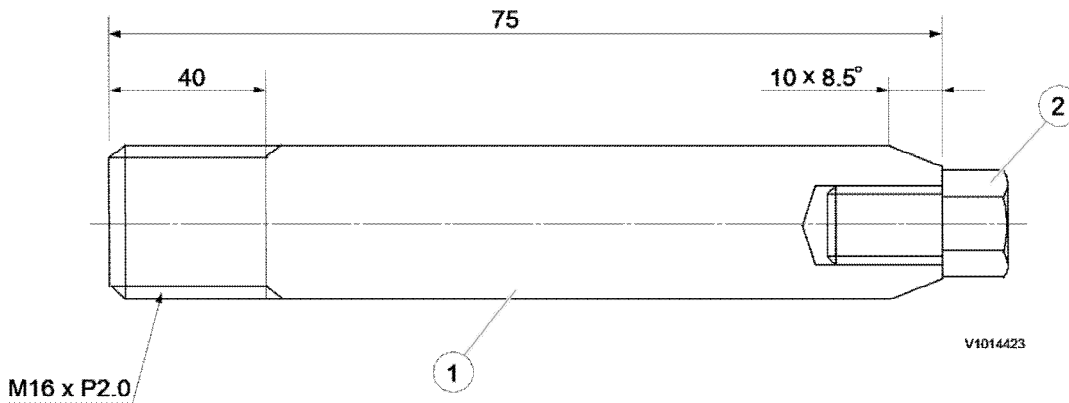

Figure 1
Swing motor guide pin

Item	Quantity	Name	Remark
1	2	Guide bar	SAE 4130 (25 ~ 35 HRC)
2	2	Screw	M8 x 1.0 x 16L

Document Title: E-tool, 3502 Plate for turning crankshaft	Function Group: 080	Information Type: Service Information	Date: 7/31/2025
Profile: EC200D Volvo			

E-tool, 3502 Plate for turning crankshaft

Showing Selected Profile

Valid for serial numbers			
Model	Production site	Serial number start	Serial number stop
EC200D Volvo			

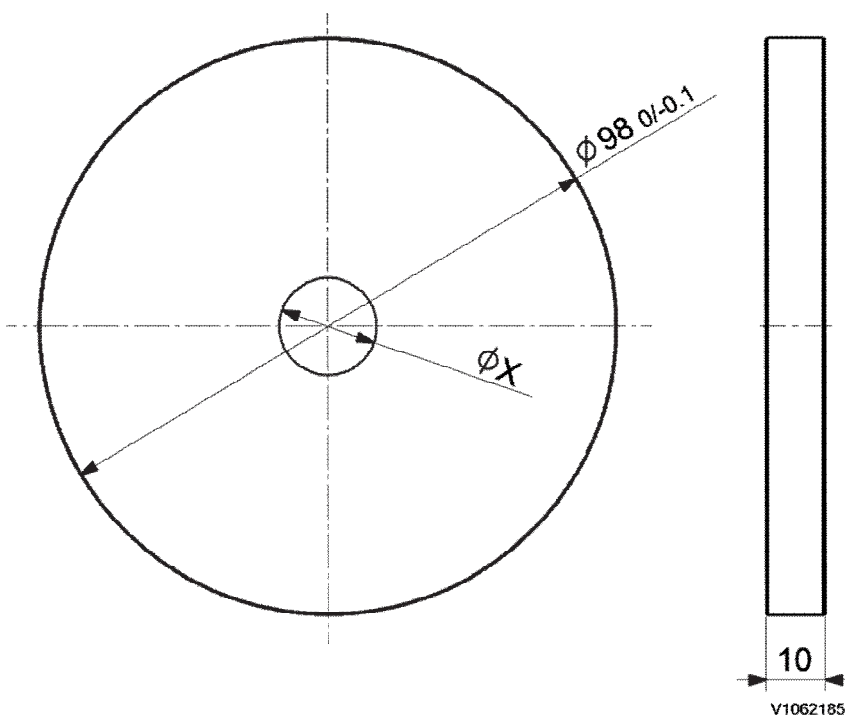

Figure 1

Support plate for engine valve clearance adjusting (unit: mm)

X: Shaft diameter of a ratchet extension

Material: Steel or plastic

Document Title: E-tools, NET 3004 Collar installation tool for track gearbox	Function Group: 080	Information Type: Service Information	Date: 7/31/2025
Profile: EC200D Volvo			

E-tools, NET 3004 Collar installation tool for track gearbox

Showing Selected Profile

Valid for serial numbers			
Model	Production site	Serial number start	Serial number stop
EC200D Volvo	Changwon	280011	310000

Track gearbox collar installation tool

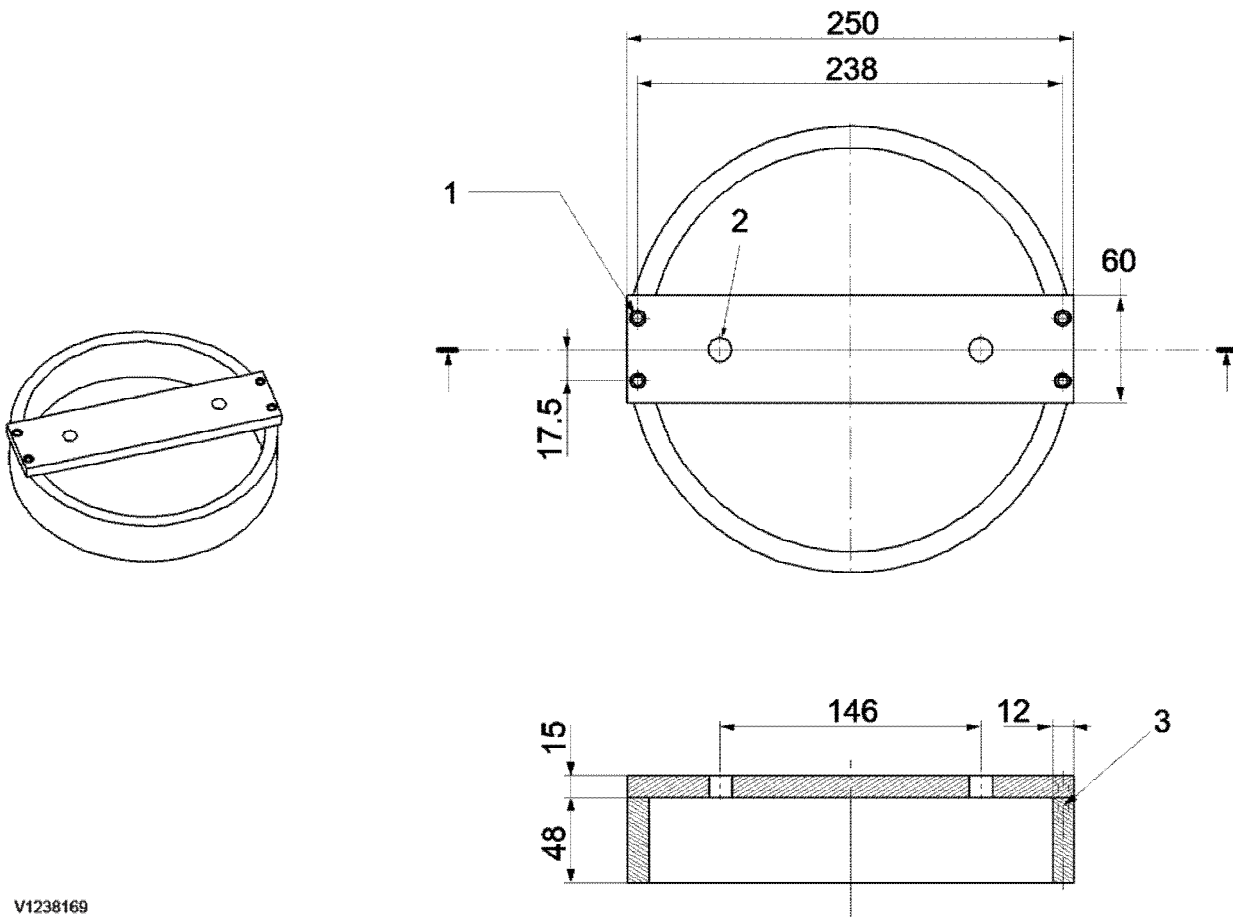

V1238169

Figure 1
Track gearbox collar installation tool (Unit; mm)

Item	Quantity	Name	Remark
1	4	Drill thru	2x2x Ø5.5 Ø9 C'Bore DP6
2	2	Drill thru	2x Ø5.5

3

4

Tap DP10

2x2x M5

Document Title: Service positions	Function Group: 091	Information Type: Service Information	Date: 7/31/2025
Profile: EC200D Volvo			

Service positions

Showing Selected Profile

Valid for serial numbers			
Model	Production site	Serial number start	Serial number stop
EC200D Volvo			

Park the machine on a horizontal and firm surface.
The suitable position is indicated in the description for the various service jobs.
Before beginning any work on the machine.

- Turn off the engine and remove the ignition key.
- Depressurize all pressurized lines and pressure vessels carefully so that high pressure is released without risk.
- Allow the machine to cool down.

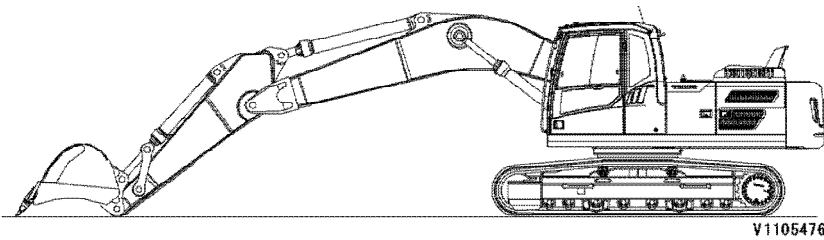

Figure 1
Service position A

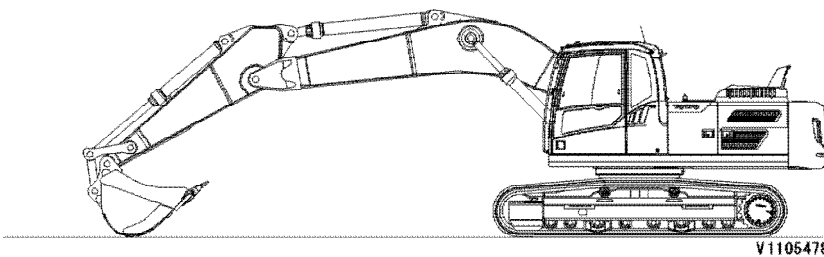

Figure 2
Service position B

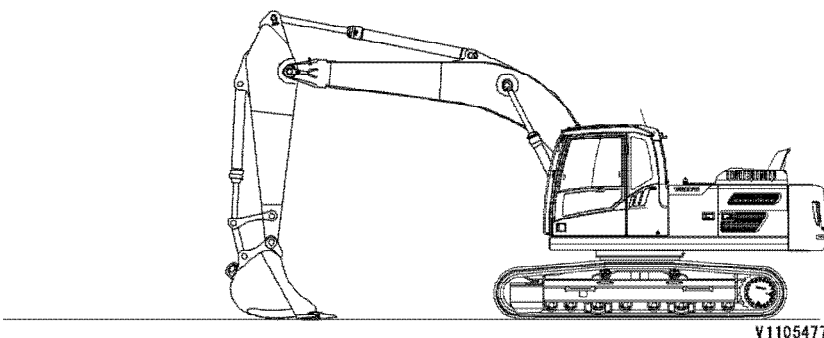

Figure 3
Service position C

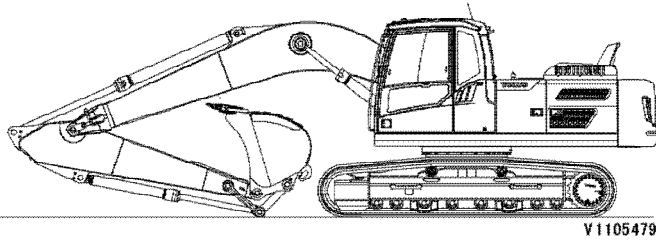

Figure 4
Service position D

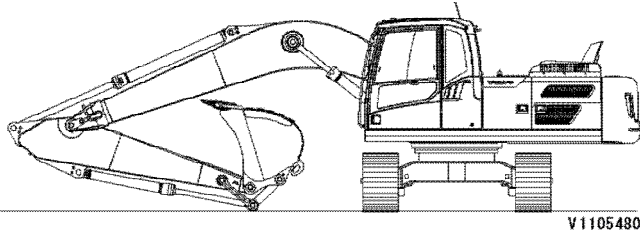

Figure 5
Service position E

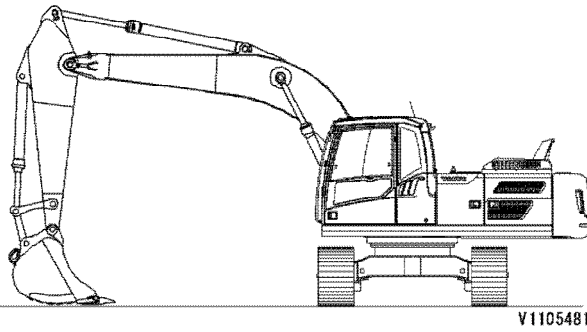

Figure 6
Service position F

Document Title: Welding on the machine	Function Group: 091	Information Type: Service Information	Date: 7/31/2025
Profile: EC200D Volvo			

Welding on the machine

Showing Selected Profile

Valid for serial numbers			
Model	Production site	Serial number start	Serial number stop
EC200D Volvo			

NOTICE

During electric welding on the machine or attachments connected to the machine, components such as bearings and electric units may be damaged if the ground cable is connected incorrectly.

The following actions should be taken before starting electric welding to eliminate these risks:

1. Turn off the electric power using the battery disconnect.
2. Disconnect the batteries.
NOTE!
Both the plus and minus terminal.
3. Disconnect the all electronic units.
 - General Purpose Machine Electronic Control Unit 1 (GPMECU1)
 - Human Machine Interface Control Unit (HMICU)
 - Engine Control Module (ECM)
 - Instrument Control (IC)
 - Climate Control Module (CCM)
 - Aftertreatment Control Module (ACM)
 - Telemetries Electronic Control Unit (WECU)
 - Key Pad 1
 - Key Pad 2
4. Connect the welding unit's ground connection as close as possible to the welding point, and make sure that the current does not pass across a bearing.

If welding is necessary on the boom or dipper arm, the following basic rules should be followed:

1. Welding beads should be laid down in the longitudinal direction.
2. If possible, weld in the middle of the metal section and never closer than **80 mm** to an edge.
3. Do not weld near the welded connections of the cylinder mounting eyes. Minimum distance from eye's weld to weld for weld lug = **100 mm**.
4. Do not weld close to where a metal plate has been bent.

Document Title: Hydraulic cylinders, dieseling	Function Group: 091	Information Type: Service Information	Date: 7/31/2025
Profile: EC200D Volvo			

Hydraulic cylinders, dieseling

Showing Selected Profile

Valid for serial numbers			
Model	Production site	Serial number start	Serial number stop
EC200D Volvo			

If air enters the hydraulic cylinders during work on the hydraulic system, this can lead to spontaneous ignition, an effect known as dieseling. This occurs if a favourable mixture of air and hydraulic oil is compressed when the piston approaches its end position in the cylinder. A sufficiently high temperature can be reached for the mixture to spontaneously ignite.

NOTICE

The dieseling effect may result in burnt piston seals and bushings.

In order to prevent dieseling, the lines for the hydraulic cylinders must be bled after work is completed, as follows:

1. No load and keep the lowest engine rpm
2. Operate the piston slowly up to the middle of cylinder in order to remove air from inner chamber of cylinder. Repeat over 5 times.
After that, operate the piston up to the end of cylinder in order to remove residual air from cylinder, pipe and hose gradually. Repeat over 5 times.

NOTICE

If the cylinders are pressurized either through lifting of the machine or lifting of a load in the bucket, without first performing the mentioned bleeding movements, the seals will likely be damaged.

If a cylinder is to be pressure-tested after a repair, the piston rod should be run in and out a few times before increasing the pressure to testing pressure.

Document Title: Recommended lubricants	Function Group: 160	Information Type: Service Information	Date: 7/31/2025
Profile: EC200D Volvo			

[Go back to Index Page](#)

Recommended lubricants

Showing Selected Profile

Valid for serial numbers			
Model	Production site	Serial number start	Serial number stop
EC200D Volvo	Changwon	280011	310000

The Volvo lubricants have been specially developed to fulfil the demanding operating conditions, in which Volvo excavators are used in. The oils have been tested according to Volvo excavator specifications and therefore meet the high requirements for safety and quality. Other mineral oils can be used if they conform to our viscosity recommendations and meet our quality requirements. The approval of Volvo is required, if any other oil base quality (for example biologically degradable oil) is to be used.

System	Oil grade	Recommended viscosity at varying ambient temperature																				
Engine	Engine oil see page Engine oil .	<table border="1"> <tr> <td>°C</td> <td>-30</td> <td>-20</td> <td>-10</td> <td>0</td> <td>+10</td> <td>+20</td> <td>+30</td> <td>+40</td> <td>+50</td> </tr> <tr> <td>°F</td> <td>-22</td> <td>-4</td> <td>-14</td> <td>+32</td> <td>+50</td> <td>+68</td> <td>+86</td> <td>+104</td> <td>+122</td> </tr> </table>	°C	-30	-20	-10	0	+10	+20	+30	+40	+50	°F	-22	-4	-14	+32	+50	+68	+86	+104	+122
°C	-30	-20	-10	0	+10	+20	+30	+40	+50													
°F	-22	-4	-14	+32	+50	+68	+86	+104	+122													
Track gearbox	Gear oil (with EP** additive) API GL4 or GL5	<table border="1"> <tr> <td>°C</td> <td>-30</td> <td>-20</td> <td>-10</td> <td>0</td> <td>+10</td> <td>+20</td> <td>+30</td> <td>+40</td> <td>+50</td> </tr> <tr> <td>°F</td> <td>-22</td> <td>-4</td> <td>-14</td> <td>+32</td> <td>+50</td> <td>+68</td> <td>+86</td> <td>+104</td> <td>+122</td> </tr> </table>	°C	-30	-20	-10	0	+10	+20	+30	+40	+50	°F	-22	-4	-14	+32	+50	+68	+86	+104	+122
°C	-30	-20	-10	0	+10	+20	+30	+40	+50													
°F	-22	-4	-14	+32	+50	+68	+86	+104	+122													
Swing gearbox	Gear oil (with EP** additive) API GL4 or GL5	<table border="1"> <tr> <td>°C</td> <td>-30</td> <td>-20</td> <td>-10</td> <td>0</td> <td>+10</td> <td>+20</td> <td>+30</td> <td>+40</td> <td>+50</td> </tr> <tr> <td>°F</td> <td>-22</td> <td>-4</td> <td>-14</td> <td>+32</td> <td>+50</td> <td>+68</td> <td>+86</td> <td>+104</td> <td>+122</td> </tr> </table>	°C	-30	-20	-10	0	+10	+20	+30	+40	+50	°F	-22	-4	-14	+32	+50	+68	+86	+104	+122
°C	-30	-20	-10	0	+10	+20	+30	+40	+50													
°F	-22	-4	-14	+32	+50	+68	+86	+104	+122													
Swing ring gear (Bath and Ball)	Grease	<table border="1"> <tr> <td>°C</td> <td>-30</td> <td>-20</td> <td>-10</td> <td>0</td> <td>+10</td> <td>+20</td> <td>+30</td> <td>+40</td> <td>+50</td> </tr> <tr> <td>°F</td> <td>-22</td> <td>-4</td> <td>-14</td> <td>+32</td> <td>+50</td> <td>+68</td> <td>+86</td> <td>+104</td> <td>+122</td> </tr> </table>	°C	-30	-20	-10	0	+10	+20	+30	+40	+50	°F	-22	-4	-14	+32	+50	+68	+86	+104	+122
°C	-30	-20	-10	0	+10	+20	+30	+40	+50													
°F	-22	-4	-14	+32	+50	+68	+86	+104	+122													

*: Installed at factory

** : Extreme Pressure

***: VDS-4 or VDS-4.5 approved oils only. Other oils can be used up to 30°C.

NOTE!

When starting the engine in an ambient temperature of lower than 0°C, be sure to use engine oil of SAE 5W-30, SAE 10W-30 and SAE 15W-40, even though the ambient temperature goes up to 10°C more or less in the day time.

System	Oil grade	Recommended viscosity at varying ambient temperature
--------	-----------	--

Hydraulic system	Volvo Extra hydraulic oil	<table border="1"> <thead> <tr> <th>°C</th> <th>-30</th> <th>-20</th> <th>-10</th> <th>0</th> <th>+10</th> <th>+20</th> <th>+30</th> <th>+40</th> <th>+50</th> </tr> <tr> <th>°F</th> <th>-22</th> <th>-4</th> <th>-14</th> <th>+32</th> <th>+50</th> <th>+68</th> <th>+86</th> <th>+104</th> <th>+122</th> </tr> </thead> <tbody> <tr> <td colspan="10" style="text-align: center;">ISO VG32 HV</td> </tr> <tr> <td colspan="10" style="text-align: center;">ISO VG46 HV</td> </tr> <tr> <td colspan="10" style="text-align: center;">ISO VG68 HV</td> </tr> </tbody> </table>	°C	-30	-20	-10	0	+10	+20	+30	+40	+50	°F	-22	-4	-14	+32	+50	+68	+86	+104	+122	ISO VG32 HV										ISO VG46 HV										ISO VG68 HV									
	°C	-30	-20	-10	0	+10	+20	+30	+40	+50																																										
°F	-22	-4	-14	+32	+50	+68	+86	+104	+122																																											
ISO VG32 HV																																																				
ISO VG46 HV																																																				
ISO VG68 HV																																																				
	Volvo Biodegradable hydraulic oil (based on synthetic ester)***	<table border="1"> <thead> <tr> <th>°C</th> <th>-30</th> <th>-20</th> <th>-10</th> <th>0</th> <th>+10</th> <th>+20</th> <th>+30</th> <th>+40</th> <th>+50</th> </tr> <tr> <th>°F</th> <th>-22</th> <th>-4</th> <th>-14</th> <th>+32</th> <th>+50</th> <th>+68</th> <th>+86</th> <th>+104</th> <th>+122</th> </tr> </thead> <tbody> <tr> <td colspan="10" style="text-align: center;">Bio oil VG46</td> </tr> </tbody> </table>	°C	-30	-20	-10	0	+10	+20	+30	+40	+50	°F	-22	-4	-14	+32	+50	+68	+86	+104	+122	Bio oil VG46																													
°C	-30	-20	-10	0	+10	+20	+30	+40	+50																																											
°F	-22	-4	-14	+32	+50	+68	+86	+104	+122																																											
Bio oil VG46																																																				
Pin and bushing	Grease (Multi purpose EP** grease NLGI 2)	<table border="1"> <thead> <tr> <th>°C</th> <th>-30</th> <th>-20</th> <th>-10</th> <th>0</th> <th>+10</th> <th>+20</th> <th>+30</th> <th>+40</th> <th>+50</th> </tr> <tr> <th>°F</th> <th>-22</th> <th>-4</th> <th>-14</th> <th>+32</th> <th>+50</th> <th>+68</th> <th>+86</th> <th>+104</th> <th>+122</th> </tr> </thead> <tbody> <tr> <td colspan="10" style="text-align: center;">*ISO-L-XBCFB2</td> </tr> </tbody> </table>	°C	-30	-20	-10	0	+10	+20	+30	+40	+50	°F	-22	-4	-14	+32	+50	+68	+86	+104	+122	*ISO-L-XBCFB2																													
°C	-30	-20	-10	0	+10	+20	+30	+40	+50																																											
°F	-22	-4	-14	+32	+50	+68	+86	+104	+122																																											
*ISO-L-XBCFB2																																																				
Fuel	Diesel fuel	<table border="1"> <thead> <tr> <th>°C</th> <th>-30</th> <th>-20</th> <th>-10</th> <th>0</th> <th>+10</th> <th>+20</th> <th>+30</th> <th>+40</th> <th>+50</th> </tr> <tr> <th>°F</th> <th>-22</th> <th>-4</th> <th>-14</th> <th>+32</th> <th>+50</th> <th>+68</th> <th>+86</th> <th>+104</th> <th>+122</th> </tr> </thead> <tbody> <tr> <td colspan="10" style="text-align: center;">ASTM D975 No.1</td> </tr> <tr> <td colspan="10" style="text-align: center;">*ASTM D975 No.2</td> </tr> </tbody> </table>	°C	-30	-20	-10	0	+10	+20	+30	+40	+50	°F	-22	-4	-14	+32	+50	+68	+86	+104	+122	ASTM D975 No.1										*ASTM D975 No.2																			
°C	-30	-20	-10	0	+10	+20	+30	+40	+50																																											
°F	-22	-4	-14	+32	+50	+68	+86	+104	+122																																											
ASTM D975 No.1																																																				
*ASTM D975 No.2																																																				
Cooling system	Volvo Coolant VCS	Volvo Coolant VCS should be used only, see page Coolant .																																																		
Air conditioner system	Refrigerant	HFC R134a																																																		

*: Installed at factory

** : Extreme Pressure

***: If the machine is filled with Volvo Biodegradable hydraulic oil this oil must also be used when filling and changing. The mineral oil content in bio oil should not exceed 2% when changing from mineral oil to bio oil. Contact a workshop authorised by Volvo.

NOTE!

The fuel should at least meet the legal requirement, and national and international standards for marketed fuels, for example : EN590 (with nationally adapted temperature requirements), ASTM D975 No 1-D and No 2-D, JIS KK 2204.

NOTE!

The content of Volvo coolant must not be less than 40% of the total mixture.

Document Title: Recommended lubricants	Function Group: 160	Information Type: Service Information	Date: 7/31/2025
Profile: EC200D Volvo, EC200D Volvo			

[Go back to Index Page](#)

Recommended lubricants

Showing Selected Profile

Valid for serial numbers			
Model	Production site	Serial number start	Serial number stop
EC200D Volvo	Shanghai	230001	280000
EC200D Volvo	Changwon	280011	310000

The Volvo lubricants have been specially developed to fulfil the demanding operating conditions, in which Volvo excavators are used in. The oils have been tested according to Volvo excavator specifications and therefore meet the high requirements for safety and quality. Other mineral oils can be used if they conform to our viscosity recommendations and meet our quality requirements. The approval of Volvo is required, if any other oil base quality (for example biologically degradable oil) is to be used.

NOTE!

If a high water or excessive contamination in the lubricants (e.g. engine oil, hydraulic oil, axle oil, etc.) is found by Volvo oil analysis, change the lubricants regardless of the change interval.

See service bulletins "Oil sampling" in function group 160.

System	Oil grade	Recommended viscosity at varying ambient temperature																				
Engine	Engine oil For detail, see page Engine oil .	<table border="1"> <tr> <td>°C</td> <td>-30</td> <td>-20</td> <td>-10</td> <td>0</td> <td>+10</td> <td>+20</td> <td>+30</td> <td>+40</td> <td>+50</td> </tr> <tr> <td>°F</td> <td>-22</td> <td>-4</td> <td>+14</td> <td>+32</td> <td>+50</td> <td>+68</td> <td>+86</td> <td>+104</td> <td>+122</td> </tr> </table>	°C	-30	-20	-10	0	+10	+20	+30	+40	+50	°F	-22	-4	+14	+32	+50	+68	+86	+104	+122
°C	-30	-20	-10	0	+10	+20	+30	+40	+50													
°F	-22	-4	+14	+32	+50	+68	+86	+104	+122													
Fuel	Diesel fuel For detail, see page Fuel .	<table border="1"> <tr> <td>°C</td> <td>-30</td> <td>-20</td> <td>-10</td> <td>0</td> <td>+10</td> <td>+20</td> <td>+30</td> <td>+40</td> <td>+50</td> </tr> <tr> <td>°F</td> <td>-22</td> <td>-4</td> <td>+14</td> <td>+32</td> <td>+50</td> <td>+68</td> <td>+86</td> <td>+104</td> <td>+122</td> </tr> </table> <p>NOTE! The fuel should at least meet the legal requirement, and national and international standards for marketed fuels, for example : EN590 (with nationally adapted temperature requirements), ASTM D975 No 1-D and No 2-D, JIS KK 2204.</p>	°C	-30	-20	-10	0	+10	+20	+30	+40	+50	°F	-22	-4	+14	+32	+50	+68	+86	+104	+122
°C	-30	-20	-10	0	+10	+20	+30	+40	+50													
°F	-22	-4	+14	+32	+50	+68	+86	+104	+122													
Cooling system	Volvo Coolant VCS-2 Ready Mixed For detail, see page Coolant .	Volvo Coolant VCS Ready Mixed should be used only. NOTE! The content of Volvo coolant must not be less than 40% of the total mixture.																				