

Document Title: <b>Description of machine</b>	Function Group: <b>000</b>	Information Type: <b>Service Information</b>	Date: <b>7/8/2025</b>
Profile:			

## Description of machine

The EC150C is a 360°-rotating tracked excavator with an operating weight of between 14.7 and 15.8 tonnes. The machine is equipped with a Volvo TD 40 KEE diesel engine. It is a water-cooled, four-cylinder, four-stroke, low-emission, direct-injected and turbocharged diesel engine which develops 78 kW net.

The engine drives the excavator's hydraulic system via a pump gearbox. In the standard version the pump gearbox has three pumps for the working hydraulics. A separate pump for the servo hydraulic circuit is mounted on the engine's cam transmission.

The machine has 3-circuit hydraulics with the Volvo-designed systems EXCELLENT and COS (= Capacity Optimized System). This enables all three pumps to be used for individual digging movements. Pump use is controlled by a Mode Selector with the following three programs:

HLD = Heavy Lift Device

ECO = Economy (low-speed travel)

CAP = Capacity (high-speed travel)

The pumps are controlled by PSC (Pressure Sensing Control) to prevent overloading of the diesel engine.

### Undercarriage

Propulsion of the machine takes place via 2-stage axial piston motors and planetary gears.

The planetary gearboxes are equipped with hydraulic brakes with negative action, i.e. they are applied by spring force and released by servo force.

The brakes are released when the pedals are activated

The brakes are of the multi-disc type in oil bath and are maintenance-free.

Rollers and front idlers are permanently lubricated.

### Superstructure

The superstructure is slewed by means of an axial piston motor via a gearbox with slewing pinion.

The gearbox is equipped with a hydraulic slewing brake with negative action, i.e. it is applied by spring force and released by servo pressure. The slewing pinion drives against a slewing ring with inner toothed rim.

The slewing ring joins the superstructure to the undercarriage. A centre passage connects the superstructure to the undercarriage hydraulically. The purpose of the centre passage is to supply the hydraulic components in the undercarriage with hydraulic oil flow from the pumps.

### Cab

The cab has a ventilation filter and is prepared for air conditioning.

### Electrical system

The machine has a computerized monitoring system for e.g. the diesel engine and hydraulic system.

Above the batteries, under the operator's seat, is an electrical distribution box (A2) where most of the fuses and relays are located.

### Digging equipment

The digging equipment is attached to the superstructure's boom hinge. The boom cylinder movement has a float position function. The boom cylinder is equipped with a hose rupture valve.

Different combinations of boom, dipper arm and attachment can be offered. This manual describes the most common standard alternatives.

Document Title: <b>Nameplates and their location</b>	Function Group: <b>000</b>	Information Type: <b>Service Information</b>	Date: <b>7/8/2025</b>
Profile:			

## Nameplates and their location

Pictures and texts show which nameplates and markings are on the machine.

When ordering spare parts and making inquiries by telephone and in correspondence, always state model designation and serial number.

State also any data stamped on individual parts.

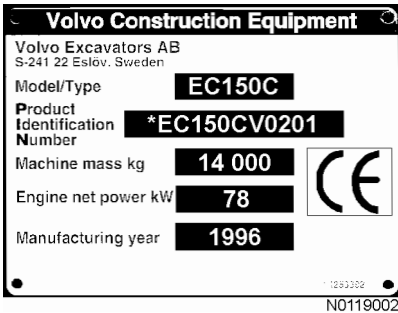

Figure 1

The **product nameplate** with model designation and number (PIN) is located on the outside of the cab under the left rear side window.

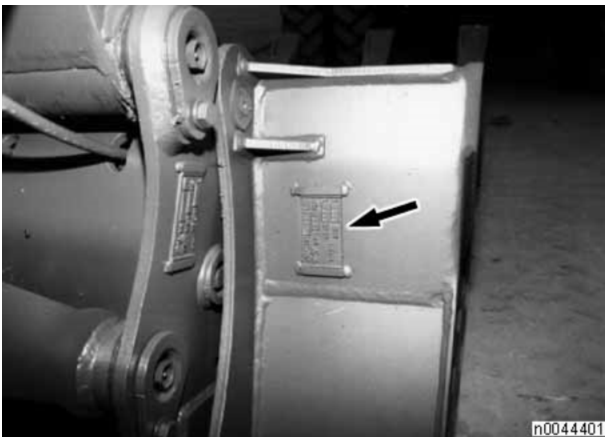

Figure 2

The **bucket's nameplate** with article and change number, weight and volume is on the top side of the bucket to the left of the bucket hinge.



**Figure 3**

The **diesel engine's type designation** and article number are located, on a nameplate, on the valve cover. Product and serial numbers are stamped on the left side of the engine in the top edge of the engine block.

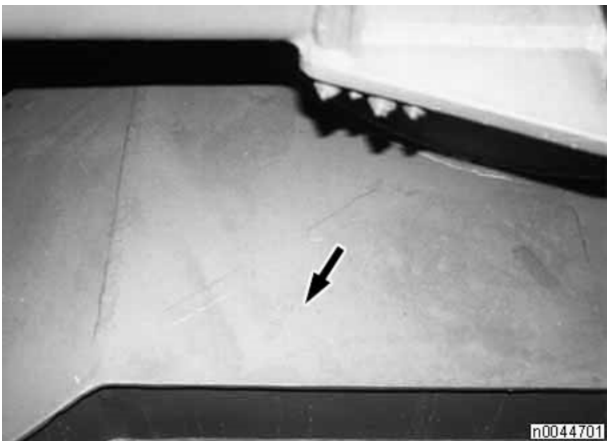

**Figure 4**

The **superstructure's article** and change numbers and the machine's serial number are stamped on the right boom bracket.



**Figure 5**

The **undercarriage's article** and change numbers are stamped in front and to the right of the slewing ring.

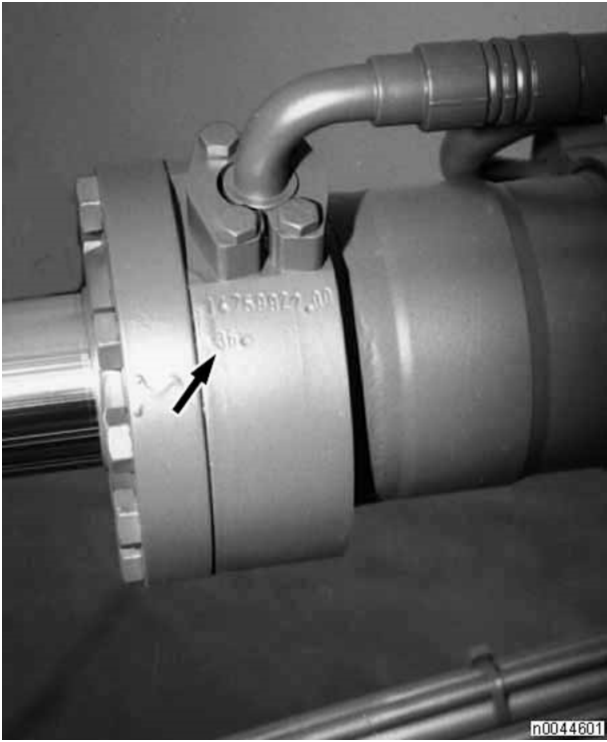

**Figure 6**

**The hydraulic cylinders' article** and change numbers are stamped on the cylinder barrel next to the oil connection on the piston rod side.

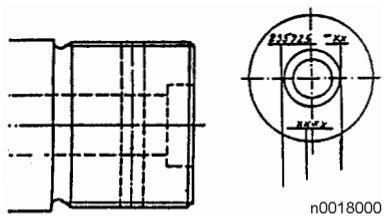

**Figure 7**

**The piston rods' article** and change numbers are stamped on the end surface of the piston rods.

Document Title: <b>General</b>	Function Group: <b>030</b>	Information Type: <b>Service Information</b>	Date: <b>7/8/2025</b>
Profile:			

## General

**The data apply only to machines equipped as per factory standard.  
For machines with other equipment – see appropriate specification.**

Max. tractive force, (gross)	147 kN (14.7 Mp)
Travel speed, CAP	5.4 km/h
Travel speed, ECO	2.6 km/h
Travel speed, HLD	-
Gradeability	49°

Document Title: <b>Main dimensions</b>	Function Group: <b>030</b>	Information Type: <b>Service Information</b>	Date: <b>7/8/2025</b>
Profile:			

### Main dimensions

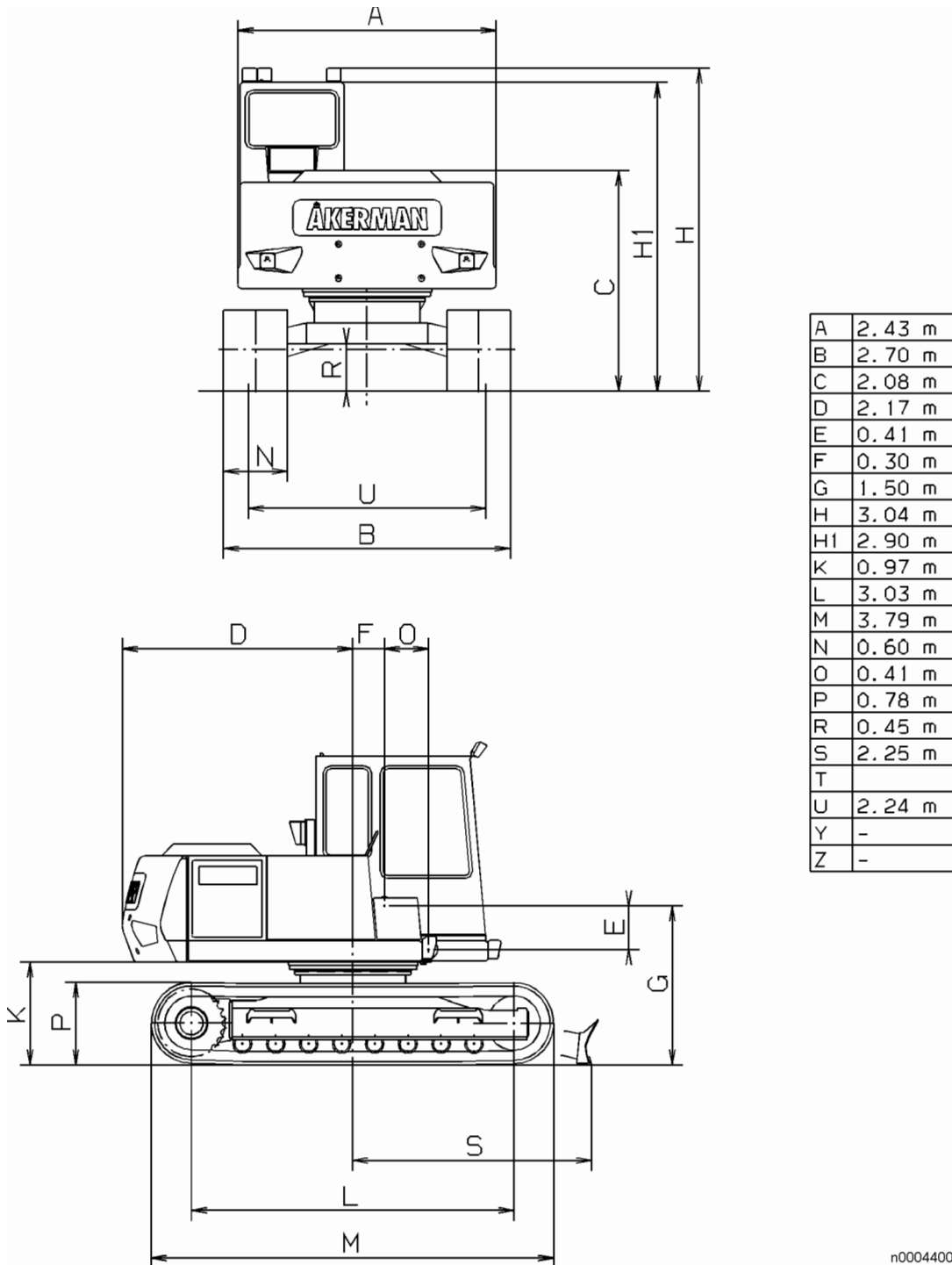

Figure 1

Document Title: <b>Tightening torque</b>	Function Group: <b>030</b>	Information Type: <b>Service Information</b>	Date: <b>7/8/2025</b>
Profile:			

## Tightening torque

Joints should be tightened to the prescribed torque without interruption so that the greater resting friction will not release the torque wrench unnecessarily.

The tables below are taken from Volvo Excavator's standard. For complete information, see EXC 42071, 120 and EXC 42071, 130.

### Before fitting pipe couplings, plugs and hoses:

- Make sure that the sealing surfaces are clean, free of pores and scratches and have the prescribed surface texture.
- Check elastic sealing rings for defects.
- Oil threads, tapers, sealing and contact surfaces.

### Drawing specifications:

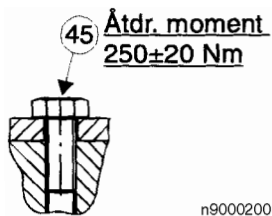
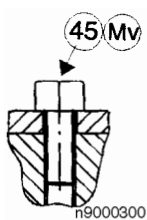

**Figure 1**

Observe torque specified in drawing.

The torque may be higher or lower than the "standard value".

The torque accuracy requirement is very strict.



**Figure 2**

Item no. with "Mv" for individual screw or coupling, entails torque as per EXC standard and strict torque accuracy requirement.



**Figure 3**

"MV-note" on drawing, scope as per supplementary text, entails torque as per EXC standard and that all screw joints must meet strict torque accuracy requirement

## Recommended tolerances for tightening torque

Tightening torque in Nm (lbf ft)	Tolerance
5–10 (6.8–13.6)	± 1.5
11–50 (15–37)	± 4
51–100 (37.5–73.5)	± 10
101–200 (74–147)	± 20
201–400 (148–295)	± 40
401–1000 (296–738)	± 80
1001 – (739–)	± 100

## Tapped threads – tightening torque

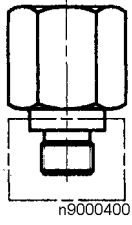
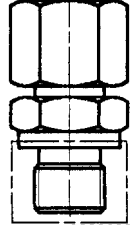
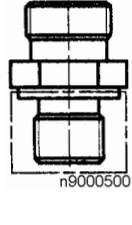
GE 	EGE 	RI 	Thread (inch/mm)	Pressure class	Pipe o.d. mm (in)	Width across flats mm (in)	Torque Nm (lbf ft)
14 012 413	14 023 056	*)	G 1/4	Low	8 (0.31)	19 (0.75)	40 (29.5)
14 012 418	14 023 611	*)	G 1/4	Low	10 (0.39)	19 (0.75)	40 (29.5)
14 012 423	14 012 381	*)	G 1/2	Low	15 (0.59)	27 (1.06)	100 (73.8)
14 012 431	-	*)	G 3/4	Low	22 (0.87)	32 (1.26)	200 (147.5)
14 015 486	-	-	G 1/4	High	8 (0.31)	19 (0.75)	60 (44.3)
14 012 428	14 211 062	*)	G 3/4	High	20 (0.79)	32 (1.26)	200 (147.5)
14 012 432	14 012 382	*)	G 1	High	25 (0.98)	41 (1.61)	350 (258)
14 012 433	14 042 775	*)	G 1 1/4	High	30 (1.18)	50 (1.97)	500 (369)
14 012 436	14 023 190	*)	G 1 1/2	High	38 (1.50)	55 (2.17)	600 (443)
14 025 136	-	-	M 12x1.5	Low	8 (0.31)	17 (0.67)	30 (22)
14 100 430	14 341 573	-	M 14x1.5	Low	10 (0.39)	19 (0.75)	50 (36.9)
14 213 266	14 340 537	-	M 16x1.5	Low	12 (0.47)	22 (0.87)	60 (44.3)
14 012 424	14 263 962	-	M 18x1.5	Low	15 (0.59)	24 (0.94)	80 (59)
14 012 430	-	-	M 26x1.5	Low	22 (0.87)	32 (1.26)	200 (147.5)
14 012 416	-	-	M 14x1.5	High	8 (0.31)	19 (0.75)	60 (44.3)
14 211 561	-	-	M 16x1.5	High	10 (0.39)	22 (0.87)	80 (59)
14 266 715	14 266 716	-	M 22x1.5	High	16 (0.63)	27 (1.06)	150 (111)
14 211 250	14 211 244	-	M 27x2.0	High	20 (0.79)	32 (1.26)	200 (147.5)
14 025 324	-	-	M 33x2.0	High	25 (0.98)	41 (1.61)	350 (258)
14 016 814	14 016 813	-	M 42x2.0	High	30 (1.18)	50 (1.97)	500 (369)
-	-	-	M 48x2.0	High	38 (1.50)	55 (2.17)	600 (443)

\*) Several different art. nos. and across-flats widths exist for each nominal pipe size.

## Flange halves – tightening torque

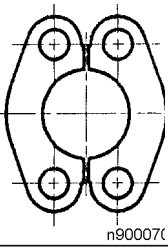
	SAE size	Pressure class (psi)[1]	Screw size zinc-coated, chromated	Width across flats mm (in)	Hex socket drive mm (in)	Torque Nm (lbf ft)
14 053 650	3/4	6000	M10x35	16 (0.63)	8 (0.31)	45 (33)
14 048 189	1	6000	M12x40	18 (0.71)	10 (0.39)	80 (59)
14 024 055	1 1/4	6000	M12x45	18 (0.71)	12 (0.47)	80 (59)
14 236 931	1 1/4	6000	M14x50	21 (0.83)	10 (0.39)	125 (92)
14 211 121	1 1/2	6000	M16x60	24 (0.94)	14 (0.55)	190 (140)

## Hose clips – tightening torque

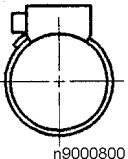
	For outside diameter mm (in)	Width across flats mm (in)	Torque Nm (lbf ft)	Torque "2" after warming-up Nm (lbf ft)
943 469	10–13 (0.39–5.12)	7 (0.28)	2.5–3.5 (1.8–2.6)	-
943 470	(13)–16 (5.12–6.30)	7 (0.28)	2.5–3.5 (1.8–2.6)	-
-	(16)–19 (6.30–0.75)	7 (0.28)	4–5 (3.0–3.7)	-
943 472	(19)–23 (0.75–0.91)	7 (0.28)	4–5 (3.0–3.7)	-
943 473	(23)–27 (0.91–1.06)	7 (0.28)	4–5 (3.0–3.7)	-
943 474	(27)–30 (1.06–1.18)	7 (0.28)	4–5 (3.0–3.7)	-
943 475	(30)–36 (1.18–1.42)	7 (0.28)	4–5 (3.0–3.7)	-
943 476	(36)–43 (1.42–1.70)	7 (0.28)	5–6 (3.7–4.4)	-
943 477	(43)–49 (1.70–1.93)	7 (0.28)	5–6 (3.7–4.4)	-
943 478	(49)–54 (1.93–2.13)	7 (0.28)	5–6 (3.7–4.4)	-
943 479	(54)–64 (2.13–2.52)	7 (0.28)	5–6 (3.7–4.4)	-
943 480	(64)–73 (2.52–2.87)	7 (0.28)	5–6 (3.7–4.4)	-
943 481	(73)–83 (2.87–3.27)	7 (0.28)	5–6 (3.7–4.4)	-
943 482	(83)–93 (3.27–3.66)	7 (0.28)	5–6 (3.7–4.4)	-
943 483	(93)–110 (3.66–4.33)	7 (0.28)	5–6 (3.7–4.4)	-
943 484	(110)–136	7 (0.28)	5–6	-

	(4.33–5.35)		(3.7–4.4)	
943 485	(136)–163 (5.35–6.42)	7 (0.28)	5–6 (3.7–4.4)	-
14 016 541	(163)–180 (6.42–7.10)	7 (0.28)	5–6 (3.7–4.4)	-
14 042 985	(205)–231 (8.10–9.10)	7 (0.28)	5–6 (3.7–4.4)	-
PA -RI				
14 261 827	(39)–45 (1.54–1.77)	5 (0.20)	5 (3.69)	5 (3.69)
14 261 828	(49)–55 (1.93–2.17)	5 (0.20)	5 (3.69)	5 (3.69)
14 261 829	(61)–67 (2.40 – 2.64)	5 (0.20)	5 (3.69)	5 (3.69)
14 261 830	(73)–79 (2.87–3.11)	5 (0.20)	5 (3.69)	5 (3.69)

### Banjo couplings – tightening torque

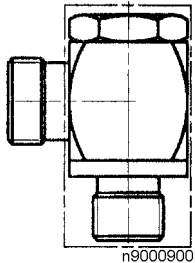
WH	Thread (inch/ mm)	Pressure class	Pipe o.d. mm (in)	Across-flats width mm (in)	Torque Nm (lbf ft)
					
14 026 430	G 1/4	Low	8 (0.31)	19 (0.75)	50 (36.9)
14 026 431	G 1/4	Low	10 (0.39)	19 (0.75)	50 (36.9)
14 026 152	G 1/2	Low	15 (0.59)	30 (1.18)	130 (95.9)
14 214 142	G 1/4	High	8 (0.31)	19 (0.75)	50 (36.9)
14 211 073	G 3/4	High	20 (0.79)	36 (1.42)	250 (184)
14 213 319	M 12x1.5	Low	8 (0.31)	19 (0.75)	50 (36.9)
14 213 320	M 14x1.5	Low	10 (0.39)	19 (0.75)	60 (44.3)
14 213 321	M 16x1.5	Low	12 (0.47)	24 (0.94)	90 (66.4)
14 026 454	M 18x1.5	Low	15 (0.59)	27 (1.07)	110 (81.1)
14 215 499	M 22x1.5	Low	18 (0.71)	30 (1.18)	150 (111)

### Pipe nuts – tightening torque

Thread (mm)	Pressure class	Pipe o.d. mm (in)	Across-flats width mm (in)	Torque Nm (in)
M12x1.5	Low	6 (0.24)	14 (0.55)	25 (18.4)
M14x1.5	Low	8 (0.31)	17 (0.67)	35 (25.8)
M16x1.5	Low	10 (0.39)	19 (0.75)	45 (33.2)
M18x1.5	Low	12 (0.47)	22 (0.87)	75 (55.3)
M22x1.5	Low	15 (0.59)	27 (1.07)	110 (81.1)
M26x1.5	Low	18 (0.71)	32 (1.26)	180 (133)
M30x2.0	Low	22 (0.87)	36 (1.42)	280 (207)
M36x2.0	Low	28 (1.10)	41 (1.61)	300 (221)
M45x2.0	Low	35 (1.38)	50 (1.97)	450 (332)

M52x2.0	Low	42 (1.65)	60 (2.36)	680 (502)
M14x1.5	High	6 (0.24)	17 (0.67)	45 (33.2)
M16x1.5	High	8 (0.31)	19 (0.75)	65 (47.9)
M18x1.5	High	10 (0.39)	22 (0.87)	80 (59.0)
M20x1.5	High	12 (0.47)	24 (0.94)	100 (73.8)
M22x1.5	High	14 (0.55)	27 (1.07)	140 (103)
M24x1.5	High	16 (0.63)	30 (1.18)	160 (118)
M30x2.0	High	20 (0.79)	36 (1.42)	350 (258)
M36x2.0	High	25 (0.98)	46 (1.81)	450 (332)
M42x2.0	High	30 (1.18)	50 (1.97)	650 (479)
M52x2.0	High	38 (1.50)	60 (2.36)	800 (590)

### Bolts/nuts – tightening torque

Across-flats width mm (in) Flange	Across-flats width mm (in) Hexagonal (mm/inch)	Across-flats width mm (in) Hex socket (mm/inch)	Thread	Torque Nm (lbf ft) qual.: 8.8 zinc-coated chromated dry	Torque Nm (lbf ft) qual.: 10.9 untreated oiled	Torque Nm (lbf ft) qual.: 10.9 zinc-coat oiled	Torque Nm (lbf ft) qual.: 12.9 untreated oiled
8 (0.31)			M5				
10 (0.39)	10 (0.39)	5 (0.20)	M6	10 (7.38)	15 (11.1)	13 (9.59)	20 (14.8)
12 (0.47)	13 (0.51)	6 (0.24)	M8	25 (18.4)	35 (25.8)	32 (23.6)	40 (29.5)
14 (0.55)	16 (0.63)	8 (0.31)	M10	45 (33.2)	65 (47.9)	62 (45.7)	80 (59.0)
17 (0.67)	18 (0.71)	10 (0.39)	M12	80 (59.0)	120 (88.5)	109 (80.4)	140 (103)
18 (0.71)	21 (0.83)	12 (0.47)	M14	125 (92.2)	180 (133)	174 (128)	220 (162)
21 (0.83)	24 (0.94)	14 (0.55)	M16	190 (140)	280 (207)	266 (196)	340 (251)
	30 (1.18)	17 (0.67)	M20	370 (273)	540 (398)	370 (273)	650 (479)
	36 (1.42)	19 (0.75)	M24	640 (472)	940 (693)	898 (662)	1120 (826)
	41 (1.61)	-	M27	830 (612)	1350 (996)	1296 (956)	1620 (1195)
	46 (1.81)	22 (0.87)	M30	1260 (929)	1840 (1357)	1765 (1302)	2210 (1630)
	55 (2.17)		M36	2190 (1615)	3210 (2368)	3082 (2273)	3850 (2840)
	7/16	3/16	1/4	10 (7.38)	15 (11.1)	14 (10.3)	20 (14.8)
	1/2	1/4	5/16	20 (14.8)	30 (22.1)	30 (22.1)	40 (29.5)
	9/16	5/16	3/8	35 (25.8)	55 (40.6)	52 (38.4)	70 (51.6)
	3/4	3/8	1/2	90 (66.4)	130 (95.9)	125 (92.2)	170 (125)
	15/16	1/2	5/8	180 (133)	260 (192)	249 (184)	330 (243)
	1 1/8	5/8	3/4	310 (229)	460 (339)	437 (322)	570 (420)
	1 5/16	-	7/8	500 (369)	730 (538)	700 (516)	910 (671)
	1 1/5	3/4	1	740 (546)	1090 (804)	1046 (772)	1360 (1003)

### Pipe plugs – tightening torque

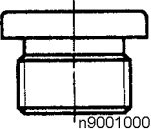
VS 	Thread (inch/mm)	Pressure class (bar) [2]	Hex socket drive mm (in)	Torque Nm (lbf ft)
14 023 406	G 1/8	400	5 (0.20)	15 (11.1)

14 023 407	G 1/4	400	6 (0.24)	33 (24.3)
14 023 408	G 3/8	400	8 (0.31)	70 (51.6)
14 023 409	G 1/2	400	10 (0.39)	90 (66.4)
14 023 410	G 3/4	400	12 (0.47)	150 (111)
14 023 411	G 1	400	17 (0.67)	250 (184)
14 215 723	G 1 1/4	400	22 (0.87)	600 (443)
14 215 724	G 1 1/2	400	24 (0.94)	800 (590)
14 023 412	G 1 1/4	250	22 (0.87)	500 (369)
14 023 413	G 1 1/2	250	24 (0.94)	500 (369)
14 024 363	M 10x1.0	400	5 (0.20)	13 (9.59)
14 211 624	M 12x1.5	400	6 (0.24)	30 (22.1)
14 211 623	M 14x1.5	400	6 (0.24)	40 (29.5)
14 211 625	M 16x1.5	400	8 (0.31)	60 (44.3)
14 024 814	M 18x1.5	400	8 (0.31)	70 (51.6)
14 024 233	M 22x1.5	400	10 (0.39)	100 (73.8)
14 340 607	M 26x1.5	400	12 (0.47)	120 (88.5)
14 266 484	M 27x2.0	400	12 (0.47)	150 (111)
14 267 223	M 33x2.0	400	17 (0.67)	250 (184)
14 212 167	M 42x2.0	250	22 (0.87)	400 (295)

### Pipe couplings and hose with DKO-connections (O-ring-sealed taper) – tightening torque

Tighten DKO connections with open-ended torque wrench.

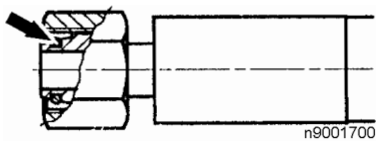

**Figure 4**  
O-ring

EW	ET	EL	EGE	RED		Thread (inch/ mm)	Pressure class[3]	Pipe o.d. mm (in)	Across- flats width mm (in)	Torque Nm (lbf ft)
14 012 391	14 012 387	14 012 383	*)	*)	*)	M14x1.5	L	8 (0.31)	17 (0.67)	30 (22.1)
14 012 393	14 012 388	14 052 740	*)	*)	*)	M16x1.5	L	10 (0.39)	19 (0.75)	45 (33.2)
14 012 395	14 012 389	14 012 384	*)	*)	*)	M22x1.5	L	15 (0.59)	27 (1.06)	75 (55.3)
14 012 397	14 043 552	14 043 547	–	*)	*)	M30x1.5	L	22 (0.87)	36 (1.42)	110 (81.1)

14 015 392	–	14 215 487	–	–	*)	M16x1.5	S	8 (0.31)	19 (0.75)	40 (29.5)
14 310 009	–	–	–	*)	–	M18x1.5	S	10 (0.39)	22 (0.87)	50 (36.9)
14 214 854	14 341 817	14 341 816	–	–	–	M24x1.5	S	16 (0.63)	30 (1.18)	80 (59.0)
14 012 396	14 211 064	14 211 065	*)	*)	*)	M30x2.0	S	20 (0.79)	36 (1.42)	120 (88.5)
14 012 398	14 024 423	14 012 385	*)	*)	–	M36x2.0	S	25 (0.98)	46 (1.81)	170 (125)
–	–	–	–	–	*)	M36x2.0	S	25 (0.98)	41 (1.61)	170 (125)
14 012 399	14 012 390	14 012 386	*)	*)	*)	M42x2.0	S	30 (1.18)	50 (1.97)	250 (184)
14 016 972	–	14 016 554	*)	*)	*)	M52x2.0	S	38 (1.50)	60 (2.36)	350 (258)

\*) Several different art. nos. exist for each nominal pipe size.

**[1]**6000 psi = 41.4 MPa.

**[2]**250 bar = 25 MPa = 3 625 psi, 400 bar = 40 MPa = 5 800 psi.

**[3]**L – Low, S – High

Document Title: <b>Weights</b>	Function Group: <b>030</b>	Information Type: <b>Service Information</b>	Date: <b>7/8/2025</b>
Profile:			

## Weights

Base machine with 600 mm track gauge (excl. digging equipment)	14 700 kg
Superstructure, excl. counterweight and diesel engine	approx. 6 645 kg

### Working weights and ground pressures for complete excavator with:

4.9 m boom, 2.4 m dipper arm, 325 kg (600/700 l) bucket and 2 500 kg counterweight, 88 kg quickfit device, full tank, operator.

Track gauge	Boom		Adjustable boom	
	Ground pressure	Operating weight	Ground pressure	Operating weight
600 mm	36.4 kPa (0.37 kgf/cm <sup>2</sup> )	14 700	37.4 kPa (0.37 kgf/cm <sup>2</sup> )	15 100
750 mm	29.8 kPa (0.286 kgf/cm <sup>2</sup> )	15 050	30.6 kPa (0.31 kgf/cm <sup>2</sup> )	15 450
900 mm	25.4 kPa (0.244 kgf/cm <sup>2</sup> )	15 400	26.1 kPa (0.26 kgf/cm <sup>2</sup> )	15 800

Document Title: <b>Transport data</b>	Function Group: <b>050</b>	Information Type: <b>Service Information</b>	Date: <b>7/8/2025</b>
Profile:			

## Transport data

### Transport data in metres

<b>Boom length</b>	<b>4.9</b>	
<b>Dipper arm length</b>	<b>2.0</b>	<b>2.4</b>
Min. transport length with folded-in equipment (A)	7.5	7.5
Max. transport height with folded-in equipment (B)	3.0	3.0
Centre of gravity in front of slewing centre with folded-in equipment (C)	-	-
Total length with extended equipment (D)	11.0	11.0
Min. transport height with extended equipment (E)	3.0	3.0
Centre of gravity in front of slewing centre with extended equipment (F)	-	-

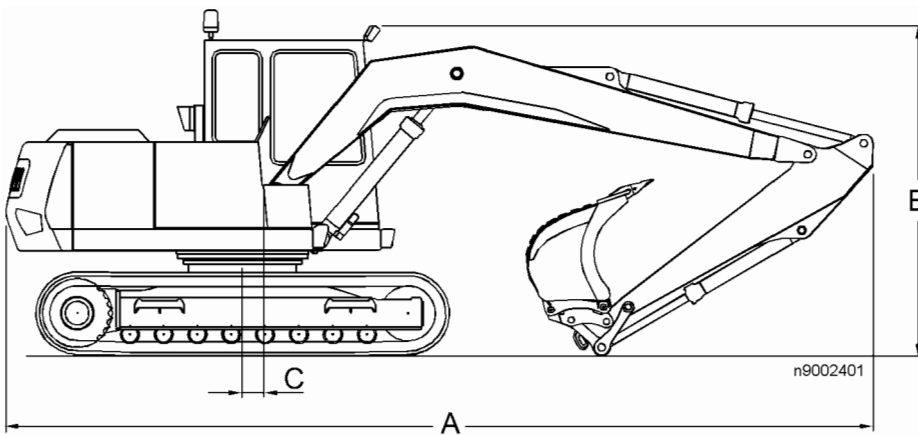

**Figure 1**

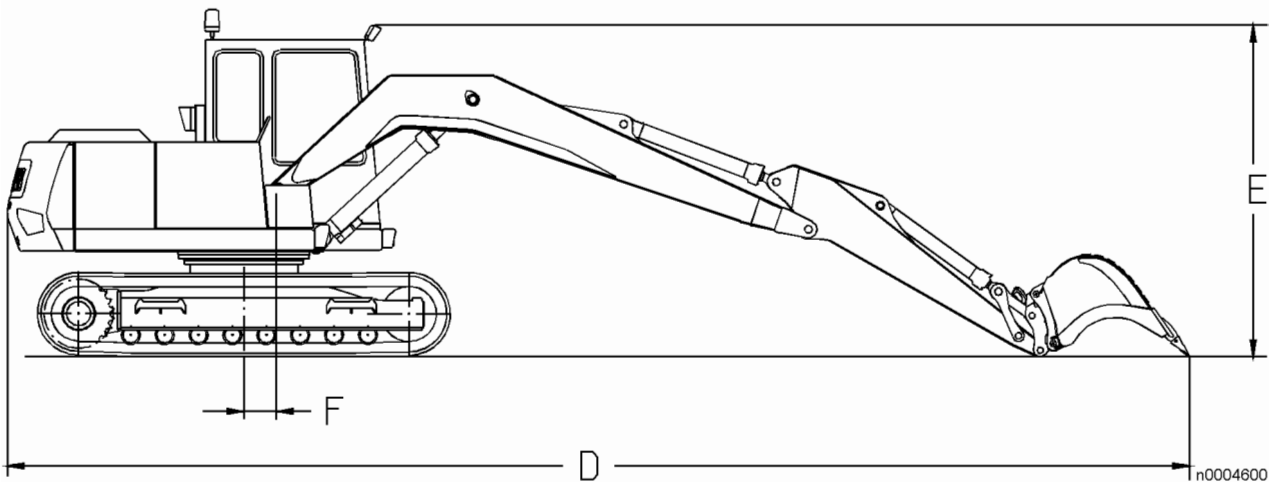

Figure 2

Document Title: <b>Hydraulic oil recommendations</b>	Function Group: <b>160</b>	Information Type: <b>Service Information</b>	Date: <b>7/8/2025</b>
Profile:			

## Hydraulic oil – recommendations

<b>Oil type</b>	<b>Viscosity</b>	<b>Ambient temperature</b>	<b>Miscibility</b>	<b>Remark</b>
SHS 32 Mineral oil	ISO VG 32 HR	-30 to +35 °C	Miscible with SHS 46	
SHS 46 Mineral oil	ISO VG 46 HR	-15 to +50 °C	Miscible with SHS 32	
PANOLIN HLP SE SYNTH 46 (Biodegradable) Synthetic oil	Same as for mineral oil	-15 to +50 °C		When changing from mineral oil to synthetic oil, contact Volvo Construction Equipment Service
BP BIOHYD SE 46 (Biodegradable) Synthetic oil	Same as for mineral oil	-15 to +50 °C		When changing from mineral oil to synthetic oil, contact Volvo Construction Equipment Service

The machine is normally delivered with oil type SHS 46.

Document Title: <b>Connection / disconnection of vacuum pump – instructions</b>	Function Group: <b>173</b>	Information Type: <b>Service Information</b>	Date: <b>7/8/2025</b>
Profile:			

## Connection / disconnection of vacuum pump – instructions

### Op nbr

[14 190 806 Vacuum pump](#)

[14 199 327 Adapter](#)

### Tools:

Spanners Widths across flats 36, 38



**Figure 1**

Vacuum pump and adapter



**Hydraulic oil under pressure and hot hydraulic oil can cause severe injuries.**

### Fitting



The air filter is located above the filtered hydraulic oil, so clean the surfaces around the air filter very carefully, as well as the inside and outside of the adapter. Do not leave the connection sleeve for the air filter open longer than it takes to screw the adapter and the air filter off and on.

1. Place the vacuum pump on the hydraulic tank.



The engine must not be running when the adapter blocks the venting of the hydraulic tank. This could cause pump failure.

2. Remove the air filter **1** and immediately screw on the adapter **2**.
3. Fit the vacuum pump's suction hose **3** onto the adapter's nipple **2**.

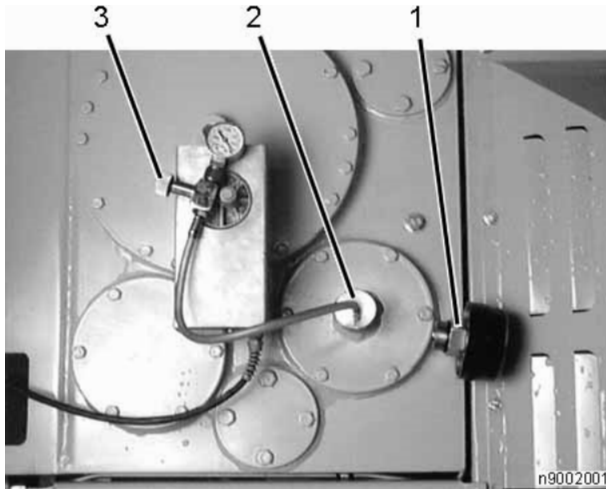

**Figure 2**  
Connection of vacuum pump

4. Connect the plug to the 24 V outlet in the cab on the left console next to the ignition lock.
5. Start the vacuum pump.
6. Set the vacuum pump to **-300 mbar** by means of the adjusting knob, see fig.

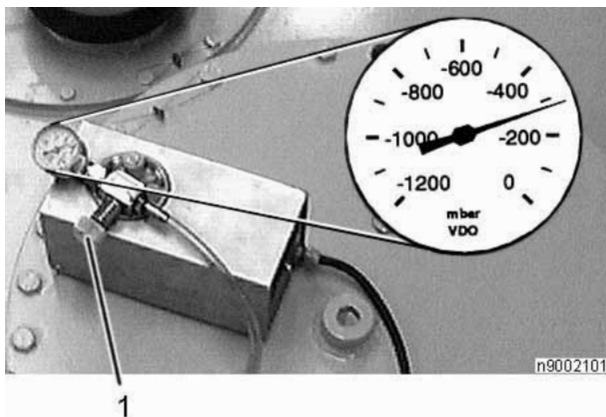

**Figure 3**

1. Adjusting knob

Let the vacuum pump work for 2–3 minutes so that the negative pressure stabilizes.  
Adjust the vacuum pump to **-300 mbar** when, for example, the return line to the hydraulic pump is freed.

## **CAUTION**

If the pressure is lower than -300 mbar, there is a risk that gearbox oil will be sucked into the hydraulic system and that the hydraulic oil tank will be damaged.

## **Removal**

7. Cut the power to the vacuum pump.
8. Remove the plug from the 24 V outlet.
9. Remove the vacuum hose from the adapter and the adapter from the connection sleeve.
10. Immediately screw the air filter onto the connection sleeve.

Document Title: <b>Dieseling in hydraulic cylinders</b>	Function Group: <b>173</b>	Information Type: <b>Service Information</b>	Date: <b>7/8/2025</b>
Profile:			

## **Dieseling in hydraulic cylinders**

If air gets into the hydraulic cylinders during repair work, it may become so hot when the pressure rises that the surrounding oil ignites due to an effect known as "dieseling". This causes burned piston seals and rings. The problem can be avoided by venting the lines to the hydraulic cylinders after repair work. This is done by operating the digging equipment (under no load) with full cylinder strokes until the air in the system is expelled.

The dipper arm and bucket cylinders should be oriented with the outlet end at the highest point, so that air will gather at that end, and the piston at the opposite end of the cylinder. Wait a minute or so after the cylinder reaches this position before running it towards the outlet end. Realign the cylinder so that its ends are reversed in height and run it to the opposite end position. Repeat this procedure several times (recommended: three to five times).

The boom cylinders, which cannot be aimed downward, must be run in and out about 5 times with no load in the bucket.

### **CAUTION**

If the cylinders are pressurized either because the machine is raised or a load is lifted in the bucket, without the cylinders having been vented first as described above, the seals will probably be damaged.

If a cylinder is to be pressure-tested after repairs, the piston rod should be run out and in a few times before the pressure is increased to the testing pressure.

Document Title: <b>Electrical system – rules for work in the system</b>	Function Group: <b>173</b>	Information Type: <b>Service Information</b>	Date: <b>7/8/2025</b>
Profile:			

## **Electrical system – rules for work in the system**

1. Always use fully charged and otherwise serviceable batteries for tests in the electrical system. If the batteries are not fully charged they must be charged or replaced with new ones.
2. Test the batteries with a hydrometer and a cell tester. The battery disconnecter must be turned off.
3. When installing a new battery: always be careful to connect the battery with the right polarity.
4. When batteries are replaced they must have the same capacity and voltage, e.g. 2 batteries 60 Ah and 12 V. The batteries should be of the same age, since the charging current needed for a battery to achieve a given voltage changes with the age of the battery.
5. Be sure to observe the instructions in the section *SAFETY* if a booster battery is needed for starting. [Invalid linktarget]
6. Before performing any tests of the alternator or regulator, the batteries and electrical leads must be checked regarding insulation, loose connections and corrosion. Check the alternator belt. Any defects must be rectified before the electrical tests are begun.
7. "Secure" connections must be used in all testing of the alternator. If a cable comes loose, both the alternator and the regulator may be ruined.
8. Connecting the alternator's current terminal to the chassis will damage the alternator, and may also damage the regulator.
9. Never disconnect the alternator's main lead or field lead with the engine running, since both the alternator and the regulator may be damaged.
10. When removing or fitting components in the electrical system, the battery's negative terminal must be disconnected first.
11. Never disconnect leads to an electronic unit when the unit is energized, since this could damage the circuitry.

Document Title: <b>Recommendations for cleanliness during hydraulic work</b>	Function Group: <b>173</b>	Information Type: <b>Service Information</b>	Date: <b>7/8/2025</b>
Profile:			

## Recommendations for cleanliness during hydraulic work



**Hydraulic oil under pressure and hot hydraulic oil can cause severe injuries.**

It is very important to keep the hydraulic system free of impurities, which can cause abnormal wear and can lead to breakdowns, which in turn means increased costs for service and repairs. Despite the filters incorporated in the system, extreme cleanliness should be observed in all handling of hydraulic components, oils and fluids.

### NOTE!

A vacuum pump should be used during work in the hydraulic system.

The recommendations are grouped as follows:

1. Repairs of hydraulic components carried out at a workshop.[Invalid linktarget]
2. Work in the hydraulic system carried out at a workshop.[Invalid linktarget]
3. Work in the hydraulic system carried out in the field.[Invalid linktarget]
4. Storage and transport of hydraulic components.[Invalid linktarget]
5. Storage and handling of hydraulic oil.[Invalid linktarget]

### 1. Repairs of hydraulic components at a workshop

- Work on hydraulic components should be carried out separately from other workshop activities in a "clean room". The room should have good ventilation and the floor must be coated with a dust-binding material. Machining, grinding etc. may not be carried out in the "clean room".
- The workplace should be equipped with thoroughly cleaned tools and suitable vessels for cleaning of hydraulic components.
- Vessels for cleaning of hydraulic components may not be used for other cleaning. The vessels should be cleaned frequently and filled with fresh cleaning solution. The vessels should have a removable grating at the bottom which separates the component from any bottom sludge.
- Components handled in the "clean room" should always be pre-washed first. Caustic soda solutions and the like, which cause corrosion, may not be used for cleaning.
- Work in the hydraulic system should always be planned so that it can be completed without prolonged interruption.
- Dry and clean compressed air, not cotton waste or rags, should be used to dry components cleaned during repairs.
- A repaired component should always be plugged with a clean plastic plug of a suitable size and then wrapped.
- Methods that do not stir up dust and dirt should be used for cleaning of the "clean room".
- Hands and work clothes should always be kept clean.

### 2. Work in the hydraulic system at a workshop

- The machine should be cleaned before being taken into the workshop.
- The workplace should be thoroughly tidied and the tools thoroughly cleaned and deburred.
- The machine should be screened off from other machines or workplaces where welding or grinding is carried out. Each repair site in the system should be cleaned and protected with plastic sheeting.
- The removed components and all open connections should be plugged immediately. The components should be placed in suitable containers wrapped in plastic sheeting. Welding may not be performed on the machine when connections are opened due to the fire hazard.
- The hydraulic components removed for repair should be cleaned before being taken into the "clean room".
- Drained oil should be poured into a vessel intended for waste oil and should not normally be re-used.
- If the tank is to be emptied and the oil has been found to be free of discolouration and impurities, the oil should be

transferred to a clean vessel, which is then sealed. This oil or new oil should be poured back via the filler plug on the lid of the hydraulic oil filter so the oil passes through the filter.

- When a component is refitted, the connection seat should be carefully checked and cleaned.
- Hands and work clothes should always be kept clean.

### **3. Work in the hydraulic system in the field**

- If necessary and possible, the machine should be moved to as dust-free an environment as possible. Alternatively, the machine should be screened off with plastic sheeting or the like.
- Thorough troubleshooting should be performed to prevent unnecessary repairs. Check movements, pressures, engine speed and listen. Adjustable spanners and pipe wrenches should not be used. When the source of the fault has been located, the repair site should be cleaned and plastic sheeting applied to protect against dirt.
- Replacement components should be used to avoid repairs in the field.
- The removed components and all open connections should be plugged immediately. Replaced components should be wrapped in plastic sheeting and placed in suitable containers. Components to be refitted should be stored plugged and wrapped in plastic sheeting in plastic containers.
- Drained oil should be poured into a vessel intended for waste oil and should normally not be re-used.
- If the tank is to be emptied, and the oil is found to be re-usable, it should be drained into a clean vessel which is then sealed. This oil or new oil should be poured back via the filler plug on the lid of the hydraulic oil filter so the oil passes through the filter.
- A suitable cleaning solution should be used for cleaning and poured up in a thoroughly cleaned vessel.
- Work clothes and hands should always be kept clean. If it is necessary to climb up on the machine, shoes should be cleaned thoroughly.
- After each job the tools should be thoroughly cleaned and deburred.

### **4. Storage and transport of hydraulic components**

- All hydraulic components should be kept in plastic bags or sheeting and be plugged. The wrapping may not be opened before the component is to be used.
- The service vans should be fitted out and equipped in a way that promotes order and cleanliness.
- Items too large to fit in the plastic containers should not be transported in the service vans. A trailer should be used for them.
- Each service van should carry a roll of plastic sheeting, plastic plugs of the most common sizes and plastic containers for components. Disposable plugs and plastic sheeting should be used.

### **5. Storage and handling of hydraulic oil**

- Hydraulic oil should be stored in well-sealed tanks or drums. Oil may not be drained next to locations where machining or welding is carried out.
- Oil should be added via the filler plug on the lid of the hydraulic oil filter so the oil passes through the filter.
- Prior to filling, the new oil should always be checked for contamination with water or other impurities by being examined in a glass.
- Containers used for transporting hydraulic oil should not be used for any other purpose. They should be labelled and cleaned frequently.
- At the slightest suspicion of contamination, oil samples should be taken and sent for analysis. If an analysis result is unsatisfactory or if major work has been done in the hydraulic system, the hydraulic oil should be cleaned immediately.
- The tank only needs to be cleaned if dirt has been deposited by the oil. Otherwise flushing-out is sufficient. Make sure the suction line is closed before cleaning is done with a suitable agent.

Document Title: <b>Shrinking – Instructions</b>	Function Group: <b>173</b>	Information Type: <b>Service Information</b>	Date: <b>7/8/2025</b>
Profile:			

## Shrinking – Instructions

1. General[Invalid linktarget]
2. Equipment[Invalid linktarget]
3. Heating[Invalid linktarget]
4. Assembling[Invalid linktarget]
5. Dismantling[Invalid linktarget]

### 1. General

By "shrinkage fit" is meant that, at a certain temperature difference and a consequent change in measurements, a shaft and a hub can be assembled and become fixed when the temperature of the heated part drops and its size shrinks.

Usually the shaft is kept at room temperature, or preferably below, whereas the hub is heated in different ways. This method used, for instance, when fitting a gear wheel to a shaft, is described below.

### 2. Equipment

- a. Heating equipment  
A gas burner with an adequate nozzle or an electric hot plate with an output of approx. 1500 – 2000 W, and a diameter of approx. 250 mm (10 in).
- b. Measuring equipment  
A shrinkage gauge Part. no. 14194288 for checking the correct measurement change in the hub.

### 3. Heating

Prior to heating, make sure that the hub and shaft are free from burrs and defects that might otherwise impede the assembling of the parts.

- a. Hot plate:  
Heat the gear wheel on the plate until the shrinkage gauge can be easily pushed into the hub. Avoid exposing the measuring pin to heat or cold, as this will change its measurement. We recommend cooling the gauge to room temperature in between the times the gauge is used.
- b. Gas flame:  
Concentrate the heating to a circular area around the hub corresponding to about half of the gear wheel diameter, see Fig. If the heat around the hub is to result in an increase in the diameter of the hole, some heat has to be added to the outer edge of the gear wheel. This has to be done with care so as not to damage the hardening of the gear teeth. Proceed with the heating of the gear wheel until the shrinkage gauge can be easily inserted in the hub.

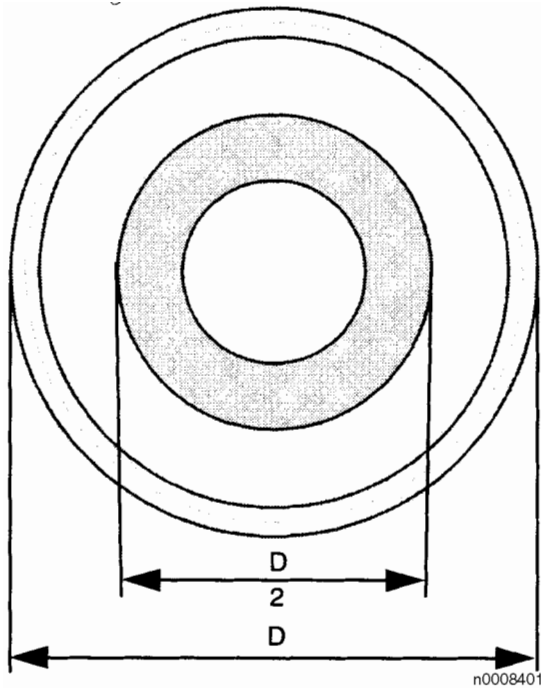

**Figure 1**

#### **4. Assembling**

Once the assembling has been started, the parts should be assembled as quickly as possible, to avoid heat from being transferred to the shaft, thus making assembling difficult or causing the parts to jam before they are correctly assembled. It is also important that the shaft is securely fixed in a vertical position in case the gear wheel should jam in an oblique position. With the shaft securely fixed it is easier to wriggle off the gear wheel quickly. If the gear wheel becomes fixed to the shaft before it is in its correct position, try to separate the wheel from the shaft as quickly as possible. If this is not possible, allow the parts to cool and proceed as described in the paragraph "Dismantling".

#### **5. Dismantling**

Try to press the shaft out of the hub without heating the hub. If this fails, apply pressure to the shaft in a hydraulic press. Gradually heat the hub, while the parts are fitted in the press, until the shaft loosens. If the heat is transmitted into the shaft, the shaft diameter increases with the risk that the fit will become too tight, thus making dismantling impossible. If the parts tend to bind because of the heat being transmitted into the shaft, stop the operation and cool off the parts. Then make a new dismantling attempt.

Document Title: <b>Welding on the machine – instructions</b>	Function Group: <b>173</b>	Information Type: <b>Service Information</b>	Date: <b>7/8/2025</b>
Profile:			

## **Welding on the machine – instructions**

### **WARNING**

**During electric welding on the machine or on an attachment coupled to the machine, components such as pivot points and electrical units may be damaged if the earth lead is incorrectly connected.**

To eliminate these risks, the following precautions should be taken before the start of electric welding:

- Cut off the power with the battery disconnecter.
- Connect the welding unit's earth connection as close to the weld as possible so that the current doesn't pass over a pivot point.

Document Title: <b>Jump-starting with a booster cable</b>	Function Group: <b>176</b>	Information Type: <b>Service Information</b>	Date: <b>7/8/2025</b>
Profile:			

## Jump-starting with a booster cable

Op nbr

Tools:

Booster batteries 2 12 V

Cables 3



### WARNING

**A discharged battery can explode due to a current surge if it is connected directly to a fully charged battery. This may cause injuries.**

To reduce the risk of current surge, the electrical resistance in the jump-start circuit should be increased. This can be done by always connecting the negative terminal on the booster package to a suitable earth connection on the chassis of the machine, see figure.

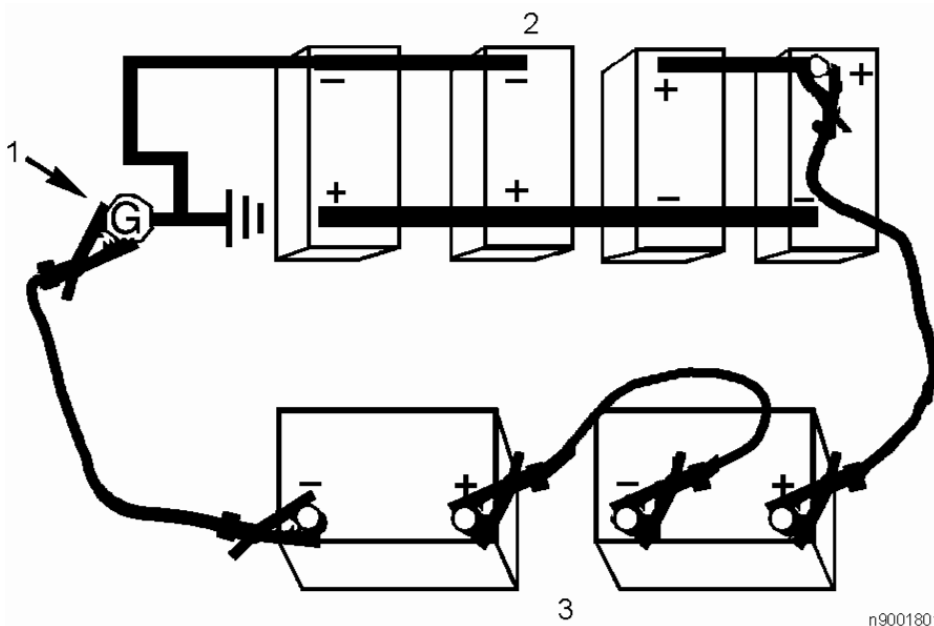

Figure 1

1. Chassi
2. Discharged batteries
3. Booster package

**Under no circumstances may the negative terminal on the booster package be connected directly to the negative terminal on the discharged batteries.**

### Connection of cables

1. Remove the cover and the terminal caps on the batteries.
2. Connect a cable between the two booster batteries as shown in the figure.
3. Connect a cable between the free positive terminal on the booster package and the positive terminal where the positive cable is connected to the discharged batteries.
4. Connect a cable between the free negative terminal on the booster package and a suitable chassis connection **G** on the superstructure of the machine.
5. Start the engine.

### **Removal of cables**

6. Remove the cable from the chassis connection **G**.
7. Remove the cable from the negative terminal on the booster package.
8. Remove the cable from the positive terminal on the discharged batteries.
9. Remove the cable from the positive terminal on the booster package.
10. Refit the terminal caps and the cover over the batteries.

Document Title: <b>Charging of batteries</b>	Function Group: <b>191</b>	Information Type: <b>Service Information</b>	Date: <b>7/8/2025</b>
Profile:			

## Charging of batteries

### **! WARNING**

Charging of batteries generates hydrogen gas, which is flammable and may be explosive. A short circuit, open flame or spark near the battery may cause a violent explosion.

Always interrupt the charging current before disconnecting the charging clips. Ensure good ventilation.

### **! WARNING**

The battery's electrolyte contains corrosive sulphuric acid. Any electrolyte spilled on the skin should be removed immediately. Wash with soap and plenty of water. If electrolyte gets into the eyes or any other sensitive part of the body – rinse immediately with plenty of water and seek prompt medical attention.



Figure 1

### Jump-starting with booster batteries

### **! WARNING**

The batteries may explode due to a current surge if a fully charged battery is connected directly to a discharged battery. This may cause injuries.

To reduce the risk of current surge, the resistance in the jump-start circuit should be increased. This is done by always connecting the negative terminal on the booster battery to a suitable earth connection on the machine. Under no circumstances may the negative terminal on the booster battery be connected directly to the negative terminal on the discharged battery.

The instruction *Jump-starting with a booster cable*[\[Invalid linktarget\]](#) must always be followed when starting the machine with booster batteries.

Document Title: <b>Fire protection</b>	Function Group: <b>191</b>	Information Type: <b>Service Information</b>	Date: <b>7/8/2025</b>
Profile:			

## Fire protection

At the least sign of fire, the following steps should be taken, if circumstances permit:

- Drive the machine away from the danger area.
- Lower the digging equipment to the ground.
- Shut off the engine with the engine shutoff control and turn the ignition key to the 0 position.
- Turn off the battery disconnecter.
- Start extinguishing the fire and notify the fire brigade if necessary.

### **WARNING**

**Special equipment is required for work in a flammable or explosive environment. Ask your dealer or your insurance company what is required.**

**When fire protection equipment is installed on the machine, it must be kept in working order. The equipment should be regarded as a complement to the operator's own efforts.**

- The risk of fire is always present. Find out what type of fire extinguisher you should use and learn to use it.

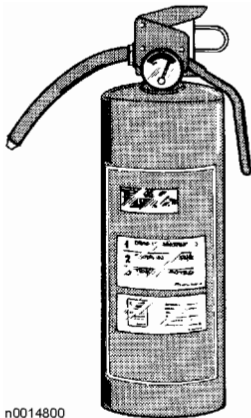

n0014800

**Figure 1**

- The fire extinguisher should be kept at the designated location in the cab or on the outside.
- Smoking and open flames are not permitted near the machine during fuelling or when the fuel system is open.