

TAKEUCHI

HYDRAULIC BREAKER

Instruction Manual
Parts List

TKB-101 TKB-101S

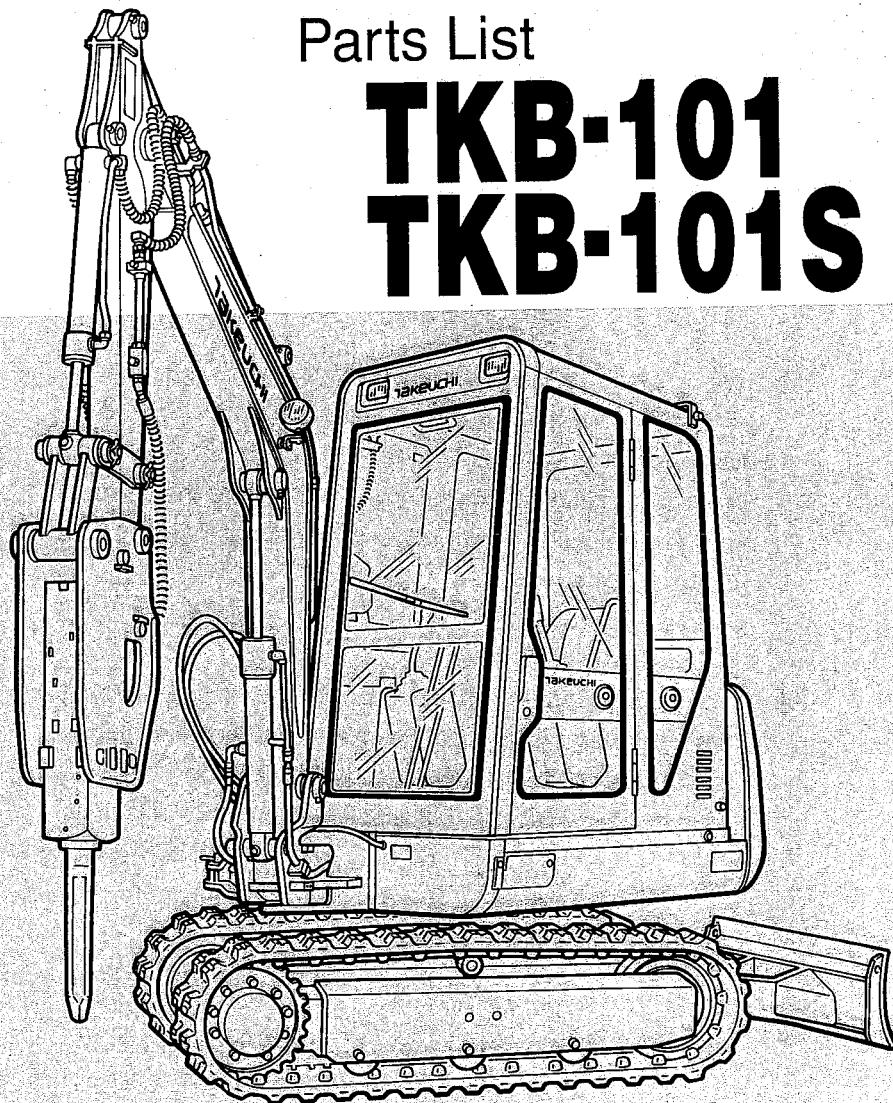

TAKEUCHI MFG.CO.,LTD.

WARNING

Improper use of the breaker may cause serious injury or death. Operators and maintenance personnel must read this manual before operating or maintaining the breaker. This manual should be kept in the Cab of the excavator for reference and periodically reviewed by all personnel concerned.

NOTICE

Takeuchi has operation and maintenance manuals written in several languages. If a manual in another language is required, contact your Takeuchi distributor.

Thank you for purchasing a Takeuchi Hydraulic Breaker.

Please be sure to read this Operation Manual through before use.

■ This manual contains important information regarding the safe and correct use of the Takeuchi Hydraulic Breaker. Please familiarise yourself with the instructions to avoid accidents resulting in serious injury or death to the operator or other employees and to avoid damage/break down to the breaker or excavator.

■ The manufacturer disclaims all liabilities arising through accidental loss or damage incurred or inadequate maintenance carried out. In the event of this manual being mislaid or lost, contact your local Takeuchi distributor for a replacement.

※ If you have any inquiry about the contents of this manual, contact with the distributor in your area.

PRIMARY SAFETY MATTERS TO BE OBSERVED

Serious injury or death may occur if safety rules for breaker operation, maintenance and repair procedures are not understood. To prevent accidents, be sure to read this manual carefully and understand it fully before operating the breaker for the first time or carrying out maintenance/repairs.



Please observe these signs throughout the manual. Failure to do so may result in serious injury or death to the operator or other employees.

■ SAFETY CLOTHES

When operating the breaker or carrying out any maintenance or repair work, always wear protective items appropriate for the job in hand. Some of the items shown below are mandatory on ALL Sites.

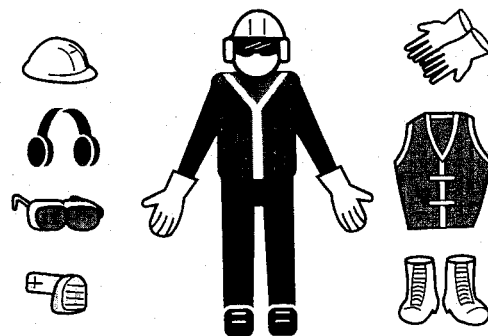

! DANGER

■ PAY ATTENTION TO AN OBSTACLE

Extreme caution must be taken when working near electric power lines.
Keep the minimum safe distance from the electric lines.
Ask the electric power company in advance for the voltage of power lines at the site.

MINIMUM SAFE DISTANCE FROM POWER LINES

TRANSMISSION VOLTAGE (V)	MINIMUM SAFE DISTANCE (m)
Service Wire	
6,600	3
Transmission Line	
33,000	4
66,000	5
154,000	8
275,000	10

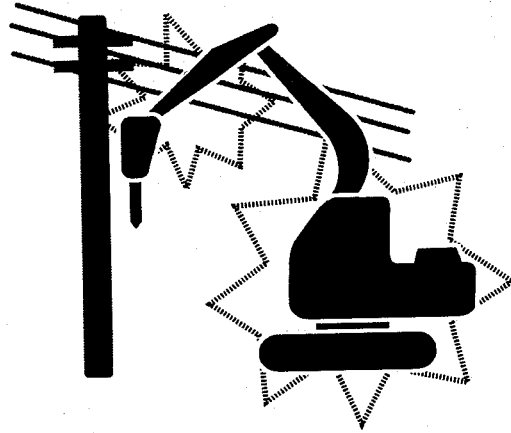

! WARNING

■ PAY ATTENTION WHEN REMOVING HYDRAULIC PARTS

The oil in the hydraulic tank is under high temperature and high pressure during operation, so care must be taken when removing caps, hoses, etc.
Always release the pressure in the tank before removing any parts.

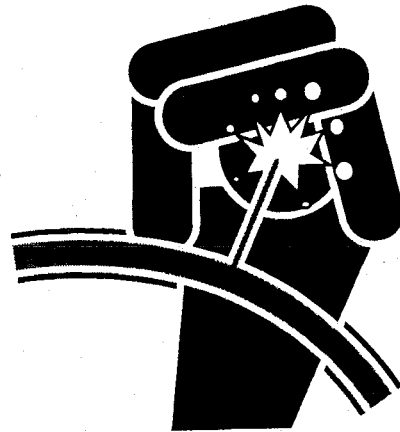

■ PAY ATTENTION TO FALLING OR SCATTERING OBJECTS

To provide protection from falling objects, flying rock splinters, etc., always secure safety guards to the cab of the excavator and wear the appropriate safety items.

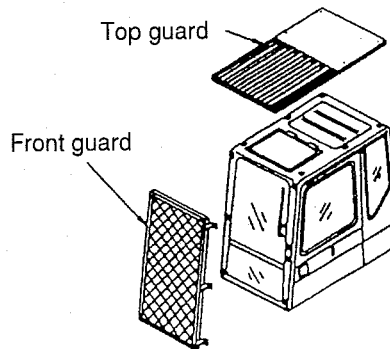
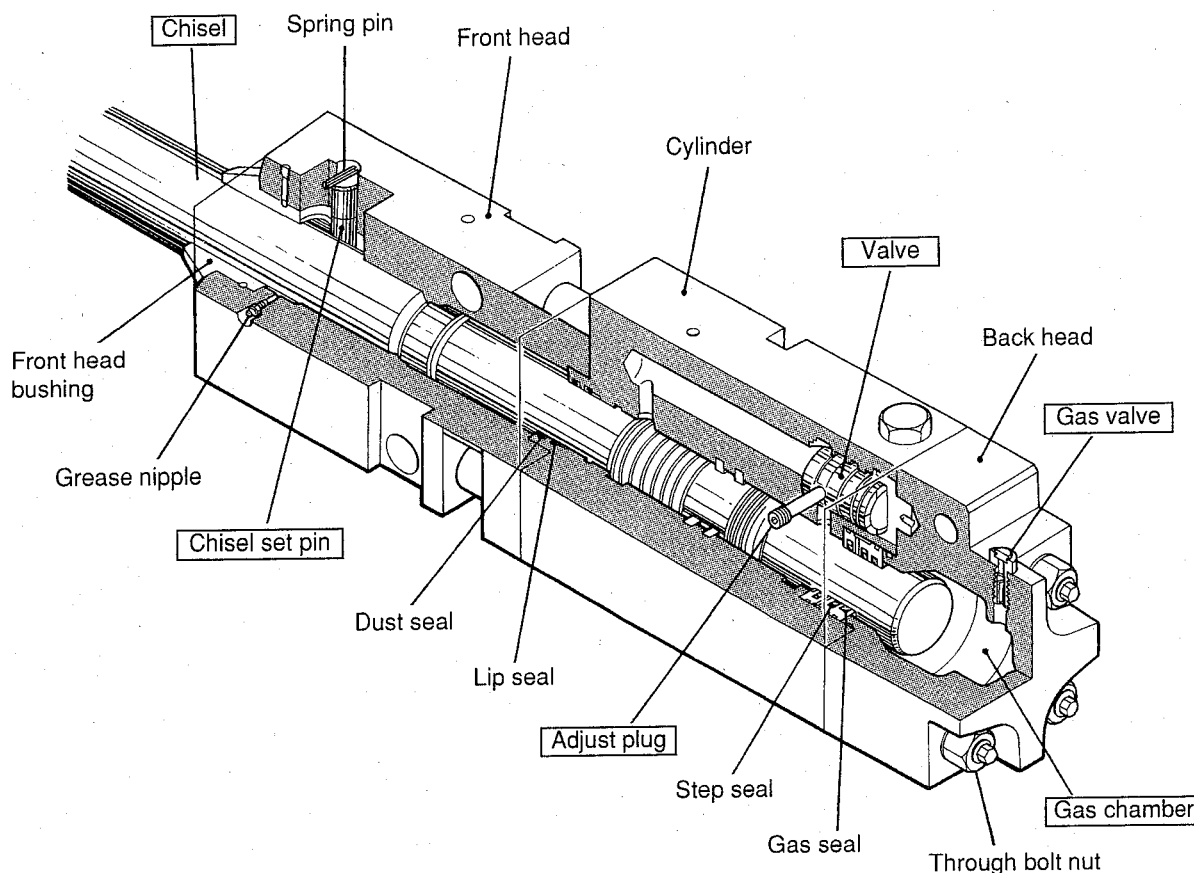

Table of Contents

		Page
Name and Function of Each Part	• Structural figure • Hydraulic piping	2
Do's and Don'ts		4
How to Operate the Breaker	• Pedal method • Valve switching method • Operation of the breaker	7
Removing & Attaching the Breaker	• Procedure to remove the breaker • Procedure to attach the breaker • Storage and maintenance of the breaker	8
How to Change Chisel	• Procedure to remove chisel • Procedure to fix chisel	10
Enclosure of Nitrogen Gas	• Inspection of gas pressure • N/A • When gas pressure is high • When gas pressure is low	11
How to Adjust Operating Pressure by Adjust Plug	• Procedure to adjust operating pressure	13
Maintenance	• Inspection items • Bolts • Gas pressure in the back head gas chamber • Checking for chisel set pin breakage • Chisel and chisel set pin • Chisel and front bushing • Greasing • Hydraulic • Oil leakage	14
Troubleshooting		18
Hydraulic Breaker		20
Breaker Parts List, Tool List		21
Hydraulic Breaker & Top Mount Type Bracket Group (TB025) (TB025 Long Arm) (TB030) (TB035) Parts List		22
Hydraulic Breaker & Flange Type Bracket Group Parts List		23
Hydraulic Breaker-S Type		24
Breaker-S Type Parts List, Tool List		25
Hydraulic Breaker & Flange-S Type Bracket Group Parts List		26
Chisel, Seal Kit Ass'y Parts List (Option)		27
Service Tool Gas Charger Ass'y (Nitrogen Gas Charging Tool) (Option)		28
Specifications		29

Name and Function of Each Part

■ Structural figure



Gas chamber

- Chamber enclosing N₂ (nitrogen gas)
- Gas energy to provide blowing power
 - Absorbs surge pressure from piston reaction
 - Break action for stable hydraulic pressure

Adjust plug

(Oil qty. adjustment structure)

By restricting the oil discharged at the time of piston retreat, to adjust the blowing power and number of blows.

Valve

Switches hydraulic circuit in the piston rear chamber

Chisel

Point type and flat end type chisels are available.
Select either one according to the application.

Gas valve

Injection port for nitrogen gas
Required pressure:
At low temp. 0.78~1.03 MPa
At high temp. 0.93~1.13 MPa

Chisel set pin

Retains chisel in bush housing.

Name and Function of Each Part

Hydraulic piping

Before fitting the breaker, ensure the excavator is piped with a breaker circuit. This is a separate circuit to operate the breaker only. If the excavator does not have a breaker circuit or if you are unsure, please contact your local Takeuchi distributor.

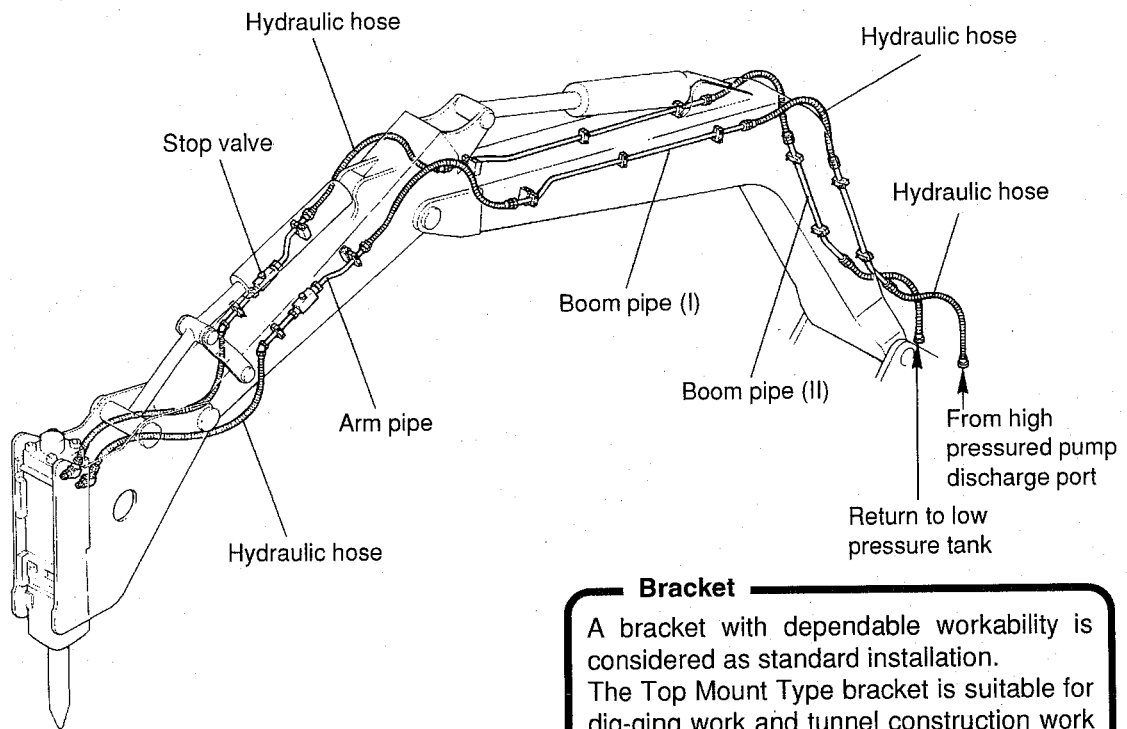

Bracket

A bracket with dependable workability is considered as standard installation. The Top Mount Type bracket is suitable for dig-ging work and tunnel construction work etc.

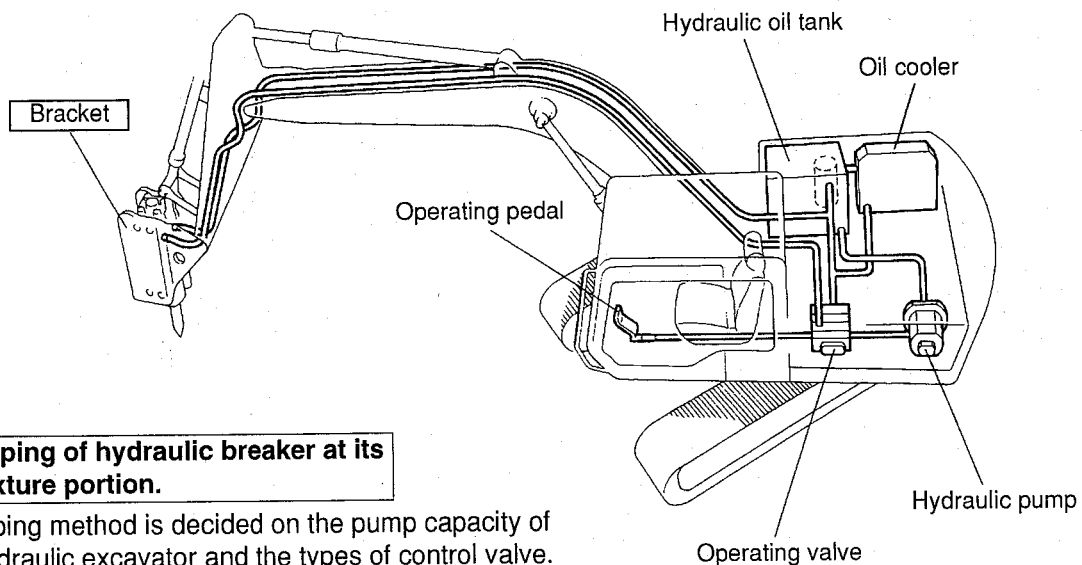

Piping of hydraulic breaker at its fixture portion.

Piping method is decided on the pump capacity of hydraulic excavator and the types of control valve.

- Direct connection system from the pump.
- Sub valve method.
- Switching from drive method.

Do's and Don'ts

Safety check before operation

Did you check it?

BOLTS AND NUTS

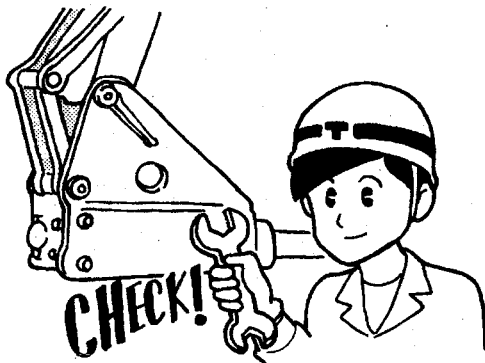

Please check that all bolts are tightened to the correct torque setting.
(For the tightening torque, see page 14 for 'bolts for each parts')

HYDRAULIC OIL LEVEL

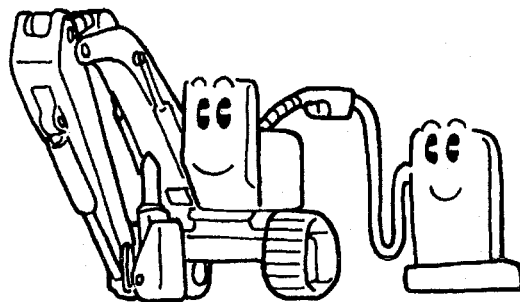

Please check oil level in hydraulic tank and top up if necessary.

GREASING UP

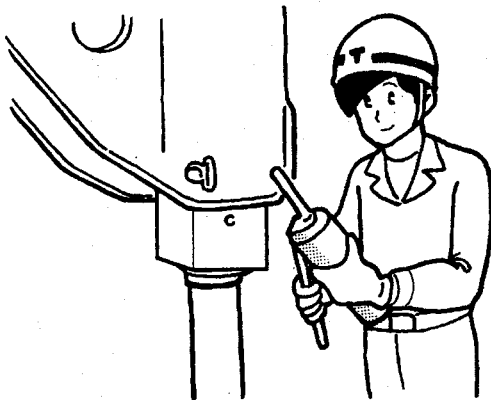

Apply grease to front head section of Breaker.
(For further details, see page 15 for 'greasing')

WARMING-UP (IDLING) OPERATION

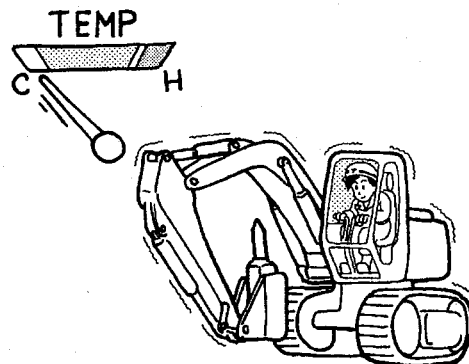

Allow excavator to idle for a few minutes and check temperature gauge is functioning before operating the breaker.

Do's and Don'ts

Safety check during operation

NEVER DO THIS, PLEASE!

Idling blows not permitted!

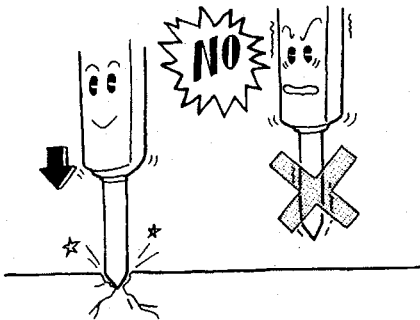

'Idling blow' means operating the breaker without the chisel contacting the material or the contact pressure is too light. This will cause wear, breakage or loosening of bolts and nuts.

Do not blow continuously

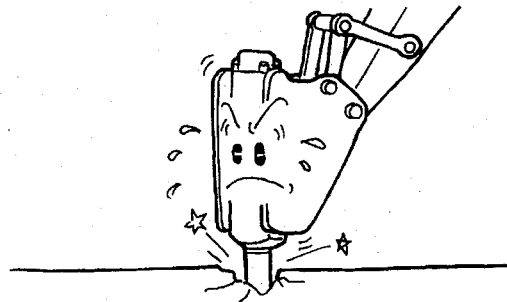

Please refrain from continuous blowing in the same point. This will cause premature wear to the chisel and other parts. If the material does not break after approx. one minute please advance to a different point.

Do not move the breaker back and forth once the material has been penetrated

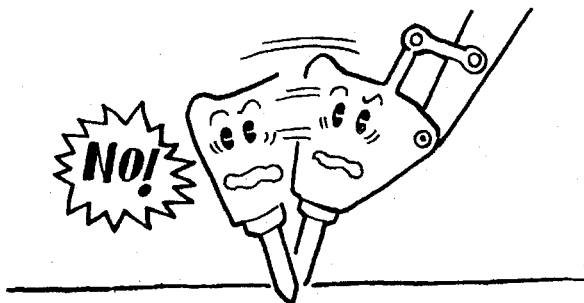

This will cause wear to through bolts, chisel and front bushing, and breakage may occur.

Do not strike the material violently

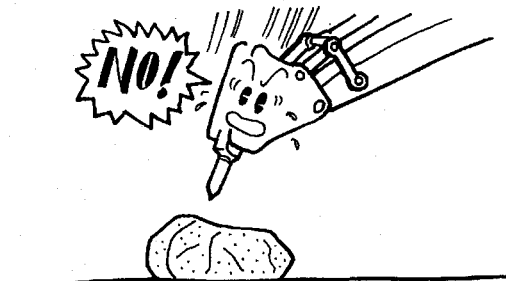

The hydraulic breaker is much heavier than the bucket. Please operate the excavator slowly and do not strike the material violently. This will cause damage to the excavator and breaker.

Do's and Don'ts

Safety check during operation

NEVER DO THIS, PLEASE!!

Please do not blow the object with cylinder stroke-end.

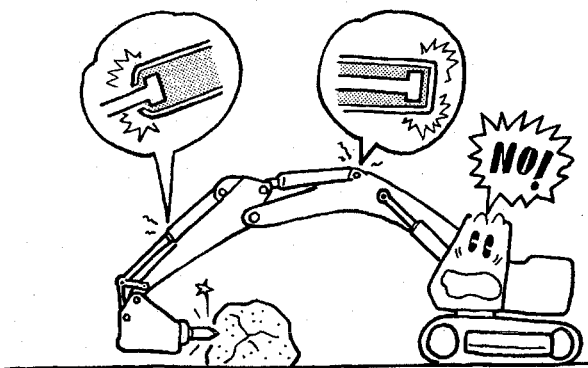

Operating the breaker with the cylinder and front section of excavator.

Do not operate the breaker under water.

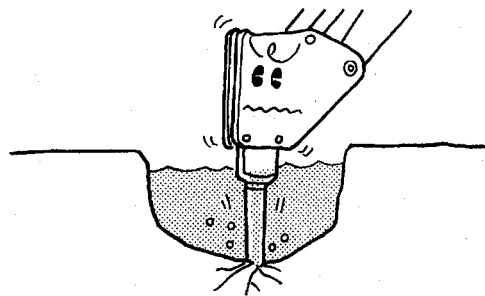

Do not operate with the breaker body under water. It will cause serious damage to the breaker. Only certain models are designed to be used under water but only when a special kit is used. For further information, contact your Takeuchi distributor.

Do not use breaker for lifting the object.

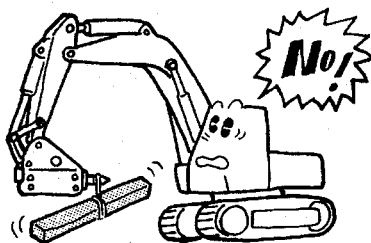

Please do not use breaker, bracket or chisel for lifting or carrying items. It will cause damage and wear to the breaker or excavator front section.

When hydraulic hose swing abnormal...

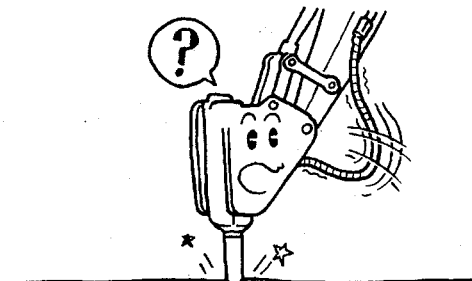

Its cause may be leakage of nitrogen gas from back head gas chamber. In such case, check promptly the gas pressure and fill to the required pressure.

How to Operate the Breaker

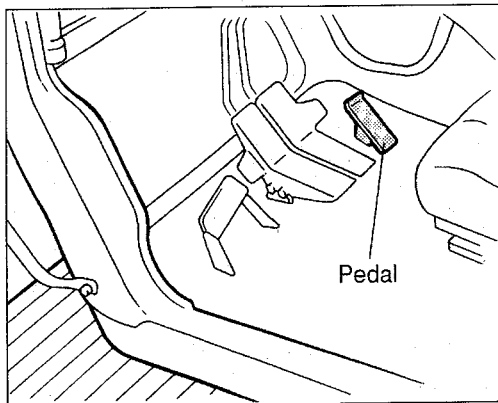

Operation method of breaker

There are two methods for operation, depending on the type of control valve of pump (of excavator).

■ Pedal method (Direct connection system from the pump & Sub-valve system)

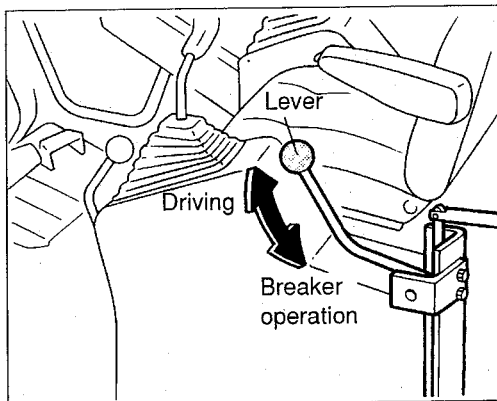

■ Valve switching method. (Switching from drive method.)

Change switching valve (which is on side of drivers seat) to breaker position. Push the driving lever forward to operate the breaker. Change switching valve to the drive position to move excavator forward.

Operation of the breaker

- 1 Apply contact to the material.
- 2 Keep the chisel at perpendicular position, and operate the breaker.
- 3 Stop blowing when the material is broken.

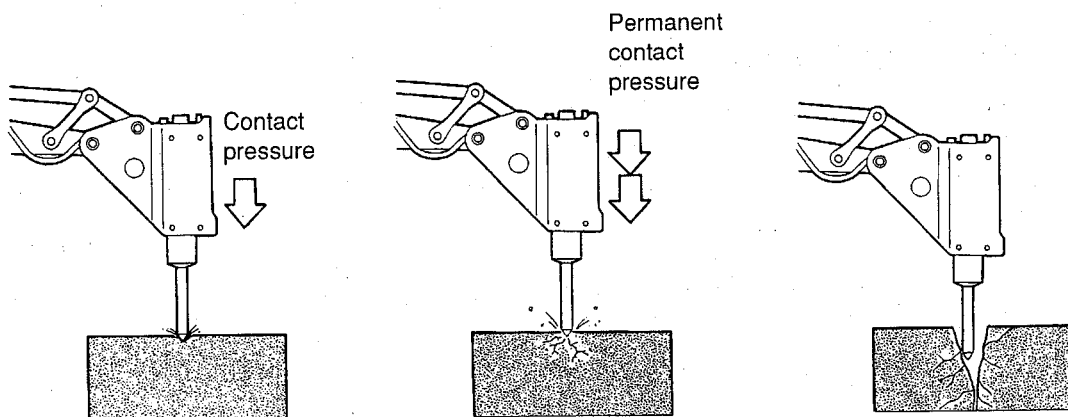

1. Please allow excavator to idle before operating breaker. Check to see if the needle of temp. Gauge is functioning.
2. Set the r.p.m. (revolution per minute) below the designated level.

Removing & Attaching the Breaker

Procedure to remove the breaker

- 1 Position when removing or attaching the breaker.

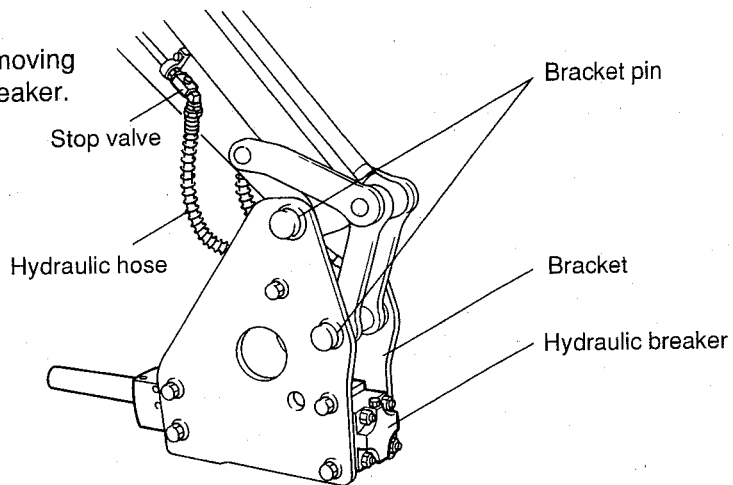

- 2 Turn stop valve to 'off' position.

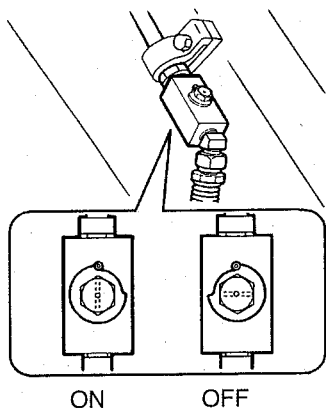

- 3 Remove the hose from piping on the excavator arm.

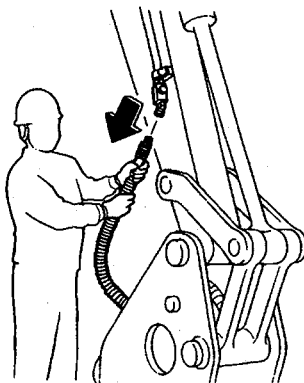

- 4 Remove the two bracket pins.

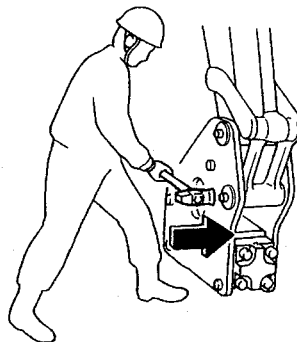

- 5 Raise the excavator arm slowly and thus remove the breaker.

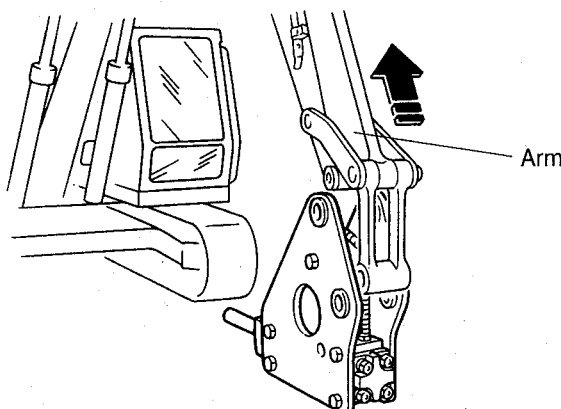

Remember to fit blanking plugs to the ends of the pipes on the excavator and to the hoses on the breaker to prevent dirt etc. from entering.

Removing & Attaching the Breaker

Procedure to attach the breaker

- 1 Adjust the center of breaker bracket and excavator arm. Lower down the arm slowly and align holes.



To adjust the center of breaker bracket and arm, decrease r.p.m. of engine and operate the boom & arm slowly.

- 2 First fix the pin (at arm side) and then fix the pin (at link side) by operating bracket cylinder.
- 3 Remove blanking plugs and connect breaker hoses to the pipes on the excavator.
- 4 Turn stop valve to 'on' position.

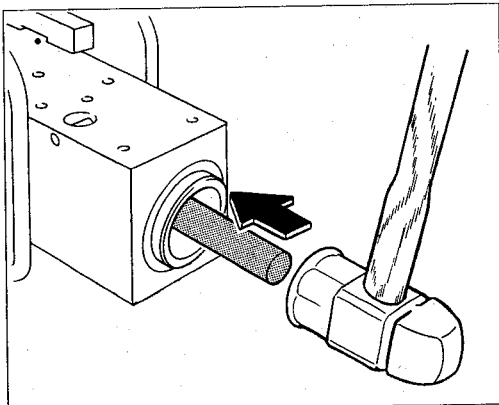
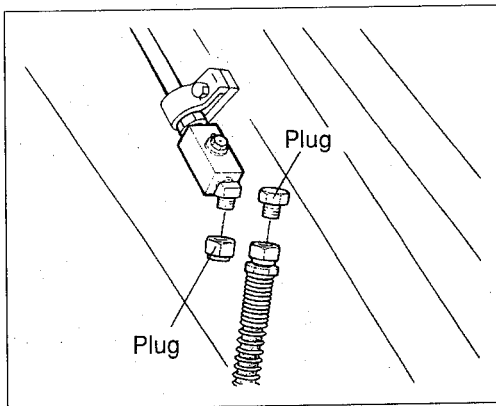

Storage and maintenance of the breaker

When storing the breaker for a long period of time, please observe the following steps.

- 1 Be sure to fix plug to hoses and other metal fittings.
- 2 Release nitrogen gas (in the gas chamber) from the gas valve.
(See page 11 for 'When gas pressure is high')
- 3 Remove chisel.
- 4 Retreat the piston by positioning a suitable bar against the blowing end and strike it with a hammer.



If you loosen the plugs on the hoses, the piston will easily retreat.

- 5 Apply grease to front head section.
(See page 15 for 'greasing')



Caution! Store the breaker in a safe, secure garage or workshop and cover with suitable sheeting to protect from precipitation.

How to Change Chisel

Procedure to remove chisel

- 1 Place the breaker in a horizontal position and remove spring pin by using special pin (in the manner shown in the illustration).

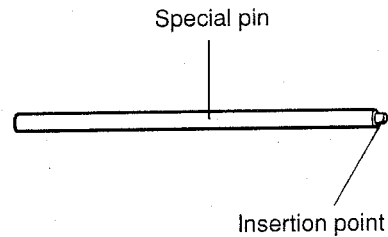
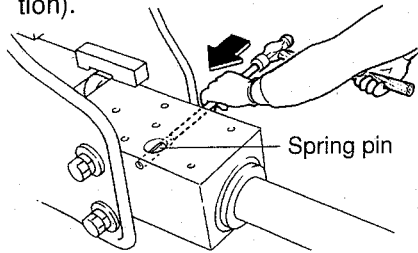

- 2 Remove chisel set pin.

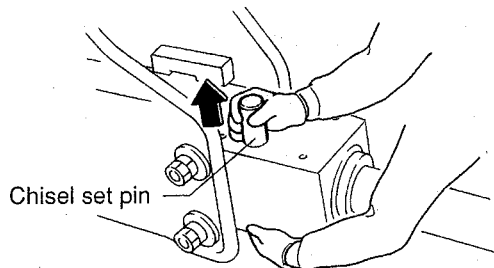

- 3 Remove chisel.

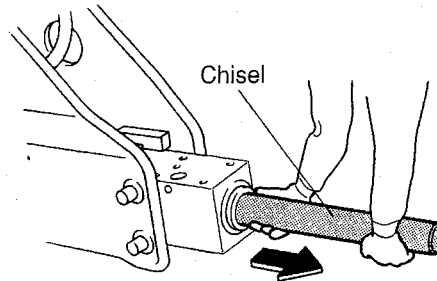

Procedure to attach chisel

- 1 Place chisel on timber blocks as shown in the illustration.

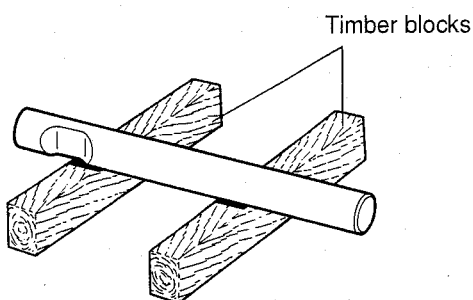

- 2 Coat the contact area of chisel with sufficient grease, and fix the chisel in the reverse order to removing.

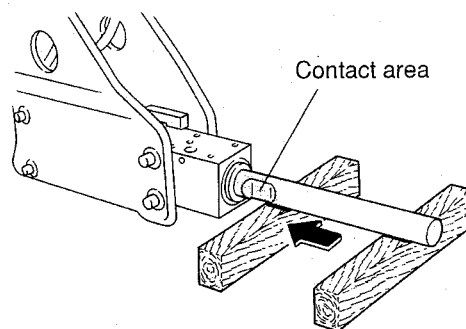

- 3 Insert the chisel set pin and strike spring pin (ensure the slit is facing upwards) into the aperture with hammer.

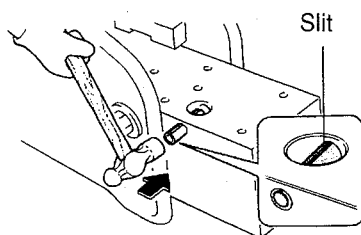

Caution!

- The spring pin must be fitted with the slit facing upwards. Insert in the manner shown in the illustration.
- Use only a genuine Takeuchi hydraulic breaker chisel.

Enclosure of Nitrogen Gas

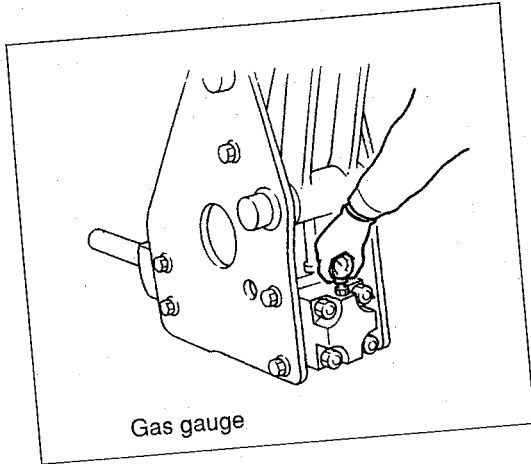

Inspection of gas pressure (Back head gas chamber)

At normal ambient temperature, gas pressure should be in the range of 0.83~1.03 MPa.



- When inspecting the gas pressure, ensure that no contact pressure is applied.
- It is normal for the gas pressure to increase during operation due to the rise in oil temperature. However, when the number of strokes decrease, keep the pressure below 1.08 MPa.

Inspection procedure of sealed gas

- 1 Remove rubber cap from back head.

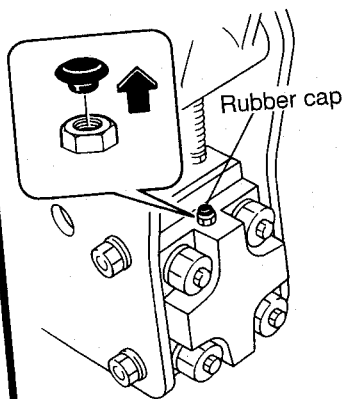

- 2 Insert the gas gauge.

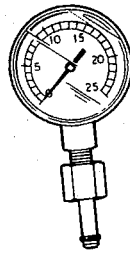

- 3 Read the gas pressure.

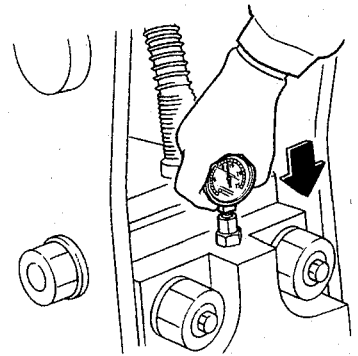

When gas pressure is high:

- 1 Release the gas until the correct pressure is obtained, by inserting a round bar with a diameter of approx. 5mm.
- 2 Fix rubber cap.

Enclosure of Nitrogen Gas

When gas pressure is low (Method to fill gas chamber)

- 1 Connect gas hose ass'y and regulator ass'y to nitrogen gas cylinder as shown in the illustration.

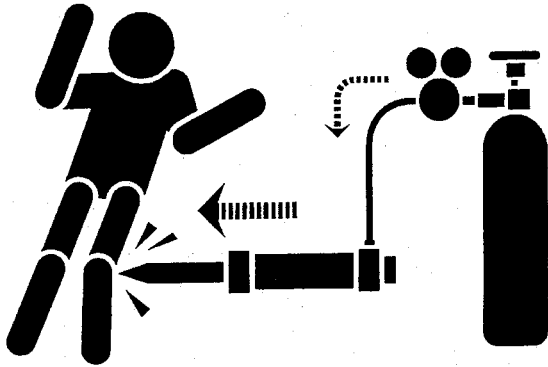

Protrusion of chisel

WARNING

Ensure that nobody is standing in front of the chisel when filling the gas chamber. The increase in gas pressure may cause the chisel to suddenly release itself.

- 2 Loosen the handle of regulator ass'y.
- 3 Open the valve of nitrogen gas cylinder.
- 4 Remove rubber cap of back head and insert gas hose ass'y.

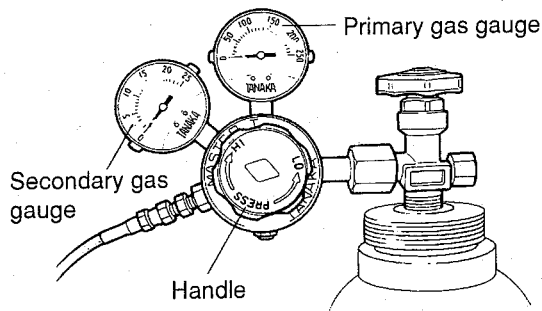

- 5 Tighten the handle of regulator ass'y until secondary gas gauge shows 1.03 MPa.

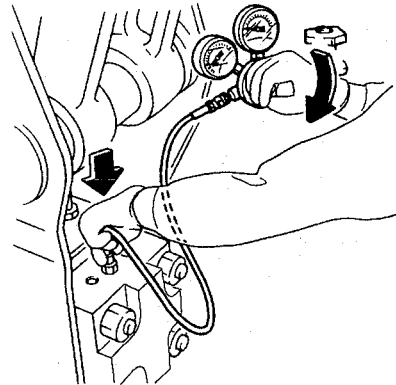

- 6 Fill in the gas for 15 to 20 seconds.
- 7 Loosen the handle to regulator ass'y, and remove gas hose ass'y.
- 8 Confirm gas pressure by checking with gauge. (1.03 MPa)
- 9 Fix the rubber cap.



Caution!

1. When the temperature of the breaker is high, set the gas pressure to 1.13 MPa.
2. When removing regulator ass'y from nitrogen gas cylinder, do so after releasing the remaining pressure by tightening the handle of regulator ass'y. (Confirm gauge reads zero.)
3. Gas other than nitrogen gas should not be used. Use of air or oxygen may result in explosion.
4. Nitrogen gas is filled in a high pressure container at 14.7 MPa as regulated by law. Handle it with care.
5. Nitrogen gas is inflammable. However, do not place it in the vicinity of fire or expose it directly to sunlight.

How to Adjust Operating Pressure by Adjust Plug

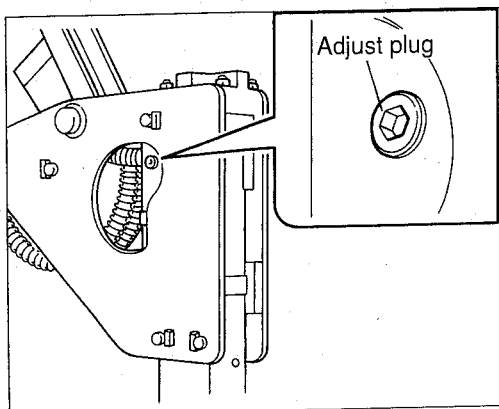

Operating pressure adjustment

Adjusting the operating pressure changes the impact force and number of blows by restricting the oil return path.

	No of Blows	Blowing force
Larger adjust plug	Decrease	Increase
Smaller adjust plug	Increase	Decrease

There will be little difference in the number of strokes with constant-volume-discharge pumps.

Procedure to adjust operating pressure

- ① Install an oil pressure gauge in the high pressure line of excavator.
- ② Turn the adjust screw of relief valve (on excavator) until a reading of 16.17 MPa is obtained.
- ③ Set r.p.m. of engine at full throttle and, operate breaker.
- ④ Read the oil pressure gauge.

When operating pressure is higher than 13.72 MPa:

Decrease the size of adjust plug. If the pressure is still higher than 13.72 MPa, take either of the following steps.

- ① Loosen the adjust screw of relief valve and set the pressure within the designated range.
- ② Decrease the r.p.m. of engine and set the pressure within the range of operating pressure.
- ③ By decreasing the enclosed gas pressure of gas chamber, the operating pressure will be decreased.

When operating pressure is lower than 9.8 MPa.

Make the size of adjust plug larger and set the pressure within the range of operating pressure.

Blowing force	Number of blows	Adjust plug	Part Number	Oil flow rate
Decrease ↓	Increase ↑	ϕ 7mm	TS20-31-0020 (Standard)	35~50 l /min
Increase ↓	Decrease ↑	ϕ 8mm	TS21-31-0030 (Option)	25~35 l /min

Maintenance

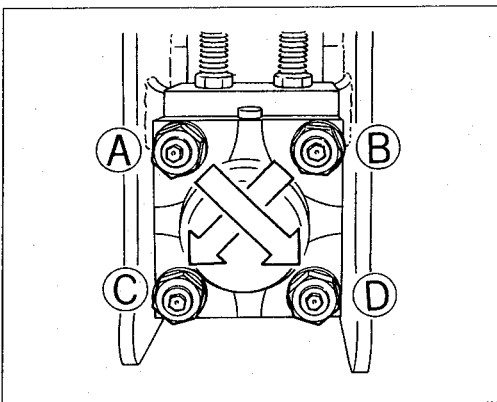
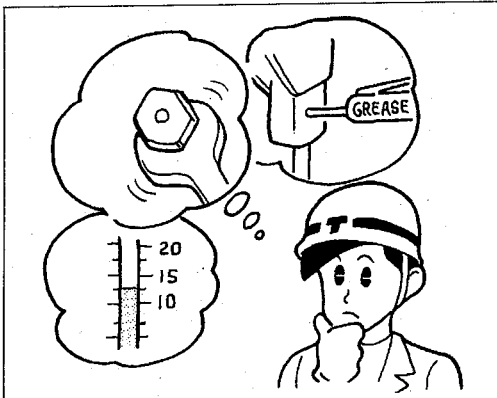

Order of fastening through bolts,
Ext. A→D, B→C

Inspection items

Inspection items	Prior to work	Regular inspection	Remarks
Loosening of bolts	○	○	
Hydraulic oil, oil qty	○	○	Change oil each 600 hrs.
Oil leakage	○	○	
Flaw on the hydraulic hose	○	○	
Grease feeding	○	○	
Breakage of chisel set pin	○		
Clogging of filter		○	Change each 100 hrs.
Gas pressure in the back head gas chamber		○	Gas: 0.83~1.03 MPa

Bolts

Please check all bolts prior to work.
Loose bolts will cause excessive load on other bolts and lead to malfunction. Please tighten up periodically to specified torque.

Name	Tool size	Torque N·m
Through bolt of breaker	Double head wrench 32	490
Adjust plug of breaker	Pin wrench 6	39.2
Gas valve	Single head wrench 24	98
Grease nipple	Box wrench 10	29.4
Bolt fixing bracket and breaker	Double head wrench 32	343
Hose connector of breaker	Single head wrench 27	147



Caution!

When changing more than two thru bolts:

1. Release gas from gas chamber completely.
2. Bolts which are being reused must still be loosened.
3. Tighten bolts in the sequence shown above.

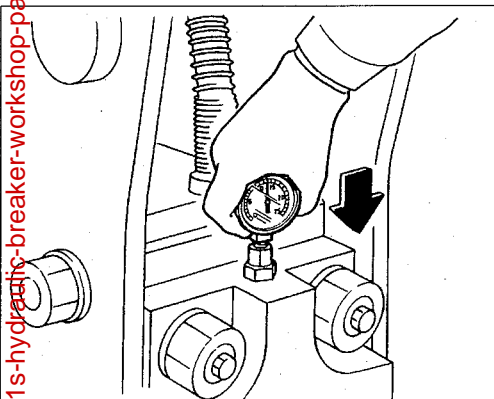

Gas pressure in the back head gas chamber

Blowing force of breaker equals hydraulic energy plus gas pressure of back head gas chamber. Gas pressure of back head gas chamber should be kept within the range of 0.83~1.03 MPa.