

Product: 2013 Kubota WSM KX040-4 Excavator Service Repair Workshop Manual
Full Download: <https://www.arepairmanual.com/downloads/2013-kubota-wsm-kx040-4-excavator-service-repair-workshop-manual/>

WSM

WORKSHOP MANUAL KUBOTA EXCAVATOR

KX040-4

The Kubota logo is displayed in a bold, black, sans-serif font. The letters are thick and blocky, with a distinctive design for the 'K' and 'O's.

Sample of manual. Download All 450 pages at:
<https://www.arepairmanual.com/downloads/2013-kubota-wsm-kx040-4-excavator-service-repair-workshop-manual/>

CONTENTS

TO THE READER

TO THE READER

I INFORMATION

CONTENTS

INFORMATION

1. SAFETY FIRST I-1
2. IN THE INTEREST OF WORK SAFETY I-2
3. LABELS DISPLAYED TO PROMOTE WORK SAFETY I-6
4. MAIN SPECIFICATIONS I-13
5. DIMENSIONS I-14

G GENERAL

CONTENTS

GENERAL

1. CHECKING EXCAVATOR IDENTIFICATION G-1
2. ENGINE IDENTIFICATION G-2
3. MUFFLER FULL ASSEMBLY IDENTIFICATION G-5
4. GENERAL PRECAUTIONS G-7
5. HANDLING PRECAUTIONS FOR ELECTRICAL PARTS AND WIRING G-11
6. TIGHTENING TORQUES G-16
7. OIL AND WATER CAPACITY TABLE G-20
8. MAINTENANCE INTERVALS G-21

1 MACHINE BODY

CONTENTS

SERVICING

1. FRONT 1-S1
2. SWIVEL FRAME 1-S5
3. TRACK FRAME 1-S18
4. MEASURING MACHINE PERFORMANCE 1-S30
5. SWIVEL GEAR BACKLASH PERFORMANCE 1-S32

2 ENGINE

CONTENTS

GENERAL

1. SPECIFICATIONS 2-G1
2. DIMENSIONS 2-G2
3. PERFORMANCE CURVES 2-G3

3 HYDRAULIC SYSTEM

CONTENTS

MECHANISM

1. HYDRAULIC CIRCUIT DIAGRAM 3-M1
2. PUMP 3-M4
3. CONTROL VALVES 3-M12
4. SWIVEL MOTOR 3-M25
5. TRAVEL MOTOR 3-M29
6. HYDRAULIC CYLINDER 3-M38
7. PILOT VALVE 3-M41
8. SOLENOID VALVE 3-M51

SERVICING

1. PUMP 3-S1
2. CONTROL VALVE 3-S4

3. SWIVEL MOTOR 3-S6
4. SWIVEL JOINT 3-S15
5. TRAVEL MOTOR 3-S22
6. HYDRAULIC CYLINDER 3-S40
7. PILOT VALVE (CONTROL) 3-S42
8. SOLENOID VALVE 3-S77
9. ROUTING OF HYDRAULIC HOSES 3-S80
10. MEASURING HYDRAULIC DEVICE PERFORMANCE 3-S103
11. HYDRAULIC DEVICE PERFORMANCE STANDARDS 3-S127
12. TROUBLESHOOTING 3-S133

4 ELECTRICAL SYSTEM

CONTENTS

SERVICING

1. ELECTRICAL DEVICE LAYOUT AND WIRING CIRCUIT 4-S1
2. METER PANEL OPERATION 4-S3
3. INSPECTIONS 4-S37
4. TROUBLESHOOTING (START-UP EQUIPMENT VERSION) 4-S43
5. METHODS FOR DIAGNOSING ERRORS 4-S44
6. TROUBLESHOOTING (METER PANEL VERSION) 4-S46

5 CABIN

CONTENTS

MECHANISM

1. AIR CONDITIONING SYSTEM 5-M1
2. WIPER 5-M17

SERVICING

1. TROUBLESHOOTING 5-S1
2. MAINTENANCE AND SERVICE RELATED SPECIFICATIONS 5-S4
3. TORQUE 5-S5
4. PRECAUTIONS WHEN REPAIRING THE REFRIGERANT SYSTEM 5-S6
5. INSPECTING AND CHARGING THE REFRIGERANT SYSTEM 5-S11
6. INSPECTION AND DISASSEMBLY 5-S20
7. WINDOW WASHER 5-S35
8. REMOVAL AND INSTALLATION OF GLASS 5-S37
9. FRONT WINDOW 5-S42

TO THE READER

This Workshop Manual provides service personnel with information about the mechanisms, service and maintenance of the construction machinery. This Workshop Manual is divided into 3 sections, General, Mechanisms and Service.

■ General

This section contains information such as engine and equipment ID numbers, general precautions, maintenance schedules, inspections and maintenance items and special tools.

■ Mechanisms

This section describes the structure of mechanisms and explains their functions. Be sure that you fully understand this Mechanisms section prior to performing any service work, such as troubleshooting or when performing any disassembly or assembly work.

■ Service

This section contains information and procedures for performing maintenance on the backhoe, such as troubleshooting, service specification tables, torque specifications, items to be inspected and adjusted, disassembly and assembly procedures, as well as precautions, maintenance standard values and usage limits.

All of the illustrations, specifications and other information in this manual were created based on the latest model at the time of publication.

Please be aware that changes to the content may be made without prior notice.

■ NOTE

- Corresponding model list

Machine Model	Engine Model
KX040-4	D1803-CR-TE4-BH

© KUBOTA Corporation 2013

January, 2013

| INFORMATION

INFORMATION

CONTENTS

1. SAFETY FIRST	I-1
2. IN THE INTEREST OF WORK SAFETY	I-2
[1] WORKING SAFELY WITH THE EQUIPMENT MEANS ALWAYS FOLLOWING THESE INSTRUCTIONS:.....	I-2
(1) Precautions Before Working on the Mini-Excavator	I-2
(2) Precautions Before Working on the Equipment.....	I-3
3. LABELS DISPLAYED TO PROMOTE WORK SAFETY	I-6
[1] LOCATIONS.....	I-6
[2] LABEL MAINTENANCE	I-12
4. MAIN SPECIFICATIONS.....	I-13
5. DIMENSIONS	I-14

1. SAFETY FIRST

SAFETY FIRST

- This "Safety Alert Symbol" is used in this manual and on labels on equipment to indicate important issues and warn of the danger of personal injury. Read and follow these warnings carefully.
- It is important that you thoroughly read these instructions and safety rules prior to working on the equipment and that you always follow them.

DANGER

- Indicates that failure to follow the warning will result in serious injury or death.

WARNING

- Indicates that failure to follow the warning may result in serious injury or death.

CAUTION

- Indicates that failure to follow the warning may result in injury.

■ IMPORTANT

- Indicates that failure to follow the warning may result in damage to or a breakdown of the equipment.

■ NOTE

- Indicates supplementary explanations that will be helpful when using the equipment.

[NOTE]

- Indicates other supplementary information to take note of.

RY9212001INI0001US0

2. IN THE INTEREST OF WORK SAFETY

[1] WORKING SAFELY WITH THE EQUIPMENT MEANS ALWAYS FOLLOWING THESE INSTRUCTIONS:

(1) Precautions Before Working on the Mini-Excavator

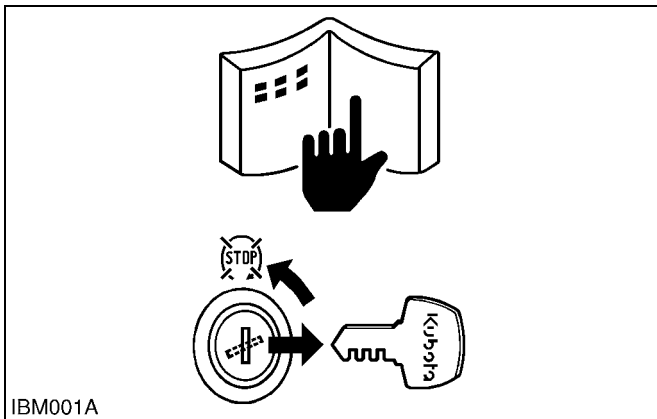

Before starting any service or maintenance work,

- Read all the general and safety instructions in this manual, as well as the decals on your equipment.
- Always stop the engine whenever you leave the driver's seat to inspect or clean the machine or its devices, or to inspect or adjust parts.
- Choose a safe spot for inspecting the equipment-on flat, hard ground.

RY9212001INI0002US0

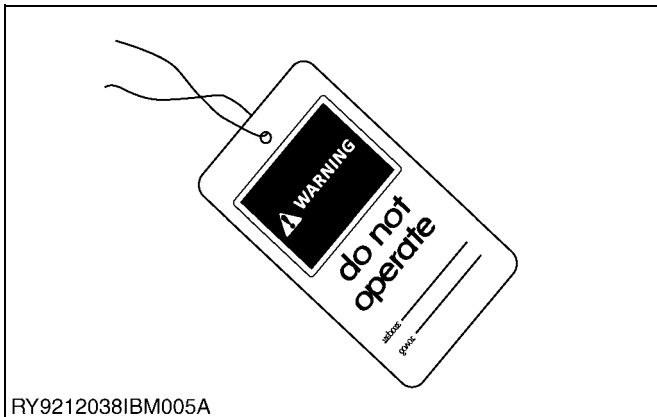

- When performing maintenance on the equipment, hang the DO NOT OPERATE sign where it will be obvious from and around the driver's seat.
- When performing maintenance or repairs, always lower attachments to the ground, stop the engine and set the brake.
- When performing maintenance on the equipment, always disconnect the negative battery cable.
- Before using tools, make sure you understand how to use them correctly and use tools in good condition and of the right size for the job.

RY9212001INI0003US0

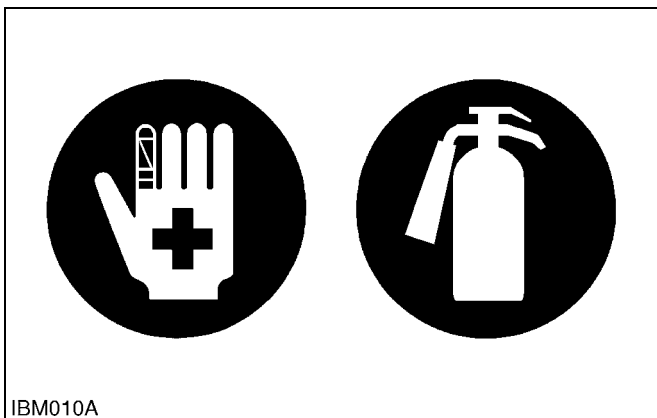

Be Ready for an Emergency

- Keep a first-aid kit and fire extinguisher close at hand so you can use it when needed.
- Keep emergency contact information for doctors, hospitals and ERs handy.

RY9212001INI0004US0

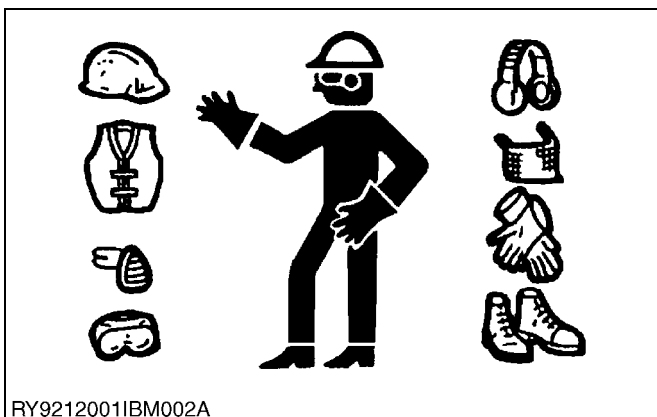

- Wear clothes appropriate for working on equipment. Do not wear loose-fitting clothes as they may catch on the machine controls.
- When working on the equipment, use all safety gear, such as a helmet, safety glasses and shoes, that are required by law or regulation.
- Never perform maintenance while drowsy or under the influence of alcohol or drugs.

RY9212001INI0005US0

(2) Precautions Before Working on the Equipment

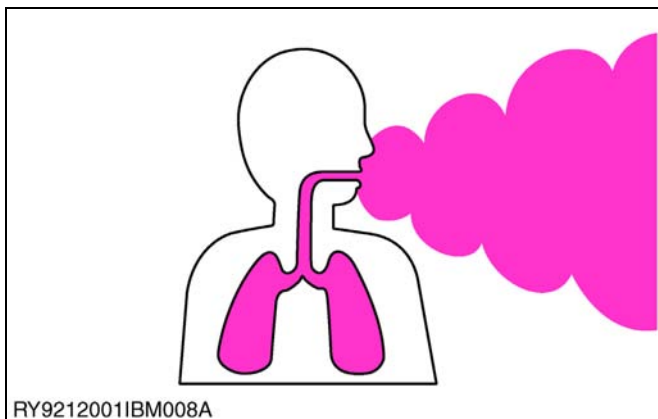

- Stop the machine on a hard and level location and make sure the area around the machine is free of obstacles and hazardous materials. When parking the machine indoors, select a spot that can be properly ventilated.
- When performing work such as with a hammer, fragments may go flying, so make sure only authorized persons are around the machine.
- Before servicing the machine, clean it off so there is no mud, debris, oil or the like sticking to it.

R9212001INI0006US0



- Before getting on/off of the machine, clean off around the steps so there is no mud on them. Always give yourself 3-point support when getting on/off the machine.

CAUTION

- **3-point support means using both legs and one hand or both hands and one leg as you climb up/down.**

R9212001INI0007US0



Starting the Machine Safely

- Before starting the engine, always sit in the driver's seat and make sure the area is safe and clear.
- As it is dangerous, never start the engine from anywhere but the driver's seat.
- Always check and make sure control lever(s) are not engaged before starting the engine.
- Never start the engine by hot-wiring the starter circuit. This is not only dangerous, but may damage the machine.

R9212001INI0008US0

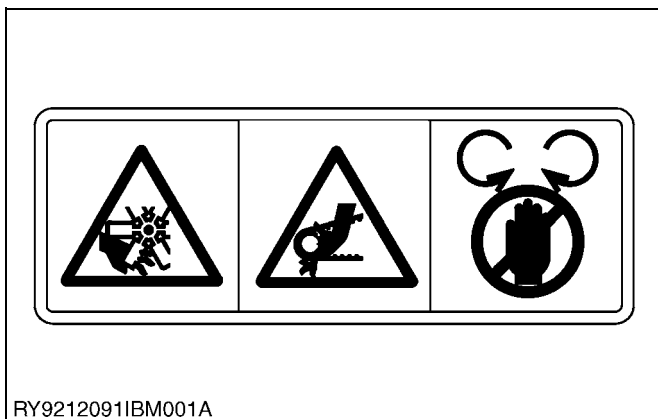

- Whenever it is necessary to open the engine covers or hood in order to service the machine, always prop them open.
- If it is absolutely necessary to run the engine while working on the machine, make sure you are clear of all rotating or moving parts. Also take care not to leave anything, such as tools or rags, near any moving parts.

R9212001INI0009US0



- The engine, muffler, radiator, hydraulic line, etc., have parts that remain very hot even after the engine has been stopped. Be sure to avoid these parts, as touching them can result in burns. Radiator coolant, hydraulic fluid and oil also remain hot. Therefore, do not attempt to remove caps and plugs, etc., before these fluids have sufficiently cooled.
- Make sure the coolant temperature has dropped sufficiently before opening the radiator cap. Also, since the inside of the radiator is pressurized, when removing the cap, first loosen it to release the pressure before removing the cap completely.

RY9212001INI0016US0

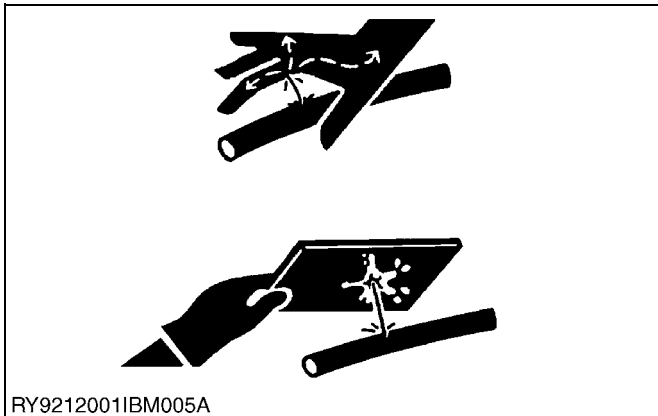

- The pressure in the hydraulic circuit stays at pressure even after the engine stops. Before removing parts, such as hydraulic devices from the machine, first release the pressure. Please note that when releasing residual pressure, the machine itself and/or implements may move without warning, so be very careful when releasing the pressure.
- Oil gushing out under pressure is extremely dangerous as it may pierce your skin or your eyes. Similarly, oil leaking out of pinholes is not visible. So when checking for oil leaks, always wear safety glasses and gloves and use a piece of cardboard or a wood block to shield yourself from oil.

RY9212001INI0011US0

No Smoking or Open Flames while Fueling



- Fuel is extremely flammable and dangerous. Never smoke near fuel. If fuel is spilled on the machine, its engine, or electrical parts, it may cause a fire. If fuel is spilled, wipe it all up immediately.
- Never smoke while filling the machine with fuel. And always tighten the fuel cap securely and wipe up any spilled fuel.

RY9212001INI0012US0

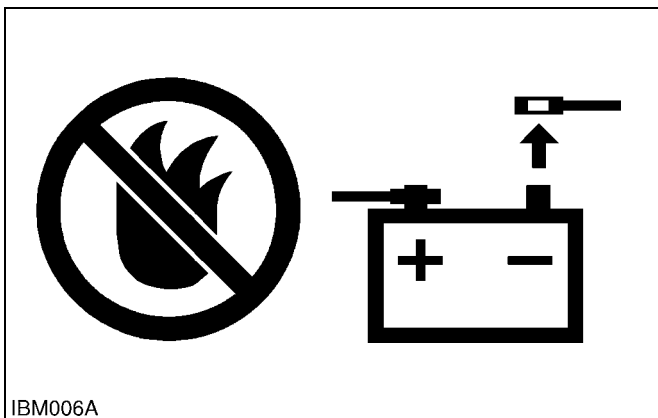

- Always wear safety glasses and gloves when handling the battery.
- The gas generated by the battery is flammable. Never weld or use tools like a grinder near the battery. And never smoke near it.
- When disconnecting the battery, always disconnect the negative cable first. When connecting the battery, always connect the positive cable first.

RY9212001INI0013US0



- Grease is under high pressure inside the hydraulic cylinder. It is very dangerous to loosen a grease nipple quickly as it may shoot off. Always loosen grease nipples slowly.
- And never face a grease nipple while loosening it.

RY9212001INI0014US0



Dispose of Waste Fluids Properly

- Never dispose of waste fluids on the ground, in the gutter, a river, pond or lake. Always dispose of hazardous substances like waste oil, coolant and electrolytic fluid in accordance with the relevant environmental protection regulations.
- Keep the safety plates clean so they can be read. If a safety plate is damaged and comes off or becomes illegible, put a plate with the same warnings back in its place.

RY9212001INI0015US0

3. LABELS DISPLAYED TO PROMOTE WORK SAFETY

[1] LOCATIONS

(1)

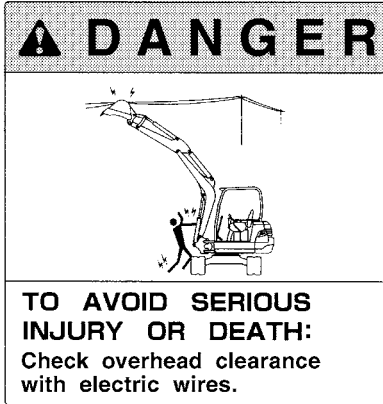

1BAAAQAP0800

(2)

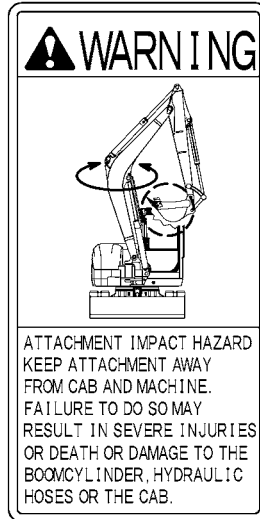

1BAAAARAP1000

(3)

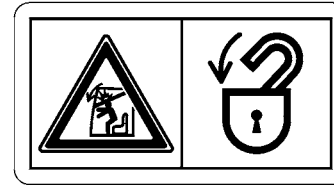

1BAAAABYAP158E

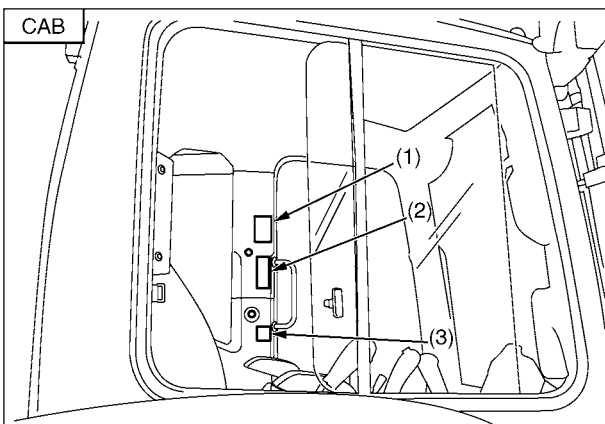

RY9212174ICI001A

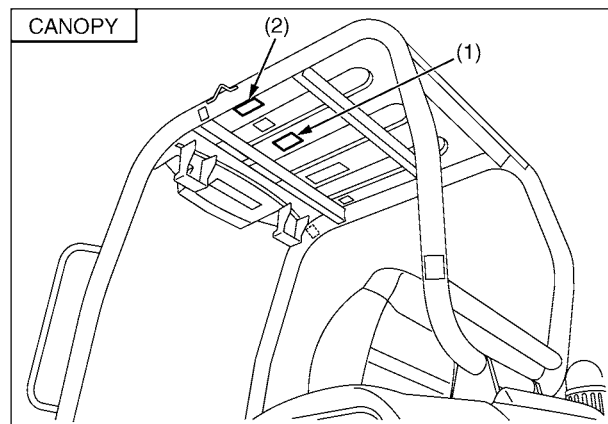

RY9212174INI0001US0

(1)

CAUTION

IMPORTANT

TO AVOID PERSONAL INJURY :

1. Read and understand operator's manual before attempting to start or operate the excavator. Read the manual of the attachment to do a correct operation safely when other attachments are installed instead of Kubota specified bucket.
2. Before starting engine, make sure all control levers are in neutral and the operating area is clear of all bystanders.
3. Never allow passengers on any part of the excavator while operating.
4. Know your work area before starting operation.
 - Check underground lines and cables.
 - Stay off slopes too steep for safe operation.
5. Check for hidden holes, obstacles or drop-offs and overhangs.
6. Make sure all shields are in place and securely fastened.
7. Before dismantling from the machine, lower all attachment to the ground, stop the engine and remove the key.
8. Damaged ROPS must be replaced, not repaired or revised.

Never use boom, dipper, or bucket to hammer or beat sideways. Excavator is not intended for these usages.

1BAABBAP120E

(2)

CAUTION

TO AVOID PERSONAL INJURY :

STOP

Do not open engine hood before stopping engine. Only when engine does not stop with the key. Pull back this stop button and hold it until the engine stops.

1BAABYAP116E

(3) [CAB]

WARNING

← TRAVEL DIRECTION →

Drive levers

FRONT

DOZER BLADE

TO AVOID PERSONAL INJURY OR DEATH:
Before moving the excavator, KNOW THE LOCATION OF THE DOZER BLADE. The excavator will travel in the direction of the dozer blade when drive levers are moved away from the operator.

DO NOT OPERATE WITHOUT ROPS. YOU COULD BE CRUSHED.

USE SEAT BELT

1BAABBAP119E

(3) [CANOPY]

WARNING

← TRAVEL DIRECTION →

Drive levers

FRONT

DOZER BLADE

TO AVOID PERSONAL INJURY OR DEATH:
Before moving the excavator, KNOW THE LOCATION OF THE DOZER BLADE. The excavator will travel in the direction of the dozer blade when drive levers are moved away from the operator.

DO NOT OPERATE WITHOUT ROPS. YOU COULD BE CRUSHED.

USE SEAT BELT

1BAAAQAP0790

(4)

WARNING

TO AVOID PERSONAL INJURY OR DEATH
Do not push the dozer control lever into the float position while the machine is supported by the dozer blade.

1BAABYAP120E

(4) Angle blade type

WARNING

TO AVOID PERSONAL INJURY OR DEATH
Do not push the dozer control lever into the float position while the machine is supported by the dozer blade.

1BAAGACAP072E

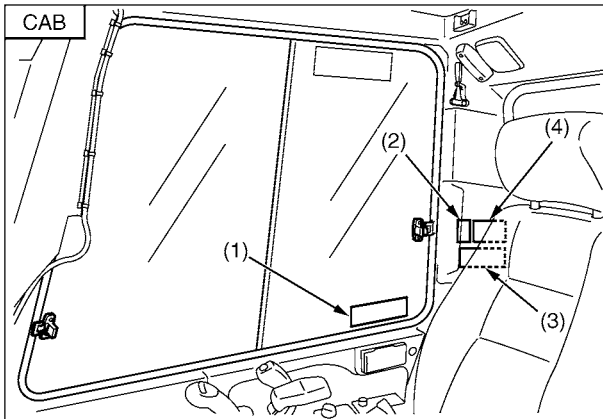

RY9212174ICI002A

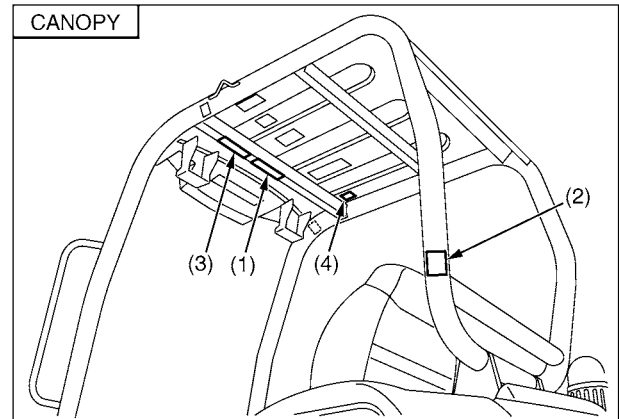

RY9212174INI0002US0

(1) [CAB]

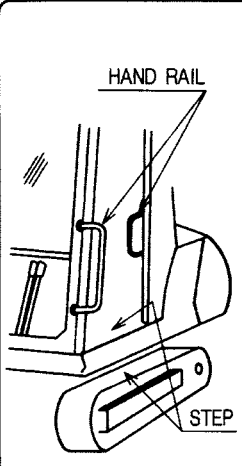

CAUTION

TO AVOID PERSONAL INJURY:
MOUNT AND DISMOUNT SAFELY
WHEN ENTERING OR LEAVING
THE OPERATOR'S COMPARTMENT.

1. Maintain a three-point contact with the steps and handrails.
2. Face the machine.
3. Never jump on or off the machine.
4. Never attempt to mount or dismount a moving machine.
5. Never use control levers as handles.

1BAAGAAAP0140

(1) [CANOPY]

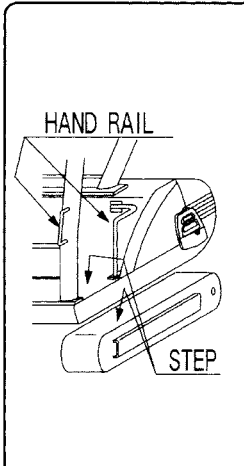

CAUTION

TO AVOID PERSONAL INJURY:
MOUNT AND DISMOUNT SAFELY
WHEN ENTERING OR LEAVING
THE OPERATOR'S COMPARTMENT.

1. Maintain a three-point contact with the steps and handrails.
2. Face the machine.
3. Never jump on or off the machine.
4. Never attempt to mount or dismount a moving machine.
5. Never use control levers as handles.

1BAAGAAAP0160

(2)



CAUTION

TO AVOID PERSONAL INJURY:
Lock control lever before
leaving compartment.

1BAAABYAP138E

(3)

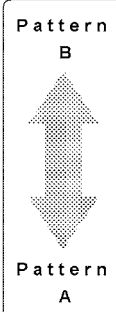

CAUTION

TO AVOID PERSONAL INJURY:

1. Study control lever pattern A and pattern B. Then choose the one which is most familiar.
2. Position the pattern selector lever in either the lowered position (pattern A) or the upward position (pattern B).
3. Engage lever lock to prevent accidental pattern change.
4. Familiarize yourself with the pattern selected by operating slowly.

1BAAGAAAP0170

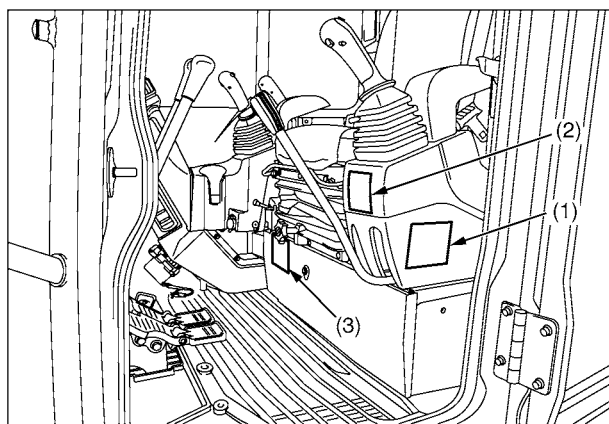

RY9212174IC1003A

RY9212174INI0003US0

(1) Diesel fuel only No fire

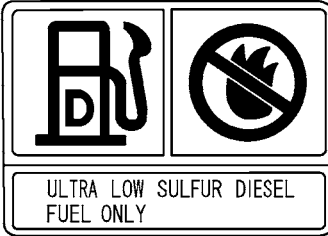

1BAAGAAAP1810

(2) Do not allow any persons within the working range.

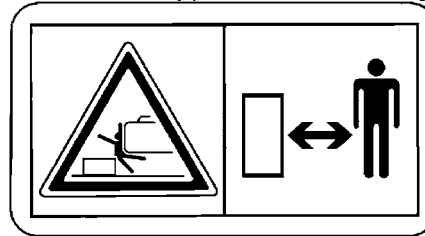

1BAAEAJAP069A

(3)

⚠ DANGER

TO AVOID PERSONAL INJURY OR DEATH FROM A MACHINE RUNAWAY.

1. Do not start engine by shorting across starter terminals.
2. Start engine only from operator's seat.

1BAAGAAAP0250

(5)

⚠ CAUTION

NO STEP

1BAAGAAAP0310

(4)

⚠ CAUTION

TO AVOID PERSONAL INJURY
NEVER OPEN BEFORE
STOPPING ENGINE

1BAAGAAAP0260

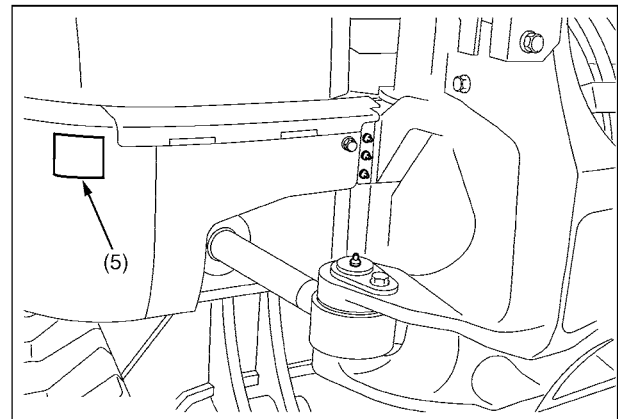

(6)

⚠ CAUTION

TO AVOID PERSONAL INJURY:
When the Diesel Particulate Filter (DPF) is in the regenerating mode, the exhaust gas and the DPF muffler become hot. During regeneration, take into account that the muffler will be very hot and keep the machine away from other people, animals, plants, and flammable material. Also keep the area near the DPF muffler clean and away from flammable material.

1BCAAAAP2180

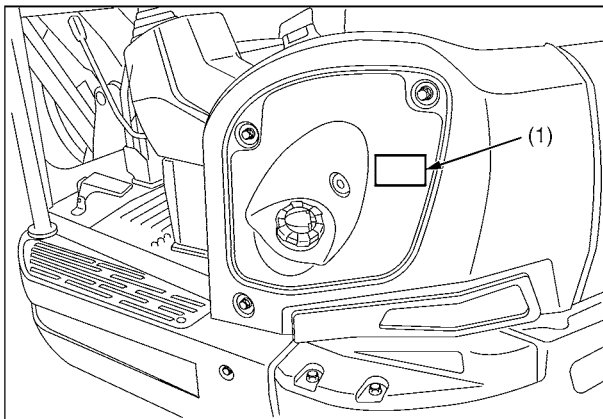

RY9212174IC1004A

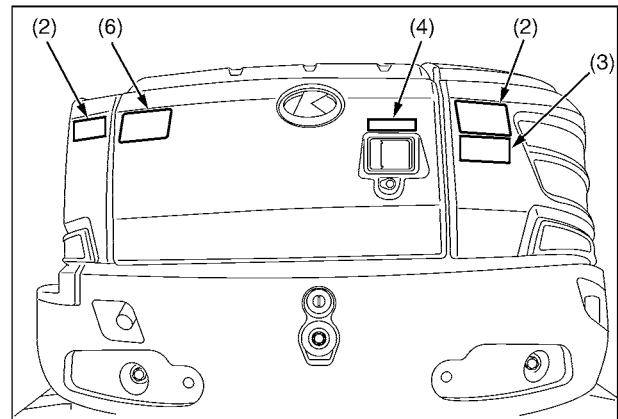

RY9212174INI0004US0

(1) Do not touch hot parts such as exhaust etc.

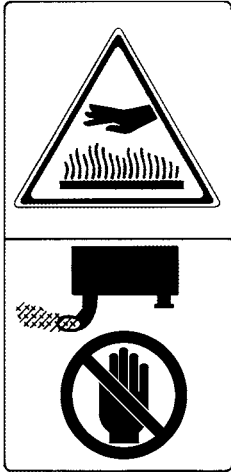

1BAAAADAP0810

(2) Keep away from fan and fan belt.



1BAAAQAP0880

(3)

▲ DANGER/POISON KEEP OUT OF REACH OF CHILDREN. DO NOT TIP. DO NOT OPEN BATTERY.

SHIELD EYES. EXPLOSIVE GASES CAN CAUSE BLINDNESS OR INJURY. S.C.C INDICATOR

NO SPARKS. FLAMER. SMOKING. SEVERE BURNS.

SULFURIC ACID. CAN CAUSE BLINDNESS OR SEVERE BURNS.

FLUSH EYES IMMEDIATELY WITH WATER. GET MEDICAL HELP FAST.

PROPOSITION 65 WARNING
BATTERY POSTS, TERMINALS, AND RELATED ACCESSORIES CONTAIN LEAD AND LEAD COMPOUNDS, CHEMICALS KNOWN TO THE STATE OF CALIFORNIA TO CAUSE CANCER AND REPRODUCTIVE HARM. WASH HANDS AFTER HANDLING.

90D26L 12V 52Ah (5HR) RC125 (MIN) 65Ah (20HR) 680CCA (SAE) 680CCA (EN)

Pb

DK 65746

(4)

▲ CAUTION

TO AVOID SCALDING
Stop engine and allow radiator to cool before opening cap.

1BAAAQAP0890

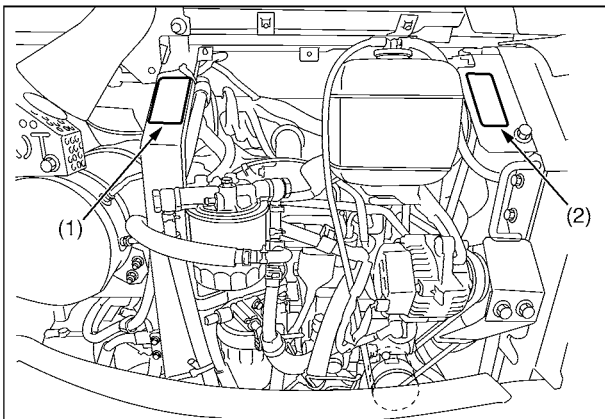
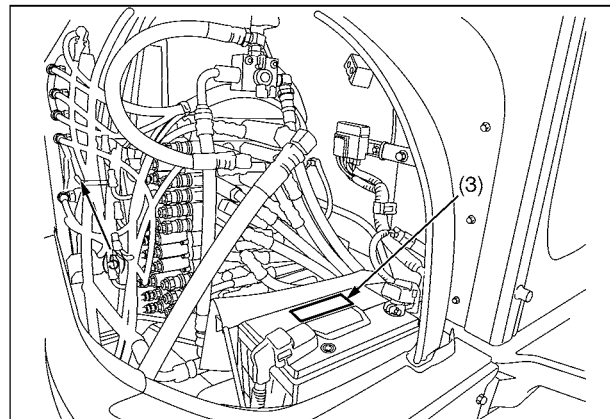

RY9212174IC1005A

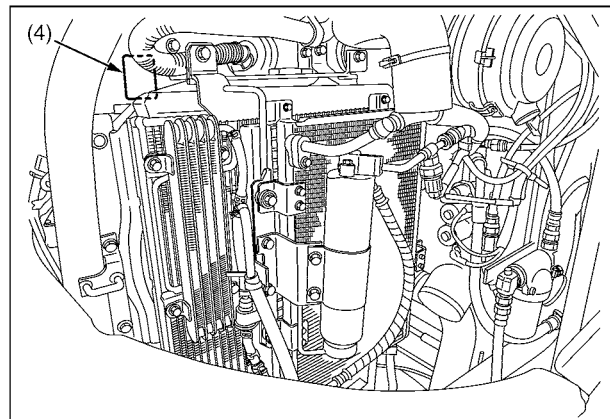

RY9212174INI0005U0

- (1) Do not loosen the grease nipple completely or too quickly.

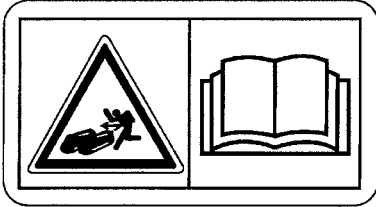

1BAABAMAP0010

- (2) [Both sides]

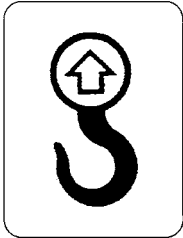

1BAAAAQAP0940

- (3) [Both sides]

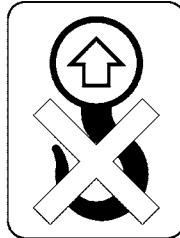

1BAABAUAP2720

- (4) [Both sides]



1BAAGAAP0270

- (5) [CAB]



1BAAABYAP137E

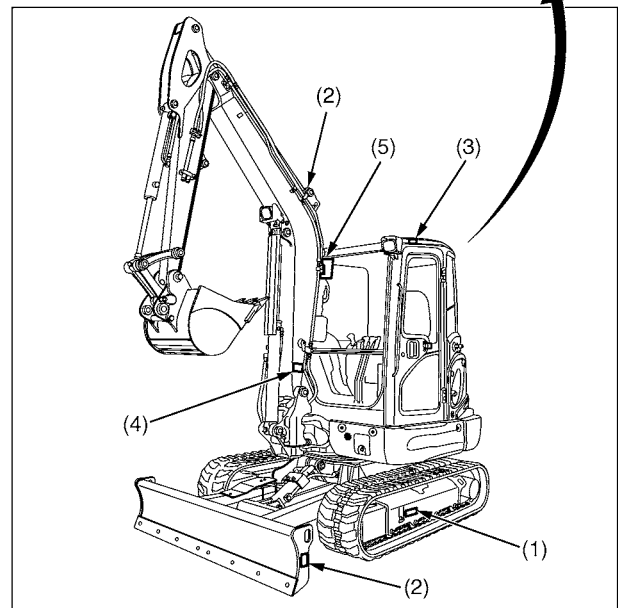
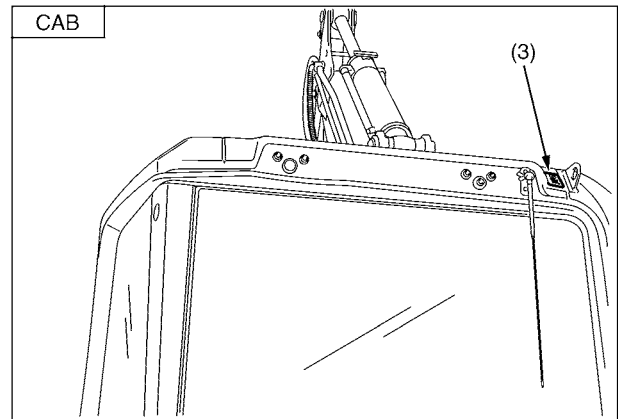
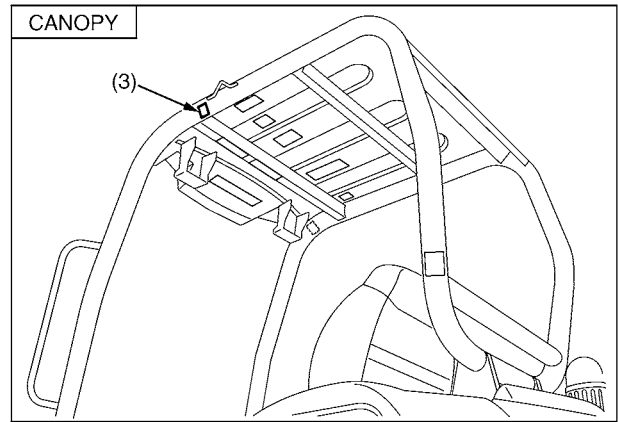

RY9212174ICI006A

RY9212174INI0006US0

(1)

TO AVOID PERSONAL INJURY OR DEATH:

- Do not move raised load over people.
- It is forbidden to lift loads greater than those values mentioned in the lifting capacity tables.
- The values mentioned in this table are valid only on even, hard grounds. When lifting on soft ground, the machine can tilt over due to the fact that the load is concentrated only on one side of the machine.
- The table values are calculated at the end of the arm without the bucket. In order to find the allowable loads for machines with bucket, the bucket weight must be subtracted from the values in the table.

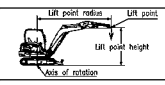

⚠ WARNING

1. The lifting capacities are based on ISO 10567 and do not exceed 75% of the static lift load of the machine or 87% of the hydraulic lifting capacity of the machine.

2. The strokes are as follows:

- 1) The load point corresponds to the front ball part of the arm.
- 2) The machine positions are (f) over-front (Stide down), (g) over-front (Stide up), and (h) over-side.
- 3) The operating cylinder is the boom cylinder.
3. The bucket of the excavator, the hook, the sling and other lifting accessories are taken into consideration for the loads.

LIFT POINT HEIGHT (ft)	LIFTING CAPACITY OVER-FRONT SLADE DOWN Unit=1000lbs					LIFTING CAPACITY OVER-FRONT SLADE UP Unit=1000lbs					LIFTING CAPACITY OVER-SIDE Unit=1000lbs				
	LIFT POINT RADIUS (ft)					LIFT POINT RADIUS (ft)					LIFT POINT RADIUS (ft)				
	MIN	6	10	14	MAX	MIN	6	10	14	MAX	MIN	6	10	14	MAX
12															
8			1,81	1,66	1,67			1,81	1,41	1,25			1,81	1,26	1,11
4			2,59	1,86	1,71			2,23	1,36	1,14			1,95	1,21	1,02
GL	0	2,47	3,09	2,01	1,78	2,47	2,11	1,32	1,18		2,47	1,84	1,17	1,04	
	-4	3,30	5,43	2,89		3,30	4,91	2,10		3,30	4,05	1,83			
	-8		2,78				2,78					2,78			

Machine with ROPS canopy and rubber crawler, without bucket.

1BAAAADAP0820

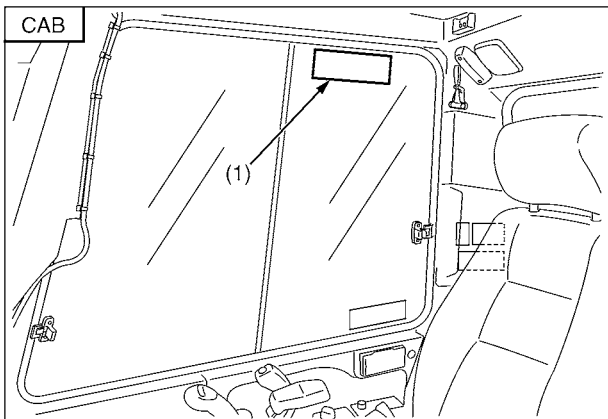

RY9212174IC1007A

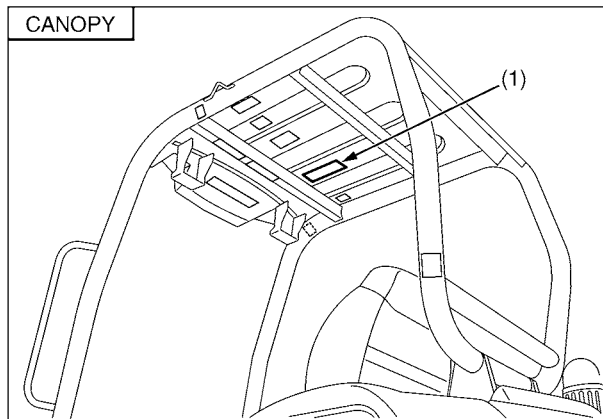

RY9212174INI0009US0

[2] LABEL MAINTENANCE

Thoroughly Read, Understand and Follow Safety Precautions on Labels

- Always keep labels in a clean, undamaged state.
- If labels get dirty, wipe them off with soapy water and a soft cloth.
If solvents such as paint thinner or engine oil are used, the text and or figures may fade away.
- When using a pressure washer to clean the equipment, do not spray any labels directly as doing so may make them peel off.
- If a label is damaged or lost, order a new one from your dealer and affix it as before.
- Before affixing a new label, completely wipe off any dirt or grime on the surface, allow it to dry and then affix in the same place.
- When replacing a part that has a label on it, replace the label at the same time.

RY9212001INI0018US0

4. MAIN SPECIFICATIONS

		KUBOTA EXCAVATOR			
Model name		KX040-4			
Type		CANOPY	CAB	Angle Blade type	
				CANOPY	CAB
Operating weight (including operator's weight)		4170 kg 9193 lbs	4310 kg 9502 lbs	4330 kg 9546 lbs	4470 kg 9855 lbs
Engine	Type	Water cooled 4 cycle diesel engine with 3 cylinder			
	Model name	D1803-CR-TE4 -BH1	D1803-CR-TE4 -BH2	D1803-CR-TE4 -BH1	D1803-CR-TE4 -BH2
	Total displacement	1826 cc (111.4 cu.in.)			
	Engine power SAE J1955 gross	30.1 kW (40.4 Hp)			
	Rated speed	2200 rpm			
	Low idling speed	1150 rpm			
Performance	Unit swing speed	9.2 rpm			
	Travel speed	Fast	5.0 km / h (3.1 mph)		
		Slow	2.9 km / h (1.8 mph)		
	Ground pressure (With operator)	30.4 kPa (0.310 kgf/cm ²) 4.41 psi	31.4 kPa (0.320 kgf/cm ²) 4.55 psi	31.7 kPa (0.323 kgf/cm ²) 4.60 psi	32.7 kPa (0.334 kgf/cm ²) 4.75 psi
	Max. climbing angle	*36 % (20 deg)			
Angle in case of crossing slope	*27 % (15 deg)				
Blade	Width x Height	1700 x 350 mm 66.9 x 13.8 in.		1700 x 385 mm 66.9 x 15.2 in.	
	Max swing	Left	-		0.44 rad (25 deg)
		Right	-		0.44 rad (25 deg)
Boom swing angle	Left	1.20 rad (70 deg)			
	Right	0.96 rad (55 deg)			
Pressure connection for attachments	Max. displacement (Theoretical)	65 L (17 U.S.gal) / min (AUX1 port) 37 L (9.8 U.S.gal) / min (Thumb port)			
	Max. pressure	17.2 MPa (175 kgf/cm ² , 2500 psi) (AUX1 port) 17.2 MPa (175 kgf/cm ² , 2500 psi) (Thumb port)			
Fuel tank capacity		64 L (17 U.S.gal)			

NOTE

- Above dimensions are based on the machine with QUICK HITCH BUCKET.
- Above dimensions are based on the machine with rubber track.
- Specifications subject to change without notice.
- With unloaded digging bucket.
- Firm compacted soil.
- Operators must exercise extra caution and follow instructions in the operator's manual.
- Worse condition or heavier attachment to the above will decrease climbing angle.
- ROPS/FOPS structure complies with ISO 3471, ISO 3449 and OSHA regulations.

RY9212174INI0007US0

5. DIMENSIONS

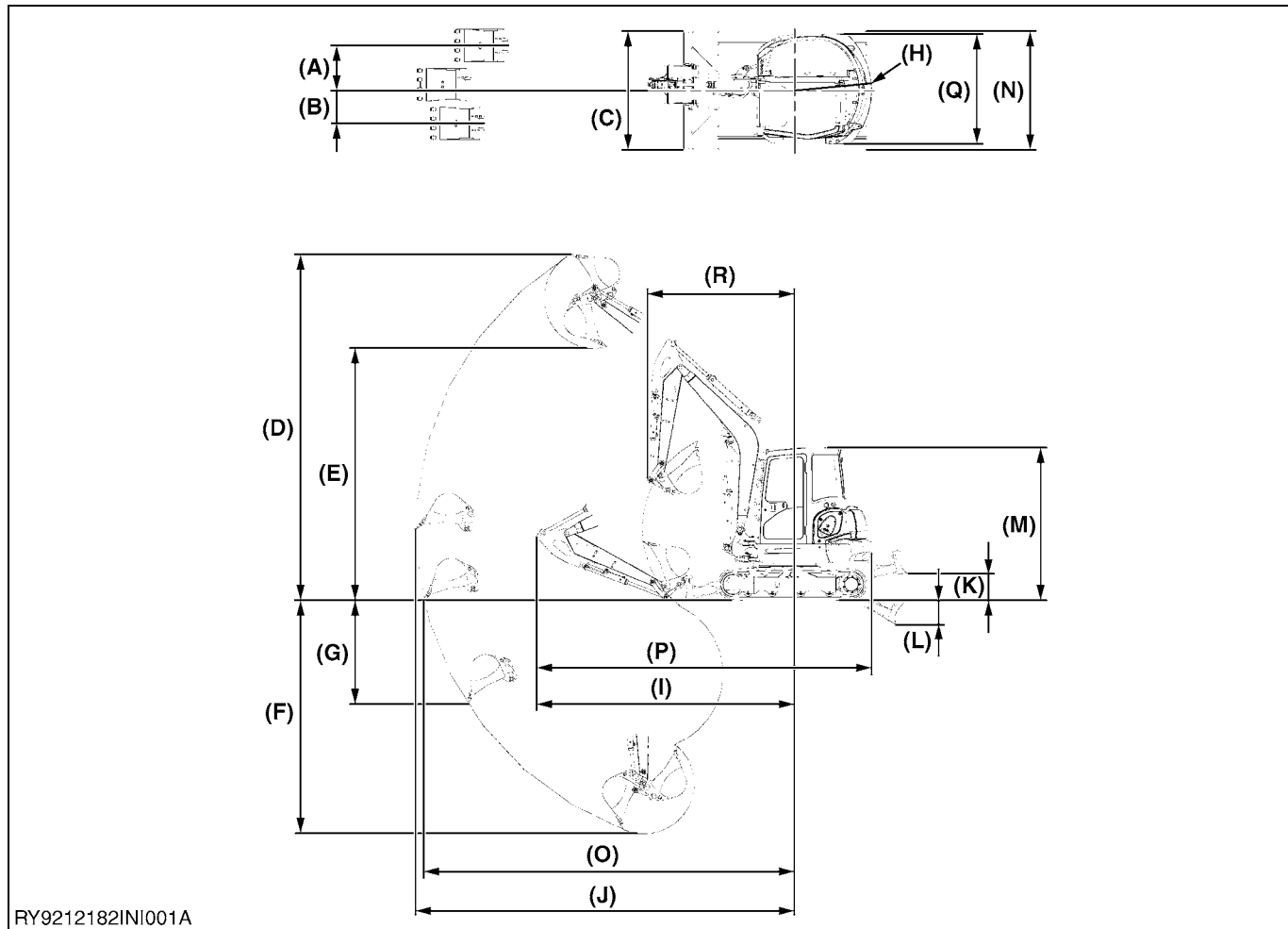

RY9212182INI001A

	(A)	(B)	(C)	(D)	(E)	(F)	(G)
KX040-4	575 mm 22.6 in.	400 mm 15.7 in.	1700 mm 66.9 in.	5335 mm 210 in.	3990 mm 157 in.	3420 mm 134.6 in.	2250 mm 88.6 in.
	(H)	(I)	(J)	(K)		(L)	
KX040-4	1300 mm 51.2 in.	3790 mm 149.2 in.	5540 mm 218.1 in.	400 mm 15.7 in.	ANG	405 mm 15.9 in.	ANG
					420 mm 16.5 in.		510 mm 20.1 in.
	(M)		(N)	(O)	(P)	(Q)	(R)
KX040-4	CANOPY	CAB	1700 mm 66.9 in.	5410 mm 213 in.	5070 mm 199.6 in.	1700 mm 66.9 in.	2180 mm 85.8 in.
	2485 mm 97.8 in.	2485 mm 97.8 in.					

■ **NOTE**

- Above dimensions are based on the machine with **QUICK HITCH BUCKET**.
- Above dimensions are based on the machine with rubber track.
- Specifications subject to change without notice.

RY9212174INI0008US0

G GENERAL

GENERAL

CONTENTS

1. CHECKING EXCAVATOR IDENTIFICATION	G-1
2. ENGINE IDENTIFICATION	G-2
[1] MODEL NAME AND SERIAL NUMBER	G-2
[2] E4B ENGINE	G-3
[3] CYLINDER NUMBER.....	G-4
3. MUFFLER FULL ASSEMBLY IDENTIFICATION	G-5
[1] PART NUMBER AND SERIAL NUMBER	G-5
4. GENERAL PRECAUTIONS.....	G-7
5. HANDLING PRECAUTIONS FOR ELECTRICAL PARTS AND WIRING	G-11
[1] WIRING	G-11
[2] FUSES.....	G-13
[3] CONNECTOR	G-13
[4] WASHING THE MACHINE WITH A HIGH-PRESSURE WASHER	G-15
6. TIGHTENING TORQUES.....	G-16
[1] TORQUES FOR GENERAL USE NUTS AND BOLTS	G-16
[2] TORQUE FOR HYDRAULIC HOSE FITTINGS	G-17
(1) Torque for Hydraulic Hose Fittings.....	G-17
(2) Torques of Lock-Nuts for Elbows with Male Seats and Adaptors with O-rings (Straight Threads).....	G-17
[3] HOSE CLAMP SCREW TORQUE	G-18
7. OIL AND WATER CAPACITY TABLE	G-20
8. MAINTENANCE INTERVALS.....	G-21

1. CHECKING EXCAVATOR IDENTIFICATION

When consulting with your local KUBOTA dealer about this mini-excavator, please provide the model of the mini-excavator, its frame and engine numbers and the number of hours on the hour meter.

- (1) Mini-excavator Nameplate
(Model, frame number, engine number)
- (2) Frame Number
- (3) Engine Number

(a) Model Nameplate

RY9212174GEG0001US0

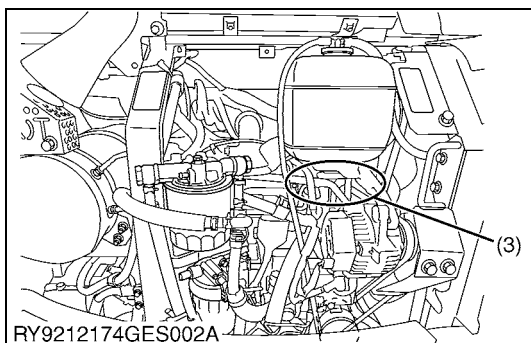
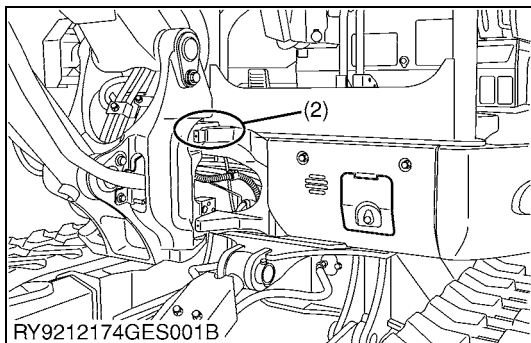
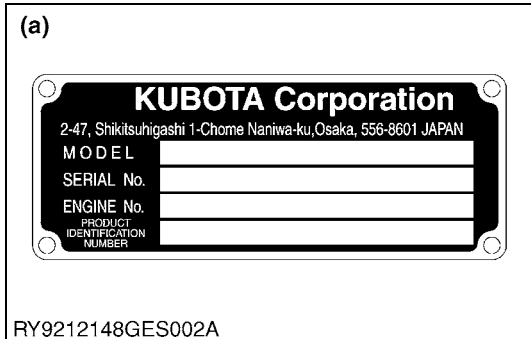
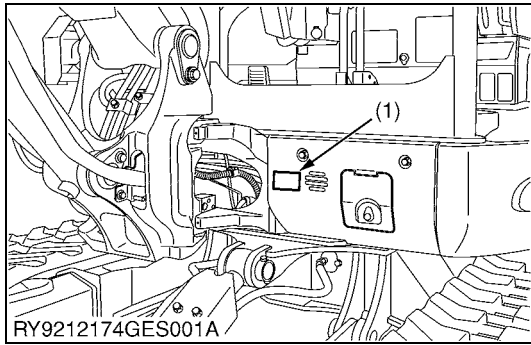

2. ENGINE IDENTIFICATION

[1] MODEL NAME AND SERIAL NUMBER

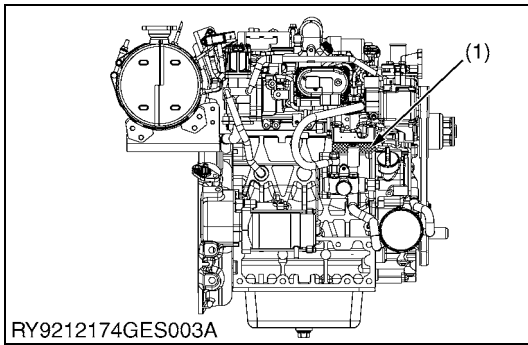

You must identify the engine model name and serial number before you start a job. When you get in touch with the manufacturer, always tell your engine model name and serial number.

Engine Serial Number

The engine serial number is an identified number for the engine. It appears after the engine model number. It shows the month and year of manufacture as below.

Engine Series

Number or Alphabet	Series	Number or Alphabet	Series
1	05 (include: WG)	6	GZ, OC, AC, EA, E
2	V3	7	03
3	08	8	07
4	SM (include: WG)	A	EA, RK
5	Air Cooled Gasoline	B	03 (KET Production)

Production Year

Alphabet or Number	Year	Alphabet or Number	Year
1	2001	F	2015
2	2002	G	2016
3	2003	H	2017
4	2004	J	2018
5	2005	K	2019
6	2006	L	2020
7	2007	M	2021
8	2008	N	2022
9	2009	P	2023
A	2010	R	2024
B	2011	S	2025
C	2012	T	2026
D	2013	V	2027
E	2014		

(1) Engine Model Name and Serial Number

(To be continued)

(Continued)

Production Month and Lot Number

Month	Engine Lot Number	
January	A0001 to A9999	from B0001
February	C0001 to C9999	from D0001
March	E0001 to E9999	from F0001
April	G0001 to G9999	from H0001
May	J0001 to J9999	from K0001
June	L0001 to L9999	from M0001
July	N0001 to N9999	from P0001
August	Q0001 to Q9999	from R0001
September	S0001 to S9999	from T0001
October	U0001 to U9999	from V0001
November	W0001 to W9999	from X0001
December	Y0001 to Y9999	from Z0001

* Alphabetical letters "I" and "O" are not used.

(a) (b)(c)(d) (e)
e.g. V2607 - 8 C L A001

- (a) **V2607**: Engine Model Name
- (b) **8**: Engine Series (07 series)
- (c) **C**: Production Year (2012)
- (d) **L**: Production Month (June)
- (e) **A001**: Lot Number: (**0001 to 9999** or **A001 to Z999**)

RY9212174GEG0002US0

[2] E4B ENGINE

[Example: Engine Model Name V3300-CR-**TE4(C)B**-XXXX or V3300-CR-**TIE4(C)B**-XXXX]

The emission controls previously implemented in various countries to prevent air pollution will be stepped up as Nonroad Emission Standards continue to change. The timing or applicable date of the specific Nonroad Emission regulations depends on the engine output classification.

Over the past several years, KUBOTA has been supplying diesel engines that comply with regulations in the respective countries affected by Nonroad Emission regulations. For KUBOTA Engines, E4B will be the designation that identifies engine models affected by the next emission phase (See the table below).

When servicing or repairing ###-E4B series engines, use only replacement parts for that specific E4B engine, designated by the appropriate KUBOTA Parts List and perform all maintenance services listed in the appropriate KUBOTA Operator's Manual or in the appropriate KUBOTA Workshop Manual. Use of incorrect replacement parts or replacement parts from other emission level engines (for example: E3B engines), may result in emission levels out of compliance with the original E4B design and EPA or other applicable regulations. Please refer to the emission label located on the engine head cover to identify Output classification and Emission Control Information. E4B engines are identified with "EF" at the end of the Model designation, on the US EPA label. Please note: E4B is not marked on the engine.

Category (1)	Engine output classification	EPA regulation
EF	Less than 19 kW	Tier 4
	From 19 to less than 56 kW	Interim Tier 4
	From 56 to less than 75 kW	Interim Tier 4
	From 75 to less than 130 kW	Interim Tier 4

NOTE

- "E4B" engines are identified with "EF" at the end of the Model designation, on the US EPA label. "E4B" designates some Interim Tier 4 / Tier 4 models, depending on engine output classification.

RY9212174GEG0008US0

(1)

EMISSION CONTROL INFORMATION		
THIS ENGINE MEETS 2012 ##### EMISSION REGULATIONS FOR U.S. EPA AND CALIFORNIA NONROAD ENGINES.		
Kubota KUBOTA Corporation		
MODEL: ###-EF-###	ENGINE DISP.: ###	
FAMILY: G###		
POWER: ## kW / ### rpm	CATEGORY: ##-## kW	
VALVE CLEARANCE (COLD):	IN ## mm EX ## mm	
ECS: ### ###		
ULTRA LOW SULFUR DIESEL FUEL ONLY		
DEL. ASSY:	####	

RY9212134GES005A

[3] CYLINDER NUMBER

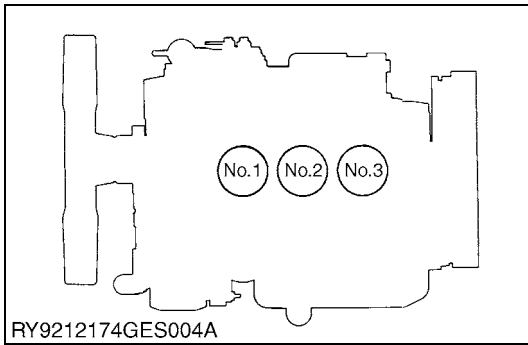

You can see the cylinder numbers of KUBOTA diesel engine in the figure.

The sequence of cylinder numbers is No.1, No.2 and No.3 and it starts from the gear case side.

RY9212174GEG0003US0

3. MUFFLER FULL ASSEMBLY IDENTIFICATION

[1] PART NUMBER AND SERIAL NUMBER

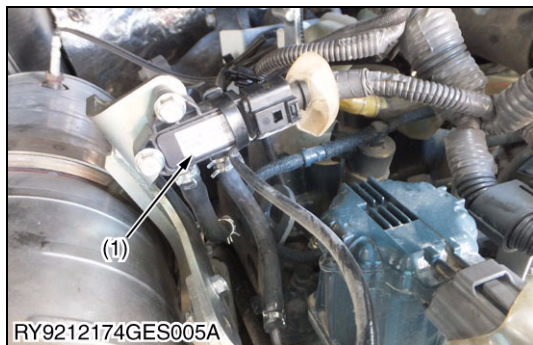

Diesel Particulate Filter (hereinafter referred to as the "DPF") Muffler Full Assembly Serial Number

The DPF muffler full assembly serial number is an identified number for the DPF muffler full assembly.

It shows the month and year of manufacture as below.

Year of manufacture

Alphabet or Number	Year	Alphabet or Number	Year
1	2001	F	2015
2	2002	G	2016
3	2003	H	2017
4	2004	J	2018
5	2005	K	2019
6	2006	L	2020
7	2007	M	2021
8	2008	N	2022
9	2009	P	2023
A	2010	R	2024
B	2011	S	2025
C	2012	T	2026
D	2013	V	2027
E	2014		

Month of manufacture

Month	DPF Muffler Full Assembly Lot Number	
January	A0001 to A9999	B0001 to BZ999
February	C0001 to C9999	D0001 to DZ999
March	E0001 to E9999	F0001 to FZ999
April	G0001 to G9999	H0001 to HZ999
May	J0001 to J9999	K0001 to KZ999
June	L0001 to L9999	M0001 to MZ999
July	N0001 to N9999	P0001 to PZ999
August	Q0001 to Q9999	R0001 to RZ999
September	S0001 to S9999	T0001 to TZ999
October	U0001 to U9999	V0001 to VZ999
November	W0001 to W9999	X0001 to XZ999
December	Y0001 to Y9999	Z0001 to ZZ999

* Alphabetical letters "I" and "O" are not used.

(a)(b) (c)
e.g. C L 0019

(1) DPF Muffler Full Assembly Part Number and Serial Number

(a) Year: C indicates 2012

(b) Month: L or M indicates June

(c) Lot Number: (0001 to 9999 or A001 to Z999)

RY9212174GEG0004US0

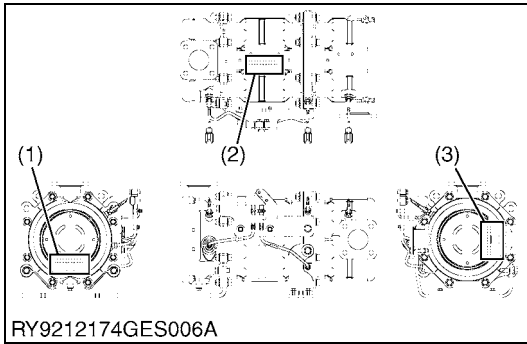

You must keep the records of the filter comp (DPF) part number and serial number before you remove the DPF for cleaning.

- (1) Body (DPF Outlet) Part Number and Serial Number
- (2) Filter Comp (DPF) Part Number and Serial Number
- (3) Catalyst (DOC) Part Number and Serial Number

RY9212174GEG0005US0

4. GENERAL PRECAUTIONS

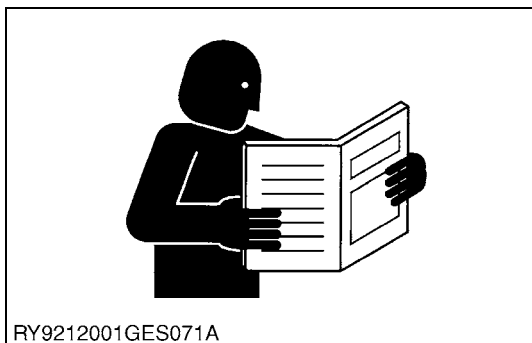

Whenever performing maintenance on the machine, always read the Safety Precautions in this manual and the Operator's Manual carefully, become familiar with them and perform the work safely.

Before performing any maintenance on the machine, make sure it is sufficiently clean and choose a sufficiently clean location to perform any disassembly.

Before performing maintenance on the machine, always disconnect the negative battery cable first.

Whenever a special tool is required, use the special tool that KUBOTA recommends. Make any special tools that are not used very frequently according to the diagrams in this manual.

Always use genuine KUBOTA parts to maintain the performance and safety characteristics of the machine.

RY9212001GEG0011US0

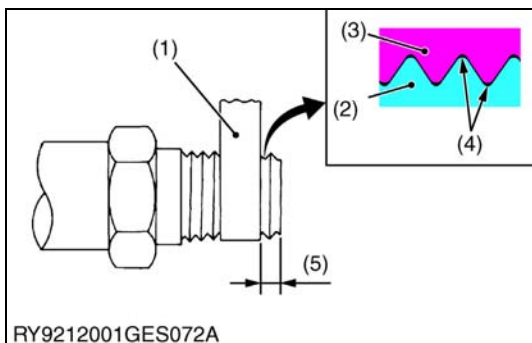

Plumber's Tape

- Wrap plumber's tape on the threads before tightening taper couplings. After wrapping (2 wraps) the plumber's tape, tighten to the specified torque. Once the coupling is tightened, do not loosen it as this will cause an oil leak.

- | | |
|---------------------|--------------------------|
| (1) Plumber's Tape | (4) Gap |
| (2) External Thread | (5) Leave 1 to 2 Threads |
| (3) Internal Thread | |

RY9212001GEG0012US0

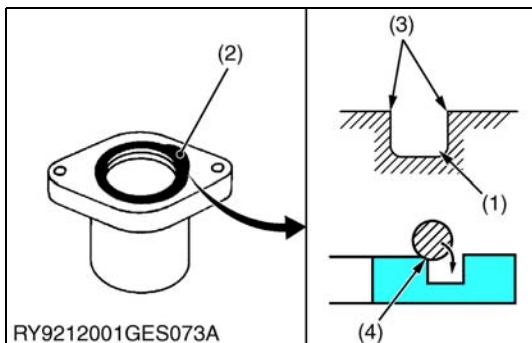

O-Ring

- Clean the groove the O-ring goes in and remove any burrs. Apply grease on the O-ring when inserting it in the groove. (Except floating seals)
- When putting the O-ring in the groove, be careful as it is easy at the very end to twist the O-ring against the inside of the groove. If it gets twisted, roll it gently with your fingertip to untwist it.

- | | |
|---------------------|--|
| (1) O-Ring Groove | (4) If the Ring Touches This Corner, It Will Twist |
| (2) O-Ring | |
| (3) Check for Burrs | |

RY9212001GEG0013US0

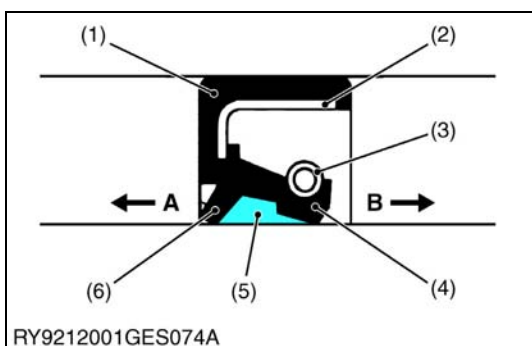

Oil Seal

- Do not face the lip of the oil seal in the wrong direction. Face the main lip toward the material to be sealed.
- After oil seals are replaced, apply grease to the moving parts around the lip to prevent the dry surfaces from wearing against each other when the engine is started. If the seal has a dust lip, fill the gap between the lips with grease.
- As a general rule, use a press to insert the oil seal in place. If that is not possible, use an appropriate tool to gently and evenly tap it into place, taking care that it does not go in at a slant. Press the seal all the way so it seats in the boss.

- | | |
|----------------|---------------------------------------|
| (1) Gasket | A : Air (Outside) |
| (2) Metal Ring | B : Hydraulic Chamber (Inside) |
| (3) Spring | |
| (4) Main Lip | |
| (5) Grease | |
| (6) Dust Lip | |

RY9212001GEG0014US0

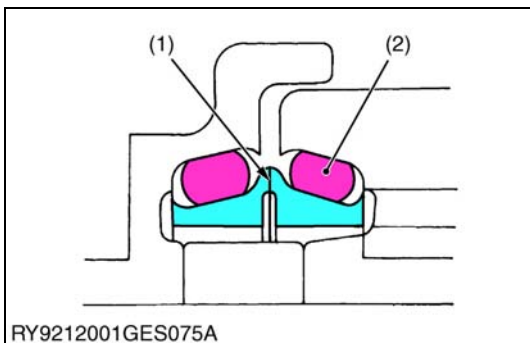

RY9212001GES075A

Floating Seal

- Be sure to wipe off any oil from the O-ring or surfaces that touch the O-ring. (For wheel motors, apply a light film)
- When putting an O-ring into a floating seal, make sure the O-ring does not twist.
- Apply a light film of oil to surrounding surfaces when working to get the floating seal with O-ring in place; take care that the surrounding surfaces, O-ring and housing are parallel with each other.
- After getting the seal in place, turn the engine over 2 or 3 revolutions, to both create a film of oil on surrounding surfaces and to properly seat the face of the seal.

(1) Surrounding Surfaces (2) O-Ring

RY9212001GEG0015US0

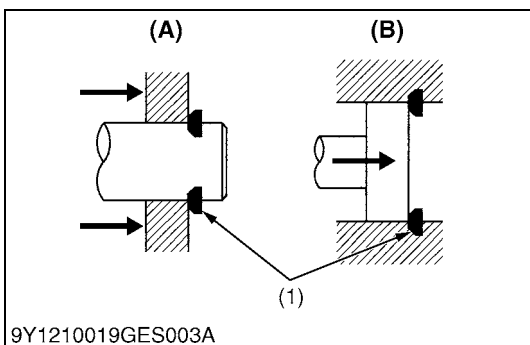

9Y1210019GES003A

Snap Ring Related

- When installing external or internal snap rings, orient them as shown in the diagram so the angled side faces the direction of force.

(1) Position so the Angled Part Receives the Force (A) External (B) Internal

RY9212001GEG0016US0

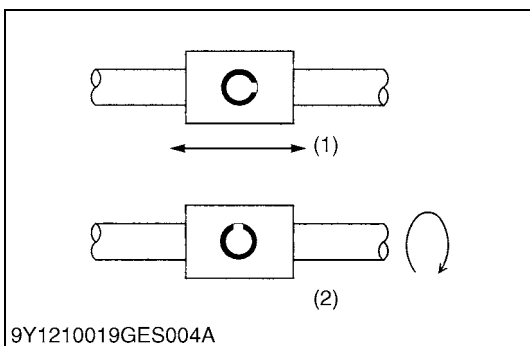

9Y1210019GES004A

Spring Pins

- When driving a spring pin, face the split in the direction that receives the force, as shown in the diagram.

(1) With Lateral Movement (2) With Rotational Movement

RY9212001GEG0017US0

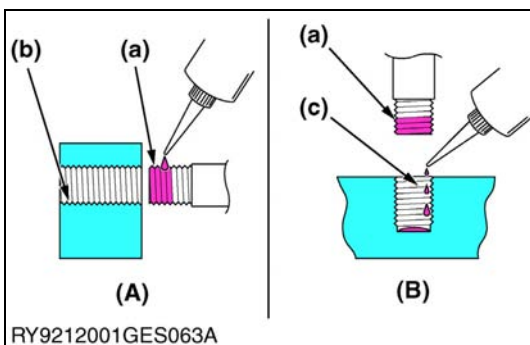

RY9212001GES063A

Adhesive

- Clean and dry the area where adhesive will be applied with a solvent so it is free of moisture, oil and dirt.
- Apply adhesive all around the threads of the bolt except the first set of threads at the tip and fill the grooves between the threads. If the threads or the grooves are large, adjust the amount of adhesive accordingly and apply it all around the bolt hole as well.

(A) Bolt Through-Hole (Nut) (a) Apply Here (b) Do Not Apply (c) Drip On
 (B) Pocket Bolt Hold (a) Apply Here (b) Do Not Apply (c) Drip On

RY9212001GEG0018US0

Product: 2013 Kubota WSM KX040-4 Excavator Service Repair Workshop Manual

Full Download: <https://www.arespairmanual.com/downloads/2013-kubota-wsm-kx040-4-excavator-service-repair-workshop-manual/>

0-4-excavator-service-repair-workshop-manual/

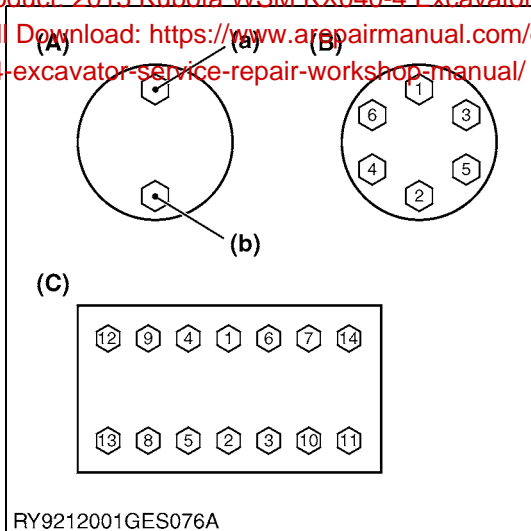

RY9212001GES076A

Tightening Bolts and Nuts

- Tighten bolts and nuts to their specified torque.
- Tighten nuts and bolts alternately top/bottom **(a) (b)**, left/right so the torque is distributed evenly.

(A) Top/Bottom Alternately
(B) Across Diagonally

(C) Diagonally Across the Center

RY9212001GEG0019US0

Assembling Hydraulic Hoses

- Tighten to their specified torque.
- Before assembling, wipe the inside of metal fittings clean of any dirt.
- After assembly, put the fitting under normal pressure and check that it does not leak.

RY9212001GEG0020US0

Elbow with Male Seat Assembly Procedure

When assembling an elbow with male seat, adhere to the following procedures to prevent deformation of O-rings and leaks.

1. Connecting to Valves
 - Clean the blow with male seat and the surface of the seal opposite and mount with the lock-nut on top.
 - Finger tighten till it touches the washer.
2. Positioning
 - Turn the mouth of the elbow back so it faces the right direction. (not back over 1 turn)

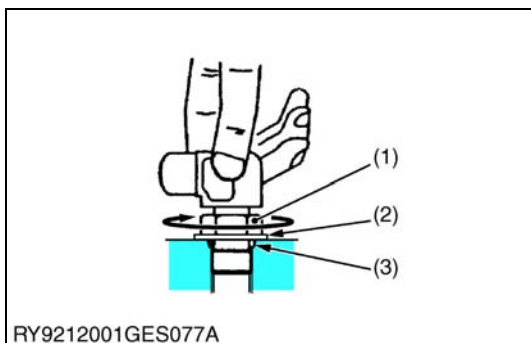

RY9212001GES077A

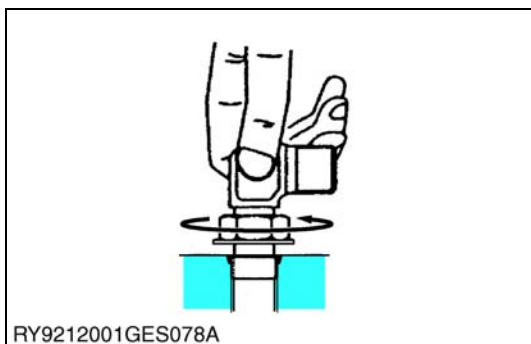

RY9212001GES078A

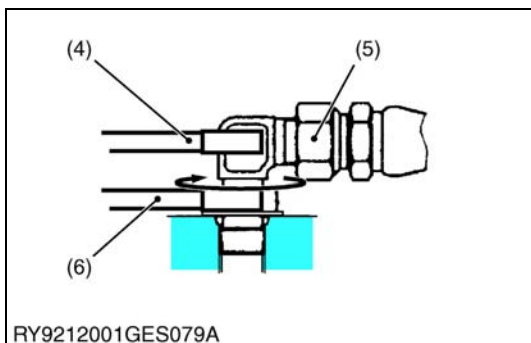

RY9212001GES079A

3. Fasten
 - Tighten the lock-nut to the specified torque with a wrench.

- | | |
|-------------------|----------------------------------|
| (1) Lock-Nut | (4) Wrench for Holding |
| (2) Washer | (5) Hose |
| (3) Seal (O-Ring) | (6) Torque Wrench for Tightening |

RY9212001GEG0021US0

Sample of manual. Download All 450 pages at: <https://www.arespairmanual.com/downloads/2013-kubota-wsm-kx040-4-excavator-service-repair-workshop-manual/>