

Product: Kubota WSM U20-3,U25-3,U25S- Excavator Service Repair Workshop Manual(Service Chapter)  
Full Download: <https://www.arepairmanual.com/downloads/kubota-wsm-u20-3u25-3%ce%b1u25s%ce%b1-excavator-service-repair-workshop-manual-service-chapter/>

# WSM

## WORKSHOP MANUAL KUBOTA EXCAVATOR

### U25S U20-3 $\alpha$ U25-3 $\alpha$ Service Chapter

The Kubota logo is displayed in a bold, black, stylized font. The letters are thick and blocky, with a distinctive shape for the 'K' and 'O's.





Sample of manual. Download All 478 pages at:

<https://www.arepairmanual.com/downloads/kubota-wsm-u20-3u25-3%ce%b1u25s%ce%b1-excavator-service-repair-workshop>

Code No.97899-61500

Record of Revisions

Full Download: [https://www.arepairmanual.com/downloads/kubota-wsm-u20-3u25-](https://www.arepairmanual.com/downloads/kubota-wsm-u20-3u25-3%ce%b1u25s%ce%b1-excavator-service-repair-workshop-manual-service-chapter/)

Symbol	Date	Main Revised Points & Corrective Measures	Person-in-charge
			
			
			
			

# CONTENTS

## I General

## II Machine body

## III Engine

- 05-M Series Engine.....III-S-1
- Mechanism Section..... III-M-25
- Service Section .....III-S-47

## IV Hydraulic System

## V Electrical System

**(Note)**

**U25S is for KTC, KCL and KTA, what we call, PP-version in this manual.**

**U20-3 $\alpha$  and U25-3 $\alpha$  are for KE, KUK and KBM, what we call, EU-version in this manual.**



# I General

- A. Body and engine identification marks . . . . . I-S-3
- B. Safety precautions for servicing, disassemble and reassembly . I-S-4
- C. Important safety process and critical functional process . I-S-6
- D. Important inspection items after reassembling. . . . . I-S-6
- E. Servicing fundamentals . . . . . I-S-7
- F. Maintenance intervals . . . . . I-S-16

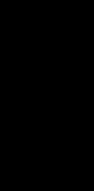

# A. Body and engine identification marks

If trouble should occur during use, or if servicing is necessary, contact the dealer who handles the machine. At that time please inform the machine model and engine type and serial numbers.

## (1) Machine serial number

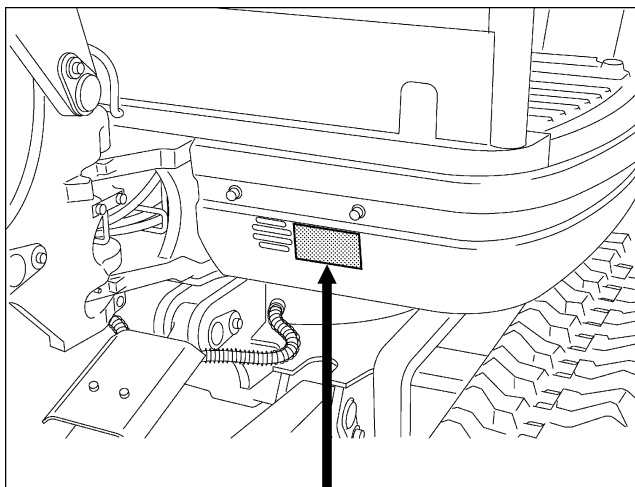

<b>KUBOTA Corporation</b> 2-47, Shikitsuhigashi 1-Chome, Naniwa-ku, Osaka, 556-8601 JAPAN			
MODEL	<input type="text"/>		SERIAL NO.
MASS	<input type="text"/> kg	MAX. DRAW BAR PULL	<input type="text"/> kN
POWER	<input type="text"/> kW	MAX. VERT. LOAD	<input type="text"/> kN
PRODUCT IDENTIFICATION NUMBER	<input type="text"/>		
MANUFACTURED YEAR	<input type="text"/>	MADE IN JAPAN.	

1BAABAAP288A

KTC, KCL, KTA-version

<b>KUBOTA Corporation</b> 2-47, Shikitsuhigashi 1-Chome, Naniwa-ku, Osaka, 556-8601 JAPAN	
MODEL	<input type="text"/> ①
SERIAL No.	<input type="text"/> ②
ENGINE No.	<input type="text"/> ③
PRODUCT IDENTIFICATION NUMBER	<input type="text"/> ④

Name plate : Code No. RA018-57721

## (2) Engine serial number

e.g. D1105-5L0025

“5” indicates year of 2005 and “L” indicates June. So, 5L indicates that the engine was manufactured in June 2005.

## (3) Engine serial number

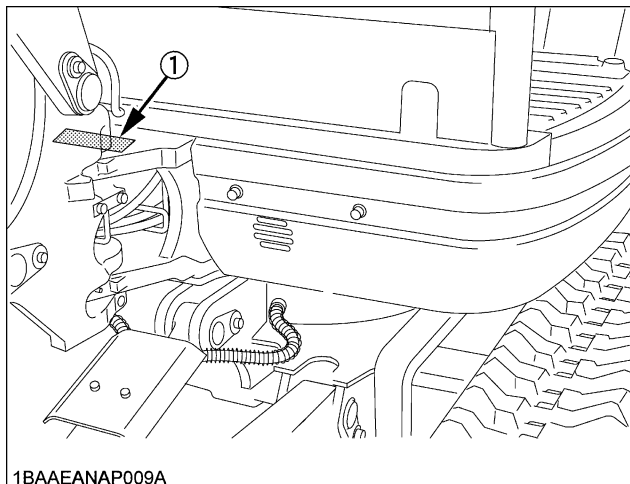

1BAAEANAP009A

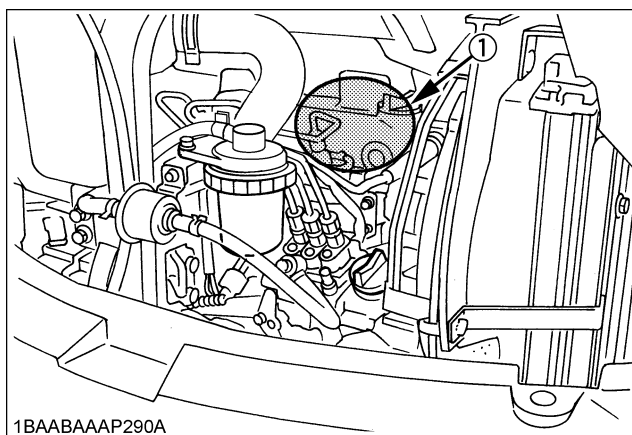

1BAABAAP290A

## (Engine production month code)

Month	Serial No.	
	0001~9999	10001~19999
Jan.	A	B
Feb.	C	D
Mar.	E	F
April	G	H
May	J	K
June	L	M
July	N	P
Aug.	Q	R
Sept.	S	T
Oct.	U	V
Nov.	W	X
Dec.	Y	Z

## B. Safety precautions for servicing, disassembly and reassembly

### Safety precautions for servicing

Most accidents during servicing arise from carelessness. Please remember that Safety involves both the welfare of the employees and improved work efficiency.

### Safety precautions for Disassembly and reassembly

Machines must be disassembled and assembled efficiently and safely.

It is very important to thoroughly understand the construction and function of the machine, to make all appropriate preparations, and start operations according to the specified working procedures.

#### a. Safety measures before starting work

##### (1) Work clothes

1. Wear specified work cap and clothed. (Under no circumstances may workers wear undershirts only.)  
Cuffs must be kept buttoned, and any tears must be mended.)
2. Wear safety shoes.
3. Do not wear cotton gloves when working on the internal section of engine, reduction gears or hydraulic units for repair or others, or when using a hammer. Wear leather gloves, however, when hoisting wires.

##### (2) Inspecting equipment and tools

1. Prepare equipment (cranes, fork lifts, tool, etc.) required for servicing and inspect for any problems before starting work.
2. Hammer heads (metal parts) must be firmly secured to their handles.
3. Check hoisting tools (wire ropes, hoisting chains, etc.) before use.

##### (3) Keep workshop in order

1. Secure appropriate space needed for disassembly to the job.
2. Secure a clean, safe place for arranging disassembled parts.
3. Store volatile substances (gasoline, light oil, thinner, oily articles, etc.) in appropriate containers at selected locations to prevent fire hazards.

#### b. Safety measures during work

##### (1) Protectors

1. Wear goggles when using chisels for chipping.
2. Use appropriate protectors during welding.
3. Wear a helmet when working with a crane or at elevated locations.

##### (2) Team work

1. When working with two or more people, divide the work and maintain close communication.
2. Crane work must be carried out using predetermined signals.

##### (3) Disassembly and assembly

1. Do not wear gloves when using hammers.
2. Use rods of the specified soft material for removing pins. Do not use a hammer as a pad.
3. Do not place fingers in holes when centering.
4. Heavy parts must be adequately supported before removing bolts.

##### (4) Cranes

1. In principle, use a crane for objects heavier than 44lb (20kg).
2. Crane operation and hoisting must be performed only by qualified personal.
3. Pay careful attention to the center of gravity when hoisting, and do not stand under the lifted objects.

##### (5) Others

1. To work under a jacked-up carrier, be sure to place wood pieces under it.
2. When charging batteries, make sure there are no open flames in the immediate vicinity.
3. All electric tools must be grounded.
4. Before welding the machine, remove the battery.
  - When removing the battery, be sure to disconnect negative (-) cord first.
  - When mounting the battery, be sure to connect the positive (+) cord first.

## c. Preparation for disassembly

### (1) Cleaning

Remove mud and dirt from the body before disassembly.

### (2) Acceptance inspection

The machine must be checked before it is disassembled to record existing conditions, such as those listed below.

Model, serial number, and hourmeter reading

- Reason for repair and repair history
- Element stains
- Fuel and oil condition
- Parts damage \*(Take photographs if necessary.)

### (3) Equipment and tools

prepare equipment, tools, cranes and parts storage racks as required.

## d. Precautions for disassembly and reassembly

### (1) Disassembly

1. Follow the specified disassembly procedures.
2. Make alignment marks to insure correct reassembly.
3. Arrange disassembled parts in an orderly way, and attach identification tags or put marks if needed.

### (2) Reassembly

1. Clean all parts before assembly. Repair any scratches or dents. Take special precautions against dirt and dust.
2. Parts with rust-preventive coatings must be assembled only after removing the coating.
3. Separated parts must be correctly reassembled using alignment marks.
4. As a rule, use a press to reassemble bearings, bushing and oil seals. Use pads when using a hammer.

## C.IMPORTANT SAFETY PROCESS AND CRITICAL FUNCTIONAL PROCESS

The following instructions are related to essential adhesives, important safety process **[S]** and critical functional process **[A]**. Pay special attention in servicing these process. (Pay also close attention in reconnecting the electrical cables.)

### a. Essential Adhesives

Type of screw adhesive

- Unless otherwise specified, use Three-Bond 1324 adhesive (medium-duty type).  
Keep the screw threads free of oil and water.

Type of instantaneous adhesive

- Use Three-Bond 1733 or Three-Bond 1741E adhesive.  
Keep the bond areas free of oil and water.

### b. Important Safety Process **[S]**.

1. Reconnecting the fuel hose (clearance, hose routes, clamps, etc.)
2. Electrical cabling (engine, instrument panel, seat stand, etc.) (wiring routes, clamps and couplers)

### c. Important Critical Functional Process **[A]**.

1. Setting up the travel wheel motor (tightening torque)
2. Reassembling the rotary joints (joint direction and shaft set-up)
3. Installing the swivel base bearing and the swivel motor (tightening torque)
4. Fitting the pump couplings (tightening torque)

## D.IMPORTANT INSPECTION ITEMS AFTER REASSEMBLING

- a Operate the Machine and check for Unusual Noise and Vibrations.
- b Make Sure the Safety decals and Wireharness Clamps are in their Specified Positions.
- c With the Machine Front in a Specified Posture, Check the Amount of Hydraulic Oil

Checking the oil level (For further details, refer to the Operator's Manual of each model.)

- (1) Park the machine on a level ground.
- (2) Make sure the hydraulic oil temperature is in the range of 10-30°C (50-86°F) and see if the oil level is within the specified zone of the oil level gauge.
- (3) Keep the machine front as shown as following posture.

Posture: Extend the rods of the arm and bucket cylinders nearly half. Place the bucket on the ground, the offset swing at the center, and the dozer also on the ground.

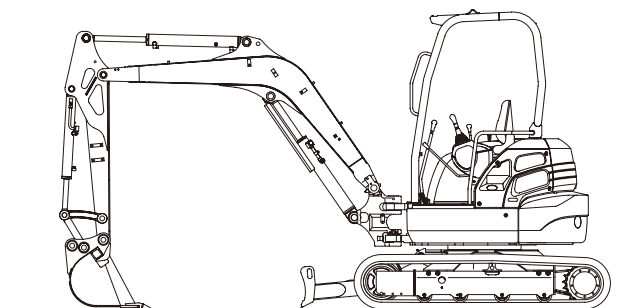

# E.SERVICING FUNDAMENTALS

Locking adhesive

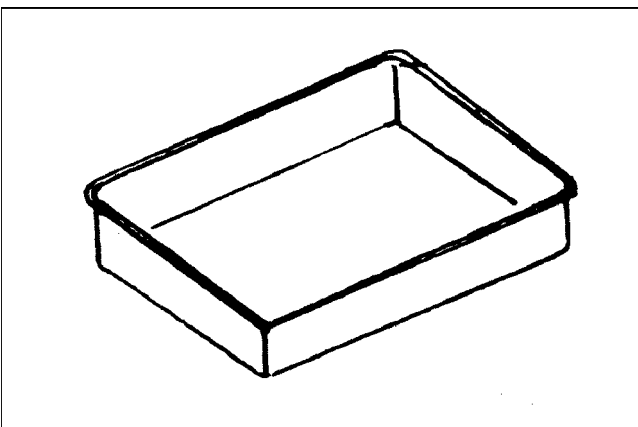
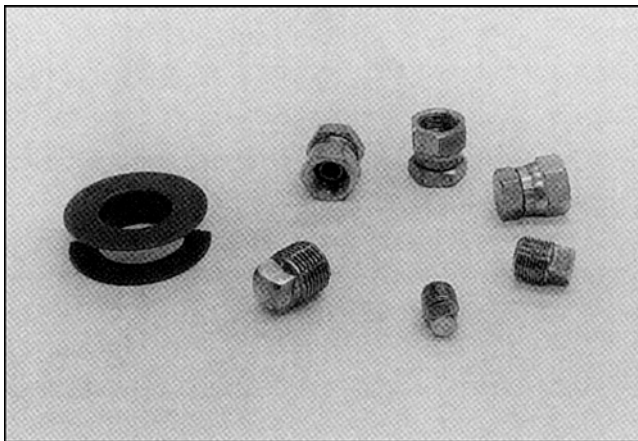
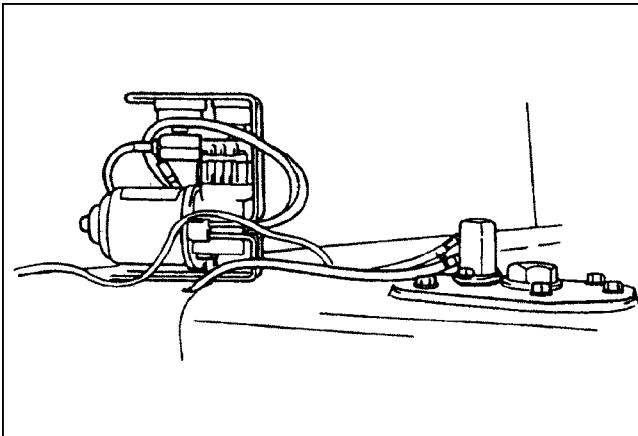

## a. Items for Servicing

- (1) Tighten bolts, nuts, adapters, and similar parts to their specified torques which are given in the list of tightening torques and adhesive as well as in this manual. Be sure to observe the specified torques for important tightened parts and components.
- (2) Wipe out water, oil and grease off the screws on which LOCTITE adhesive is to be applied. Be sure to apply the adhesive to specified locations.

Types of screw adhesive
Equivalent to LOCTITE 271 (Heavy-duty)
Equivalent to THREE-BOND 1305P (Heavy-duty)
Equivalent to THREE-BOND TB1401B (Light-duty)
Unless specified otherwise, use THREE-BOND 1324 (Medium-duty).

Type of instantaneous adhesive
Use THREE-BOND 1733 or 1741E

The word "LOCTITE" in this manual denotes the red-color type.

- (3) Precautions in disassembling the hydraulic equipment
  - Use a vacuum pump, plugs, oil pans, waste cloth and the like to prevent oil from running out or splashing. Wipe out leaking oil completely first and then add oil as required.
  - Protect the openings with plugs, covers or the like to keep off foreign matters. Most of hydraulic system troubles are caused by the entry of foreign matters.
  - Before reassembling, clean up the parts and components and apply hydraulic oil on them.
  - The system consists of precision parts. Be careful not to scratch them and apply excessive force on them.

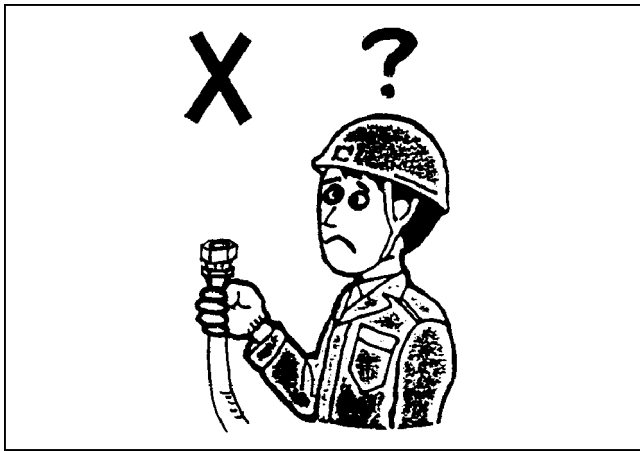

- (4) Precautions in tightening hoses and pipes.
- Flexible hoses have a slight natural bend of their own. Utilize the natural bend. Be also careful not to twist them.
  - Be careful not to confuse the routes of the hoses.
  - Do not hold the hoses in tight contact with their adjacent parts and surfaces.

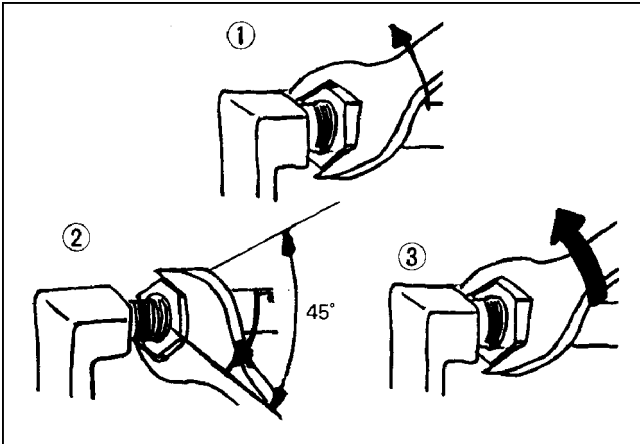

- Tightening steps
  1. First tighten the nut to its specified torque.
  2. Then loosen the nut by about 45° to fit the seat of the joint to the connection.

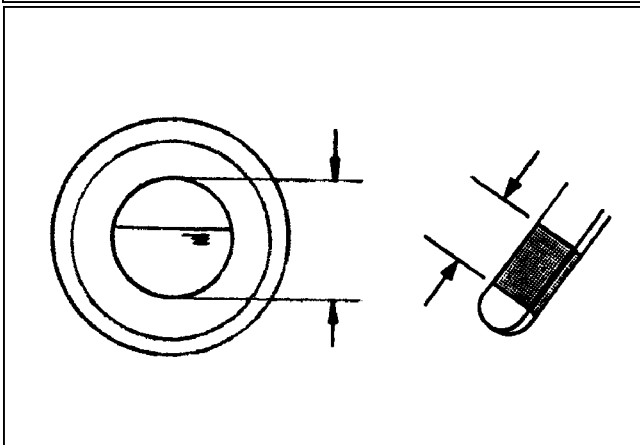

- (5) The quantities of oil, fuel, water and others, except for the oil to be filled in the track rollers and idlers, are listed just as reference. Fill up the fluid up to the specified center level of a level gauge if it is provided.

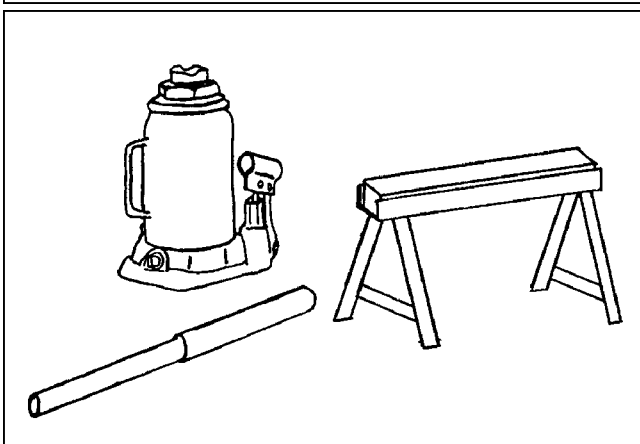

- (6) Security support the machine with a jack and a supporting jig when it is jacked up for servicing.
- (7) Be sure to use a crane in disassembling and reassembling heavy parts and components (frame, front attachment, crawler, etc.).

## b. O-ring, Oil seal, Circlip and Roll Pin

### (1) General precautions

- Make sure the O-ring and the oil seal are free of anything unusual (uneven surface, scratches, chipping, etc.).
- Check the O-ring groove for burrs. Correct, if any, using an oil stone or the like.
- When putting a part past a sharp edge into position, protect such edge with a cover or get the part chamfered.

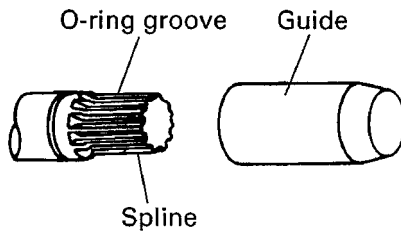

### (2) O-ring

- Clean up the O-ring groove and deburr its edge as required.
- Before installing the ring, be sure to apply lubricant (grease) over it. (Do not do this to the floating seal.)
- Fit the O-ring into its groove without twist. With your fingertip, push the ring gently and evenly into the final position. Otherwise the ring would easily get twisted in contact with the inner edge of the groove.

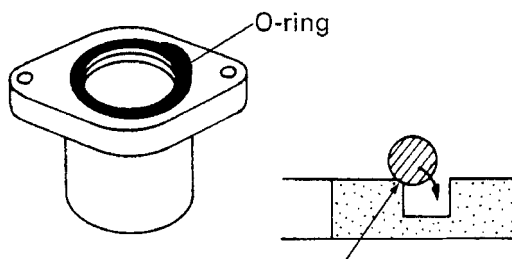
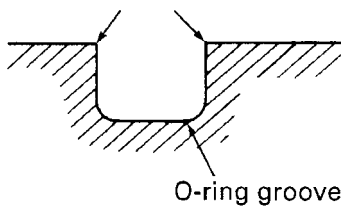

### (3) Floating seal

- Be sure to wipe oil off the O-ring and the O-ring contact surface. (Note, however, that oil must be applied thinly over those of the wheel motor.)
- In fitting the O-ring into the floating seal, be careful not to twist the O-ring.
- Before installing the floating seal together with the O-ring, apply sealing oil thinly over the sliding surface. Be careful to keep the sliding surface and O-ring in alignment with the housing.
- Finally turn the floating seal 2 or 3 times by hand in order to form an oil film over the sliding surface as well as to get the sealing surface well it.

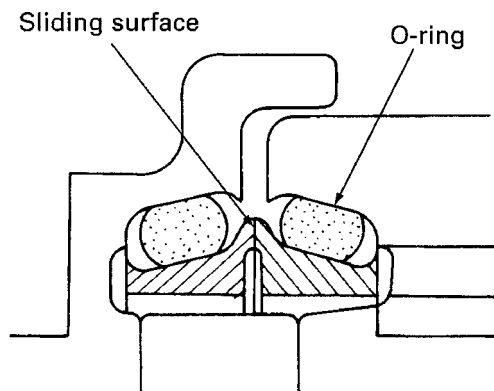

(4) Oil seal

- Do not confuse the orientation of the oil seal lips. Direct the main lip toward the oil chamber; in other word, toward what is to be sealed.

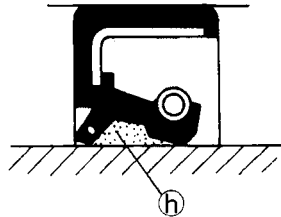
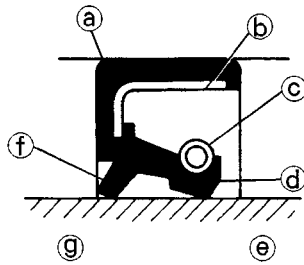

- |                         |                         |
|-------------------------|-------------------------|
| a. Packing              | f. Dustpans lip         |
| b. Metal ring           | g. Atmosphere (outside) |
| c. Spring               | h. Grease               |
| d. Main lip             |                         |
| e. Oil chamber (inside) |                         |

- If in dry state, the oil seal may wear out when running in the machine. To prevent this, be sure to apply lubricant (grease) over the lip sliding surface. If provided also with a dustproof lip, fill the space between this lip and the main lip with grease.
- As a rule, use a press to press-fit the oil seal. If not available, apply a suitable tool and tap it evenly without allowing any tilt. Press-fit the oil seal deep down to the bottom of the oil seal fitting boss.

(5) Mounting the circlip

- Place the circlip with its sharp edge facing outward (in the locking direction).
- Fit the circlip securely in the groove. For the hole circlip in particular, install and turn it slightly to make sure it fits well.

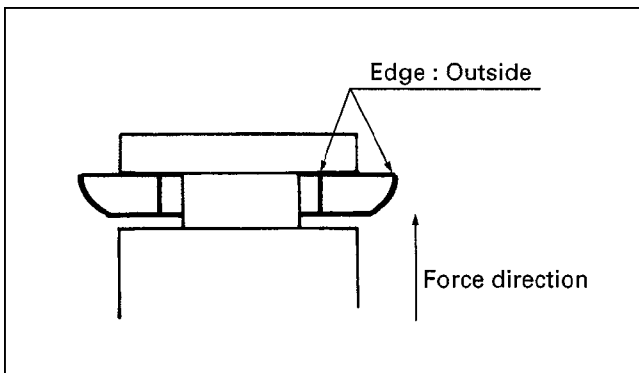

(6) Tapping the roll pin (spring pin)

- Place the roll pin (spring pin) with its opening perpendicular to the load.
- Place the roll pin (spring pin) with its opening in the turning direction.
- Evenly tap the roll pin (spring pin) into position.

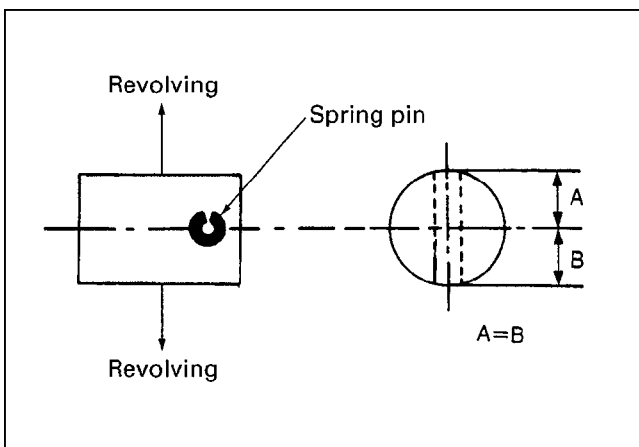

### c. Piping

#### (1) General precautions

- Tightening the pipe socket to the specified torque. If too tight, the socket itself or a hydraulic component may get damaged. If too loose, an oil leak may result.
- In connecting a new hose or pipe, tighten its nut first to the specified torque and then turn it back (about 45°). Then tighten it again to the specified torque. (Do not do this to the sealing tape-applied hose or pipe.)
- When disconnecting a vertical hose or pipe, separate its bottom connection first.
- In disconnecting and reconnecting the hose and pipe, be sure to use two wrenches. With one wrench, restrain the mating part to allow no twist.
- Check the mating connector's sleeve and the hose's taper for dust deposits and scratches.
- When the pipe socket has been tightened up, wipe the joint clean. Apply the maximum operating pressure 2 or 3 times to make sure there is no oil leak.

#### (2) Hydraulic hose

Check the hydraulic hose for too tight a contact or twist.

\*Excessively tight contact

Let's suppose that a hose is in contact with another hose or other part. If the hose is pulled away by a force of 2 kg but still in contact, it means the contact is too tight.

#### (3) Precautions in tightening the bolts and nuts

- Use bolts of specified length.
- Do not over tighten the bolts: Its threads may get deformed or the fixed part may get damaged. Do not undertighten the bolt either: It may get loose.
- In other words, tighten the bolt to the specified torque.
- Tighten the bolts and nuts diagonally for even tightness.

Top and bottom alternately

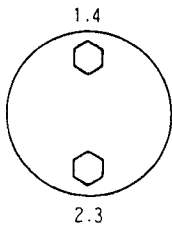

Diagonally

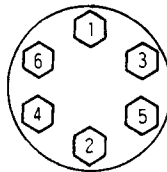

Diagonally starting from center

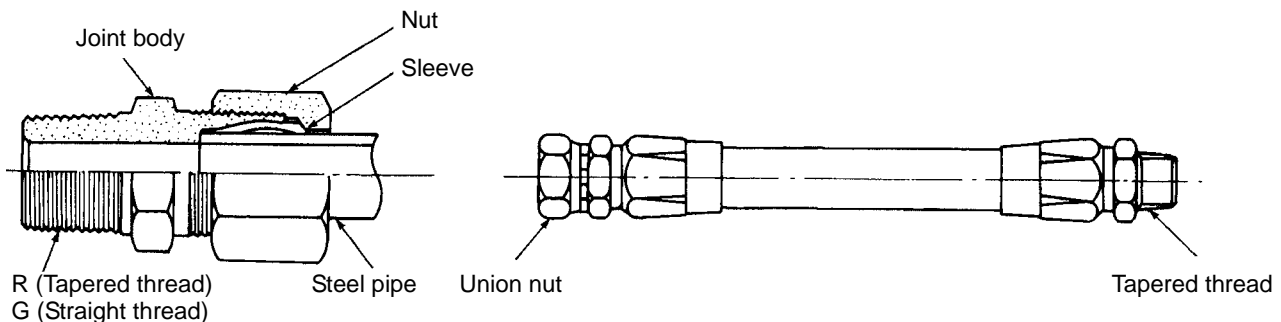
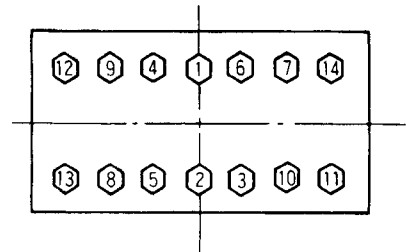

## (4) Hose screw

## Metric Size Hose

Thread size (piping screw)	Tightening torque N·m kgf·m ft·lbf		Wrench size (reference)	Thread size (piping screw)	Torque N·m kgf·m ft·lbf
	Union nut section	Taper thread section			
1/8"	7.8 ~ 11.8 N·m 0.8 ~ 1.2 kgf·m 5.8 ~ 8.7 ft·lbf	14.71 ~ 19.61 N·m 1.5 ~ 20 kgf·m 10.85 ~ 14.47 ft·lbf	17 mm 0.67 in	M12 × 1.5	20 ~ 30 2.0 ~ 3.1 14.75 ~ 22.13
1/4"	24.5 ~ 29.4 2.5 ~ 3.0 18.1 ~ 21.7	36.3 ~ 44.1 3.7 ~ 4.5 26.8 ~ 32.5	19 mm 0.75 in	M14 × 1.5	20 ~ 30 2.0 ~ 3.1 14.75 ~ 22.13
3/8"	49.0 ~ 53.9 5.0 ~ 5.5 36.2 ~ 39.8	49.0 ~ 68.6 5.0 ~ 7.0 36.2 ~ 50.6	22 mm 0.87 in	M16 × 1.5	30 ~ 50 3.1 ~ 5.1 22.13 ~ 36.9
1/2"	58.8 ~ 63.7 6.0 ~ 6.5 43.4 ~ 47.0	83.4 ~ 88.3 8.5 ~ 9.0 61.5 ~ 65.1	27 mm 1.06 in	M18 × 1.5	30 ~ 50 3.1 ~ 5.1 22.13 ~ 36.9
3/4"	117.7 ~ 127.5 12.0 ~ 13.0 86.8 ~ 94.0	127.5 ~ 147.1 13.0 ~ 15.0 94.0 ~ 108.5	36 mm 1.42 in	M22 × 1.5	40 ~ 60 4.1 ~ 6.1 29.5 ~ 44.25
1"	137.3 ~ 147.1 14.0 ~ 15.0 101.3 ~ 108.5	147.1 ~ 166.7 15.0 ~ 17.0 108.5 ~ 123.0	41 mm 1.61 in		

## (5) Joint bodies

Thread size (piping screw)	Tightening torque N·m kgf·m ft·lbf		Spanner size (reference)	Remarks Steel pipe (OD)	
	R (tapered thread)	G (straight thread)			
1/8"	19.6 ~ 29.4 N·m 2.0 ~ 3.0 kgf·m 14.5 ~ 21.7 ft·lbf	-	17 mm 0.67 in		8 mm 0.31 in
1/4"	36.3 ~ 44.1 3.7 ~ 4.5 26.8 ~ 32.5	W/O-ring <i>Joint Torque</i> 58.8 ~ 78.5 6 ~ 8 43.4 ~ 57.9	19 mm 0.75 in	When in steel pipe is in use.	12 mm 0.47 in
3/8"	39.2 ~ 49.0 4.0 ~ 5.0 28.9 ~ 36.2	W/O-ring <i>Joint Torque</i> 78.5 ~ 98.1 8 ~ 10 57.9 ~ 72.3	23 mm 0.91 in		15 mm 0.59 in
1/2"	49.0 ~ 68.6 5.0 ~ 7.0 36.2 ~ 50.6	W/O-ring <i>Joint Torque</i> 117.7 ~ 137.3 12 ~ 14 86.8 ~ 101.3	26 mm 1.02 in		16 mm 0.63 in

## (6) Tightening torque table for hose clamp (Screw type)



No.	Dia. (mm)	Code No.	Tightening torque N·m kgf·m ft·lbf
1	Ø12 ~ 16	09318-89016	2.5 ~ 3.4 25 ~ 35 1.84 ~ 2.51
2	Ø19 ~ 25	09318-89024	
3	Ø31 ~ 40	09318-89039	
4	Ø36 ~ 46	09318-89045	
5	Ø15 ~ 25	RC101-64580	4.9 ~ 5.9 50 ~ 60 3.61 ~ 4.35
6	Ø26 ~ 38	68311-72820	
7	Ø13 ~ 20	RB101-63630	3.4 ~ 4.4 35 ~ 45 2.58 ~ 3.31
8	Ø40 ~ 55	RC411-63180	4.9 ~ 5.9 50 ~ 60 3.61 ~ 4.35
9	Ø77 ~ 95	69284-63170	
10	Ø50 ~ 60	RC401-63190	
11	Ø32 ~ 44	RD411-63820	

## (7) Nuts for piping

Steel pipe size (O.D. × I.D. × Thickness)	Tightening torque N·m kgf·m ft·lbf	Spanner size (reference)	Remarks
8 × 6 × 1 mm 0.31 × 0.24 × 0.04 in	29.4 ~ 39.2 3.0 ~ 4.0 21.7 ~ 28.9	17 mm 0.67 in	When sleeve nut is in use.
10 × 7 × 1.5 mm 0.39 × 0.28 × 0.06 in	39.2 ~ 44.1 4.0 ~ 4.5 28.9 ~ 32.5	19 mm 0.75 in	
12 × 9 × 1.5 mm 0.47 × 0.35 × 0.06 in	53.9 ~ 63.7 5.5 ~ 6.5 39.7 ~ 47.0	21 mm 0.83 in	
16 × 12 × 2 mm 0.63 × 0.47 × 0.08 in	88.3 ~ 98.1 9.0 ~ 10.0 65.1 ~ 72.3	29 mm 1.14 in	
18 × 14 × 2 mm 0.71 × 0.55 × 0.08 in	127.5 ~ 137.3 13.0 ~ 14.0 94.0 ~ 101.3	32 mm 1.26 in	
27.2 × 21.6 × 2.8 mm 1.07 × 0.85 × 0.11 in	235.4 ~ 254.97 24.0 ~ 16.0 173.6 ~ 188.1	41 mm 1.61 in	

**(8) Tightening torque of bolts and nuts**

Refer to the tightness torque table below.

Bolts, Nuts Nomial Dia.	4T 	7T 	9T 
	SS41	S40C, S45C	SCr4
M6	7.8 ~ 9.3 N·m 0.80 ~ 0.95 kgf·m 5.8 ~ 6.9 ft·lbf	9.8 ~ 11.3 N·m 1.00 ~ 1.15 kgf·m 7.2 ~ 8.3 ft·lbf	12.3 ~ 14.2 N·m 1.25 ~ 1.45 kgf·m 9.0 ~ 10.5 ft·lbf
M8	17.7 ~ 20.6 N·m 1.80 ~ 2.10 kgf·m 13.0 ~ 15.2 ft·lbf	23.5 ~ 27.5 N·m 2.40 ~ 2.80 kgf·m 17.4 ~ 20.3 ft·lbf	29.4 ~ 34.3 N·m 3.00 ~ 3.50 kgf·m 21.7 ~ 25.3 ft·lbf
M10	39.2 ~ 45.1 N·m 4.00 ~ 4.60 kgf·m 28.9 ~ 33.3 ft·lbf	48.0 ~ 55.9 N·m 4.90 ~ 5.70 kgf·m 35.4 ~ 41.2 ft·lbf	60.8 ~ 70.6 N·m 6.20 ~ 7.20 kgf·m 44.8 ~ 52.1 ft·lbf
M12	62.8 ~ 72.6 N·m 6.40 ~ 7.40 kgf·m 46.3 ~ 53.5 ft·lbf	77.5 ~ 90.2 N·m 7.90 ~ 9.20 kgf·m 57.1 ~ 66.5 ft·lbf	103.0 ~ 117.7 N·m 10.50 ~ 12.00 kgf·m 75.9 ~ 86.8 ft·lbf
M14	107.9 ~ 125.5 N·m 11.00 ~ 12.80 kgf·m 79.6 ~ 92.6 ft·lbf	123.6 ~ 147.1 N·m 12.60 ~ 15.0 kgf·m 91.1 ~ 108.5 ft·lbf	166.7 ~ 196.1 N·m 17.00 ~ 20.00 kgf·m 123.0 ~ 144.7 ft·lbf
M16	166.7 ~ 191.2 N·m 17.00 ~ 19.50 kgf·m 123.0 ~ 141.0 ft·lbf	196.1 ~ 225.6 N·m 20.00 ~ 23.00 kgf·m 144.7 ~ 166.4 ft·lbf	259.9 ~ 304.0 N·m 26.50 ~ 31.00 kgf·m 191.7 ~ 224.2 ft·lbf
M18	245.2 ~ 284.4 N·m 25.00 ~ 29.0 kgf·m 180.8 ~ 209.7 ft·lbf	274.6 ~ 318.7 N·m 28.00 ~ 32.50 kgf·m 202.5 ~ 235.1 ft·lbf	343.2 ~ 402.1 N·m 35.00 ~ 41.00 kgf·m 253.2 ~ 296.5 ft·lbf
M20	333.4 ~ 392.2 N·m 34.00 ~ 40.00 kgf·m 245.9 ~ 389.3 ft·lbf	367.7 ~ 431.5 N·m 37.50 ~ 44.0 kgf·m 271.2 ~ 318.2 ft·lbf	519.8 ~ 568.8 N·m 53.00 ~ 58.00 kgf·m 383.3 ~ 419.5 ft·lbf

**(9) Types and materials of bolts and nuts**

[ex. bolts]

Types	Material	Tensile strength	Hardness	Bolt head marking	
4T	SS41	Over 392 MPa 4000 kgf/cm <sup>2</sup> 56892 lbf/in <sup>2</sup>	H <sub>R</sub> B 62 ~ 98		No mark or marked 4
7T	S40C S45C	Over 686 MPa 7000 kgf/cm <sup>2</sup> 99561 lbf/in <sup>2</sup>	H <sub>R</sub> C 20 ~ 28		Marked 7
9T	SCr4	Over 882 MPa 9000 kgf/cm <sup>2</sup> 128007 lbf/in <sup>2</sup>	H <sub>R</sub> C 28 ~ 34		Marked 9

## (10)Washer-equipped elbow

## Tightening torque

Size	N·m	kgf·m	ft·lbs
G1/4	25 ~ 30	2.5 ~ 3.0	18 ~ 22
G3/8	49 ~ 54	5.0 ~ 5.5	36 ~ 40
G1/2	59 ~ 64	6.0 ~ 6.5	43 ~ 47
G3/4 G1	118 ~ 127	12.0 ~ 13.0	87 ~ 94

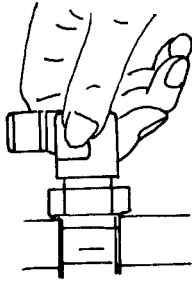

## Tightening procedure

1. Connecting with the valve
  - Screw in the elbow by hand until the washer comes into contact.

**Note:** Clean up the mating seal beforehand.

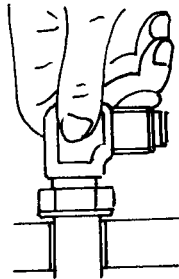

2. Positioning

- Turn the elbow back to its set position.

**Note:** Do not make any more than one turn back.

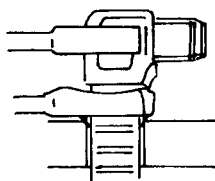

3. Fixing

- Tighten up the lock nut with a wrench.
- Lock nut tightening torque

# F. Maintenance intervals

## a. Maintenance intervals chart : EU-version

General Maintenance	Elapsed Operating Hours																				Interval		
	50	100	150	200	250	300	350	400	450	500	550	600	650	700	750	800	850	900	950	1000			
Operator Services	Check engine oil level																					daily	
	Check hydraulic oil level																						daily
	Check fuel level																						daily
	Check coolant level																						daily
	Grease front attachments																						daily
	Check V-belt																						daily
	Check washer liquid																						daily
	Check water separator																						daily
	Grease swivel gear	○	○	○	○	○	○	○	○	○	○	○	○	○	○	○	○	○	○	○	○	○	50 h
	Check, clean air filter 1.)	○	○	○	○	○	○	○	○	○	○	○	○	○	○	○	○	○	○	○	○	○	50 h
	Grease swivel gear bearing				○				○				○				○					○	200 h
	Check battery electrolyte level									○												○	500 h
	Drain water in fuel tank									○												○	500 h

**IMPORTANT:**

- ● First operation
  - 1.) Clean the air filter more frequently if used under dusty conditions. By heavy soiling, replace the filter.
  - 2.) When using a hydraulic breaker, change hydraulic oil and return filter according to the table on "Hydraulic Oil Change".
  - 3.) Earlier if necessary.
  - 4.) At least annually.
- (including Exchange of the Suction Filter in the Hydraulic Tank) under "EVERY 1000 SERVICE HOURS" in "REGULAR CHECKS AND MAINTENANCE WORK".

Service	Elapsed Operating Hours																				Interval		
	50	100	150	200	250	300	350	400	450	500	550	600	650	700	750	800	850	900	950	1000			
Servicing by skilled personnel or KUBOTA dealer	Change engine oil and oil filter	●			○					○					○						○	250 h	
	Inspect coolant hoses and clamps				○					○					○							○	250 h
	Check/adjust V-belt tension				○					○					○							○	250 h
	Grease pilot valve linkage				○					○					○							○	250 h
	Change fuel filter cartridge 3.)																					○	500 h
	Drain of the water separator									○												○	500 h
	Change hydraulic return line filter element					●				○												○	500 h
	Change drive unit oil 4.)		●							○												○	500 h
	Change hydraulic oil and suction filter 2.)																					○	1000 h
	Renewing the pilot circuit filter																					○	1000 h
	Change air filter elements 1.)																					○	1000 h
	Change idler and track roller oil																						2000 h
	Check alternator and starter motor																						Please contact your KUBOTA dealer. 2000 h
	Inspect electric cables and connections																						Please contact your KUBOTA dealer. annually
	Change coolant																						every 2 years
	Change hydraulic hoses																						Please contact your KUBOTA dealer. every 6 years
Safety inspection																						annually	

b.Maintenance intervals chart : PP-version

No.	Check points		Intervals	Hour meter indicator								Consequently	Ref. page			
				50	100	150	200	250	300	350	400					450
1	Coolant		check	Daily check												
			change										every 2 years			
2	Fuel		check	Daily check												
3	Engine oil		check	Daily check												
			change	●					○				every 250 hrs			
4	Hydraulic oil		check	Daily check												
			change										every 1000 hrs		*1	
5	Lubrication points		-	Daily check												
6	Radiator and oil cooler		check	Daily check												
7	Engine and electrical wiring		check	Daily check								every year				
8	Fuel tank, Water separator		drain	○	○	○	○	○	○	○	○	○	every 50 hrs			
9	Battery condition		check	○	○	○	○	○	○	○	○	○	every 50 hrs			
10	Greasing swing bearing teeth		-	○	○	○	○	○	○	○	○	○	every 50 hrs			
11	Fan belt tension		check	Daily check												
			adjust				○				○		every 200 hrs			
12	Radiator hoses and clamps		check				○				○	every 200 hrs				
			replace										every 2 years			
13	Air filter element	Outer element	clean				○				○	every 200 hrs		*2	@	
		Inner element	replace									every 1000 hrs		*2		
			replace										every 1000 hrs			*2
14	Greasing swing ball bearings		-				○				○	every 200 hrs				
15	Fuel filter cartridge		replace									every 500 hrs			@	
16	Engine oil filter		replace	●					○			every 250 hrs				
17	Drive unit oil		change		●							every 500 hrs				
18	Hydraulic return filter element		replace				●					every 500 hrs				
19	Hydraulic suction filter element		replace									every 1000 hrs				
20	Filter in the pilot hydraulic system		replace									every 1000 hrs				
21	Fuel injection nozzle injection pressure		check									every 1500 hrs		*4	@	
22	Front idler and track roller oil		change									every 2000 hrs				
23	Alternator and starter motor		check									every 2000 hrs				
24	Injection pump		check									every 3000 hrs		*4	@	
25	Radiator system		rinse									every 2 years				
26	Fuel line and Intake air line		check				○				○	every 200 hrs			@	
			replace									every 2 years		*3		
27	Greasing pilot valve linkage		-				○					every 250 hrs				
28	Pilot circuit filter		clean									every 1000 hrs				

D 500 thru 1000 continued to the following table.

No.	Check points		Intervals	Hour meter indicator							Consequently	Ref. page			
				500	550	600	650	700	750	800					1000
1	Coolant		check	Daily check											
			change									every 2 years			
2	Fuel		check	Daily check											
			change									every 250 hrs			
3	Engine oil		check	Daily check											
			change		○					○		every 250 hrs			
4	Hydraulic oil		check	Daily check											
			change								○	every 1000 hrs		*1	
5	Lubrication points		-	Daily check											
6	Radiator and oil cooler		check	Daily check											
7	Engine and electrical wiring		check	Daily check							every year				
8	Fuel tank, Water separator		drain	○	○	○	○	○	○	○	○	every 50 hrs			
9	Battery condition		check	○	○	○	○	○	○	○	○	every 50 hrs			
10	Greasing swing bearing teeth		-	○	○	○	○	○	○	○	○	every 50 hrs			
11	Fan belt tension		check	Daily check											
			adjust			○				○	○	every 200 hrs			
12	Radiator hoses and clamps		check			○				○	○	every 200 hrs			
			replace										every 2 years		
13	Air filter element	Outer element	clean			○				○	○	every 200 hrs		*2	@
			replace								○	every 1000 hrs		*2	
		Inner element	replace								○	every 1000 hrs		*2	
14	Greasing swing ball bearings		-			○				○	○	every 200 hrs			
15	Fuel filter cartridge		replace	○							○	every 500 hrs			@
16	Engine oil filter		replace		○					○		every 250 hrs			
17	Drive unit oil		change			○						every 500 hrs			
18	Hydraulic return filter element		replace						○			every 500 hrs			
19	Hydraulic suction filter element		replace								○	every 1000 hrs			
20	Filter in the pilot hydraulic system		replace								○	every 1000 hrs			
21	Fuel injection nozzle injection pressure		check									every 1500 hrs		*4	@
22	Front idler and track roller oil		change									every 2000 hrs			
23	Alternator and starter motor		check									every 2000 hrs			
24	Injection pump		check									every 3000 hrs		*4	@
25	Radiator system		rinse									every 2 years			
26	Fuel line and Intake air line		check			○				○	○	every 200 hrs			@
			replace									every 2 years		*3	
27	Greasing pilot valve linkage		-	○					○		○	every 250 hrs			
28	Pilot circuit filter		clean									every 1000 hrs			

## c. Water and oil quantity

	Unit	U20-3α	U25-3α	U25S	Remarks	
Radiator	Canopy / Cab	L gal	3.0 0.79	←	←	Kubota LLC-N-50F 50%
Reserve tank		L gal	0.6 0.16	←	←	
Engine oil with filter		L gal	4.4 1.16	←	←	SAE10W30(CF-4)
Hydraulic oil	Full	L gal	37.0 9.98	←	←	ISO 46
Hydraulic oil	Tank gauge center	L gal	22.5 5.94	←	←	ISO 46
Wheel motor		L gal	0.33 0.09	0.35 0.09	←	SAE90 (API GL-4)
Track roller		cc gal	50 0.01	80 0.02	←	SAE30(CD)
Upper roller		cc gal	60 0.02	←	←	SAE30(CD)
Front idler		cc gal	35 0.01	75 0.02	←	SAE30(CD)
Fuel tank		L gal	27.5 7.27	←	←	

Grease	Supply grease to such amount that it oozes out of periphery of the rotating end.	Ultra -pressure grease : EP2, Beacon Q2
Control lever and links Du-bushing	Assemble after applying grease	

### Inspection of hydraulic oil

When checking the hydraulic oil level, satisfy the following conditions and make sure the oil level is above the center the oil gauge.

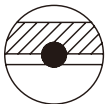

The oil level is within the shaded area shown in the figure at left.

- 1) Oil temp. should be between 10 ~ 30 °C (50 ~ 86 °F)
- 2) Stance of front attachment :  
 Swing : Straight forward  
 Arm : Vertical to the ground  
 Bucket : On the ground at its bottom  
 Dozer blade : Down to the ground

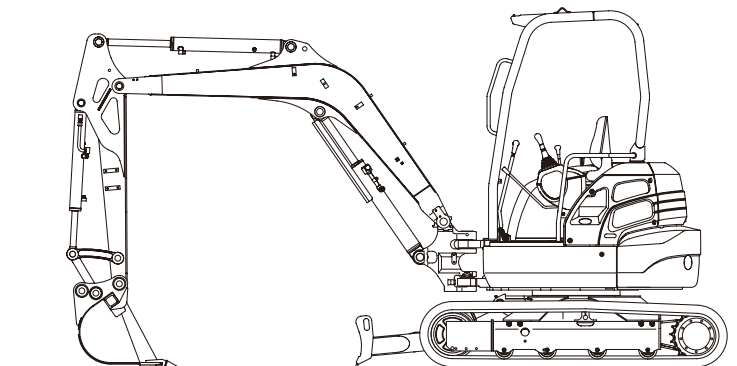

## d. Recommended oil

### IMPORTANT:

1. Before delivery the hydraulic oil used was an ISO 46 viscosity grade.
2. Use engine oil API service classification CD, CE or CF.
3. Use SAE 90 (API, CLA/GL5) as drive unit oil for all seasons.

	Application	Viscosity	Shell	Mobil	Exxon	MIL-Standard
Engine oil	In winter or by low temperatures	SAE 10W	Shell Rotella T10W Shell Rimula 10W	Mobil Delvac 1310	XD-3 10W XD-3 Extra 10W	MIL-L-2104C MIL-L-2104D
		SAE 20W	Shell Rotella T20W-2 Shell Rimula 20W-2	Mobil Delvac 1320	XD-3 20W-20 XD-3 Extra 20W-20	
	In summer or by high ambient temperatures	SAE 30	Shell Rotella T30 Shell Rimula 30	Mobil Delvac 1330	XD-3 30 XD-3 Extra 30	
		SAE 40	Shell Rotella T40 Shell Rimula 40	Mobil Delvac 1340	XD-3 40 XD-3 Extra 40	
	All-Season Engine oil	Multi-purpose	Shell Rotella T15W		XD-3 15W-40 XD-3 Extra 15W-40	
Gear oil	In winter or by low temperatures	SAE 75		Mobilube HD80W-90		MIL-L-2105C
			Shell Oil S8643			
		SAE 80		Mobilube HD80W-90		MIL-L-2105
			Shell Spirax HD80W			
	In summer or by high ambient temperatures	SAE 90		Mobilube 46		MIL-L-2105
			Shell Spirax HD90	Mobilube HD80W-90		MIL-L-2105C
	SAE 140		Mobilube HD85W-140		MIL-L-2105C	
		Shell Spirax HD140	Mobilube HD80W-140		MIL-L-2105C	
All-weather gear oil	Multi-purpose	Shell Spirax HD80W Shell Spirax HD85W	Mobilube HD80W-90	GX80W-90	MIL-L-2105C	
Hydraulic oil	In winter or by low temperatures	ISO 32	Shell Tellus T32	Mobil DTE-Oil 13	NUTO H32	
		ISO 46	Shell Tellus T46	Mobil DTE-Oil 15	NUTO H46	
	In summer or by high ambient temperatures	ISO 68	Shell Tellus T68	Mobil DTE-Oil 16	NUTO H68	
Grease		Shell Alvania EP2	Mobilux EP2	BEACON Q2		
Fuel		Light oil No. 2-D (ASTM D975)				
Fuel under -5 °C (+23 °F)		Light oil No. 1-D (ASTM D975)				

## e Hydraulic Oil Check for machines with Hydraulic Breakers

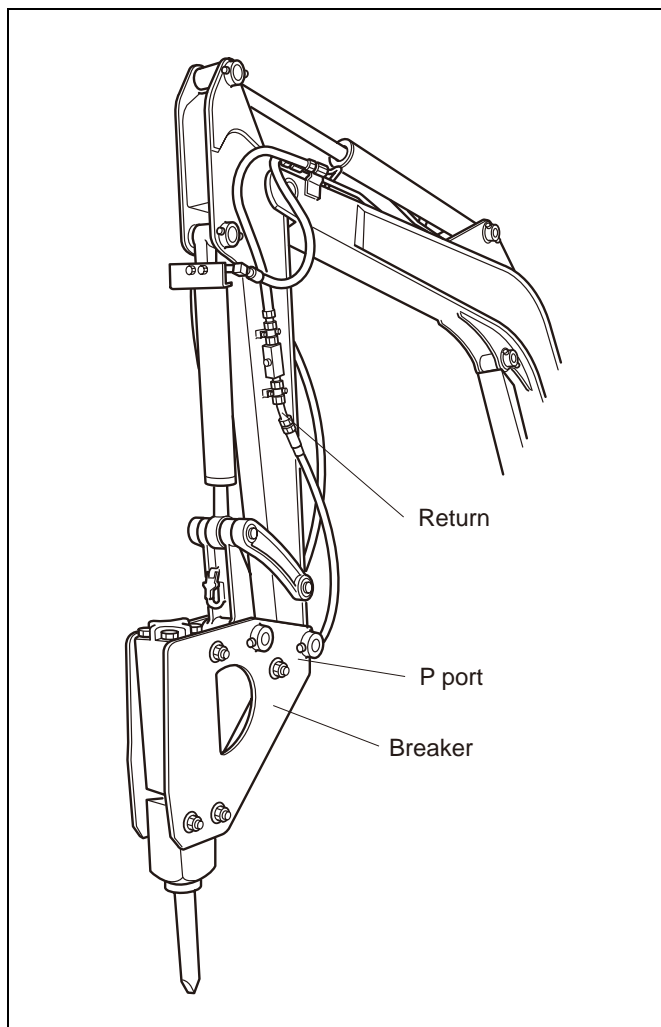

The Hydraulic oil change after 1000 operating hours in the operator's manual is based on the type of work done. Following inspection measure are valid when hydraulic breakers are used:

- (1) Changing and filling up of hydraulic oil
  1. The hydraulic oil must be changed more often when breakers are used because the machine is subject to harder conditions than at normal excavating work.
  2. Use only the recommended oils mentioned in the operator's manual when changing or fill oil.
  3. When filling up oil, never mix oils of different makes.
- (2) Changing the return filter and oil
  1. The filter must be changed more often because of contamination resulting from the frequent assembly and disassembly of the hoses.
  2. Use the correct replacement filter.
  3. Oil change according to operating hours.

		Hydraulic oil	Return Filter	Suction Filter
Normal excavator work		every 1000 Hrs.	500 Hrs.	1000 Hrs.
Breaker work portion	20%	every 800 Hrs.	300 Hrs.	
	40%	every 400 Hrs.		
	60%	every 300 Hrs.	100 Hrs.	
	More than 80%	every 200 Hrs.		

(Other attachments for service port)

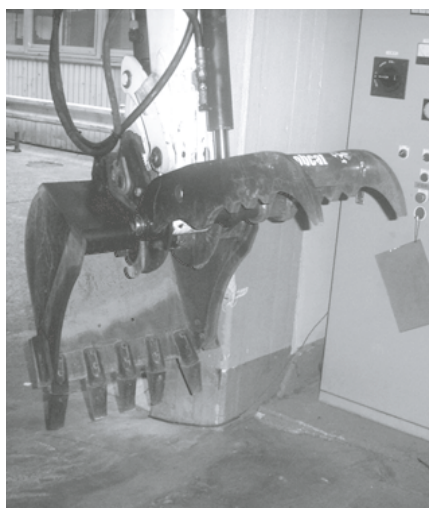

Thumb

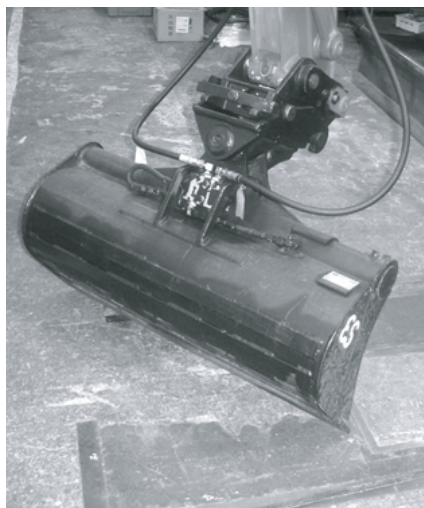

Tilt bucket

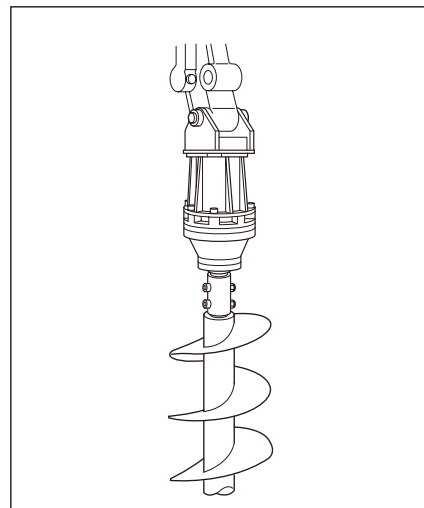

Auger

## SERVICE PORT OPERATION



### CAUTION

To avoid personal injury:

- Tilt the service port pedal forward when the pedal is not used. Be sure to lock the pedal.

This pedal is used to operate hydraulic attachments such as breakers or others.

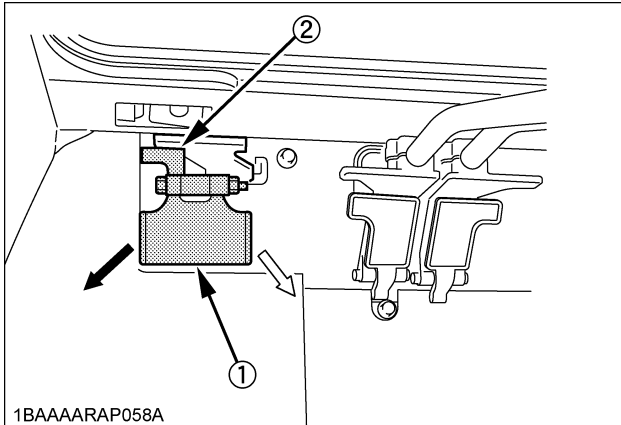

- (1) Service port pedal
- (2) Pedal lock

- Push the front part of the pedal (⇩), send oil to the pipe (1).
- Push the back part of the pedal (⇩), send oil to the pipe (2).

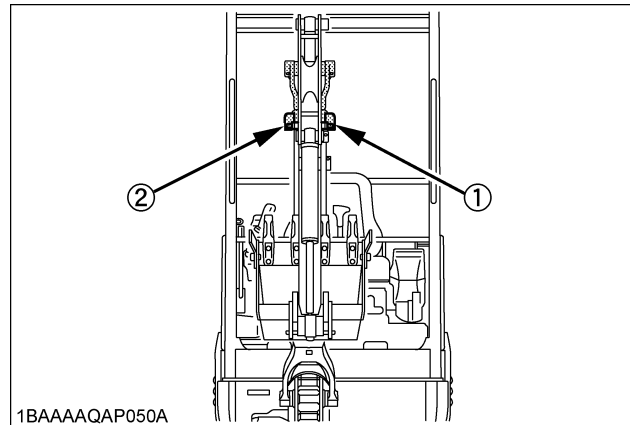

### IMPORTANT :

- When the service port is not used for a long period, dirt particles can settle in the lower part of the service port lines. When the plugs on the service port lines are removed to connect attachments, drain approx. 3.4oz(100 cc) of oil per side before making connections. Concerning the choice of a breaker, contact your dealer.

Max. Flow Volume LPM (GPM) (No load, theoretical)	<b>U20-3<math>\alpha</math></b>	35.8 (9.46)
	<b>U25-3<math>\alpha</math>, U25S</b>	48.0 (12.68)
Max. Pressure MPa (kgf/cm <sup>2</sup> ) (psi)	<b>U20-3<math>\alpha</math></b>	21.6 (220) (3129)
	<b>U25-3<math>\alpha</math>, U25S</b>	

## f. Periodic replacement of important parts

To ensure safety in traveling and operating the machine, the user is strongly requested to carry out periodic inspection and servicing. For added safety, the following important parts, related to safety and fire hazards in particular, must be replaced at their specified intervals.

With the passage of time, these parts easily get degraded in material or worn out. They are difficult to check for anything unusual even at periodic inspection and servicing. Even if nothing unusual is found, it is essential to replace them with new ones after their specified service life, in order to maintain complete function.

If by any chance any of these parts gets in trouble even before its service life, it must be repaired or replaced as usual.

In replacing the hoses, check also the hose clamps for deformation, cracks and other troubles. Replace the hose clamps too with new ones, as required.

Check all the hydraulic hoses, including those to be replaced at regular intervals, for the following points. Tighten up or replace them, as required.

When replacing the hydraulic hoses, change their O-rings and sealing for new ones at the same time.

- Check the fuel and hydraulic hoses too at the following periodic inspections.

Inspection intervals	Inspection item
Daily inspection	Fuel and hydraulic hose connections as well as crimped parts for oil leak
Monthly inspection	Fuel and hydraulic hose connections as well as crimped parts for oil leak Fuel and hydraulic hoses for damages (cracks, wear-out and peel-off)
Specified self-imposed (yearly) inspection	Fuel and hydraulic hose connections as well as crimped parts for oil leak Fuel and hydraulic hoses for interference, deformation, degrading, twist and other damages (cracks, wear-out, peel-off)

- List of important parts

No.	Periodic-replaced parts	Q'ty	Replacement intervals
1	Fuel hose (Fuel tank ~ Fuel filter)	1	2 years or 4000 operating hours, whichever comes earlier
2	Fuel hose (Fuel filter ~ Fuel pump)	1	
3	Fuel hose (Fuel pump ~ Fuel nozzle)	1	
4	Fuel hose (Fuel nozzle ~ Fuel tank)	1	
5	Hydraulic hose (Main pump suction)	1	
6	Hydraulic hose (Main pump delivery)	4	
7	Hydraulic hose (Boom cylinder)	*2	
8	Hydraulic hose (Arm cylinder)	*2+2	
9	Hydraulic hose (Bucket cylinder)	*4	
10	Hydraulic hose (Swing cylinder)	2	
11	Hydraulic hose (Dozer cylinder)	4	
12	Hydraulic hose (Service port)	*2+2	
13	Hydraulic hose (Swivel motor)	2	

Note: The \*-marked hydraulic hoses are Kubota's genuine ultra wear-resistant hoses. Be sure to use these parts.

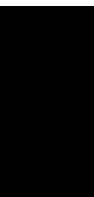

## II Machine Body

A. Specifications . . . . .	II-S-3
B. Front attachment . . . . .	II-S-14
C. Upper structure . . . . .	II-S-28
D. Cab / canopy installation . . . . .	II-S-43
E. Under carriage . . . . .	II-S-63
F. Variable track (U20-3 $\alpha$ ) . . . . .	II-S-73
G. Label . . . . .	II-S-91

Product: Kubota WSM U20-3,U25-3,U25S- Excavator Service Repair Workshop Manual(Service Chapter)

Full Download: <https://www.arepairmanual.com/downloads/kubota-wsm-u20-3u25-3%ce%b1u25s%ce%b1-excavator-service-repair-workshop-manualservice-chapter/>

Sample of manual. Download All 478 pages at:

<https://www.arepairmanual.com/downloads/kubota-wsm-u20-3u25-3%ce%b1u25s%ce%b1-excavator-service-repair-workshop>