

KUBOTA

Workshop Manual

05 Series

Diesel Engine

Product: 1996 Kubota WSM 05 Series Diesel Engine Service Repair Workshop Manual
Full Download: <https://www.arepairmanual.com/downloads/1996-kubota-wsm-05-series-diesel-engine-service-repair-workshop-manual/>

Sample of manual. Download All 124 pages at:
<https://www.arepairmanual.com/downloads/1996-kubota-wsm-05-series-diesel-engine-service-repair-workshop-manual/>

TO THE READER

This Workshop Manual has been prepared to provide servicing personnel with information on the mechanism, service and maintenance of KUBOTA Diesel Engines 05 SERIES. It is divided into two parts, "Mechanism" and "Disassembling and Servicing" for each section.

■ Mechanism

Information on the construction and function are included for each engine section. This part should be understood before proceeding with troubleshooting, disassembling and servicing.

■ Disassembling and Servicing

Under the heading "General" section comes general precautions, troubleshooting, lists of servicing specifications and periodic inspection items. For each engine section, there are "Checking and Adjustment", "Disassembling and Assembling", and "Servicing" which cover procedures, precautions, factory specification and allowable limits.

All the engines that have been manufactures since January of 1994 are clean exhaust engines.

The mark [E] in the WSM refers to the said clean engine.

All information, illustrations and specifications contained in this manual are based on the latest production information available at the time of publication.

The right is reserved to make changes in all information at any time without notice.

Due to covering many models of this manual, illustration or picture being used have not been specified as one model.

May '96

© KUBOTA Corporation 1996

01640Z00040

SAFETY FIRST

This symbol, the industry's "Safety Alert Symbol", is used throughout this manual and decals on the engine itself to warn of the possibility of personal injury. Read these instructions carefully.

It is essential that you read the instructions and safety regulations before you attempt to repair or use this unit.



DANGER : Indicates an imminently hazardous situation which, if not avoided, will result in death or serious injury.



WARNING: Indicates a potentially hazardous situation which, if not avoided, could result in death or serious injury.



CAUTION : Indicates a potentially hazardous situation which, if not avoided, may result in minor or moderate injury.



IMPORTANT : Indicates that equipment or property damage could result if instructions are not followed.



NOTE : Gives helpful information.

00000Z00011

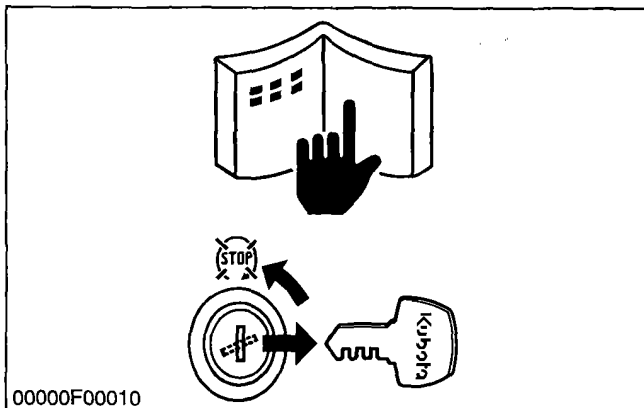

BEFORE SERVICING AND REPAIRING

- (1) Read all instructions and safety instructions in this manual and on your engine safety decals.
- (2) Clean the work area and engine.
- (3) Place the engine on a firm and level ground.
- (4) allow the engine to cool before proceeding.
- (5) Stop the engine, and remove the key.
- (6) Disconnect the battery negative cable.

00000Z00021



SAFETY STARTING

- (1) Do not start the engine by shorting across starter terminals.
- (2) Unauthorized modifications to the engine may impair the function and / or safety and affect engine life.

00000Z00031

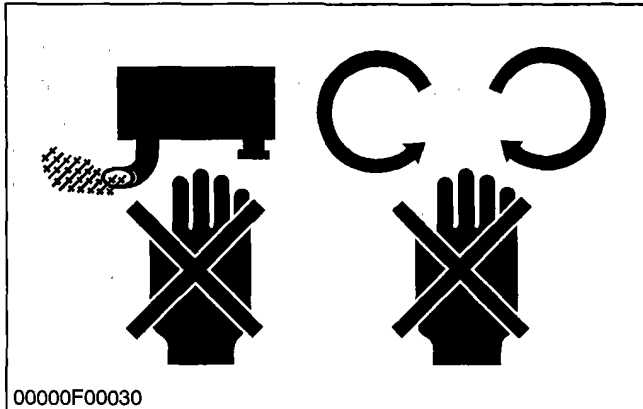

SAFETY WORKING

- (1) Do not work on the engine **while** under the influence of alcohol, medication, or **other substances** or while fatigued.
- (2) Wear close fitting clothing and safety equipment appropriate to the job.
- (3) Use tools appropriate to the work. Makeshift tools, parts, and procedures are not recommended.
- (4) When servicing is performed together by two or more persons, take care to perform all work safely.
- (5) Do not touch the rotating or hot parts while the engine is running.
- (6) Never remove the radiator cap while the engine is running, or immediately after stopping. Otherwise, hot water will spout out from radiator. Only remove radiator cap when cool enough to touch with bare hands. Slowly loosen the cap to first stop to relieve pressure before removing completely.
- (7) Escaping fluid (fuel or hydraulic oil) under pressure can penetrate the skin causing serious injury. Relieve pressure before disconnecting hydraulic or fuel lines. Tighten all connections before applying pressure.
- (8) Wear a suitable hearing protective device such as earmuffs or earplugs to protect against objectionable or uncomfortable loud noises.

00000Z00041

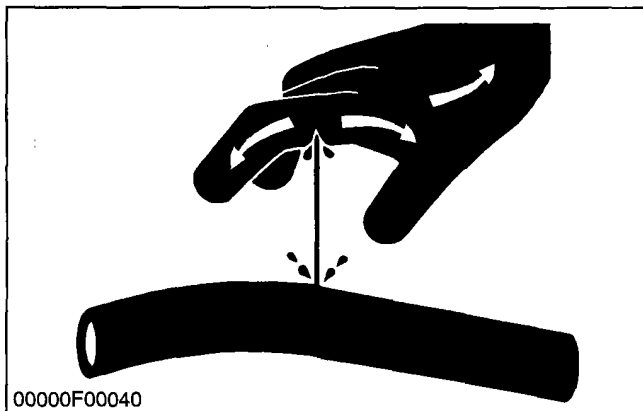

AVOID FIRES

- (1) Fuel is extremely flammable and explosive under certain conditions. Do not smoke or allow flames or sparks in your working area.
- (2) To avoid sparks from an accidental short circuit, **always** disconnect the battery negative cable first and connect it last.
- (3) Battery gas can explode. Keep sparks and open flame away from the top of battery, especially when charging the battery.
- (4) Make sure that no fuel has been spilled on the engine.

00000Z00050

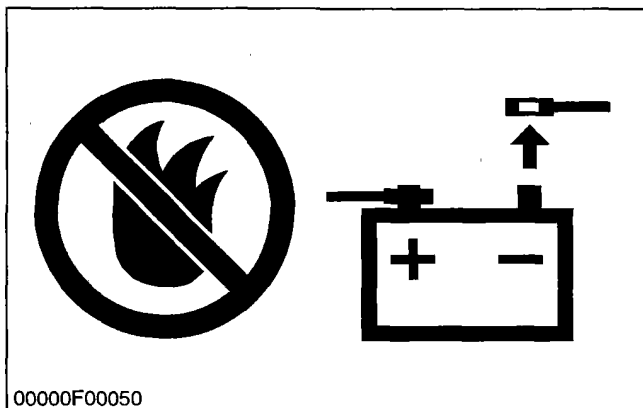

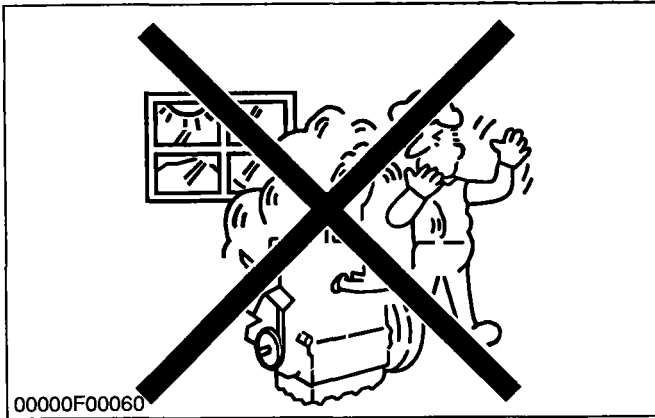

00000F00060

VENTILATE WORK AREA

- (1) If the engine must be running to do some work, make sure the area is well ventilated. Never run the engine in a closed area. The exhaust gas contains poisonous carbon monoxide.

00000Z00060

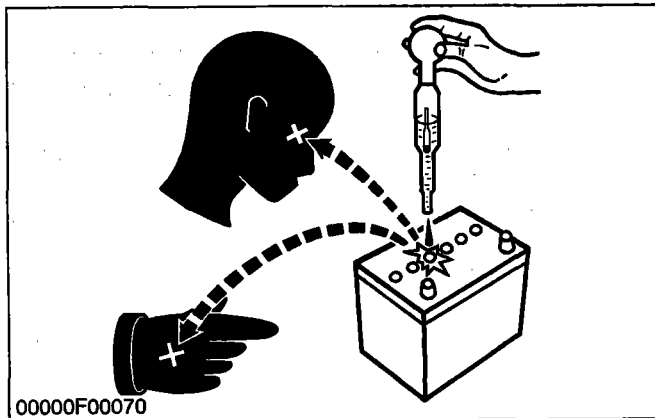

00000F00070

PREVENT ACID BURNS

- (1) Sulfuric acid in battery electrolyte is poisonous. It is strong enough to burn skin, clothing and cause blindness if splashed into eyes. Keep electrolyte away from eyes, hands and clothing. If you spill electrolyte on yourself, flush with water, and get medical attention immediately.

00000Z00070

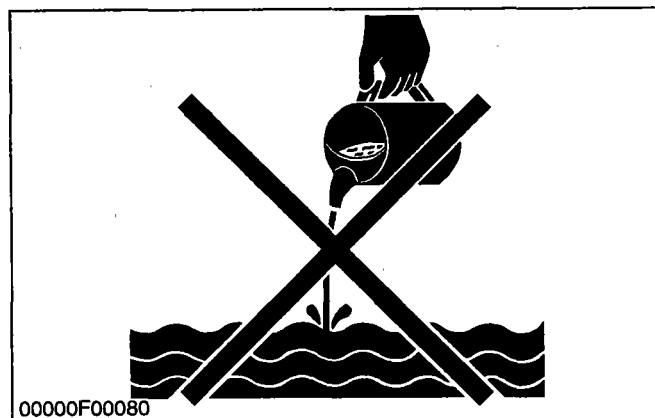

00000F00080

DISPOSE OF FLUIDS PROPERLY

- (1) Do not pour fluids into the ground, down a drain, or into a stream, pond, or lake. Observe relevant environmental protection regulations when disposing of oil, fuel, coolant, electrolyte and other harmful waste.

00000Z00080



00000F00090

PREPARE FOR EMERGENCIES

- (1) Keep a first aid kit and fire extinguisher handy at all times.
- (2) Keep emergency numbers for doctors, ambulance service, hospital and fire department near your telephone.

00000Z00090

SPECIFICATIONS

Model		D905-B (E)		D1005-B (E)		V1205-B (E)		V1205-T-B (E)		V1305-B (E)		
Number of cylinders		3				4						
Type		Vertical, water-cooled, 4-cycle diesel engine										
Bore x stroke mm (in.)		72 x 73.6 (2.83 x 2.90)		76 x 73.6 (2.99 x 2.90)		72 x 73.6 (2.83 x 2.90)				76 x 73.6 (2.99 x 2.90)		
Total displacement cm ³ (cu. in.)		898 (54.86)		1001 (61.08)		1198 (73.10)				1335 (81.46)		
Brake Horsepower	SAE net cont.	kW/rpm (HP/rpm)	12.7/3000 (17.0/3000)	15.3/3600 (20.5/3600)	14.2/3000 (19.0/3000)	16.8/3600 (22.5/3600)	17.2/3000 (23.0/3000)	20.1/3600 (27.0/3600)	21.6/3000 (29.0/3000)	25.7/3600 (34.5/3600)	19.0/3000 (25.5/3000)	22.4/3600 (30.0/3600)
	SAE net intermittent	kW/rpm (HP/rpm)	14.9/3000 (20.0/3000)	17.5/3600 (23.5/3600)	16.8/3000 (22.5/3000)	19.4/3600 (26.0/3600)	20.1/3000 (27.0/3000)	23.5/3600 (31.5/3600)	25.4/3000 (34.0/3000)	29.8/3600 (40.0/3600)	22.4/3000 (30.0/3000)	25.7/3600 (34.5/3600)
	SAE gross intermittent	kW/rpm (HP/rpm)	16.8/3000 (22.5/3000)	19.4/3600 (26.0/3600)	18.7/3000 (25.0/3000)	21.6/3600 (29.0/3600)	22.4/3000 (30.0/3000)	26.1/3600 (35.0/3600)	28.0/3000 (37.5/3000)	32.8/3600 (44.0/3600)	25.0/3000 (33.5/3000)	28.7/3600 (38.5/3600)
	DIN6271-NA	kW/rpm (ps/rpm)	12.5/3000 (17.0/3000)	15.1/3600 (20.5/3600)	14.0/3000 (19.0/3000)	16.5/3600 (22.5/3000)	16.9/3000 (23.0/3000)	19.9/3600 (27.0/3600)	21.3/3000 (29.0/3000)	25.4/3600 (34.5/3600)	18.8/3000 (25.5/3000)	22.1/3600 (30.0/3600)
	DIN6271-NB	kW/rpm (ps/rpm)	14.3/3000 (19.5/3000)	16.5/3600 (22.5/3600)	15.8/3000 (21.5/3000)	18.4/3600 (25.0/3600)	19.1/3000 (26.0/3000)	22.1/3600 (30.0/3600)	24.3/3000 (33.0/3000)	28.3/3600 (38.5/3600)	21.3/3000 (29.0/3000)	24.6/3600 (33.5/3600)
	DIN70020	kW/rpm (ps/rpm)	15.4/3000 (21.0/3000)	18.4/3600 (25.0/3600)	17.3/3000 (23.5/3000)	20.2/3600 (27.5/3600)	21.0/3000 (28.5/3000)	24.3/3600 (33.0/3600)	26.5/3000 (36.0/3000)	31.3/3600 (42.5/3600)	23.2/3000 (31.5/3000)	26.8/3600 (36.5/3600)
Maximum bare speed rpm		3200	3800	3200	3800	3200	3800	3200	3800	3200	3800	
Minimum idling speed rpm		600										
Maximum torque		N·m/rpm kgf·m/rpm ft·lbs/rpm	53.8/2000 5.49/2000 39.71/2000	52.8/2400 5.38/2400 38.91/2400	60.6/2000 6.18/2000 44.7/2000	58.4/2400 5.95/2400 43.0/2400	72.7/2000 7.41/2000 53.60/2000	70.7/2400 7.21/2400 52.15/2400	91.5/2000 9.33/2000 67.48/2000	89.7/2400 9.15/2400 66.18/2400	80.8/2000 8.24/2000 59.60/2000	77.4/2400 7.89/2400 57.07/2400
Combustion Chamber		Spherical type										
Fuel injection pump		Bosch MD type mini pump										
Governor		Centrifugal mechanical governor										
Direction of rotation		Counter-clockwise (viewed from flywheel side)										
Injection nozzle		Mini nozzle (DNOPI)										
Injection timing	Without timer	18 to 20° (0.31 to 0.35 rad.) before T.D.C.	21 to 23° (0.37 to 0.40 rad.) before T.D.C.	18 to 20° (0.31 to 0.35 rad.) before T.D.C.	21 to 23° (0.37 to 0.40 rad.) before T.D.C.	18 to 20° (0.31 to 0.35 rad.) before T.D.C.	21 to 23° (0.37 to 0.40 rad.) before T.D.C.	18 to 20° (0.31 to 0.35 rad.) before T.D.C.	21 to 23° (0.37 to 0.40 rad.) before T.D.C.	18 to 20° (0.31 to 0.35 rad.) before T.D.C.	21 to 23° (0.37 to 0.40 rad.) before T.D.C.	
	With timer	8 to 10° (0.14 to 0.17 rad.) before T.D.C.	9 to 11° (0.16 to 0.19 rad.) before T.D.C.	8 to 10° (0.14 to 0.17 rad.) before T.D.C.	9 to 11° (0.16 to 0.19 rad.) before T.D.C.	8 to 10° (0.14 to 0.17 rad.) before T.D.C.	9 to 11° (0.16 to 0.19 rad.) before T.D.C.	8 to 10° (0.14 to 0.17 rad.) before T.D.C.	9 to 11° (0.16 to 0.19 rad.) before T.D.C.	8 to 10° (0.14 to 0.17 rad.) before T.D.C.	9 to 11° (0.16 to 0.19 rad.) before T.D.C.	
Firing order		1-2-3				1-3-4-2						
Injection pressure		140 kgf/cm ² (13.73 MPa, 1991 psi)										
Compression ratio		22 : 1										
Lubricating system		Forced lubrication by pump										
Oil pressure indicating		Electrical type switch										
Lubricating filter		Full flow paper filter (cartridge type)										
Cooling system		Pressurized radiator, forced circulation with water pump (not included in the basic engine)										
Starting system		Electric starting with starter										
Starting support device		12 V, 0.9 kW	12 V, 1.0 kW				12 V, 1.2 kW					
Battery		12 V, 65 AH, equivalent				12 V, 70 AH, equivalent						
Dynamo for charging		12 V, 150 W	12 V, 360 W									
Fuel		Diesel fuel No. 2-D (ASTM D975)										
Lubricating oil		MIL-L-46152, MIL-L-2104C, quality better than CD class (API)						Quality better than CE class (API)		Quality better than CD class (API)		
Lubricating oil capacity	125 mm (4.92 in.)	5.1 L (5.39 U.S.qts., 4.49 Imp.qts.)				6.0 L (6.34 U.S.qts., 5.28 Imp.qts.)		6.7 L (7.08 U.S.qts., 5.90 Imp.qts.)		6.0 L (6.34 U.S.qts., 5.28 Imp.qts.)		
	101 mm (3.97 in.)	4.0 L (4.23 U.S.qts., 3.52 Imp.qts.)				4.7 L (4.97 U.S.qts., 4.14 Imp.qts.)		—		4.7 L (4.97 U.S.qts., 4.14 Imp.qts.)		
Weight (Dry) kg (lbs)		93.0 (205.0)				110.0 (242.5)		114.0 (251.3)		110.0 (242.5)		

01640Z00070

Model		D1105-B (E)	V1505-B (E)	D1105-T-B (E)	V1505-T-B (E)
Number of cylinders		3	4	3	4
Type		Vertical, water-cooled, 4-cycle diesel engine			
Bore x stroke mm (in.)		78 x 78.4 (3.07 x 3.09)			
Total displacement cm ³ (cu. in.)		1123 (68.53)	1498 (91.41)	1123 (68.53)	1498 (91.41)
Brake horsepower	SAE net cont. kW/rpm (HP/rpm)	16.4/3000 (22.0/3000)	21.6/3000 (29.0/3000)	20.5/3000 (27.5/3000)	27.2/3000 (36.5/3000)
	SAE net intermittent kW/rpm (HP/rpm)	18.7/3000 (25.0/3000)	25.0/3000 (33.5/3000)	23.5/3000 (31.5/3000)	31.3/3000 (42.0/3000)
	SAE gross intermittent kW/rpm (HP/rpm)	20.9/3000 (28.0/3000)	28.0/3000 (37.5/3000)	26.1/3000 (35.0/3000)	34.7/3000 (46.5/3000)
	DIN6271-NA kW/rpm (ps/rpm)	16.2/3000 (22.0/3000)	21.3/3000 (29.0/3000)	20.2/3000 (27.5/3000)	26.8/3000 (36.5/3000)
	DIN6271-NB kW/rpm (ps/rpm)	17.6/3000 (24.0/3000)	23.5/3000 (32.0/3000)	22.4/3000 (30.5/3000)	29.8/3000 (40.5/3000)
	DIN70020 kW/rpm (ps/rpm)	19.5/3000 (26.5/3000)	26.1/3000 (35.5/3000)	24.6/3000 (33.5/3000)	32.7/3000 (44.5/3000)
Maximum bare speed rpm		3200			
Minimum idling speed rpm		850 to 950			
Maximum torque N·m/rpm kgf·m/rpm ft·lbs/rpm		68.3/2000 6.96/2000 50.3/2000	91.5/2000 9.33/2000 67.5/2000	86.0/2000 8.77/2000 63.4/2000	114.7/2000 11.7/2000 84.6/2000
Combustion chamber		Spherical type (E-TVCE)			
Fuel injection pump		Bosch MD type mini pump			
Governor		Centrifugal mechanical governor			
Direction of rotation		Counter-clockwise (viewed from flywheel side)			
Injection nozzle		Mini nozzle (DNOPD)			
Injection timing	Without timer	0.31 to 0.35 rad. (18 to 20°) before T.D.C.			
	With timer	0.14 to 0.17 rad. (8 to 10°) before T.D.C.	0.21 to 0.24 rad. (12 to 14°) before T.D.C.	0.14 to 0.17 rad. (8 to 10°) before T.D.C.	
Firing order		1-2-3	1-3-4-2	1-2-3	1-3-4-2
Injection pressure		13.73 MPa (140 kgf/cm ² , 1991 psi)			
Compression ratio		22 : 1		22.5 : 1	
Lubricating system		Forced lubrication by pump			
Oil pressure indicating		Electrical type switch			
Lubricating filter		Full flow paper filter (cartridge type)			
Cooling system		Pressurized radiator, forced circulation with water pump (not included in the basic engine)			
Starting system		Electric starting with starter			
		12 V, 1.0 kW	12 V, 1.2 kW	12 V, 1.0 kW	12 V, 1.2 kW
Starting support device		By glow plug in combustion chamber			
Battery		12 V, 65 AH, equivalent	12 V, 70 AH, equivalent	12 V, 65 AH, equivalent	12 V, 56 AH
Dynamo for charging		12 V, 360 W			
Fuel		Diesel fuel No. 2-D (ASTM D975)			
Lubricating oil		MIL-L-46152, MIL-L-2104C, quality better than CD class (API)		Quality better than CE class (API)	
Lubricating oil capacity	125 mm (4.92 in.)	5.1 L (5.39 U.S.qts., 4.49 Imp.qts.)	6.0 L (6.34 U.S.qts., 5.28 Imp.qts.)	5.1 L (5.39 U.S.qts., 4.49 Imp.qts.)	6.7 L (7.08 U.S.qts., 5.90 Imp.qts.)
	101 mm (3.97 in.)	4.0 L (4.23 U.S.qts., 3.52 Imp.qts.)	4.7 L (4.97 U.S.qts., 4.14 Imp.qts.)	4.0 L (4.23 U.S.qts., 3.52 Imp.qts.)	-
Weight (Dry) kg (lbs)		93.0 (205.0)	110.0 (242.5)	97.0 (213.8)	114.0 (251.3)

01640Z00100

MECHANISM

CONTENTS

■	FEATURE	M-1
■	ENGINE BODY	M-3
	[1] CYLINDER BLOCK.....	M-3
	[2] CYLINDER HEAD.....	M-3
	[3] CRANKSHAFT.....	M-5
	[4] PISTON AND PISTON RINGS	M-5
	[5] CONNECTING ROD.....	M-7
	[6] ROCKER ARM.....	M-7
	[7] CAMSHAFT	M-7
	[8] FUEL CAMSHAFT	M-9
	[9] FLYWHEEL.....	M-9
■	LUBRICATING SYSTEM.....	M-11
	[1] GENERAL.....	M-11
	[2] OIL PUMP.....	M-13
	[3] RELIEF VALVE.....	M-13
	[4] OIL FILTER CARTRIDGE.....	M-15
	[5] OIL PRESSURE SWITCH	M-15
■	COOLING SYSTEM.....	M-17
	[1] GENERAL.....	M-17
	[2] WATER PUMP.....	M-17
	[3] THERMOSTAT	M-19
	[4] RADIATOR (not included in the basic engine).....	M-19
	[5] RADIATOR CAP	M-21
■	INTAKE / EXHAUST SYSTEM	M-23
	[1] AIR CLEANER (not included in the basic engine)	M-23
	[2] MUFFLER (not included in the basic engine)	M-23
■	FUEL SYSTEM.....	M-25
	[1] GENERAL.....	M-25
	[2] INJECTION PUMP.....	M-25
	(1) Pump Element.....	M-27
	(2) Delivery Valve	M-27
	(3) Dumping Valve.....	M-29
	(4) Injection Control	M-29
	[3] INJECTION NOZZLE.....	M-31
	[4] FUEL FILTER (not included in the basic model).....	M-31
	[5] GOVERNOR.....	M-33
	[6] AUTOMATIC ADVANCE TIMER (not included in the basic model)	M-37
■	ELECTRICAL SYSTEM.....	M-41
	[1] CHARGING SYSTEM.....	M-41
	(1) Alternator.....	M-41
	(2) IC Regulator	M-41
■	TURBO CHARGER SYSTEM.....	M-43
	(1) Mechanism.....	M-45
	(2) Turbine	M-47
	(3) Compressor.....	M-47
	(4) Bearing.....	M-49
	(5) Seals (Piston Rings).....	M-51

F FEATURE

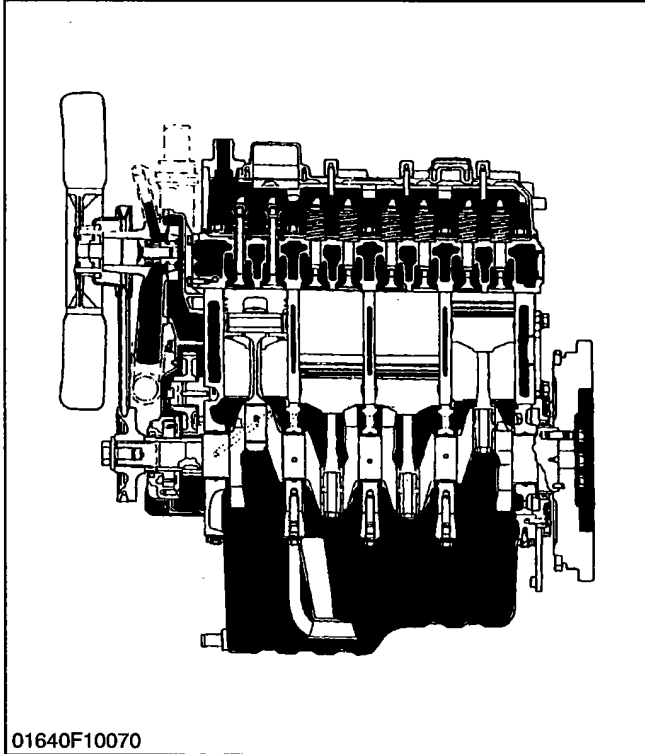

01640F10070

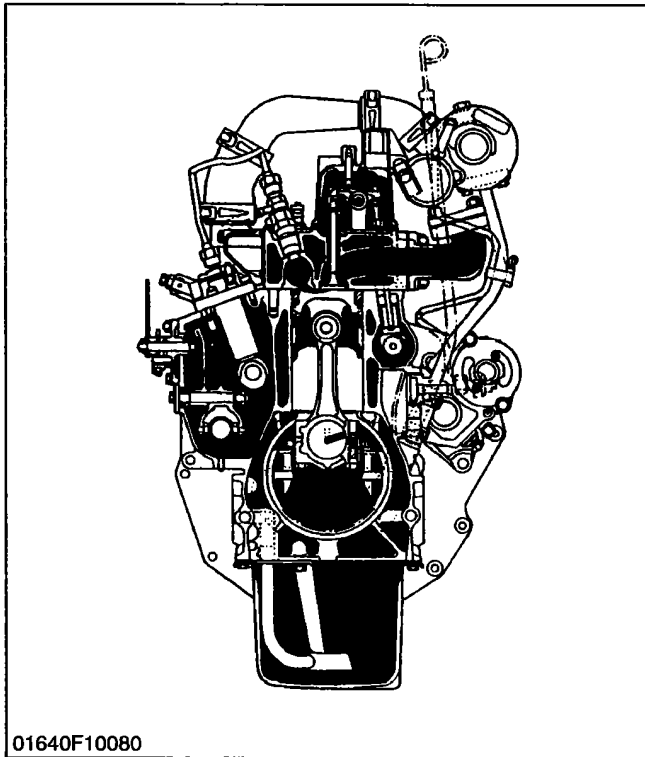

01640F10080

The 05 SERIES ENGINE are vertical, water-cooled, 4 cycle diesel engines.

They are incorporated KUBOTA's foremost technologies. With KUBOTA's E-TVCS (Three Vortex Combustion System), well-known Bosch MD type injection pump and the well-balanced designs, they give greater power, low fuel consumption, little vibration and quiet operation.

■ NOTE

- Since January 1994, E-TVCS has been used for the combustion chamber of our products instead of traditional N-TVCS.

E-TVCS was developed with an eye toward clean exhaust gas which is more environmentally freindly.

The combustion chamber models mentioned hereinafter refers to E-TVCS.

Model of combustion chamber :

N-TVCS

(Engine Serial Number ; 489290 or lower)

E-TVCS

(Engine Serial Number ; 489291 or higher)

11900M10011

1 ENGINE BODY

[1] CYLINDER BLOCK

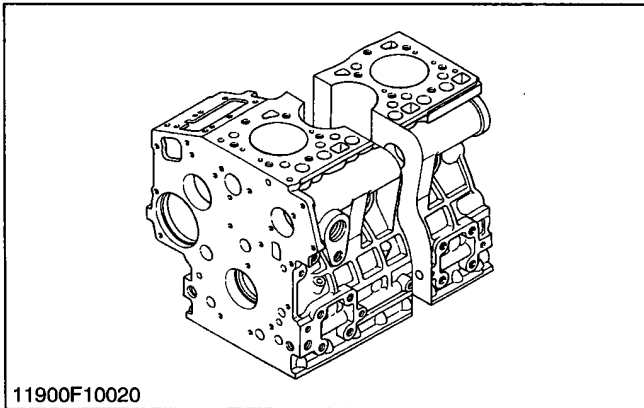

The engine has a high durability tunnel-type cylinder block in which the crank bearing component is a constructed body.

Furthermore, liner less type, allow effective cooling, less distortion, and greater wear-resistance.

The noise level is reduced to a minimum because each cylinder has its own chamber.

11900M10020

[2] CYLINDER HEAD

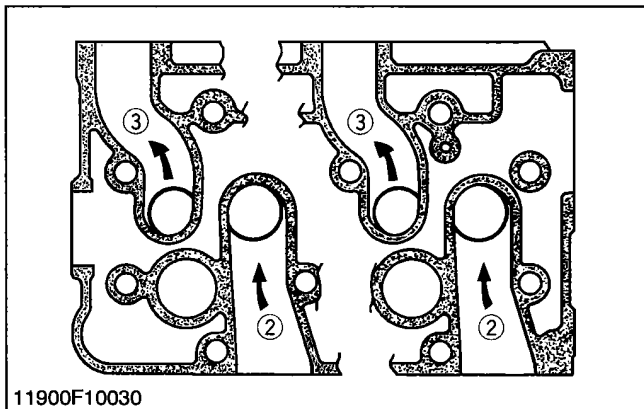

The cross-flow type intake / exhaust ports in this engine have their openings at both sides of the cylinder head. Because overlaps of intake / exhaust ports are smaller than in ports of other types which have openings on one side, the suction air can be protected from being heated and expanded by heated exhaust air. The cool, high density suction air has high volume efficiency and raises the power of the engine. Furthermore, distortion of the cylinder head by heated exhaust gas is reduced because intake ports are arranged alternately.

The combustion chamber is of KUBOTA's exclusive E-TVCS combustion chamber type. Suction air is whirled to be mixed effectively with fuel, prompting combustion and reducing fuel consumption.

In the combustion chamber are installed throttle type injection nozzle and rapid heating sheathed type glow plug. This glow plug assures easier than ever engine starts even at -15°C (5°F).

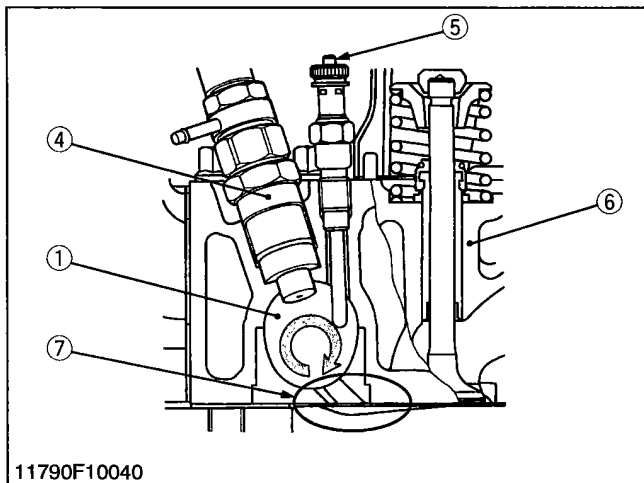

- | | |
|------------------------|-----------------------------------|
| (1) Combustion Chamber | (7) Depression |
| (2) Intake Port | (8) Compressed Air |
| (3) Exhaust Port | (A) Connect to Combustion Chamber |
| (4) Nozzle Assembly | |
| (5) Glow Plug | |
| (6) Cylinder Head | |

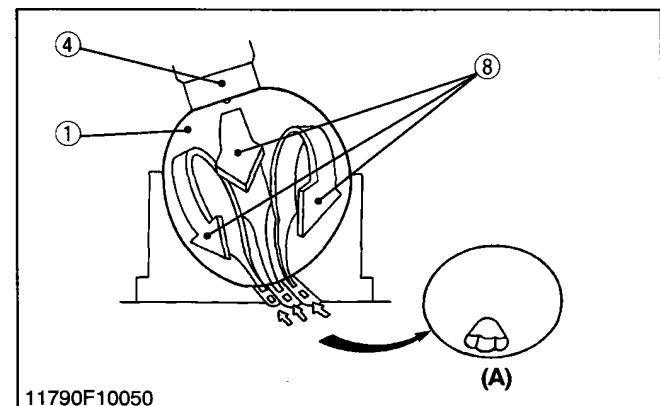

11900M10031

[3] CRANKSHAFT

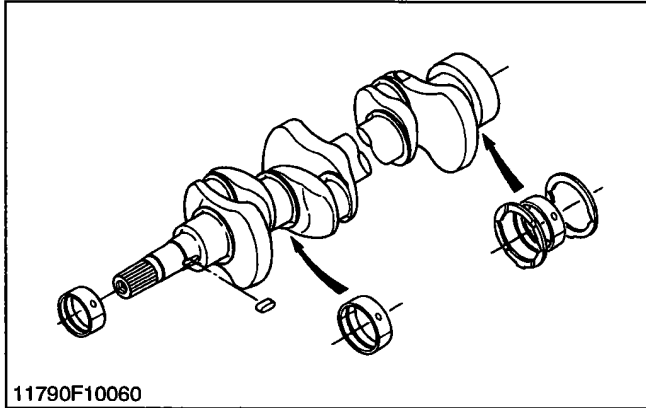

The crankshaft with the connecting rod converts the reciprocating motion of the piston into the rotating motion.

The crankshaft is made of tough special alloy steel, and the journals, pins and oil seal sliding portions are induction hardened to increase the hardness for higher wear resistance.

The front journal is supported by a solid type bearing, the intermediate journal by a split type, and the rear journal by a split type with thrust bearings.

The crankshaft is provided with an oil gallery, through which engine oil is fed to the crankpin portion, and lubricates it.

11790M10040

[4] PISTON AND PISTON RINGS

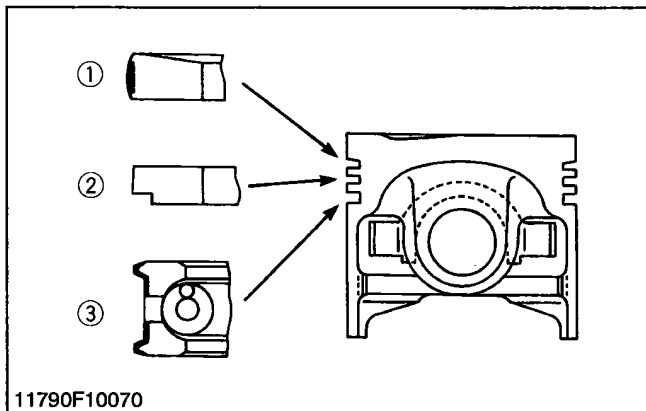

The piston has a slightly oval shape when cold (in consideration of thermal expansion) and a concave head.

Three rings are installed in grooves in the piston.

The top ring (1) is a keystone type, which can stand against heavy loads, and the barrel face on the ring fits well to the cylinder wall.

The second ring (2) is an undercut type, which effectively prevents the oil from being carried up.

The oil ring (3) has chamfered contact faces and an expander ring, which increase the pressure of the oil ring against the cylinder wall.

Several grooves are cut on the top land to help heat dissipate and to prevent scuffing.

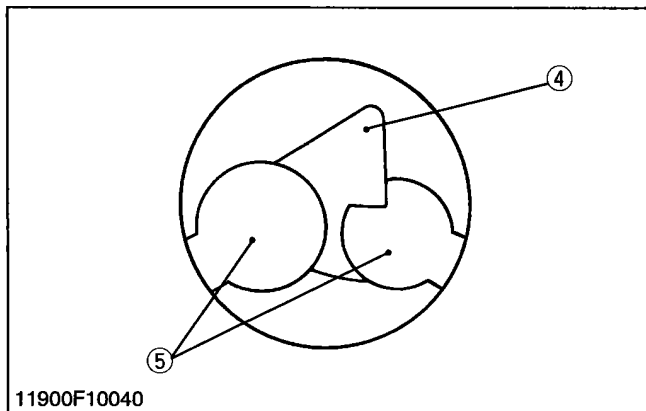

- (1) Top Ring
- (2) Second Ring
- (3) Oil Ring
- (4) Depression
- (5) Valve Recess

11900M10041

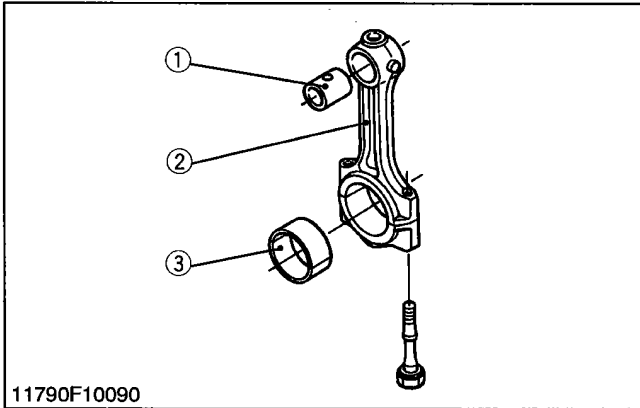
[5] CONNECTING ROD

11790F10090

The connecting rod (2) is used to connect the piston with the crankshaft.

The big end of the connecting rod has a crankpin bearing (3) (split type) and the small end has a small end bushing (1) (solid type).

- | | |
|-----------------------|----------------------|
| (1) Small End Bushing | (3) Crankpin Bearing |
| (2) Connecting Rod | |

11790M10060

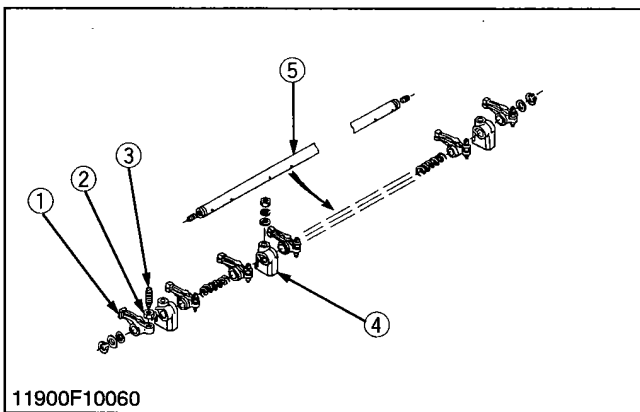
[6] ROCKER ARM

11900F10060

The rocker arm assembly includes the rocker arms (1), rocker arm brackets (4) and rocker arm shaft (5), and converts the reciprocating movement of the push rods to an open / close movement of the intake and exhaust valves.

Lubricating oil pressurized through the bracket to the rocker arm shaft, which serves as a fulcrum so that the rocker arm and the entire system are lubricated sufficiently.

- | | |
|---------------------|------------------------|
| (1) Rocker Arm | (4) Rocker Arm Bracket |
| (2) Lock Nut | (5) Rocker Arm Shaft |
| (3) Adjusting Screw | |

11900M10070

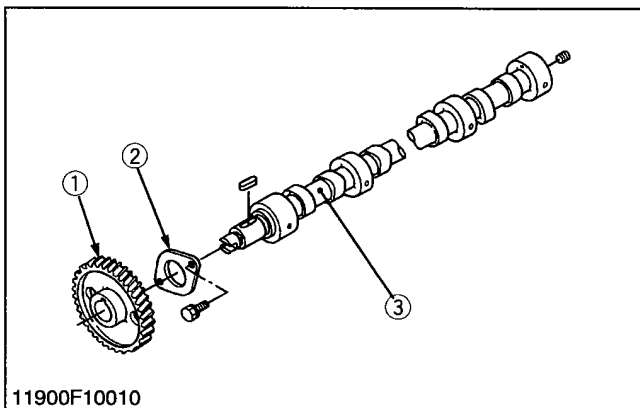
[7] CAMSHAFT

11900F10010

The camshaft (3) is made of special cast iron, and the journal and cam sections are chilled to resist wear.

The journal sections are force-lubricated.

- | | |
|----------------------|--------------|
| (1) Cam Gear | (3) Camshaft |
| (2) Camshaft Stopper | |

11900M10050

[8] FUEL CAMSHAFT

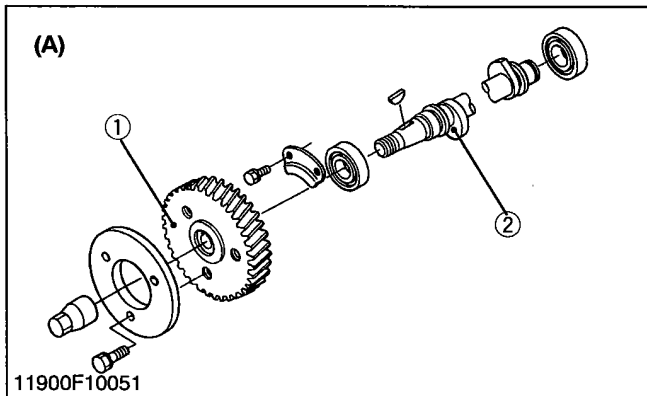

The fuel camshaft (2) controls the reciprocating movement of the injection pump.

The fuel camshaft is made of carbon steel and the cam sections are quenched and tempered to provide greater wear resistance.

- (1) Injection Pump Gear
 - (2) Fuel Camshaft
 - (3) Automatic Advance Timer (not included in the basic model)
- (A) Without Timer
 - (B) With Timer

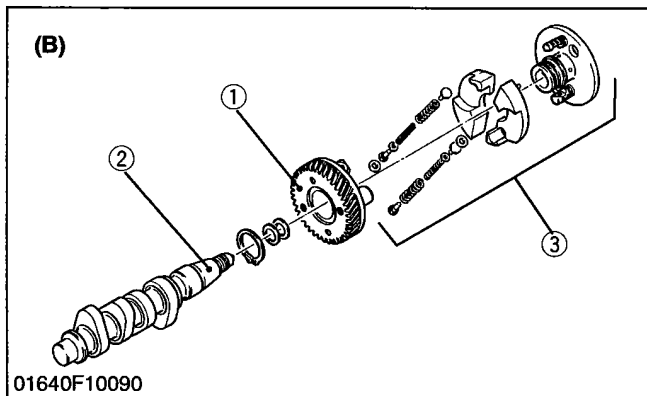

11900M10061

[9] FLYWHEEL

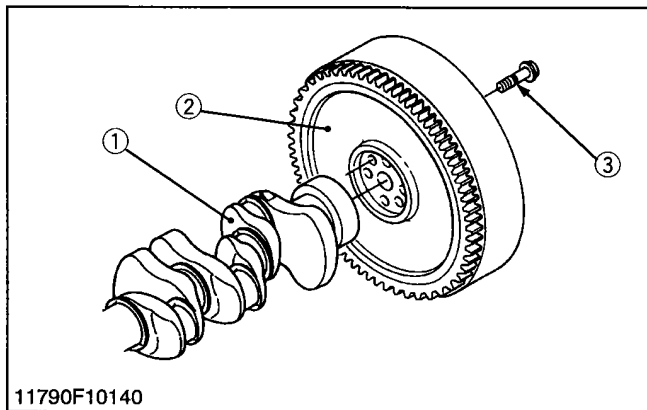

The flywheel stores the rotating force in the combustion stroke as inertial energy, reduces crankshaft rotating speed fluctuation and maintains the smooth rotating conditions.

The flywheel periphery is inscribed with the marks showing fuel injection timing angle lines and top dead center mark **TC**.

The flywheel has gear teeth around its outer rim, which mesh with the drive pinion of the starter.

- (1) Crankshaft
- (2) Flywheel
- (3) Flywheel Screw

11900M10081

2 LUBRICATING SYSTEM

[1] GENERAL

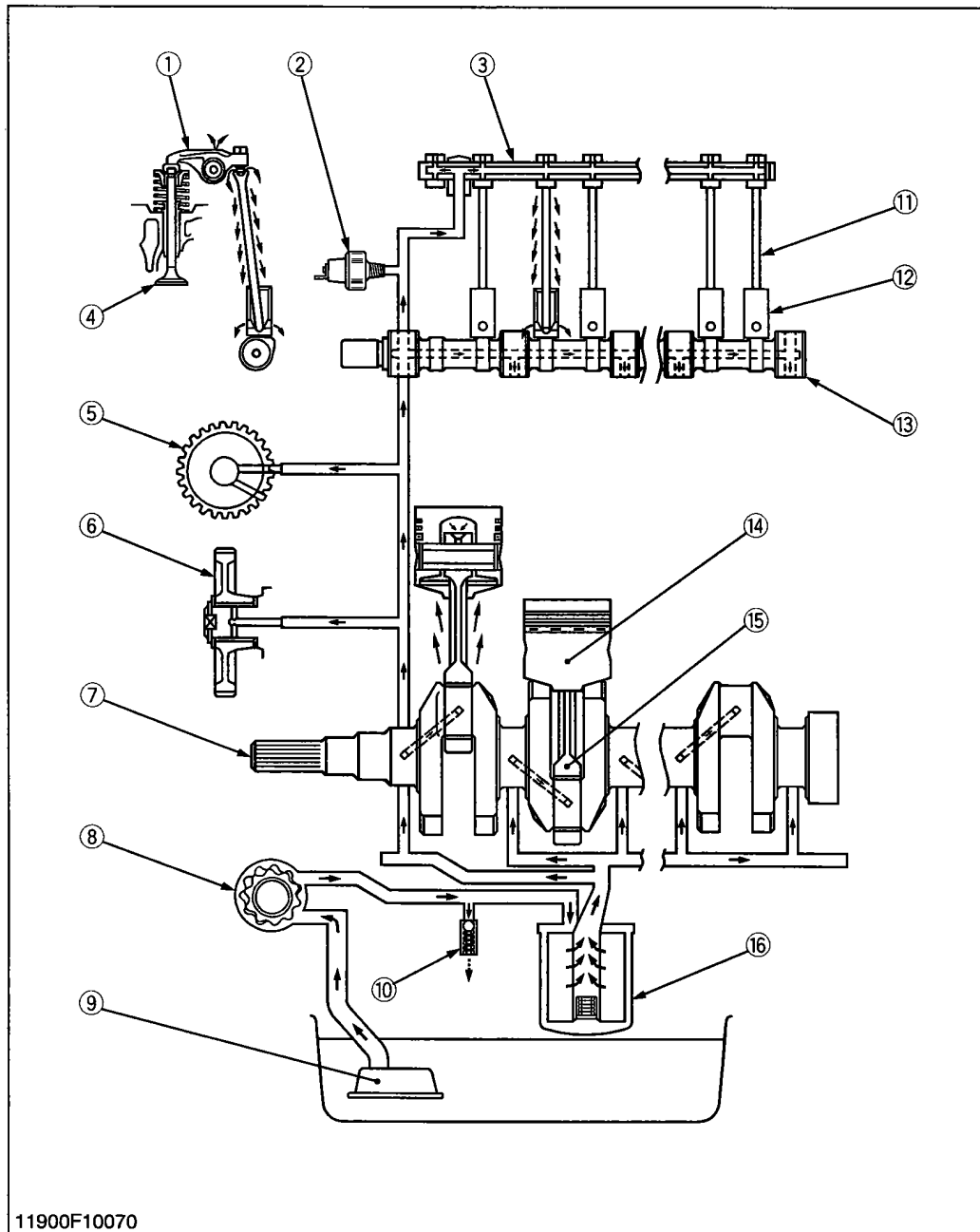

- (1) Rocker Arm
- (2) Oil Pressure Switch
- (3) Rocker Arm Shaft
- (4) Valve
- (5) Governor Shaft
- (6) Idle Gear
- (7) Crankshaft
- (8) Oil Pump
- (9) Oil Strainer
- (10) Relief Valve
- (11) Push Rod
- (12) Tappet
- (13) Camshaft
- (14) Piston
- (15) Connecting Rod
- (16) Oil Filter Cartridge

11900F10070

This engine's lubricating system consists of oil strainer (9), oil pump (8), relief valve (10), oil filter cartridge (16) and oil pressure switch (2).

The oil pump sucks lubricating oil from the oil pan through the oil strainer and the oil flows down to the filter cartridge, where it is further filtered. Then the oil is forced to crankshaft (7), connecting rods (15), idle gear

(6), governor shaft (5), camshaft (13) and rocker arm shaft (3) to lubricate each part.

Some part of oil, splashed by the crankshaft or leaking and dropping from gaps of each part, lubricates these parts : pistons (14), cylinders, small ends of connecting rods, tappets (12), push rods (11), inlet and exhaust valves (4) and timing gears.

11900M10090

[2] OIL PUMP

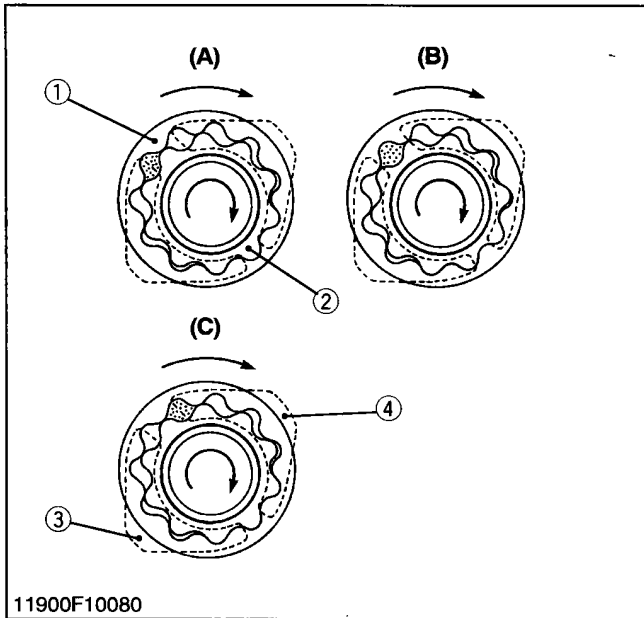

The oil pump in this engine is a trochoid pump. Inside the pump body, the 10 lobe inner rotor (2) is eccentrically engaged with the 11 lobe outer rotor (1). The inner rotor is driven by the crankshaft, which in turn rotate the outer rotor.

When the inner rotor rotates, the outer rotor also rotates in the same direction. The two rotors have differences in lobe number and center, which generates space between lobes as shown in the figure.

At position (A), there is little space between lobes in the inlet port. As the rotor rotates towards position, the space between the lobes becomes larger, creating a negative pressure which sucks in oil.

Outside the inlet port, as shown in position (B), the space between the lobes becomes gradually smaller, and oil pressure increases. At position (C), oil is discharged from the outlet port.

- (1) Outer Rotor
- (2) Inner Rotor
- (3) Inlet Port
- (4) Outlet Port

11900M10101

[3] RELIEF VALVE

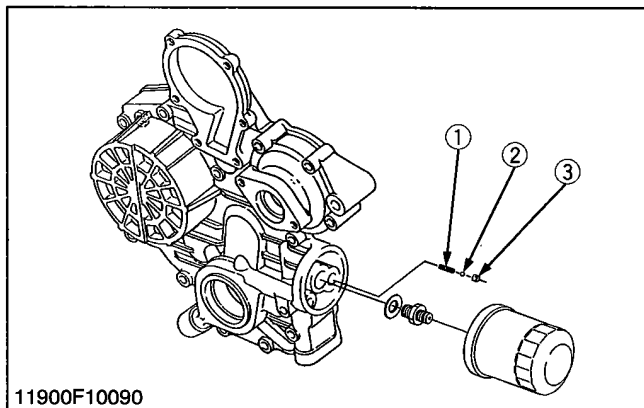

The relief valve prevents the damage of the lubricating system due to high oil pressure. This relief valve is a ball type direct acting relief valve, and is best suited for low pressures.

When oil pressure exceeds the upper limit, the ball (2) is pushed back by the pressure oil and the oil escapes.

- (1) Spring
- (2) Steel Ball
- (3) Valve Seat

11900M10111

[4] OIL FILTER CARTRIDGE

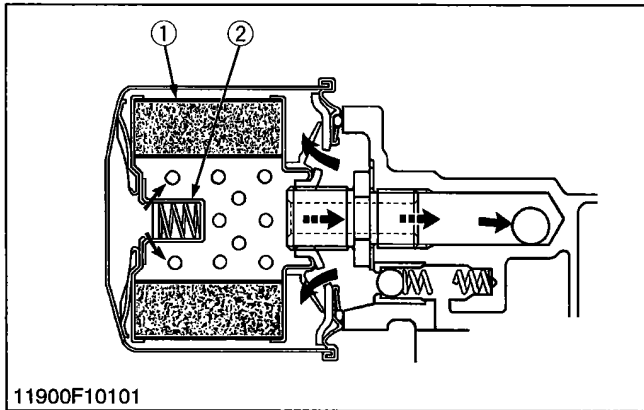
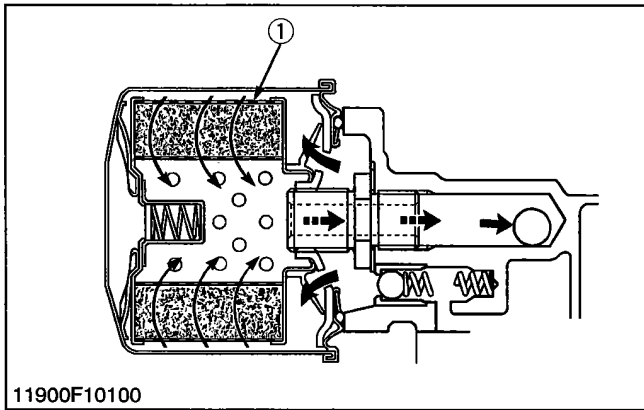

Impurities in engine oil can cause to wear and seize components as well as impairing the physical and chemical properties of the oil itself. Impurities contained in force-fed engine oil are absorbed on the filter paper for removal as they pass through the filter element (1).

When the filter element is clogged and the oil pressure in inlet line builds up by 98 kPa (1.0 kgf/cm², 14 psi) more than the outlet line, the bypass valve (2) opens and the oil flows from inlet to outlet bypassing the filter element.

- (1) Filter Element
- (2) Bypass Valve

11900M10120

[5] OIL PRESSURE SWITCH

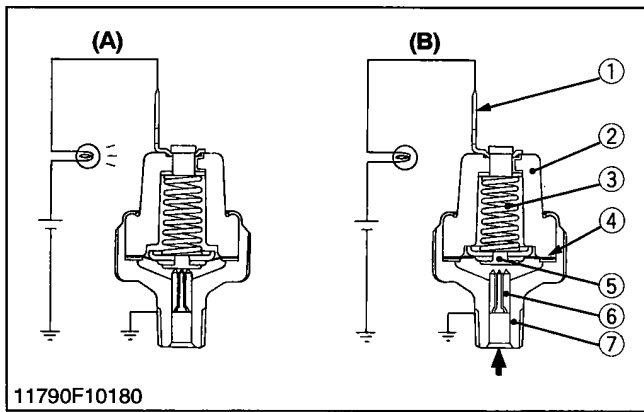

The oil pressure switch is mounted on the cylinder block, to warn the operator that the lubricating oil pressure is poor.

If the oil pressure falls below 49 kPa (0.5 kgf/cm², 7 psi), the oil warning lamp will light up, warning the operator. In this case, stop the engine immediately and check the cause of pressure drop.

- (1) Terminal
 - (2) Insulator
 - (3) Spring
 - (4) Rubber Gasket
 - (5) Contact Rivet
 - (6) Contact
 - (7) Oil Switch Body
- (A) At Oil Pressures of 49 kPa (0.5 kgf/cm², 7 psi) or Less
 - (B) At Proper Oil Pressure

11790M10152

3 COOLING SYSTEM

[1] GENERAL

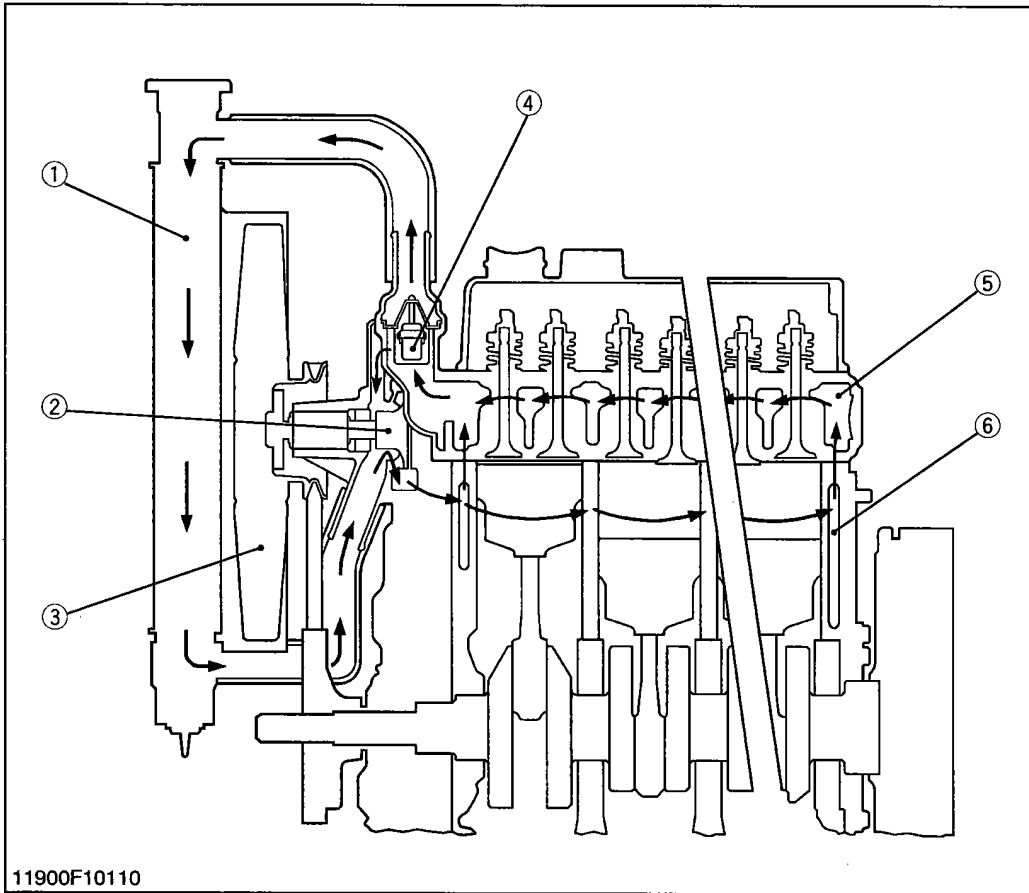

- (1) Radiator
- (2) Water Pump
- (3) Suction Fan
- (4) Thermostat
- (5) Cylinder Head
- (6) Cylinder Block

The cooling system consists of a radiator (1) (not included in the basic engine), centrifugal water pump (2), suction fan (3) and thermostat (4).

The water is cooled through the radiator core, and the fan set behind the radiator pulls cooling air through the core to improve cooling.

The water pump sucks the cooled water, forces it into the cylinder block and draws out the hot water. Then the

cooling is repeated. Furthermore, to control temperature of water, a thermostat is provided in the system. When the thermostat opens, the water moves directly to radiator, but when it closes, the water moves toward the water pump through the bypass between thermostat and water pump. The opening temperature of thermostat is approx. 71 °C (160 °F).

11900M10131

[2] WATER PUMP

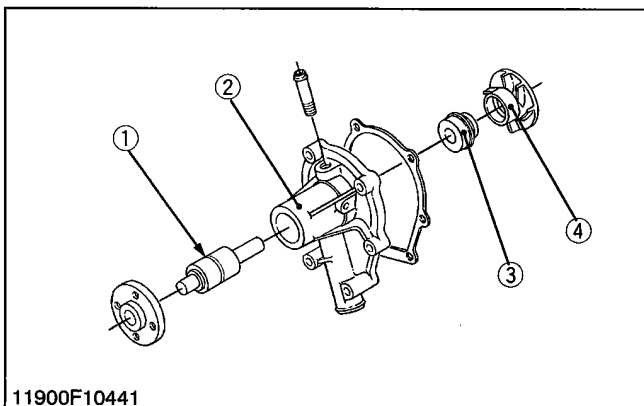

The water pump is driven by the crankshaft via a V belt. Water cooled in the radiator is sucked into the water pump from its lower portion and is sent from the center of the water pump impeller (4) radially outward into the water jacket in the crankcase.

- (1) Bearing Unit
- (2) Water Pump Body
- (3) Mechanical Seal
- (4) Water Pump Impeller

11900M10141

[3] THERMOSTAT

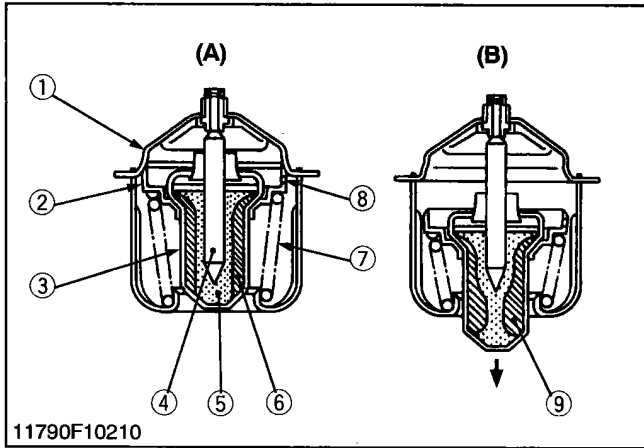

The thermostat maintains the cooling water at correct temperature. KUBOTA's engine uses a wax pellet type thermostat. Wax is enclosed in the pellet. The wax is solid at low temperatures, but turns liquid at high temperatures, expands and opens the valve.

(A) At low temperature (lower than 71 °C, 160 °F)

As the thermostat is closed, cooling water circulates in the engine through the water return pipe without running to the radiator.

Air in the water jacket escapes to the radiator side through leak hole (8) of the thermostat.

(B) At high temperature (higher than 71 °C, 160 °F)

When the temperature of cooling water exceeds 71 °C (160 °F), wax in the pellet turns liquid and expands. Because the spindle (4) is fixed, the pellet (3) is lowered, the valve (2) is separated from the seat (1), and then cooling water is sent to the radiator.

- | | |
|----------------------|------------------|
| (1) Seat | (6) Wax (Solid) |
| (2) Valve | (7) Spring |
| (3) Pellet | (8) Leak Hole |
| (4) Spindle | (9) Wax (Liquid) |
| (5) Synthetic Rubber | |

11790M10182

[4] RADIATOR (not included in the basic engine)

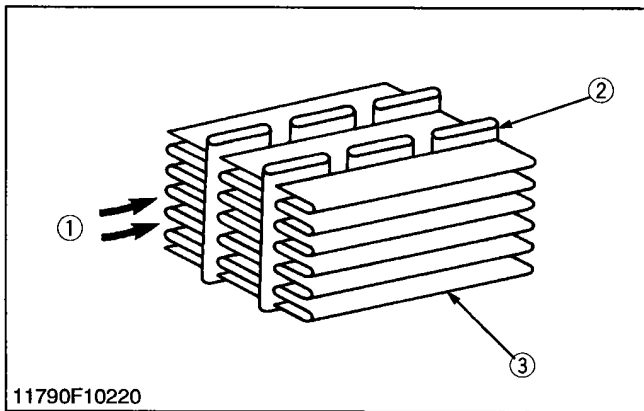

The radiator core consists of water carrying tubes (2) and fins (3) at a right angle to the tubes (2). Heat of hot water in the tubes is radiated from the tube walls and fins. KUBOTA's engine uses corrugated fin type core which has a light weight and high heat transfer rate. Clogging is minimized by the louverless corrugated fins.

- | | |
|-----------------|---------|
| (1) Cooling Air | (3) Fin |
| (2) Tube | |

11790M10191

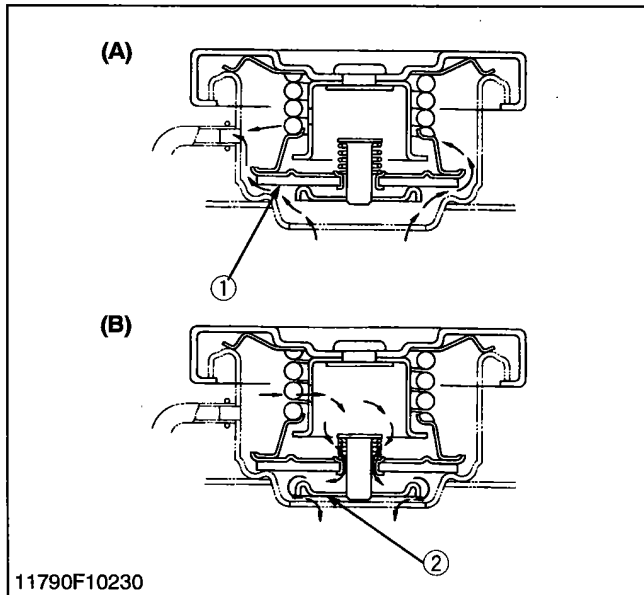
[5] RADIATOR CAP

The radiator cap is for sustaining the internal pressure of the cooling system at the specified level 88 kPa (0.9 kgf/cm², 13 psi) when the engine is in operation. The cap consists of a pressure valve (1) a vacuum valve (2), valve springs, gasket, etc.

Cooling water is pressurized by thermal expansion of steam, and as its boiling temperature rises, generation of air bubbles will be suppressed. (Air bubbles in cooling water lowers the cooling effect.)

- (1) Pressure Valve
- (2) Vacuum Valve

- (A) When radiator internal pressure is high
- (B) When radiator internal pressure is negative

11790M10201

4 INTAKE / EXHAUST SYSTEM

[1] AIR CLEANER (not included in the basic engine)

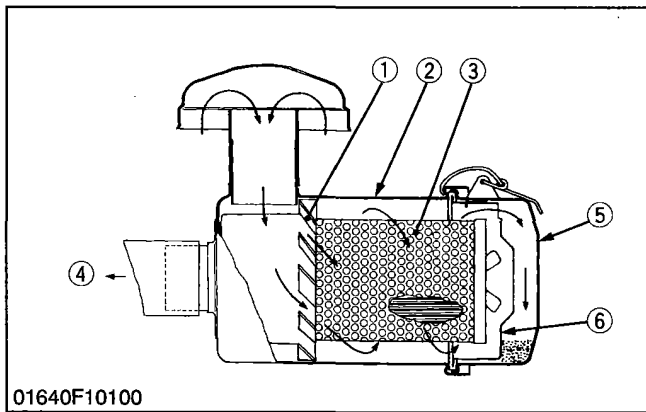

The air cleaner is a dry-cyclone type for easy maintenance. Sucked air is caused to flow in a whirling way with fin (1). As a result, heavier dust particles circulate around the circumference and enter the holes in the baffle cover (6) and accumulate in the dust cup (5). Minute dust, while circulating in the air flow, is absorbed by the element (3) and thus prevented from entering the engine.

- | | |
|------------------------|------------------|
| (1) Fin | (4) To Cylinder |
| (2) Air Cleaner Body | (5) Dust Cup |
| (3) Air Filter Element | (6) Baffle Cover |

01640M10010

[2] MUFFLER (not included in the basic engine)

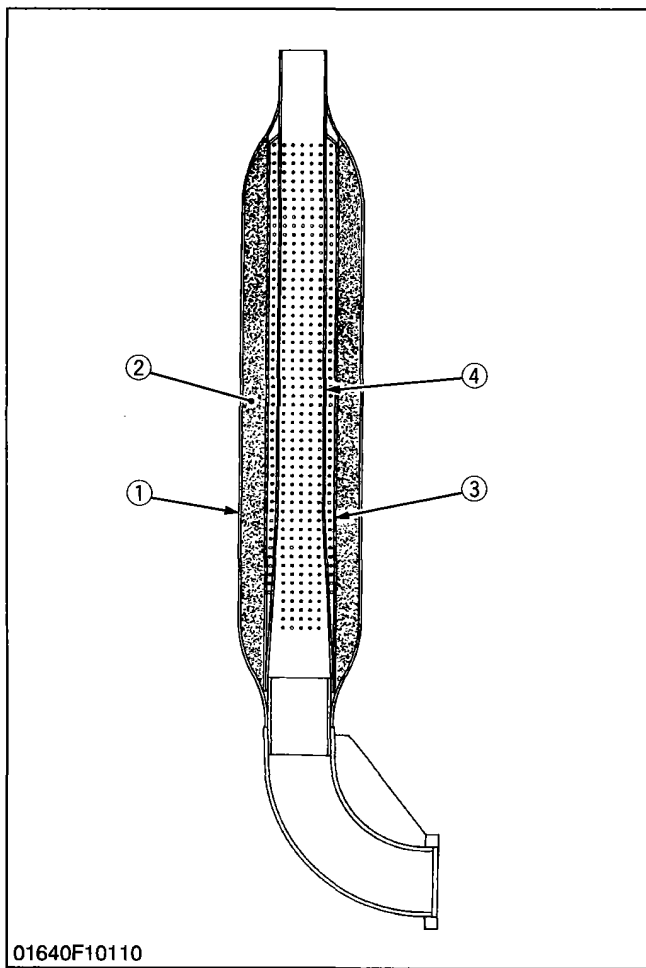

High temperature and high pressure exhaust gas is intermittently discharged by fuel combustion generating pressure waves inside the exhaust pipe which will result in noise.

The muffler is used to reduce this noise.

This muffler consists of a perforated inner tube (4) and outer tube (3), glass wool (2), main body (1), etc. The glass wool placed between the outer tube and main body, absorbs the exhaust noise of higher frequency.

- | | |
|----------------|----------------|
| (1) Main Body | (3) Outer Tube |
| (2) Glass Wool | (4) Inner Tube |

01640M10020

5 FUEL SYSTEM

[1] GENERAL

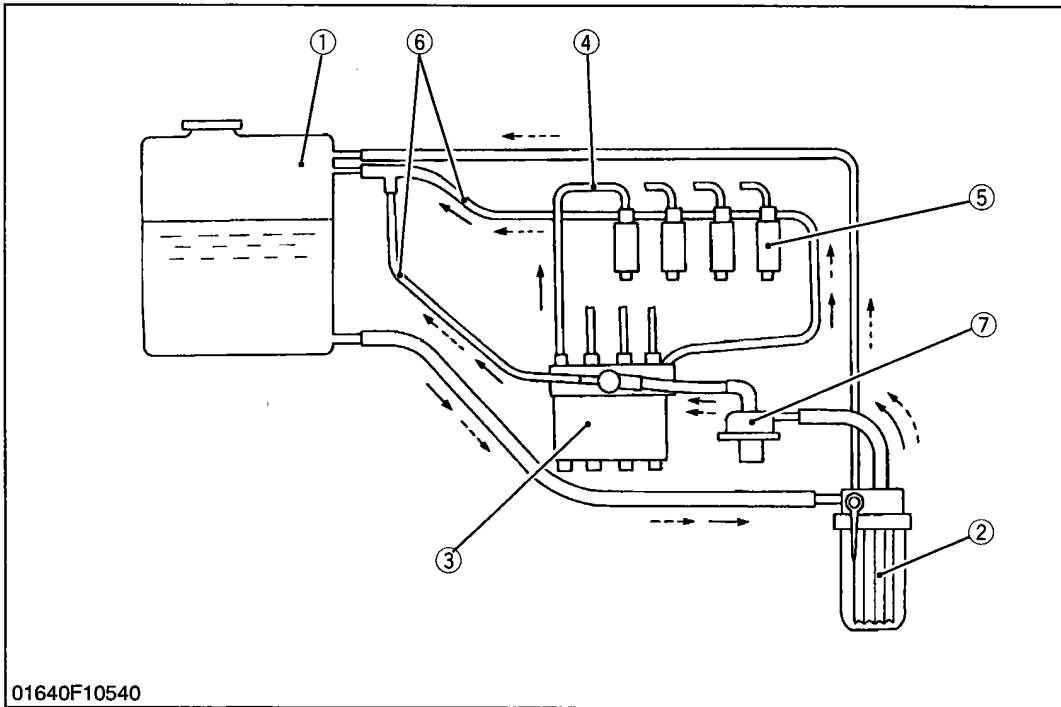

- (1) Fuel Tank
- (2) Fuel Filter
- (3) Injection Pump
- (4) Injection Pipe
- (5) Injection Nozzle
- (6) Fuel Overflow Pipe
- (7) Fuel Feed Pump

01640F10540

Fuel from the fuel tank (1) passes through the fuel filter (2), and then enters the injection pump (3) after impurities such as dirt, water, etc. are removed.

The fuel pressurized by the injection pump to the opening pressure (13.73 to 14.71 MPa, 140 to 150 kgf/cm², 1991 to 2133 psi), of the injection nozzle (5) is injected into the combustion chamber.

Part of the fuel fed to the injection nozzle (5) lubricates the moving parts of the plunger inside the nozzle, then returns to the fuel tank through the fuel overflow pipe (6) from the upper part of the nozzle holder.

11900M10151

[2] INJECTION PUMP

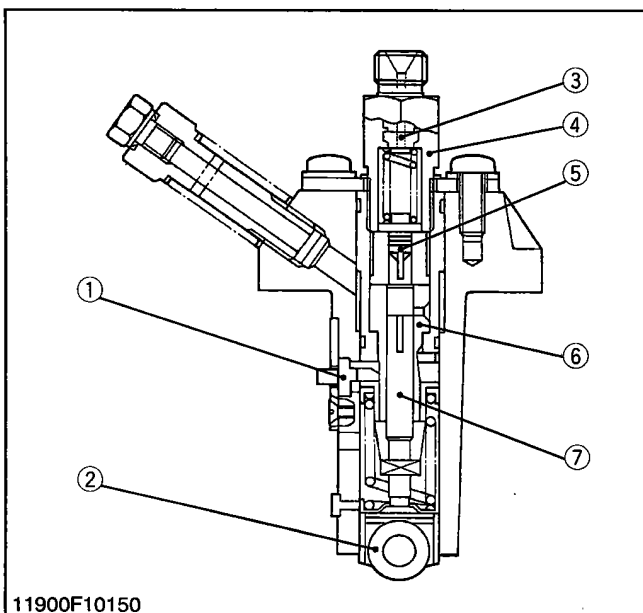

11900F10150

A Bosch MD type mini pump is used for the injection pump. It is small, lightweight and easy to handle.

The plunger (7) with a left-hand lead reciprocates via the tappet roller (2) by means of the fuel camshaft, causing the fuel to be delivered into the injection nozzle.

- (1) Control Rack
- (2) Tappet Roller
- (3) Dumping Valve
- (4) Delivery Valve Holder
- (5) Delivery Valve
- (6) Cylinder
- (7) Plunger

11900M10170

(1) Pump Element

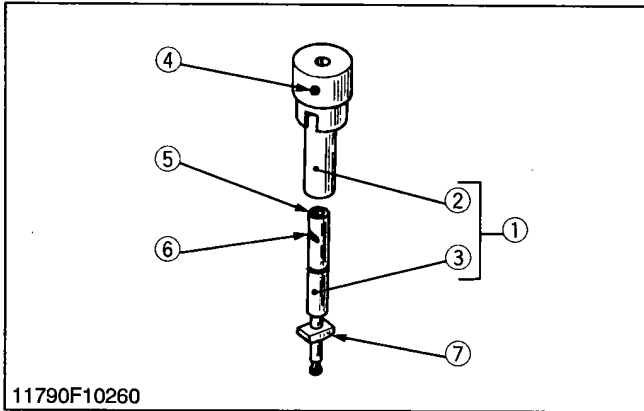

The pump element (1) is consist of the plunger (3) and cylinder (2).

The sliding surfaces are super-precision machined to maintain injection pressure at engine low speeds. Since the driving face (7) fits in the control sleeve, the plunger (3) is rotated by the movement of the control rack to increase or decrease of fuel delivery.

As described above, the plunger (3) is machined to have the slot (5) and the control groove (6).

- | | |
|------------------|--------------------|
| (1) Pump Element | (5) Slot |
| (2) Cylinder | (6) Control Groove |
| (3) Plunger | (7) Driving Face |
| (4) Feed Hole | |

11790M10231

(2) Delivery Valve

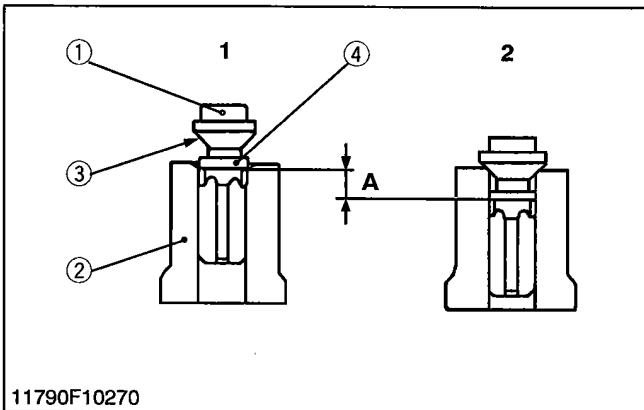

The delivery valve consists of the delivery valve (1) and delivery valve seat (2).

The delivery valve performs the following functions.

1. Reverse flow preventing function

If the fuel flow reverse from the injection nozzle side when the plunger lowers, the time lag between the next delivery start and the nozzle injection start increases. To avoid this, the delivery chamber to injection pipe interruption by delivery valve (1) prevents this reverse flow, thus keeping fuel always filled in the nozzle and pipe.

2. Suck-back function

After completing the fuel delivery, the delivery valve lowers, and the relief plunger (4) end contacts the delivery valve seat (2). The valve further lowers until its seat surface (3) seats firmly the delivery valve seat. During this time, the amount of fuel corresponding to (A) is sucked back from inside the injection pipe, the pressure inside the pipe is reduced, thus leading to an improved injection shut off and preventing after leakage dribbling.

- | | |
|-------------------------|--------------------|
| (1) Delivery Valve | (3) Seat Surface |
| (2) Delivery Valve Seat | (4) Relief Plunger |

11790M10241

(3) Dumping Valve

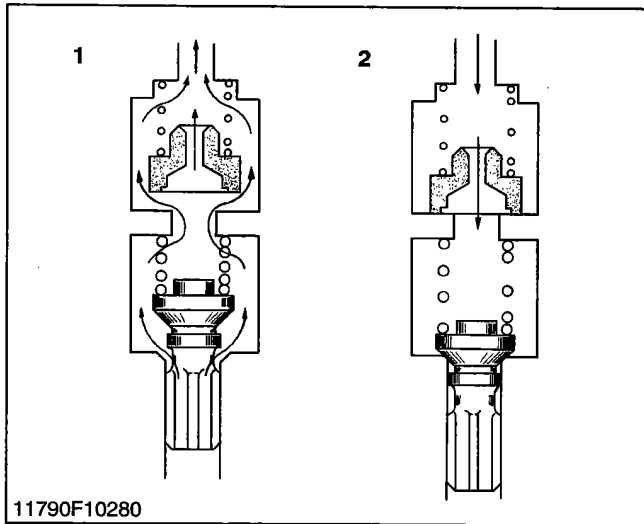

1. At fuel injection

Since dumping valve is pushed up to press the spring, fuel is pressure-fed to injection nozzle the same as without dumping valve.

2. At suck-back

At suck-back by delivery valve after fuel injection fuel returns through dumping valve orifice. Generally second injection is apt to occur by reflex pressure due to reaction of sudden pressure drop when changing into suck-back by delivery valve from high injection pressure.

As a result of preventing this second injection perfectly by dumping valve and dissolving nozzle clogging, durability of injection nozzle is improved.

11790M10251

(4) Injection Control

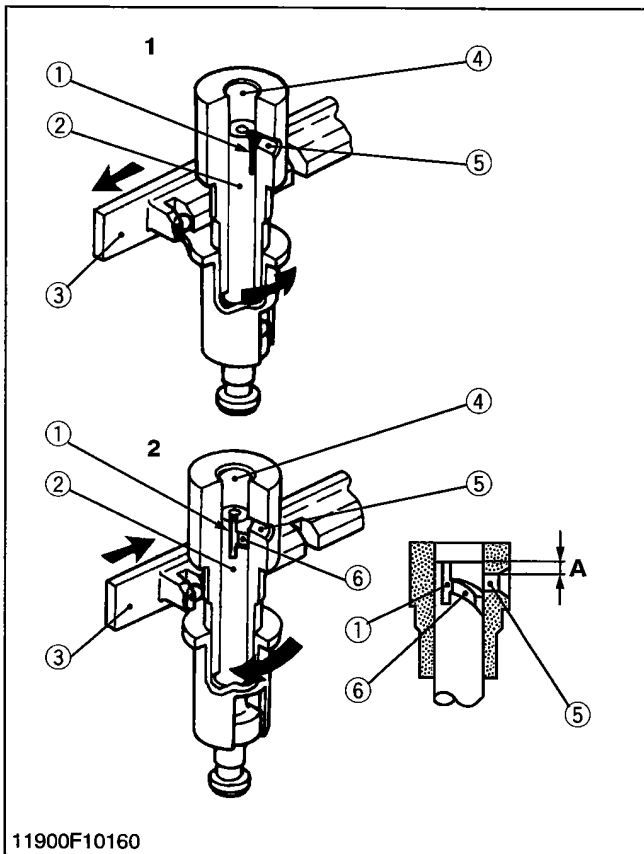

1. No fuel delivery

At the engine stop position of the control rack (3), the lengthwise slot (1) on the plunger (2) aligns with the feed hole (5). And the delivery chamber (4) is led to the feed hole during the entire stroke of the plunger.

The pressure in the delivery chamber does not build up and no fuel can be forced to the injection nozzle.

2. Fuel delivery

The plunger (2) is rotated (see figure) by the control rack (3).

When the plunger is pushed up, the feed hole (5) is closed. The pressure in the delivery chamber (4) builds up and forcefeeds the fuel to the injection nozzle until the control groove (6) meets the feed hole (5).

The amount of the fuel corresponds to the distance "A".

- | | |
|------------------|----------------------|
| (1) Slot | (4) Delivery Chamber |
| (2) Plunger | (5) Feed Hole |
| (3) Control Rack | (6) Control Groove |

11900M10181

[3] INJECTION NOZZLE

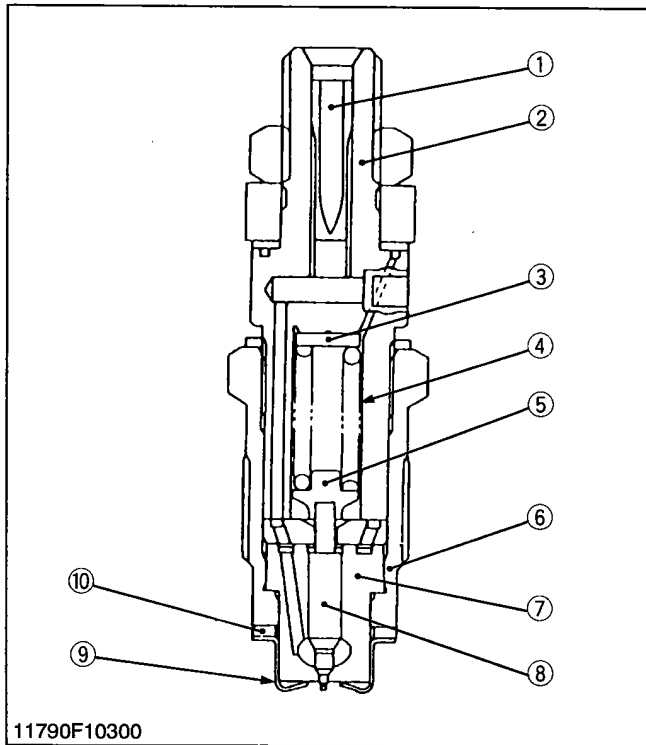

This nozzle is throttle-type. The needle valve (8) is pushed against the nozzle body (7) by the nozzle spring via the push rod (5). Fuel pressurized by the injection pump pushes the needle valve up and then is injected into the sub-combustion chamber.

Excessive flow passes from nozzle holder center through the eye joint and the fuel overflow pipe to the fuel tank.

The injection pressure is 13.73 to 14.71 MPa (140 to 150 kgf/cm², 1991 to 2133 psi), and is adjusted with adjusting washers (3).

- | | |
|------------------------|-------------------|
| (1) Bar Filter | (6) Retaining Nut |
| (2) Nozzle Holder Body | (7) Nozzle Body |
| (3) Adjusting Washer | (8) Needle Valve |
| (4) Nozzle Spring | (9) Heat Seal |
| (5) Push Rod | (10) Gasket |

11790M10272

[4] FUEL FILTER (not included in the basic model)

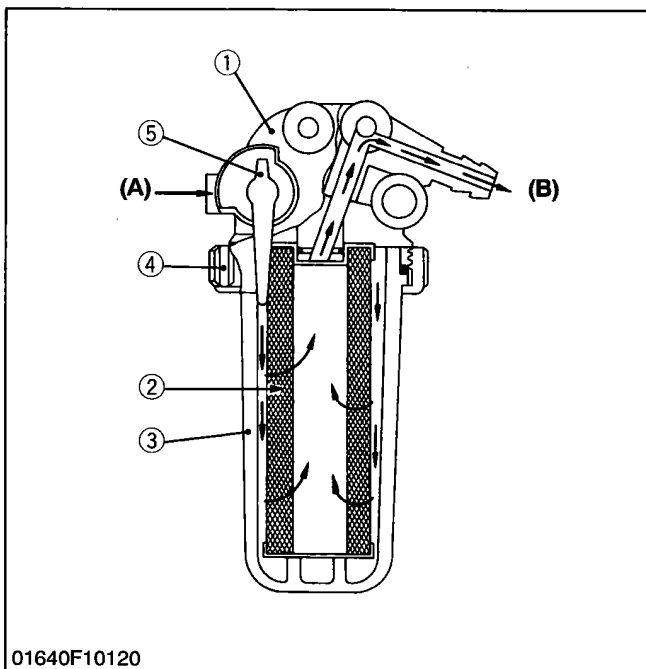

Each moving part of the injection pump and nozzle is extremely precision machined, and clearances of their sliding parts are extremely small. Fuel itself serves as lubricating oil. For this reason, it is extremely important to completely remove water and dirt contained in fuel.

This fuel filter, which uses very fine filter paper, serves to separate and filter dirt in fuel and water accumulated in the tank.

Air vent plug is fitted to the cock body. Before starting or after disassembling and reassembling, loosen this plug and bleed the air in the fuel system.

- | | |
|--------------------|------------|
| (1) Cock Body | (A) Inlet |
| (2) Filter Element | (B) Outlet |
| (3) Filter Cup | |
| (4) Retaining Ring | |
| (5) Fuel Cock | |

01640M10030

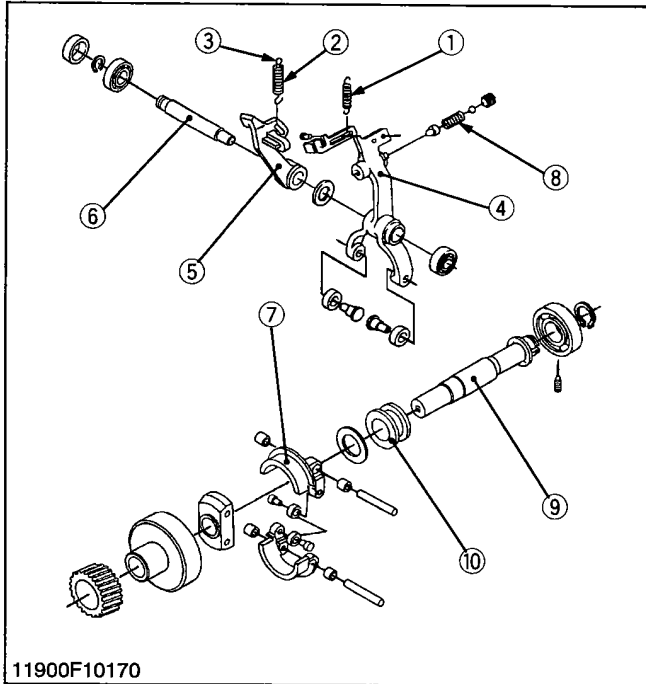
[5] GOVERNOR

This mechanism maintains engine speed at a constant level even under fluctuating loads, provides stable idling and regulates maximum engine speed by controlling the fuel injection rate.

This engine uses a mechanical governor that controls the fuel injection rate at all speed ranges (from idling to maximum speed) by utilizing the balance between the flyweight's centrifugal force and spring tension.

A governor shaft for monitoring engine speed is independent of the injection pump shaft and rotates at twice the speed of conventional types, providing better response to load fluctuation and delivering greater engine output.

- | | |
|-----------------------|----------------------|
| (1) Start Spring | (6) Fork Lever Shaft |
| (2) Governor Spring 1 | (7) Flyweight |
| (3) Governor Spring 2 | (8) Torque Spring |
| (4) Fork Lever 1 | (9) Governor Shaft |
| (5) Fork Lever 2 | (10) Governor Sleeve |

11900M10190

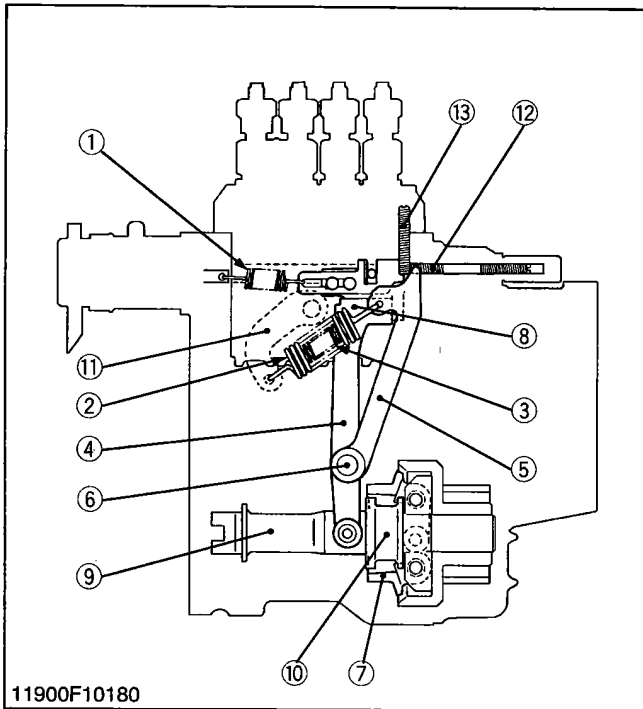

11900F10180

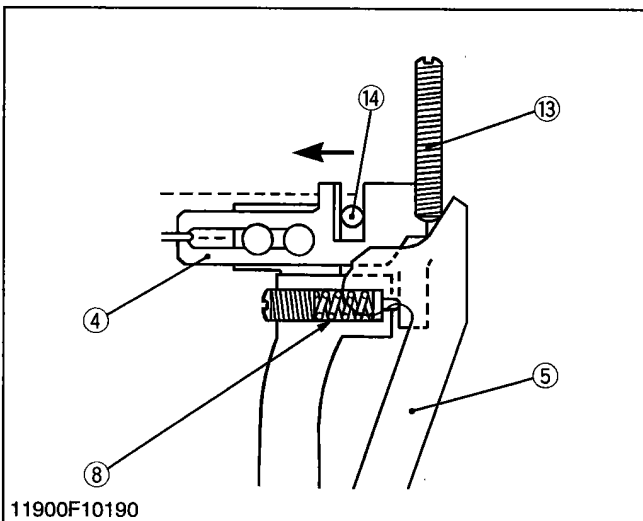

11900F10190

■ At Start

As no centrifugal force is applied to flyweight (7), low tension of start spring (1) permits control rack to move to the starting position, supplying the amount of fuel required to start the engine.

■ At Idling

Setting speed control lever (11) to the idling position during engine rotation permits the low tension of governor spring 2 (3), start spring (1) and idle limit spring (12) to balance the centrifugal force of flyweight (7) without activating high tension governor spring 1 (2). In this way, the fuel injection rate can be controlled to ensure stable idling.

■ At High Speed Running with Overload

Governor spring 1 (2) and 2 (3) control the fuel injection rate. To maintain the required engine speed, fuel is supplied according to the speed control lever setting and load by balancing the tension of governor springs 1 and 2 with the centrifugal force of flyweight (7).

In addition, idle limit spring (12) provides stable engine rotation.

■ During Overload

At load increases, the engine speed decreases, reducing the flyweight's centrifugal force. Governor springs 1 (2) and 2 (3), therefore, pull fork levers 1 (4) and 2 (5), increasing the fuel injection rate and maintaining engine speed.

If engine speed decreases due to a further increase in load, fork lever 2 (5) will come in contact with the fuel limit bolt, stopping a further increase in the fuel injection rate.

Torque spring (8) incorporated in fork lever 1 (4) moves the lever in the direction of fuel injection rate increase, thereby boosting torque and providing greater engine output.

- | | |
|-----------------------|-----------------------------|
| (1) Start Spring | (8) Torque Spring |
| (2) Governor Spring 1 | (9) Governor Shaft |
| (3) Governor Spring 2 | (10) Governor Sleeve |
| (4) Fork Lever 1 | (11) Speed Control Lever |
| (5) Fork Lever 2 | (12) Idle Limit Spring |
| (6) Fork Lever Shaft | (13) Fuel Limit Adjust Bolt |
| (7) Flyweight | (14) Control Rack Pin |

11900M10200

[6] AUTOMATIC ADVANCE TIMER (not included in the basic model)

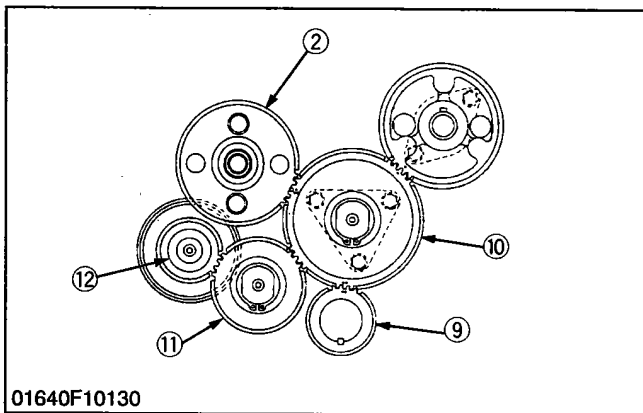
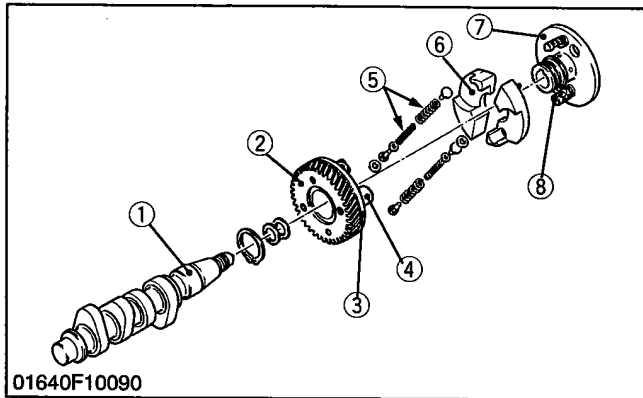

Fuel fed by the injection pump passes through the injection pipe to the injection nozzle. The time required for fuel to flow from the injection pump to the nozzle is almost constant, irrespective of enginespeed. The time required for injected fuel to ignite, burn and reach the maximum pressure is also virtually constant, irrespective of engine speed. Therefore, as engine speed increases, ignition timing is delayed, and vice versa. If fuel injection timing is fixed, it is impossible to provide optimum injection timing at each engine speed. To solve this problem, an automatic injection advance timer is used to control fuel injection timing automatically. This engine uses a mechanical timer for this purpose which utilizes the balance between the flyweight's centrifugal force (generated by engine rotation) and spring tension.

The structure of the timer is as illustrated in the figure.

Hub bolt (8) is inserted into the hole located on one side of flyweight (6). Hub (7) is secured to fuel camshaft (1) by key and nut. Driving plate (3) is bolted to injection pump gear (2). Driving bolt (4) securing driving plate (3) is in contact with the curved surface of flyweight (6). Timer spring (5) is installed between driving bolt (4) and hub bolt (8).

Therefore, torque is transmitted from the crankshaft to the fuel camshaft via the following route :

Crank gear (9) → Idle gear 1 (10) → Injection pump gear (2) → Driving plate (3) → Driving bolt (4) → Flyweight (6) → Hub bolt (8) → Hub (7) → Fuel camshaft (1)

- | | |
|-------------------------|--------------------|
| (1) Fuel Camshaft | (7) Hub |
| (2) Injection Pump Gear | (8) Hub Bolt |
| (3) Driving Plate | (9) Crank Gear |
| (4) Driving Bolt | (10) Idle Gear 1 |
| (5) Timer Spring | (11) Idle Gear 2 |
| (6) Flyweight | (12) Governor Gear |

01640M10040

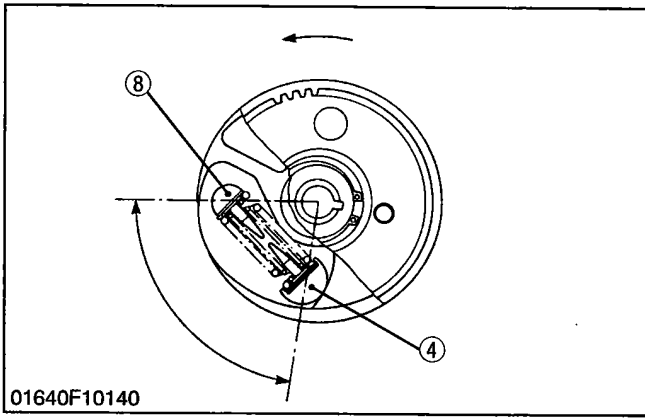

■ During low-speed travel

As the centrifugal force applied to flyweight (6) is small, spring force presses the flyweight inward, permitting driving bolt (4) to come in contact with flyweight at the position shown in the figure.

(4)Driving Bolt

(8)Hub Bolt

01640M10050

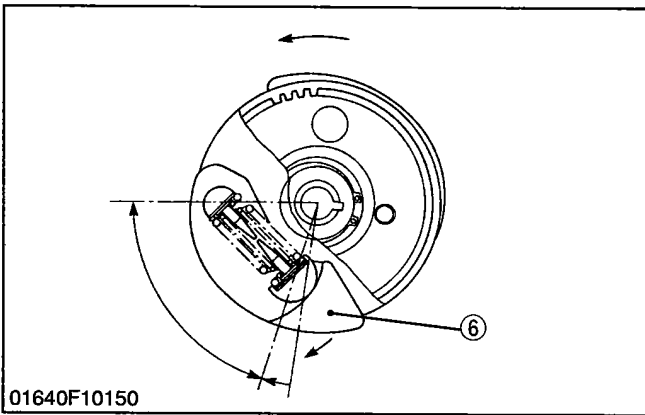

■ During medium- to high-speed travel

As engine speed increases, the centrifugal force applied to flyweight (6) increases, expanding it around hub bolt (8) in the direction of the arrow, thereby rotating the position (where driving bolt (4) is in contact with flyweight (6)) through angle θ as shown in the figure.

Therefore, since the fuel camshaft rotates from injection pump gear (2) in the rotational direction through angle θ , injection timing is advanced.

(6)Flyweight

01640M10060

Product: 1996 Kubota WSM 05 Series Diesel Engine Service Repair Workshop Manual

Full Download: <https://www.arespairmanual.com/downloads/1996-kubota-wsm-05-series-diesel-engine-service-repair-workshop-manual/>

6 ELECTRICAL SYSTEM

[1] CHARGING SYSTEM

(1) Alternator

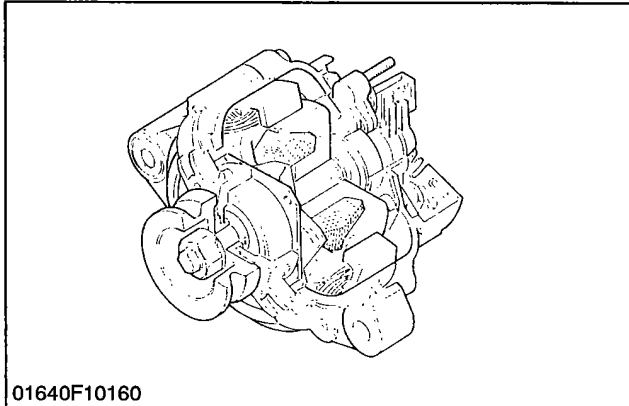

01640F10160

A compact alternator with an IC regulator is used, having the following characteristics:

- Approximately 26 % lighter and 17 % smaller than a standard alternator.
- Cooling performance and safety have been improved by combining the cooling fan with the rotor and incorporating the fan / rotor unit inside the alternator.
- IC regulator is fitted inside the alternator.
- The rectifier, IC regulator and similar components are easy to remove, making it easier to service the alternator.

01640M90010

(2) IC Regulator

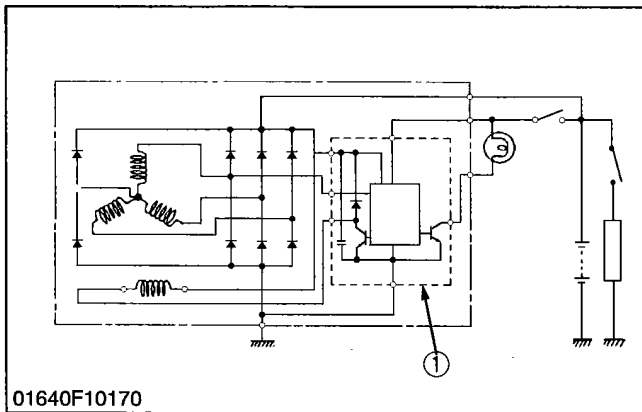

01640F10170

An IC regulator uses solid state transistors, chips or other semiconductor elements instead of the relays in a conventional regulator. Stable characteristics are achieved by cutting off the field current.

IC regulators have the following characteristics:

- The control voltage does not change over time, so the need for readjustment is eliminated. Since there are no moving parts, IC regulators are extremely durable and resistant to vibration.
- The overheat compensation characteristics ensure that the control voltage is reduced as the temperature rises, so the battery is charged at just the right level.

The internal circuitry of the IC regulator is shown in the diagram. It consists of a hybrid IC incorporating a monolithic IC. (The internal circuitry of the monolithic IC is extremely complex, so it is shown as simply "M.IC circuit".

Tr1 acts as the contacts controlling the field current, and **Tr2** acts as the charge lamp relay controlling the flashing of the charge lamp.

The M.IC circuit controls **Tr1** and **Tr2**, and monitors the alternator output voltage, and detects any drop in L terminal voltage or breaks in the rotor coil.

(1) IC Regulator

01640M90020