

Product: 2010 TEREX PT-50/60 Rubber Track Loader Service Repair Workshop Manual

Full Download: [https://www.aresairmanual.com/downloads/2010-terex-pt-5060-r](https://www.aresairmanual.com/downloads/2010-terex-pt-5060-rubber-track-loader-service-repair-workshop-manual/)

[ubber-track-loader-service-repair-workshop-manual/](https://www.aresairmanual.com/downloads/2010-terex-pt-5060-rubber-track-loader-service-repair-workshop-manual/)



TEREX®

Service Manual

Rubber Track Loader

PT-50/60

Sample of manual. Download All 85 pages at:

<https://www.aresairmanual.com/downloads/2010-terex-pt-5060-rubber-track-loader-service-repair-workshop-manual/>

Part Number: 2030-634

Printed (4-10)

Product: 2010 TEREX PT-50/60 Rubber Track Loader Service Repair Workshop Manual

Full Download: [https://www.arepairmanual.com/downloads/2010-terex-pt-5060-r](https://www.arepairmanual.com/downloads/2010-terex-pt-5060-rubber-track-loader-service-repair-workshop-manual/)

[ubber-track-loader-service-repair-workshop-manual/](https://www.arepairmanual.com/downloads/2010-terex-pt-5060-rubber-track-loader-service-repair-workshop-manual/)

Sample of manual. Download All 85 pages at:

<https://www.arepairmanual.com/downloads/2010-terex-pt-5060-rubber-track-loader-service-repair-workshop-manual/>

Table of Contents

1. Product Safety		
Chapter Overview	1-1	
Basic Precautions	1-1	
Safety Labels	1-1	
Personal Protective Equipment.....	1-1	
Entering and Exiting.....	1-2	
Lifting	1-2	
Hot Fluids and Parts	1-2	
Corrosion Inhibitor	1-2	
Batteries	1-2	
Pressurized Items.....	1-2	
Repair	1-3	
Attachments	1-4	
Machine Labels and Decals	1-4	
Product ID Number	1-4	
Safety Label Examples	1-4	
2. Technical Specifications		
PT-50 Specifications	2-1	
PT-60 Specifications	2-2	
3. System Diagrams		
Chapter Overview	3-1	
Filtering and Cooling System	3-1	
Auxiliary Circuit System	3-2	
Drive Loop System	3-3	
Electrical Attachment Outlet	3-3	
4. Machine Controls and Instrumentation		
Chapter Overview	4-1	
Machine Controls	4-1	
Loader Control	4-1	
Drive Control.....	4-1	
Throttle	4-1	
Instrumentation	4-1	
Switches.....	4-2	
5. Operator Enclosure Disassembly and Assembly		
Chapter Overview	5-1	
Personal Safety.....	5-1	
Machine Preparation	5-1	
Operator Enclosure Disassembly and Assembly Procedures.....	5-1	
Light Bar Removal and Installation.....	5-1	
Light Bar Removal	5-1	
Light Bar Installation	5-2	
Ignition Switch Removal and Installation.....	5-2	
Ignition Switch Removal	5-2	
Ignition Switch Installation	5-3	
Gauge Removal and Installation	5-4	
Gauge Removal.....	5-4	
Gauge Installation.....	5-4	
Lap Bar Gas Assist Spring Removal and Installation.....	5-5	
Lap Bar Gas Assist Spring Removal.....	5-5	
Lap Bar Gas Assist Spring Installation.....	5-5	
6. Chassis Disassembly and Assembly		
Chapter Overview	6-1	
Personal Safety.....	6-1	
Machine Preparation.....	6-1	
Chassis Disassembly and Assembly Procedures.....	6-1	
Seat Removal and Installation	6-1	
Seat Removal	6-1	
Seat Installation	6-2	
Fuel Sending Unit Removal and Installation	6-2	
Fuel Sending Unit Removal.....	6-3	
Fuel Sending Unit Installation	6-3	
7. Radiator/Oil Cooler Disassembly and Assembly		
Chapter Overview	7-1	
Personal Safety.....	7-1	
Machine Preparation.....	7-1	
Radiator/Oil Cooler Disassembly and Assembly Procedures.....	7-1	
Fan Guard Removal and Installation.....	7-1	
Fan Guard Removal	7-2	
Fan Guard Installation	7-2	
Radiator/Cooler Removal and Installation.....	7-2	
Radiator/Cooler Removal	7-2	
Radiator/Cooler Installation	7-4	
8. Hydraulic Reservoir Disassembly and Assembly		
Chapter Overview	8-1	
Personal Safety.....	8-1	
Machine Preparation	8-1	
Hydraulic Reservoir Disassembly and Assembly Procedures.....	8-1	
Filter Element Removal and Installation.....	8-1	
Filter Assembly Removal and Installation	8-1	
Filter Assembly Removal	8-2	
Filter Assembly Installation	8-3	
Access Cover Removal and Installation.....	8-4	
Access Cover Assembly Removal.....	8-4	
Access Cover Assembly Installation.....	8-4	
Reservoir Gauge Removal and Installation.....	8-5	
Reservoir Gauge Removal	8-5	
Reservoir Gauge Installation	8-6	
Suction Screen Removal and Installation	8-6	
Suction Screen Removal	8-6	
Suction Screen Installation	8-7	
Hydraulic Reservoir Cleaning Procedures	8-7	
Hydraulic Reservoir Cleaning	8-7	

9. Loader/Transmission Controls Disassembly and Assembly

Chapter Overview 9-1
Personal Safety..... 9-1
Machine Preparation..... 9-1
Loader/Transmission Controls Disassembly and Assembly Procedures 9-1
Joystick Removal and Installation 9-1
 Joystick Removal..... 9-2
 Joystick Installation..... 9-3
Loader Float Magnet Removal and Installation 9-3
 Loader Float Magnet Removal..... 9-3
 Loader Float Magnet Installation..... 9-4
Loader Valve Removal and Installation..... 9-4
 Loader Valve Removal 9-4
 Loader Valve Installation 9-6
Self Level Valve Removal and Installation 9-6

10. Transmission and Drive Disassembly and Assembly

Chapter Overview 10-1
Personal Safety..... 10-1
Machine Preparation..... 10-1
Hydrostatic and Hydraulic Pump Disassembly and Assembly Procedures 10-1
Auxiliary Gear Pump Removal and Installation 10-1
 Auxiliary Gear Pump Removal..... 10-1
Tandem Pump Removal and Installation 10-3
 Tandem Pump Removal..... 10-3
 Tandem Pump Installation 10-4
Pump Drive Coupler Removal and Installation..... 10-5
 Pump Drive Coupler Removal 10-5
 Pump Drive Coupler Installation 10-6

11. Undercarriage Disassembly and Assembly

Chapter Overview 11-1
Personal Safety..... 11-1
Machine Preparation..... 11-1
Undercarriage Disassembly and Assembly Procedures..... 11-1
Center Wheel Removal and Installation 11-1
 Wheel Removal 11-2
End Wheel Removal and Installation 11-3
 End Wheel Removal 11-3
 End Wheel Installation 11-3
Sprocket Roller Removal and Installation 11-4
Track Removal and Installation..... 11-4
 Track Removal..... 11-4
 Track Installation..... 11-4
Outboard Bearing Removal and Installation..... 11-5
 Bearing Removal 11-5
 Bearing Installation 11-5
Drive Sprocket Removal and Installation 11-6
 Sprocket Removal 11-6
 Sprocket Installation 11-6
Drive Motor Removal and Installation 11-6
 Drive Motor Removal..... 11-6
 Drive Motor Installation 11-6
Idler Wheel Hub Service Procedures 11-7
 Disassembly Procedure..... 11-7
 Assembly Procedure..... 11-9

12. Loader Disassembly and Assembly

Chapter Overview 12-1
Personal Safety..... 12-1
Machine Preparation..... 12-1
Loader Disassembly and Assembly Procedures.. 12-1
Lift Cylinder/Tilt Cylinder Removal and Installation..... 12-1
 Lift Cylinder/Tilt Cylinder Removal..... 12-1
 Lift Cylinder/Tilt Cylinder Installation..... 12-3
Q/C Block Relief Valve Removal and Installation.. 12-3
 Q/C Block Relief Valve Removal 12-3
 Q/C Block Relief Valve Installation 12-4

13. Maintenance

Chapter Overview 13-1
Maintenance Schedule 13-1
Engine Oil 13-1
 Oil Change Procedures 13-1
 Engine Oil Specifications..... 13-1
Hydraulic Fluid and Filter 13-2
 Hydraulic Fluid and Filter Change Procedures 13-2
Fuel/Water Separator..... 13-3
Fuel Filter 13-3
 Fuel Filter Change Procedures..... 13-3
 Fuel Specifications 13-3
Air Cleaner 13-3
 Air Filter Change Procedures 13-3
Track Tension 13-4
 Track Tension Adjustment Procedures..... 13-4
 Checking for Proper Track Adjustment..... 13-4
Fuse Box..... 13-5
Grease Fittings..... 13-5
Bleeding the Fuel System 13-6

14. Hydraulic Pressure Check & Adjustment

Chapter Overview 14-1
Personal Safety..... 14-1
Machine Preparation..... 14-1
Hydraulic Pressure Adjustment Procedures..... 12-1
Charge Pressure check..... 14-1
Charge Pressure Adjustment..... 14-1
Auxiliary Pressure Check & Adjustment..... 14-2

15. Troubleshooting

Chapter Overview 15-1
Personal Safety..... 15-1
Machine Preparation..... 15-1
Preliminary Inspection..... 15-1
 Visual Inspection 15-1
Troubleshooting Scenarios..... 15-2

1. Product Safety

Chapter Overview

This chapter contains product safety information for the Terex PT-50/60 Rubber Track Loaders. Read and understand all product safety information before attempting to service any Rubber Track Loader.



Safety Alert Symbol

This symbol means: **Attention! Be alert! Your safety is involved!**

The safety alert symbol is used to alert you to potential personal injury hazards. Obey all safety messages that follow this symbol to avoid possible injury or death.

This symbol is used as an attention-getting device throughout this manual as well as on decals and labels fixed to the machinery to assist in potential hazard recognition and prevention.

Property or equipment damage warnings in this publication are identified by the signal word "NOTICE".

NOTICE

"NOTICE" Indicates a hazardous situation which, if not avoided, could result in property or equipment damage.

The word "Note" is used throughout this manual to draw your attention to specific topics or to supplement the information provided in that section.



Improper or incomplete maintenance/repair of a Rubber Track Loader can be dangerous and may result in machine damage, injury or death.

Do not attempt to perform any type of repair or maintenance on a Rubber Track Loader until you have read and fully understood both this manual and the machine specific operation and maintenance manual.

Refer to the Operation and Maintenance manual for instructions regarding proper machine operation and maintenance techniques before operating or servicing any Rubber Track Loader.

The person(s) in charge of servicing a Rubber Track Loader may be unfamiliar with many of the systems on the machine. This makes it especially important to use caution when performing service tasks. Familiarize yourself with the affected system(s) and components before attempting any type of maintenance or service.

It is not possible to anticipate every potential hazard. The safety messages included in this document and displayed on the machine are not all-inclusive. They are intended to make you aware of potential risks and encourage a safe approach to performing service work. If you use a tool, procedure, work method or operating technique that is not specifically recommended by Terex, you must satisfy yourself that it is safe for you and others. You must also ensure that the machine will not be damaged or be made unsafe by the operation, lubrication, maintenance or repair procedures that you choose.



Basic Precautions

Safety Labels

Safety labels have been included and are displayed in various places throughout the machine to serve as warnings of potentially dangerous conditions. Read and understand all "Safety" labels on any Rubber Track Loader before attempting to operate, maintain or repair it. Replace any damaged, illegible or missing labels immediately, prior to service.

Personal Protective Equipment

Personal protection equipment is recommended when performing maintenance or service on a machine. Always wear appropriate protective equipment for working conditions when working on or around the machine. Loose clothing should not be worn and long hair should be restrained. Wear hard hats, protective face/eyewear, safety shoes and any other equipment necessary to ensure your safety and the safety of others around you as you work.

Entering and Exiting

Always use steps and handholds when entering or exiting a Rubber Track Loader. Clean any mud or debris from steps or work platforms before using them. Always face the machine when using steps and handholds. When it is not possible to use the designed entry/exit system, utilize ladders, scaffolds, or work platforms to safely gain access to the machine.

Lifting

Use a hoist when lifting components that weigh 50 lb (23 kg) or more, to avoid back injury. Make sure all chains, hooks, slings, etc., are in good condition and are of the correct capacity. Be sure hooks are positioned correctly and equipped with a spring latch. Lifting eyes are not to be side loaded during a lifting operation.

Hot Fluids and Components

Stay clear of hot components and system fluids of the engine, exhaust, radiator/oil cooler and hydraulic lines/tubes. Also, use caution when removing fill caps, breathers and plugs on the machine. Hold a rag over the cap or plug to prevent being sprayed or splashed by liquids under pressure. Be especially careful if the machine has been operated recently, fluids may still be hot. To ensure your safety, allow the machine to cool before attempting any service procedure that involves hot fluids or components.

Corrosion Inhibitor

Corrosion inhibitor contains alkali. Avoid contact with eyes. Avoid prolonged or repeated contact with skin. Do not take internally. In case of contact, wash skin immediately with soap and water. For eyes, flush with large amounts of water for at least 15 minutes. Call Physician. Keep out of reach of children.

Batteries

Do not smoke when inspecting the battery electrolyte level. Never disconnect any charging unit circuit or battery circuit cable from the battery when the charging unit is operating. A spark can cause an explosion from the flammable vapor mixture of hydrogen and oxygen that is released from the electrolyte through the battery outlets. Do not let electrolyte solution make contact with skin or eyes. Electrolyte solution is an acid. In case of contact, immediately wash skin with soap and water. For eyes, flush with large amounts of water for at least 15 minutes. Call Physician. Keep out of reach of children.

Pressurized Items

1. Do not use hands or any other body part to check for fluid leaks in the hydraulic system. Always use a solid material like wood or metal to check for this type of leak. Leaking fluid under pressure can penetrate body tissue. Fluid penetration can cause serious injury and even death. If fluid is injected into your skin, get treatment immediately. Seek treatment from a doctor that is familiar with this type of injury.
2. Relieve pressure from the hydraulic system before disconnecting or removing any lines, fittings or related items. Do this by relaxing all hydraulic actuators. If the lift arms are raised, make sure they are securely braced. Be alert for possible pressure release when disconnecting any device from a pressurized system.
3. Lower the lift arms before performing any work on the machine. If this cannot be done, make sure they are securely braced to prevent them from dropping unexpectedly during service.
4. Loose or damaged fuel, oil, hydraulic, lines, tubes and hoses can cause fires. Do not bend or strike high pressure lines or install ones that have been bent or damaged. Check lines, tubes and hoses carefully. See item 1 for precautions on checking for fluid leaks.
5. Pressurized air or water can also cause injury. When pressurized air or water is used for cleaning, wear a protective face shield, protective clothing, and protective shoes. The recommended maximum air pressure for cleaning purposes is 30 psi (205 kPa). When using a pressure washer, keep in mind that nozzle pressures are typically very high. Generally, pressures are well above 2000 psi (13790 kPa). Follow all recommended practices provided by the pressure washer manufacturer.



Repair



Accidental machine starting can cause injury or even death to personnel working on a Rubber Track Loader.

As a precaution, disconnect the battery cables from the battery terminals, tape the battery clamps and remove the key from the ignition switch prior to performing any service work on a Rubber Track Loader.

Place a “Do Not Operate” tag prominently on the machine to inform personnel that the machine is being serviced.

1. Disconnect the battery and discharge any capacitor before beginning work on a machine. Attach a **Do Not Operate** tag in the cab to alert any operator that service is in progress.
2. If possible, make all repairs with the machine parked on a level, hard surface. Use blocks to prevent the machine from rolling while working on or under the machine.
3. Do not work on or under any machine that is supported only by a hydraulic jack or hoist. Always use some sort of mechanical support to ensure that the machine will not fall. Terex jack stands work well to support the machine while performing maintenance or repair work.
4. Make sure the work area around the machine is safe and make yourself aware of any hazardous conditions that may exist. If the engine needs to be started inside an enclosure, make sure that the engine's exhaust is properly vented.
5. Be sure all protective devices including guards and shields are properly installed and functioning correctly before beginning any service task. If a guard or shield must be removed to perform the repair work, use extra caution.
6. Always use the appropriate tools for the work to be performed. Tools should be in good condition and you should understand how to use them properly before performing any service work.
7. When replacing fasteners, use parts of equivalent grade and size. Do not use a lesser quality fastener if replacements are necessary.
8. Be prepared to stop an engine if it has been recently overhauled or the fuel system has been recently serviced. If the engine has not been assembled correctly, or if the fuel settings are not correct, the engine can possibly overspeed and cause bodily injury, death or property damage. Be prepared to shut off the fuel and air supply to the engine in order to stop the engine.
9. Be careful when removing cover plates. Gradually back off the last two bolts or nuts located on opposite sides of the cover. Then, pry the cover loose to relieve any spring or other pressure before removing the last two nuts or bolts completely.
10. Repairs requiring welding should be performed only by personnel adequately trained and knowledgeable in welding procedures and with the guidance of appropriate reference information. Determine the type of metal being welded and select the correct welding procedure and filler material to provide a weld that is as strong or stronger than the original weld.
11. Take precautions to avoid damaging wiring during removal and installation operations. Carefully route wires so that they will not contact sharp corners, objects or hot surfaces during operation.
12. When performing service that requires the lift arms to be in the raised position, always utilize the lift arm brace located on the rear of the loader tower.
13. Relieve hydraulic system pressure by relaxing all hydraulic actuators prior to attempting any hydraulic maintenance or repair.
14. Always tighten connections to the correct torque specification. Make sure that all shields, clamps and guards are installed correctly to avoid excessive heat, vibration or unwanted contact between parts during operation. Shields that protect exhaust components from oil spray in event of a line, tube or seal failure must be correctly installed.
15. Do not operate a machine if any rotating part is damaged or contacts other parts during operation. Any high speed rotating component that has been damaged or altered should be checked for balance before reusing. Make sure all protective devices, including guards and shields, are properly installed and functioning correctly before starting the engine or operating the machine.

1. Product Safety

⚠ Attachments

Only use attachments that are recommended by Terex.

Make sure that all necessary guards and protective equipment are in place and functioning prior to operating any attachment.

Wear protective glasses and protective equipment as required by conditions or as recommended in the attachment's operation manual.

	<p>When replacement parts are required for your machine, use only genuine Terex replacement parts or parts that meet or exceed original specifications including, but not limited to physical dimensions, type, strength and material.</p> <p>Installing lesser components can lead to premature failures, product damage, personal injury or death.</p>
---	--

Ensure that all personnel are far enough away from the work area so they will not be struck by flying objects.

Stay clear of the cutting edges, pinching surfaces or crushing surfaces of the attachment while performing any attachment maintenance, testing or adjustments.

⚠ Machine Labels and Decals

Labels and decals placed on the machine provide safety information and operating instructions. Familiarize yourself with the location and significance of these labels to ensure your safety.

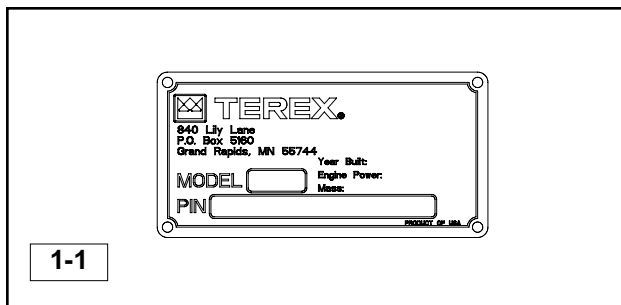

Product Identification Number

The Product Identification Number (PIN) is located on the left side of the firewall next to the operator seat. (figure 1-1). Always provide the PIN when contacting the dealer about parts, service, warranty or accessories. No warranty claims will be processed unless the PIN is provided.







⚠ Safety Label Examples

Examples of the labels and decals displayed on the machine are shown on this page.



<p>⚠ WARNING</p>  <p>Crush Hazard Death or serious injury can result from contact with moving lift arm or attachment.</p>	 <p>Keep clear of lift arms and attachments.</p>
--	---

<p>⚠ WARNING</p>  <p>CRUSH HAZARD Contact with moving machine can result in death or serious injury.</p>	 <p>Keep clear of moving machine.</p> <p style="text-align: right; font-size: small;">2030-593</p>
---	---

<p>⚠ WARNING</p>  <p>Fall Hazard Serious injury or death can result from falling.</p>	 <p>Use the provided access system when entering or exiting the machine.</p>
--	---



<p>⚠ WARNING</p>  <p>Crush Hazard Death or serious injury can result from contact with moving lift arm or attachment.</p>	 <p>Install lift arm brace prior to servicing.</p>
--	---

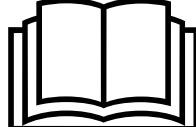

<p>⚠ WARNING</p>  <p>Entanglement Hazard Rotating parts can cause personal injury.</p>	 <p>Keep away from fan and belt while the engine is running. Stop engine before servicing.</p> <p style="text-align: right; font-size: small;">2030-600</p>
--	--





<p>⚠ WARNING</p>  <p>Burn Hazard Hot fluid under pressure can scald.</p>	 <p>Allow the machine to cool thoroughly before opening.</p> <p style="text-align: right; font-size: small;">2030-595</p>
---	--



<p>NOTICE</p>  <p>Fire Hazard Flammable debris can collect near hot components and lead to a fire.</p>	 <p>Read Operator's manual Keep engine, exhaust and chassis areas free of debris.</p>
--	---

! WARNING	! WARNING
 Crush Hazard Rollover can crush and result in serious injury or death.	 Fall Hazard Falling can result in serious injury or death.
 Fasten Seat Belt	 Do not use the bucket/attachment as a work platform.

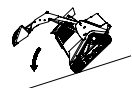
! DANGER
 Explosion/Burn Hazard Will cause death, burns or blindness due to ignition of explosive gasses or contact with corrosive acid.
 
<ul style="list-style-type: none"> • Keep all flames/sparks away! • No Smoking! • Read and understand all manuals prior to operation.

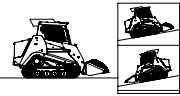
! WARNING
 Burn Hazard Contact with hot surfaces can cause burns.

<ul style="list-style-type: none"> • Do not touch hot components! • Allow the machine to cool thoroughly prior to servicing.

! WARNING	! WARNING	! WARNING
 Improper operation or maintenance can result in serious injury or death.	 Fall Hazard Falling from a machine can result in serious injury or death.	 Rollover/Ejection Hazard Serious injury or death can result.
 Read Operator's Manual Read and understand the operator's manual and all safety signs prior to operating or maintaining the machine.	 No Riders	 Carry loads low. Load unload and turn on level ground. Travel on inclines with heaviest end of machine uphill.

! WARNING	
 Injection Hazard Escaping fluid under pressure can penetrate skin, causing serious injury.	<ul style="list-style-type: none"> • Relieve internal pressure before disconnecting any line or fitting. • Keep away from leaks or pinholes. • Use cardboard to check for leaks. Fluid injected into skin must be surgically removed within a few hours by a doctor familiar with this type of injury or gangrene will result.

2. Technical Specifications

PT-50 Specifications

Engine

- Model: Perkins 404D-22
- Displacement: 2.2 liter
- Gross horsepower: 50 hp, 37.3 kW
- Torque: 105 lb-ft.143 Nm
- Idle rpm: 2800 (high idle); 1175 (low idle)
- Average water /thermostat temperature: 190°F, 87.8°C

Transmission

- Model: A22 (38.5cc) tandem (Rexroth)

Drive pumps

- Displacement: 2.349 in³/rev (38.5 cc/rev)
- Relief pressure: 5500 psi, 380 bar
- Flow: 28 gpm (106 lpm) @ 2800 rpm (high idle)

Charge pump

- Displacement: 1.098 in³/rev (18 cc/rev)
- Relief pressure: 400-450 psi

Drive Motors

- Model: Rexroth MCR 05C
- Displacement: 37.8 in³/rev (620 cc/rev)

Control Handles

- Model: 4TH6 (Rexroth)

Auxiliary Pump

- Make: Haldex-Barnes #180-2061
- Displacement: 1.343 in³/rev (22 cc/rev)
- Flow: 16.27 gpm (61.85 lpm) @ 2800 rpm (high idle)
- Relief pressure: 3000 psi (20,684 kPa)
- Cooling/filtering: Auxiliary oil is filtered and cooled at all times. In Auxiliary mode, the oil is filtered after the attachment to protect the machine if the attachment motor fails or contaminants are introduced from the quick couplers.

Loader Valve

- Model: Husko
- Relief pressure: 3000 psi (20,684 kPa)
- Pilot pressure required to move spools: 180-220 psi (1241-1517 kPa)

Cooler

- Burst pressure: 400 psi (2757 kPa)
- Operating pressure: 250 psi (1724 kPa)
- Bypass relief pressure: 80 psi (689 kPa)
- Hot oil sending unit: 225°F (107.2°C)

Critical Torque Specs

- Transmission Mounting Bolts
 - o 85 ft-lb. w/Blue Loctite
- Drive Sprocket Drive Teeth Bolts
 - o 88 ft-lb. -Dry
- Center Bogie Wheel Retaining Nut
 - o 111 ft-lb. -Dry
- End Wheel Axle Retaining Nut
 - o 300 ft-lb. -Dry
- Drive Sprocket Lug Nut
 - o 129 ft-lb. -Dry
- Drive Motor Mounting Bolts
 - o 177 ft-lbs. -Dry

PT-60 Specifications

Engine

- Model: Perkins 404D-22 T
- Displacement: 2.2 liter
- Gross horsepower: 60 hp, 44.7 kW
- Torque: 140 lb-ft.190 Nm
- Idle rpm: 2800 (high idle); 1175 (low idle)
- Average water /thermostat temperature: 190°F, 87.8°C

Transmission

- Model: A22VG (38.5cc) tandem (Rexroth)

Drive pumps

- Displacement: 2.349 in³/rev (38.5 cc/rev)
- Relief pressure: 5500 psi, 380 bar
- Flow: 28 gpm (106 lpm) @ 2800 rpm (high idle)

Charge pump

- Displacement: 1.098 in³/rev (18 cc/rev)
- Relief pressure: 400-450 psi (2758-3103 kpa)

Drive Motors

- Model: Rexroth MCR 5 (2-speed)
- Displacement: 50 in³/rev (820 cc/rev)

Control Handles

- Model: 4TH6 (Rexroth)

Auxiliary Pump

- Make: Haldex-Barnes #180-2061
- Displacement: 1.343 in³/rev (22 cc/rev)
- Flow: 17.4 gpm (65.9 lpm) @ 2800 rpm (high idle)
- Relief pressure: 3000 psi (20,684 kPa)
- Cooling/filtering: Auxiliary oil is filtered and cooled at all times. In Auxiliary mode, the oil is filtered after the attachment to protect the machine if the attachment motor fails or contaminants are introduced from the quick couplers.

Loader Valve

- Model: Husco
- Relief pressure: 3000 psi (20,684 kPa)
- Pilot pressure required to move spools: 40-320 psi (275.8-2206 kPa)

Cooler

- Burst pressure: 400 psi (2757 kPa)
- Operating pressure: 250 psi (1724 kPa)
- Bypass relief pressure: 80 psi (689 kPa)
- Hot oil sending unit: 225°F (107.2°C)

Critical Torque Specs

- Transmission Mounting Bolts
 - o 85 ft-lb. (230 Nm) w/Blue Loctite
- Drive Sprocket Drive Teeth Bolts
 - o 105 ft-lb. (142 Nm) -Dry
- Wheel Axle Retaining Nut
 - o 300 ft-lb. (407 Nm)-Dry
- Drive Sprocket Lug Nut
 - o 129 ft-lb. (175 Nm)-Dry
- Drive Motor Mounting Bolts
 - o 177 ft-lbs. (480 Nm) -Dry
- Center Idler Wheel Mounting Bolts
 - o 105 ft-lbs. (142 Nm) -Dry

3. System Diagrams

Chapter Overview

This chapter contains diagrams for the following PT-50/60 systems.

- Filtering and cooling system
- Auxiliary circuit system
- Drive loop system

Figure 3-1

Filtering and Cooling System

The filtering and cooling system (Figure 3-1) contains the following major components.

- Hydraulic reservoir
- Radiator/oil cooler
- Loader valve

PT-50/60 Filtering and Cooling System

3-001

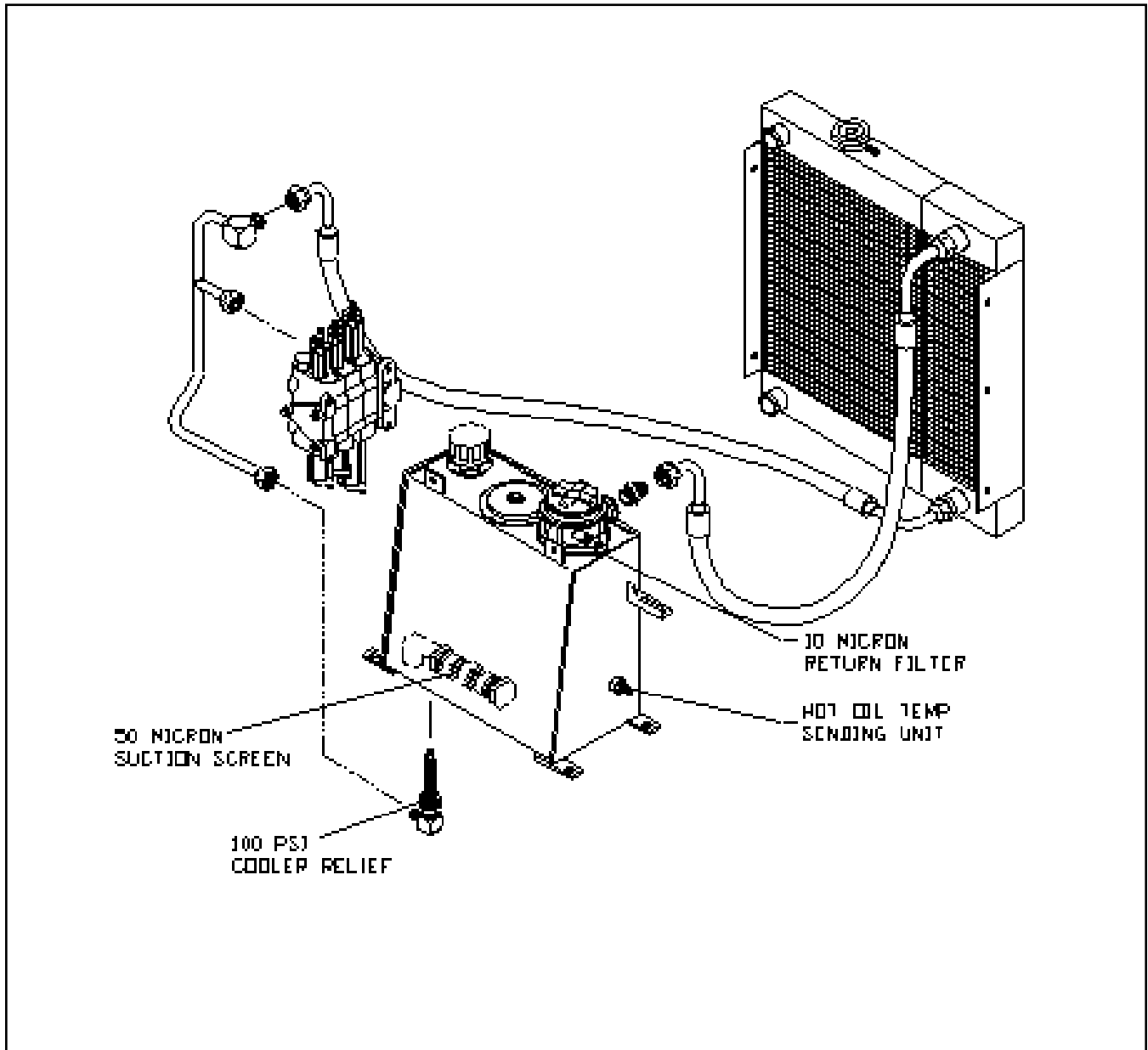

Auxiliary Circuit System

The auxiliary circuit system (fig. 3-2) contains the following major components.

- Loader valve
- Pilot control manifold
- Auxiliary gear pump
- Loader control joystick

Figure 3-2

PT-50/60 Auxiliary Circuit System

3-002

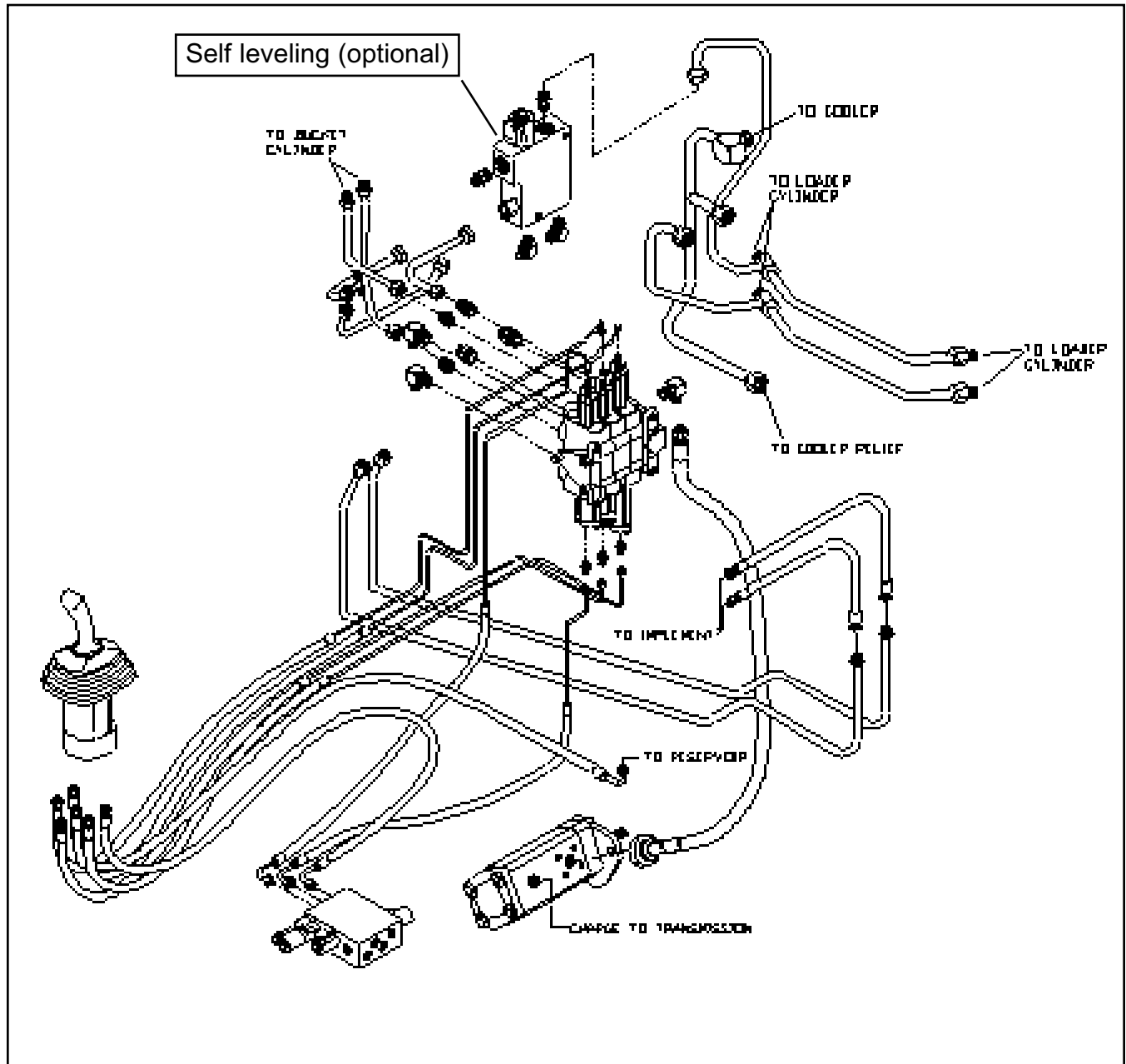

Drive Loop System

The drive loop system (fig. 3-3) contains the following major components.

- Drive motors
- Pilot control manifold
- Drive control joystick
- Tandem pump

Figure 3-3

PT-50/60 Drive Loop System

3-003

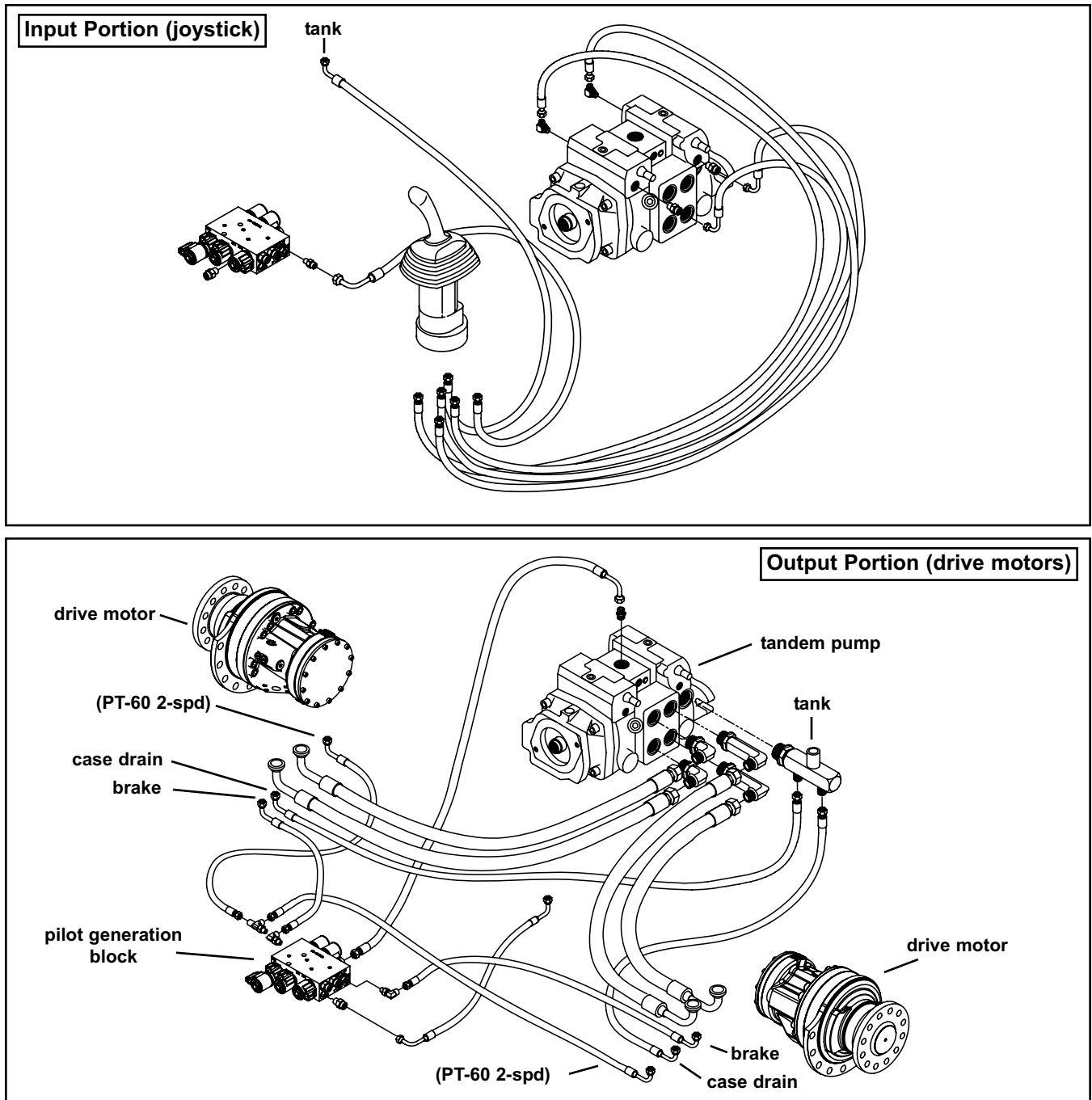

Electrical Attachment Outlet

Figure 3-4 PT-50/60 Electrical Attachment Outlet

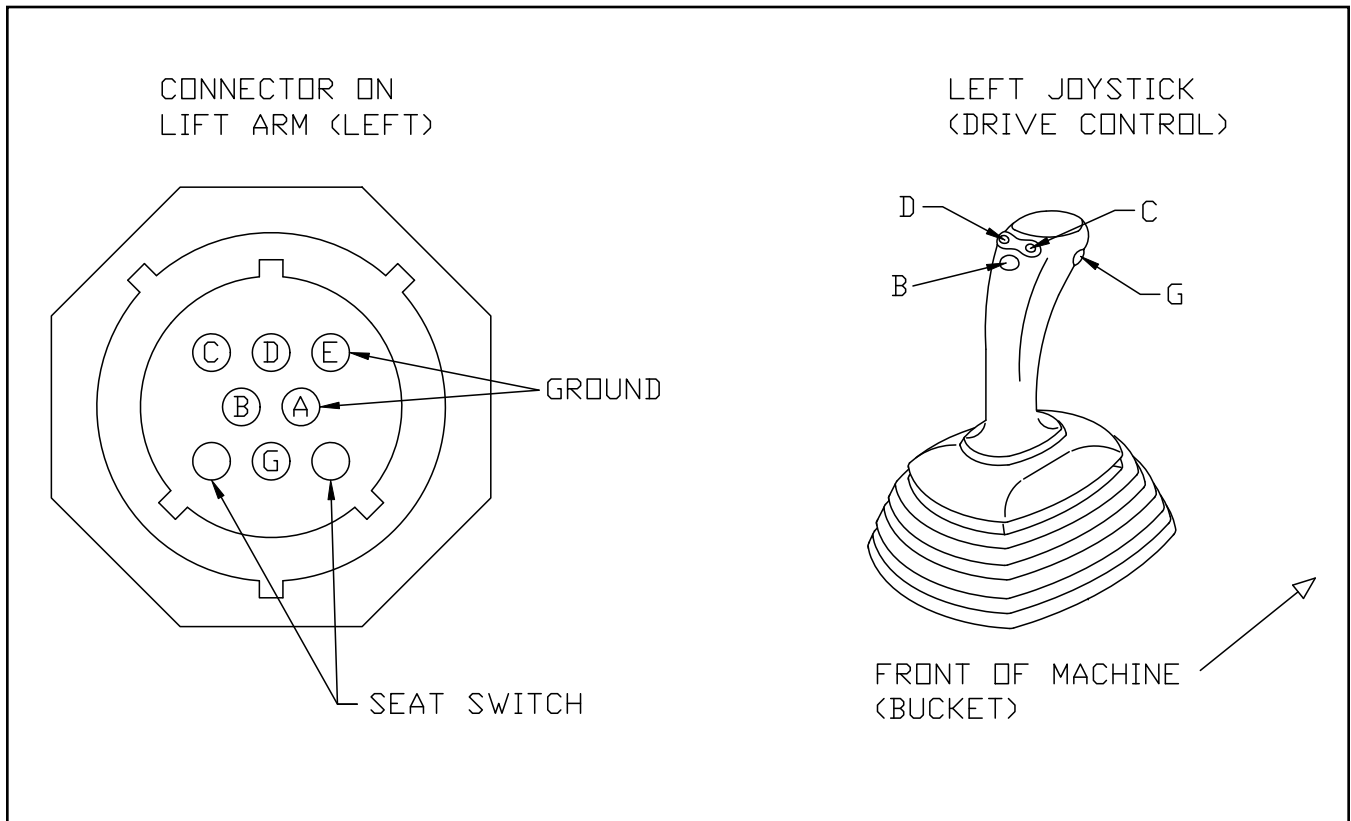

4. Machine Controls and Instrumentation

Chapter Overview

This chapter contains an overview of the machine controls and instrumentation. For further information regarding machine controls, instrumentation or operation, refer to the operation and maintenance manual for your particular machine. Included here are illustrations of the following controls and instrumentation components and a description of their functions.

- Machine Controls
- Instrument Location and Function
- Switch Location and Function

Machine Controls (fig. 4-1)

There are three primary machine controls: lift arm control (2), drive control (1) and throttle (3).

Lift Arm Control

The lift arm control (2) is a pilot operated joystick that allows the operator to raise or lower the loader and dump or curl the quick attach mechanism.

Drive Control

The drive control (1) is also a pilot operated joystick. It allows the operator to change the direction and speed of the machine.

Throttle

The hand throttle (3) controls engine rpm.

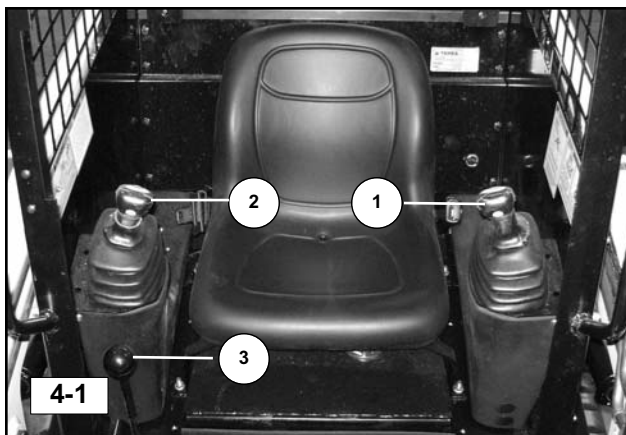

Instrumentation

The Instruments (Figure 4-2) are positioned in the overhead dash panel for ease of access and visibility when seated inside the operator enclosure. Instruments include the following components.

- (1) Fuel Gauge
- (2) Tachometer (optional)
- (3) Engine Coolant Temp. Gauge (optional)
- (4) Hour Meter
- (5) Warning Indicator Display
 - Engine Oil Pressure Warning Light
 - Engine Temperature Warning Light
 - Hydraulic Oil Temperature Warning Light
 - Battery Voltage Warning Light

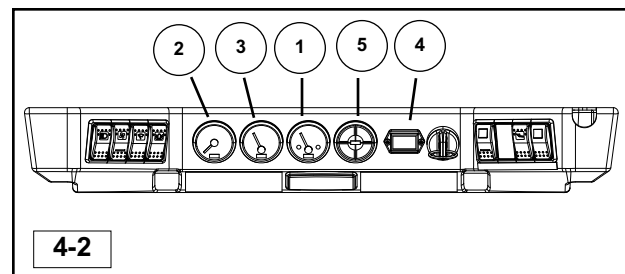

NOTICE

If the engine temperature, engine oil pressure or hydraulic oil temperature lights illuminate or should the eng. coolant temp. gauge read excessive temperatures during normal machine operation, shut the machine down immediately (in a safe location). Diagnose the problem and make any necessary repairs before resuming normal operation.

NOTICE

If the battery low-voltage light should illuminate during operation, drive the machine to a suitable location and shut the engine off. Diagnose the problem and make any needed repairs before resuming operation.

The glow plug operation light illuminates only when the key switch is turned to engine pre-heat, showing normal operation.

PT-50/60 Switches

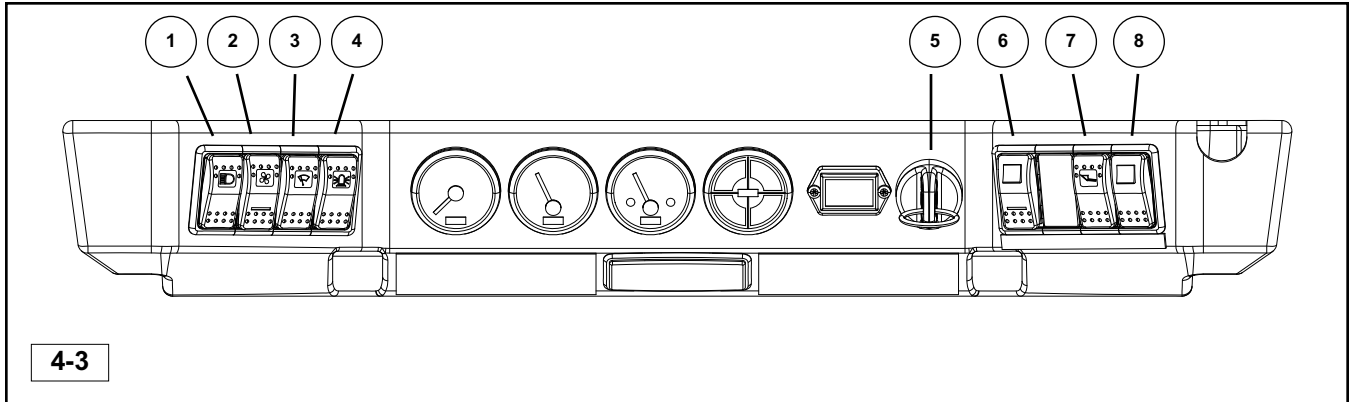

The various switches (Figure 4-3) are positioned to provide good access and visibility. The standard and optional switches are listed below.

- (1) Work lights
- (2) Heater fan (optional)
- (3) Front wiper (optional)
- (4) Beacon light (optional)
- (5) Ignition, glow plug (pre-heat)
- (6) Auxiliary hydraulics
- (7) Bucket Positioning (optional)
- (8) Power Quick Attach (optional)

5. Operator Enclosure Disassembly and Assembly

Chapter Overview

This chapter provides disassembly and assembly procedures for the operator enclosure assembly.

Personal Safety

Improper or incomplete maintenance/repair of a Rubber Track Loader can be dangerous and may result in machine damage, injury or death.

Do not attempt to perform any type of repair or maintenance on a Rubber Track Loader until you have read and fully understood the information in this manual.

Refer to the Operation and Maintenance manual for instructions regarding proper machine operation techniques before operating any Rubber Track Loader.

Prior to performing any type of service work on a Rubber Track Loader, read and understand Chapter 1 (Product Safety) for personal safety information.

Machine Preparation

Accidental machine starting can cause injury or death to personnel working on a Rubber Track Loader.

As a precaution, disconnect the battery cables from the battery terminals, tape the battery clamps and remove the key from the ignition switch prior to performing any service work on a Rubber Track Loader.

Place a "Do Not Operate" tag prominently on the machine to inform personnel that the machine is being worked on.

Operator Enclosure Disassembly and Assembly Procedures

Disassembly and assembly procedures are provided for the following operator enclosure components.

- Light Bar
- Ignition Switch
- Gauges
- Lap Bar Gas Assist Spring

Note: Procedures are provided for only those operator enclosure components listed above. However, information for removal and installation of other operator enclosure components can be obtained from the machine specific parts manual.

Light Bar Removal and Installation

The tools required for light bar console removal and installation are listed in Table 5-1. Use manufacturer recommended tools whenever possible.

Table 5-1

Required Tools
Combination Wrench

Light Bar Removal



Figure 5-1

1. Loosen the two cap screws that attach the light bar to the cab frame.



Figure 5-2

- Carefully lower the light bar with the wire harness attached.



Figure 5-3

- View of light bar interior components. Interior components are now accessible for servicing.



Figure 5-4

- View of dome light. If removal is required, simply insert a lever (blade-type screw driver) at opposite end of switch in pry-pocket, and gently pry the light assembly out of the light bar.

Light Bar Installation



Figure 5-5

- Carefully position the light bar, without pinching the wiring harness against the cab roof.



Figure 5-6

- Secure the light bar to the cab roof with the two capscrews

Ignition Switch Removal and Installation

The tools required for ignition switch removal and installation are listed in Table 5-2. Use manufacturer-recommended tools whenever possible.

Table 5-2

Required Tools
Combination Wrench

Ignition Switch Removal

- Lower the light bar. Refer to *Chapter 5. Light Bar Removal* procedure.

5. Operator Enclosure Disassembly and Assembly



Figure 5-7

2. Remove the nut that secures the ignition switch to the dash panel.

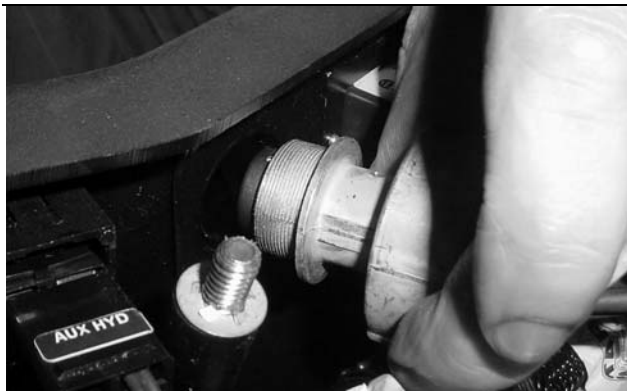

Figure 5-8

3. Pull the ignition switch out from the rear of the dash panel.



Figure 5-9

4. Unplug the ignition switch connector.

Ignition Switch Installation

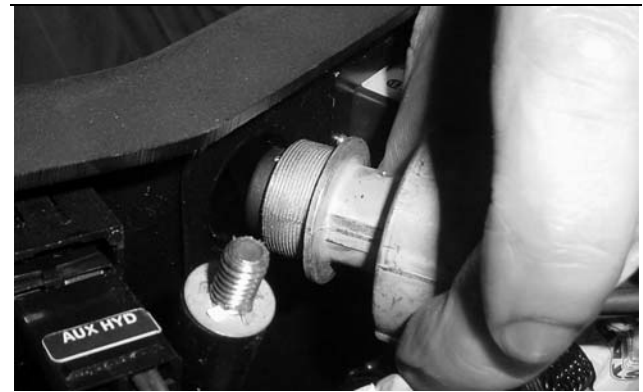

Figure 5-10

1. Insert the ignition switch from the rear of the dash panel.

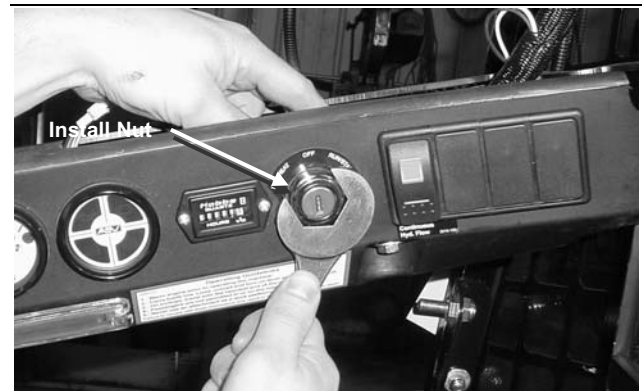

Figure 5-11

2. Install the nut that secures the ignition switch to the dash panel.



Figure 5-12

3. Plug in the ignition switch connector.

4. Install the light bar. Refer to *Chapter 5. Light Bar Installation* procedure.

Gauge Removal and Installation

The tools required for gauge removal and installation are listed in Table 5-3. Use manufacturer-recommended tools whenever possible.

Table 5-3

Required Tools
Combination wrench

Gauge Removal

1. Lower the light bar. Refer to *Chapter 5. Light Bar Removal* procedure.



Figure 5-13

2. Disconnect the connector from the gauge.



Figure 5-14

3. Remove the two nuts that secure the gauge to the retaining bracket.



Figure 5-15

4. Pull the gauge out from the front of the dash panel.

Gauge Installation



Figure 5-16

1. Insert the gauge from the front of the dash panel.



Figure 5-17

2. Install the two nuts that secure the gauge to the retaining bracket.

5. Operator Enclosure Disassembly and Assembly



Figure 5-18

3. Reconnect the gauge connector.
4. Install the light bar. Refer to *Chapter 5. Light Bar Installation* procedure.

Lap Bar Gas Assist Spring Removal and Installation

The tools required for gas assist spring removal and installation are listed in Table 5-4. Use manufacturer-recommended tools whenever possible.

Table 5-4

Required Tools
Screwdriver

Lap Bar Gas Assist Spring Removal

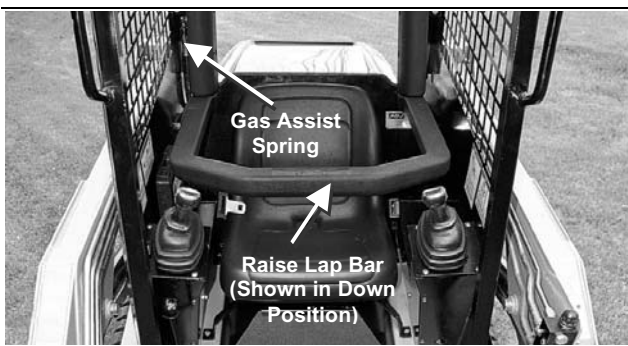

Figure 5-19

1. Put the lap bar in the UP position to relieve tension on the lap bar gas assist spring.

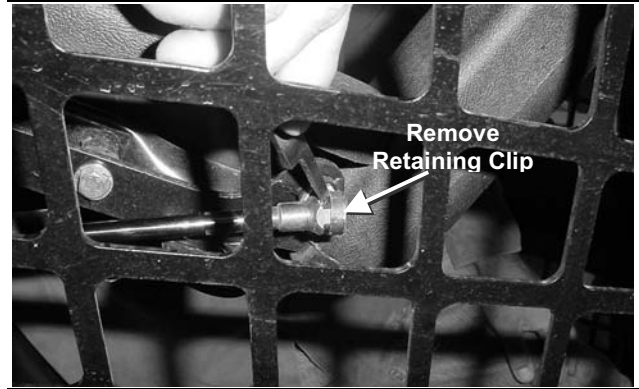

Figure 5-20

2. Using a small screwdriver, remove the retaining clip from each end of the gas assist spring.



Figure 5-21

3. Remove the gas assist spring by pulling both ends out from the ball joints.

Lap Bar Gas Assist Spring Installation



Figure 5-22

1. Put the lap bar in the UP position to minimize tension on the lap bar gas assist spring during installation.

5. Operator Enclosure Disassembly and Assembly

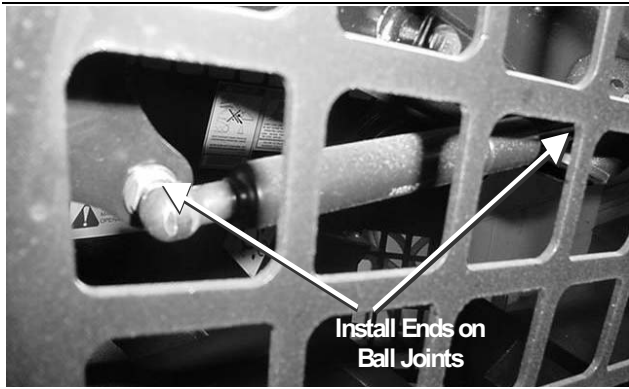

Figure 5-23

2. Install the ends of the lap bar gas assist spring onto the ball joints.

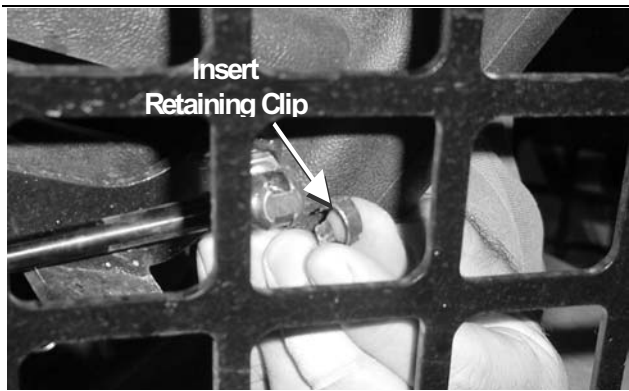

Figure 5-24

3. Slide the retaining clip on to each end of the gas assist spring.

6. Seat & Fuel Sender Disassembly and Assembly

Chapter Overview

This chapter provides disassembly and assembly procedures for the chassis assembly.

Personal Safety

Improper or incomplete maintenance/repair of a Rubber Track Loader can be dangerous and may result in machine damage, injury or death.

Do not attempt to perform any type of repair or maintenance on a Rubber Track Loader until you have read and fully understood the information in this manual.

Refer to the Operation and Maintenance manual for instructions regarding proper machine operation techniques before operating any Rubber Track Loader.

Prior to performing any type of service work on a Rubber Track Loader, read and understand Chapter 1 (Product Safety) for personal safety information.

Machine Preparation

Accidental machine starting can cause injury or death to personnel working on a Rubber Track Loader.

As a precaution, disconnect the battery cables from the battery terminals, tape the battery clamps and remove the key from the ignition switch prior to performing any service work on a Rubber Track Loader.

Place a "Do Not Operate" tag prominently on the machine to inform personnel that the machine is being worked on.

Chassis Disassembly and Assembly Procedures

Disassembly and assembly procedures are provided for the following chassis components.

- Seat
- Fuel Sending Unit
- Fuel Sending Unit Hose
- In-Tank Weight

Note: Procedures are provided for only those chassis components listed above. However, information for removal and installation of other chassis components can be obtained from the exploded view illustration provided in the Rubber Track Loader Parts manual.

Seat Removal and Installation

The tools required for seat removal and installation are listed in Table 6-1. Use manufacturer-recommended tools whenever possible.

Table 6-1

Required Tools
Socket Wrench

Seat Removal

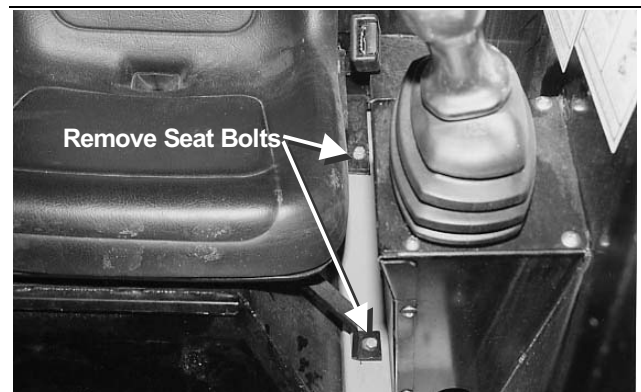

Figure 6-1

1. Remove the four nuts that fasten the seat mounts to the frame.

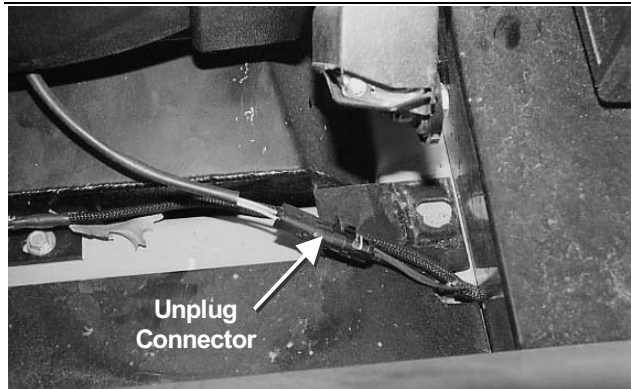

Figure 6-2

2. Tilt the seat forward and reach behind the seat to unplug the seat switch wiring harness.



Figure 6-3

3. Remove the seat. Be careful not to scratch the control panel or sides of the cab.

Seat Installation



Figure 6-4

1. With the seat mounts attached, place the seat in the cab. Be careful not to scratch the control panel or sides of the cab.

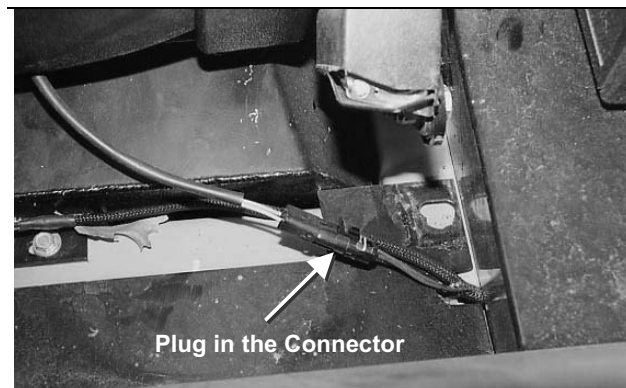

Figure 6-5

2. Tilt the seat forward and reach behind the seat to plug in the seat switch connector

Note: The machine will not operate unless the seat switch connector is plugged in.

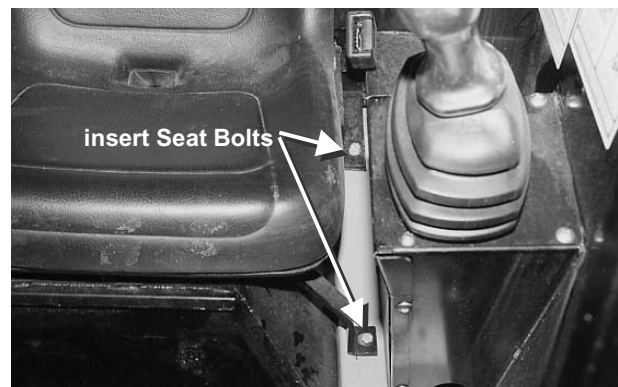

Figure 6-6

3. Position the seat so the holes in the seat mounts are aligned with the bolts in the frame. Install the four seat mount nuts and washers.

Fuel-Sending Unit Removal and Installation

The tools required for fuel sending unit removal and installation are listed in Table 6-2. Use manufacturer-recommended tools whenever possible.

Table 6-2

Required Tools
Screwdriver
Combination Wrench
Socket Wrench

Fuel Sending Unit Removal

1. Remove the seat. Refer to *Chapter 6. Seat Removal* procedure.
2. Pump fuel from the tank until there is no fuel remaining above the sending unit.

⚠ Collect and contain liquids in a suitable container. Dispose of all liquids according to local regulations and mandates.

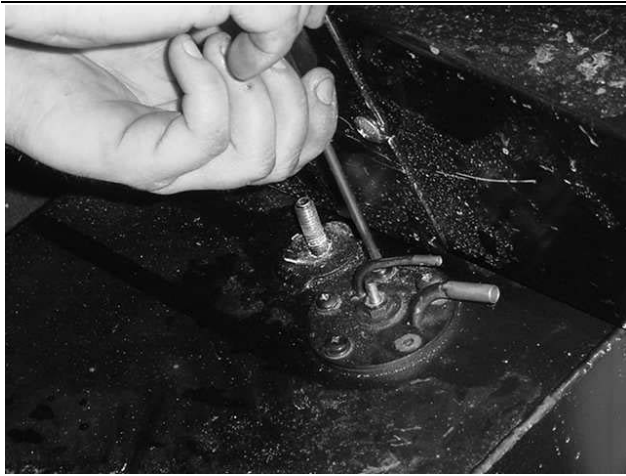

Figure 6-7

3. Remove the hoses and wires from the fuel-sending unit, then remove the screws that fasten the unit to the tank. Mark the wires and hoses.

Note: If the fuel sending unit wires are crossed, the fuel gauge will not work. If the hoses are crossed, the engine will not run.



Figure 6-8

4. Remove the fuel-sending unit. Be careful not to damage the float mechanism when pulling it through the opening in the fuel tank.



Figure 6-9

5. The fuel pickup line will also come out with the fuel-sending unit.

Fuel Sending Unit Installation



Figure 6-10

1. Insert the fuel pickup line into the fuel tank opening. The pickup line is attached to the fuel-sending unit.

Note: The weight on the end of the fuel pickup line must rest on the bottom of the tank for proper operation.

2. Insert the fuel sending unit float mechanism into the fuel tank opening. Be careful not to damage the float when pushing it through the opening.

6. Chassis Disassembly and Assembly

Note: Make sure that the wire on the sending unit is not bent and the fuel pickup line does not interfere with the movement of the float.

3. Connect the hoses and wires to the fuel-sending unit, and then install the screws that fasten the unit to the tank.

Note: Be careful not to cross the wires or hoses. If the fuel sending unit wires are crossed, the fuel gauge will not work. If the hoses are crossed, the engine will not run.

4. Install the seat. Refer to *Chapter 6. Seat Installation* procedure.

7. Radiator/Oil Cooler Disassembly and Assembly

Chapter Overview

This chapter provides disassembly and assembly procedures for the radiator/oil cooler assembly. Adjustment procedures are also included for selected radiator/oil cooler components.

Personal Safety

Improper or incomplete maintenance/repair of a Rubber Track Loader can be dangerous and may result in machine damage, injury or death.

Do not attempt to perform any type of repair or maintenance on a Rubber Track Loader until you have read and fully understood the information in this manual.

Refer to the Operation and Maintenance manual for instructions regarding proper machine operation techniques before operating any Rubber Track Loader.

Prior to performing any type of service work on a Rubber Track Loader, read and understand Chapter 1 (Product Safety) for personal safety information.

Machine Preparation

Accidental machine starting can cause injury or death to personnel working on a Rubber Track Loader.

As a precaution, disconnect the battery cables from the battery terminals, tape the battery clamps and remove the key from the ignition switch prior to performing any service work on a Rubber Track Loader.

Place a "Do Not Operate" tag prominently on the machine to inform personnel that the machine is being worked on.

Radiator/Oil Cooler Disassembly and Assembly Procedures

Disassembly and assembly procedures are provided for the following radiator/oil cooler components.

- Fan Guard
- Radiator/Cooler

Note: Procedures are provided for only those radiator/oil cooler components listed above. However, information for removal and installation of other radiator/oil cooler components can be obtained from the machine specific parts manual.

Note: Refer to Figure 3-1 for an overview of the filtering and cooling system.

Fan Guard Removal and Installation

The tools required for fan guard removal and installations are listed in Table 7-1. Use manufacturer-recommended tools whenever possible.

Table 7-1

Required Tools
Combination Wrench

Fan Guard Removal



Figure 7-1

1. Remove the bolts that secure the fan guard to the fan shroud.
2. Remove the fan guard from the engine compartment.

Fan Guard Installation

1. Position the fan guard over the fan and against the fan shroud.
2. Install the capscrews that secure the fan guard to the fan guard mounts.

Radiator/Cooler Removal and Installation

The tools required for radiator/cooler removal and installations are listed in Table 7-2. Use manufacturer-recommended tools whenever possible.

Table 7-2

Required Tools
Combination Wrench
Socket Wrench
Screwdriver

Radiator/Cooler Removal

⚠ Hot oil can cause personal injury. Make sure the oil is cool before removing any components or lines.
Remove the oil filler cap only when the engine is stopped and has been allowed to cool thoroughly.

⚠ Personal injury can result from hot coolant, steam and alkali.
At operating temperature, engine coolant is hot and under pressure. The radiator and hoses contain hot coolant and steam. Allow the machine to cool thoroughly prior to performing service or repair procedures to avoid burns.
Remove the filler cap slowly to relieve pressure only when the engine is stopped and the machine has been allowed to cool thoroughly.
Cooling system conditioner contains alkali. Avoid contact with skin and eyes.

⚠ Collect and contain liquids in a suitable container. Dispose of all liquids according to local regulations and mandates.

1. Drain the hydraulic fluid. Refer to *Chapter 13. Hydraulic Fluid and Filter Change.*