

Product: New Holland H9870/H9880 Bale Wagons Service Repair Manual  
Full Download: <https://www.arespairmanual.com/downloads/new-holland-h9870-h9880-bale-wagons-service-repair-manual/>

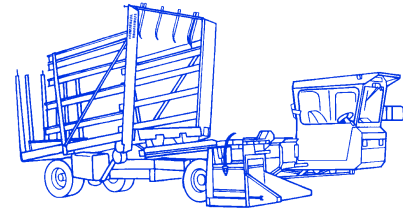

# NEW HOLLAND

## H9870

## H9880

### BODY AND STRUCTURE - E

# REPAIR MANUAL



## SERVICE

84175495 10/08  
Replaces 87717875

# H9870, H9880 REPAIR MANUAL CONTENTS

DISTRIBUTION SYSTEMS - A

POWER PRODUCTION - B

POWER TRAIN - C

TRAVELLING - D



**BODY AND STRUCTURE - E**

CROP PROCESSING - K

**The sections used through out all New Holland product Repair manuals may not be used for each product. Each Repair manual will be made up of one or several books. Each book will be labeled as to which sections are in the overall Repair manual and which sections are in each book.**

**The sections listed above are the sections utilized for the H9870 and H9880 Bale Wagons.**

## BODY AND STRUCTURE - E

### Frame - 10

#### CONTENTS

<b>Section</b>	<b>Description</b>	<b>Page</b>
	Frames .....	2
	Torques .....	2
	Special Tools .....	4
	Introduction .....	4
	Frame Rails .....	5
	Cab Removal .....	6
	Cab Preparation .....	6

**FRAMES**

**TORQUES**

**MINIMUM HARDWARE TIGHTENING TORQUES**

**IN NEWTON-METERS (FOOT POUNDS) FOR NORMAL ASSEMBLY APPLICATIONS**

**METRIC NON-FLANGED HARDWARE AND LOCKNUTS**

NOMINAL SIZE	CLASS 5.8		CLASS 8.8		CLASS 10.9		LOCKNUT CL.8 W/CL8.8 BOLT
	UNPLATED	PLATED W/ZnCr	UNPLATED	PLATED W/ZnCr	UNPLATED	PLATED W/ZnCr	
M4	1.7 (15)*	2.2 (19)*	2.6 (23)*	3.4 (30)*	3.7 (33)*	4.8 (42)*	2.3 (20)*
M6	5.8 (51)*	7.6 (67)*	8.9 (79)*	12 (102)*	13 (115)*	17 (150)*	7.8 (69)*
M8	14 (124)*	18 (159)*	22 (195)*	28 (248)*	31 (274)*	40 (354)*	19 (169)*
M10	28 (21)	36 (27)	43 (32)	56 (41)	61 (45)	79 (58)	38 (28)
M12	49 (36)	63 (46)	75 (55)	97 (72)	107 (79)	138 (102)	66 (49)
M16	121 (89)	158 (117)	186 (137)	240 (177)	266 (196)	344 (254)	164 (121)
M20	237 (175)	307 (226)	375 (277)	485 (358)	519 (383)	671 (495)	330 (243)
M24	411 (303)	531 (392)	648 (478)	839 (619)	897 (662)	1160 (855)	572 (422)

**NOTE:** Torque values shown with \* are inch pounds.

**IDENTIFICATION  
HEX CAP SCREW AND CARRIAGE BOLTS  
CLASSES 5.6 AND UP**

MANUFACTURER'S IDENTIFICATION

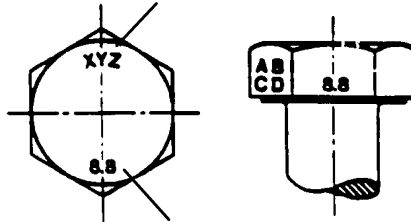

PROPERTY CLASS

**HEX NUTS AND LOCKNUTS  
CLASSES 05 AND UP**

MANUFACTURER'S IDENTIFICATION

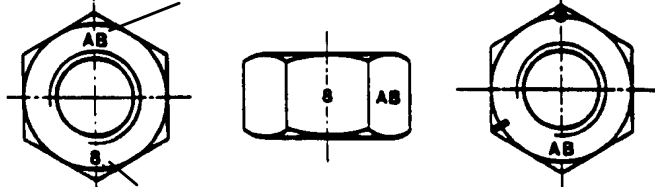

PROPERTY CLASS

CLOCK MARKING

# MINIMUM HARDWARE TIGHTENING TORQUES

IN NEWTON-METERS (FOOT POUNDS) FOR NORMAL ASSEMBLY APPLICATIONS

## INCH NON-FLANGED HARDWARE AND LOCKNUTS

NOMINAL SIZE	SAE GRADE 2		SAE GRADE 5		SAE GRADE 8		LOCKNUTS		NOMINAL SIZE
	UNPLATED or PLATED SILVER	PLATED W/ZnCr GOLD	UNPLATED or PLATED SILVER	PLATED W/ZnCr GOLD	UNPLATED or PLATED SILVER	PLATED W/ZnCr GOLD	GR.B w/GR5 BOLT	GR.C w/GR8 BOLT	
1/4	6.2 (55)*	8.1 (72)*	9.7 (86)*	13 (112)*	14 (121)*	18 (157)*	8.5 (75)*	12.2 (109)*	1/4
5/16	13 (115)*	17 (149)*	20 (178)*	26 (229)*	28 (250)*	37 (324)*	17.5 (155)*	25 (220)*	5/16
3/8	23 (17)	30 (22)	35 (26)	46 (34)	50 (37)	65 (48)	31 (23)	44 (33)	3/8
7/16	37 (27)	47 (35)	57 (42)	73 (54)	80 (59)	104 (77)	50 (37)	71 (53)	7/16
1/2	57 (42)	73 (54)	87 (64)	113 (83)	123 (91)	159 (117)	76 (56)	108 (80)	1/2
9/16	81 (60)	104 (77)	125 (92)	163 (120)	176 (130)	229 (169)	111 (82)	156 (115)	9/16
5/8	112 (83)	145 (107)	174 (128)	224 (165)	244 (180)	316 (233)	153 (113)	215 (159)	5/8
3/4	198 (146)	256 (189)	306 (226)	397 (293)	432 (319)	560 (413)	271 (200)	383 (282)	3/4
7/8	193 (142)	248 (183)	495 (365)	641 (473)	698 (515)	904 (667)	437 (323)	617 (455)	7/8
1	289 (213)	373 (275)	742 (547)	960 (708)	1048 (773)	1356 (1000)	654 (483)	924 (681)	1

NOTE: Torque values shown with \* are inch pounds.

### IDENTIFICATION CAP SCREWS AND CARRIAGE BOLTS



### LOCKNUTS

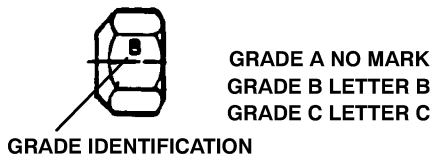
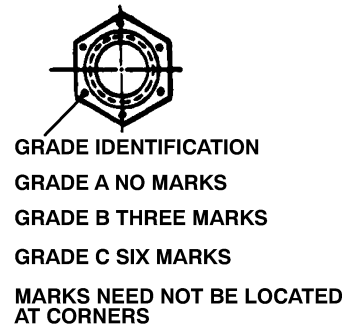
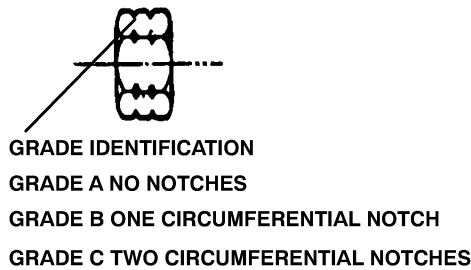

### SPECIAL TOOLS

The following special tools are required for repairing the cab on the Bale Wagons.

- Cab lifting tool
- Cab supports
- Splitting stand

### INTRODUCTION

The BW bale wagon consists of two separate frames:

The main frame

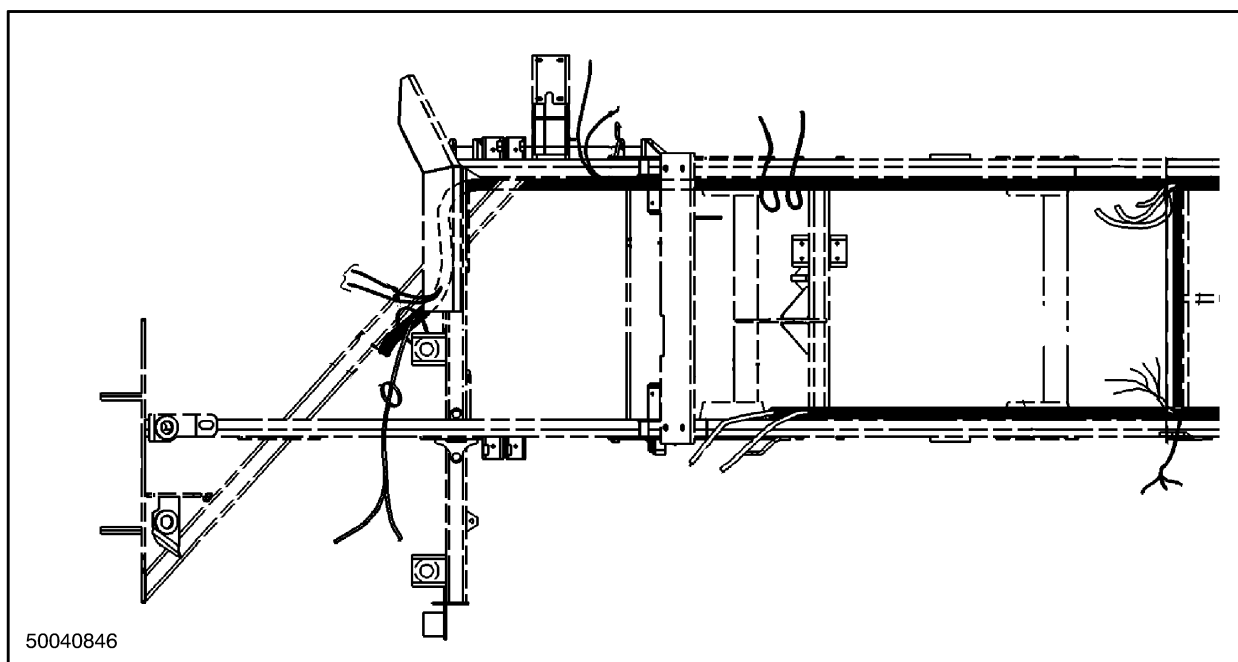

1

and the cab frame.

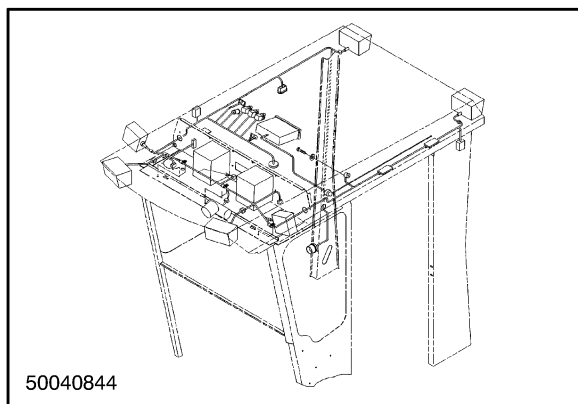

2

## BODY AND STRUCTURE - FRAME

The entire cab platform is mounted (at 1) on four rubber isolation mounts to reduce twisting, vibration and noise transmitted from the engine and drivetrain.

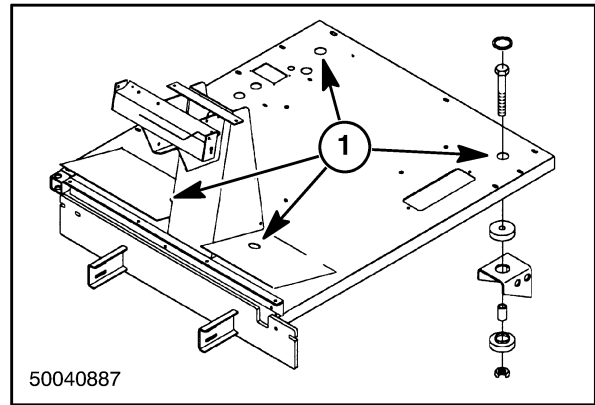

3

### FRAME RAILS

The one-piece frame channels, 1, are constructed of 3/8" steel.

The frame is a welded assembly, which uses structural tubing cross members, 2, for added strength and durability.

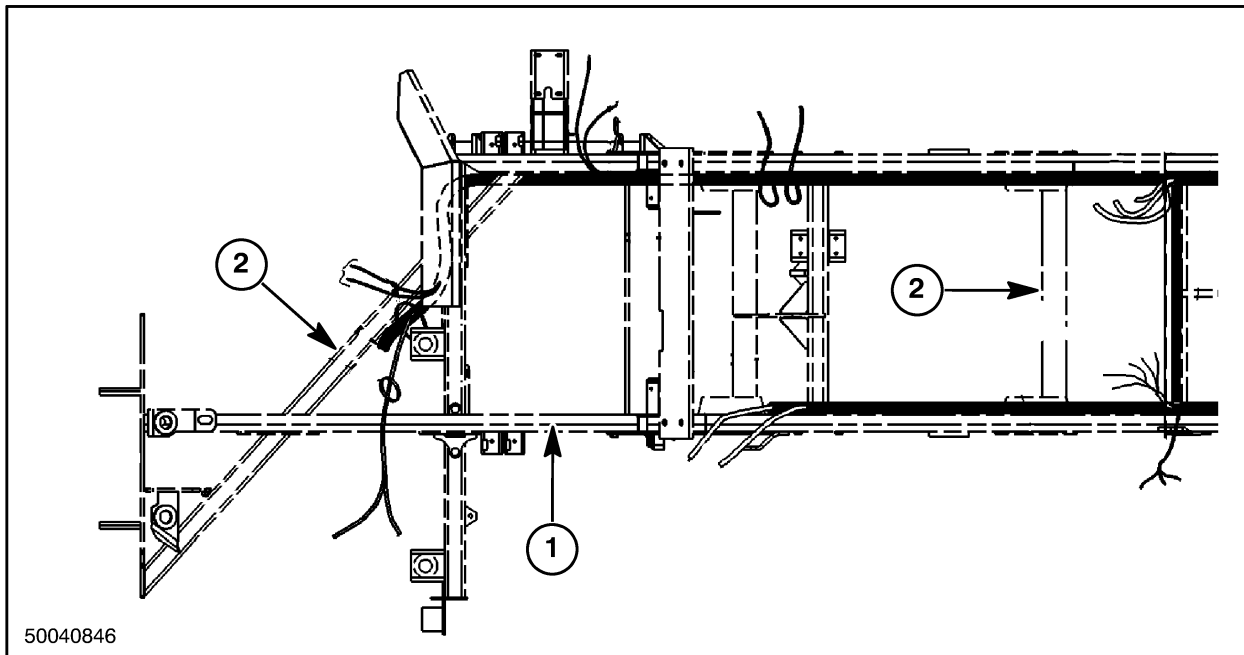

4

## CAB REMOVAL

The following procedure describes the removal and replacement of the bale wagon cab as a complete unit.

Cab removal is only necessary if major damage is apparent to the cab.

### CAB PREPARATION

1. Park the bale wagon on a level surface, set the parking brake and remove the keys from the ignition.
2. Fully raise the load rack, 1.
3. Raise the second table, 2, and engage the safety prop.

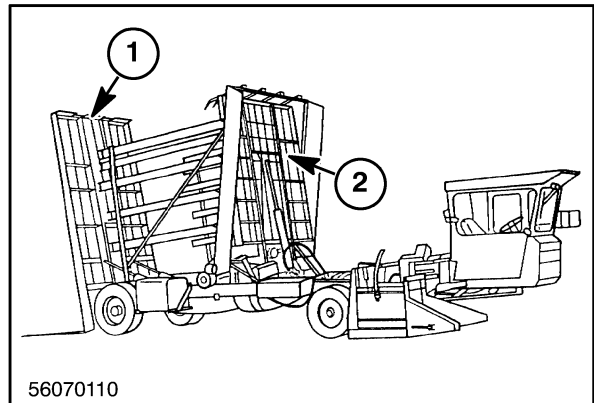

1

Whenever it is necessary to work under the second table in the raised position, engage the safety prop, 1, to support the table.



**Do not work under a raised second table unless the safety prop, 1, is raised to support the second table. Failure to comply will result in death or serious injury.**

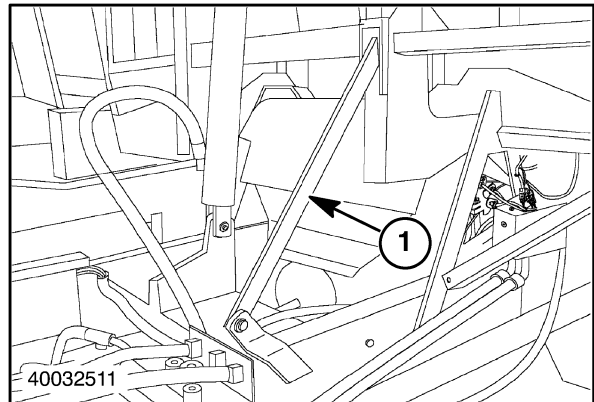

2

4. Disconnect the negative battery cable, 1.

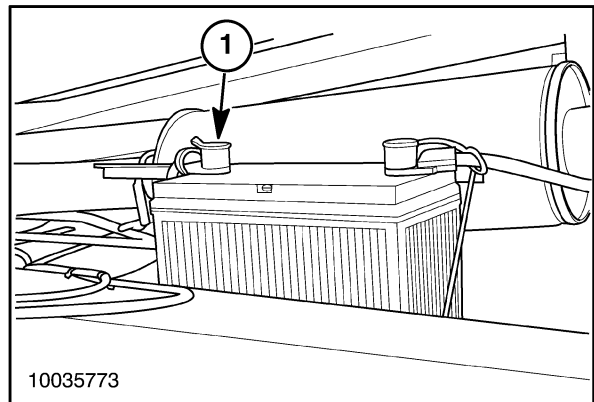

3

BODY AND STRUCTURE - FRAME

5. Remove the nut from the ground strap, 1, Remove the ground strap from the diagonal frame rail. (*ground location "4"*)

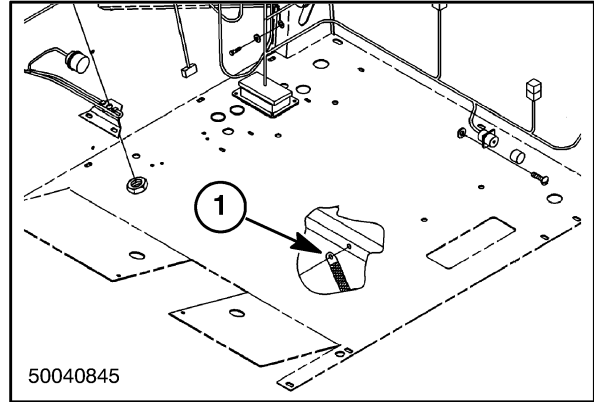

4

6. Disconnect the RC\MH connector (X010), 1.

**If the bale wagon is not equipped with a heater, continue with step 13.**

7. If equipped with a heater, remove the panels from the right console to access the heater hoses. Two heater hoses will be located at, 2. Follow steps 8 through 12.

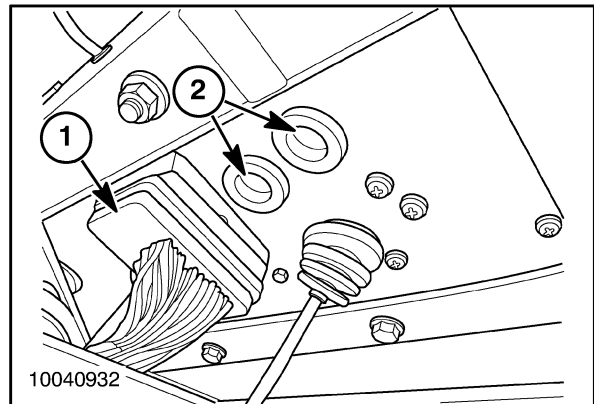

5

8. Remove six truss head screws from the left panel, 1.
9. Remove five truss head screws from the right panel, 2, including the screw, 3, securing the fuse panel lid.
10. Loosen bolt, 4, on the control handle of the MFH (S-29).

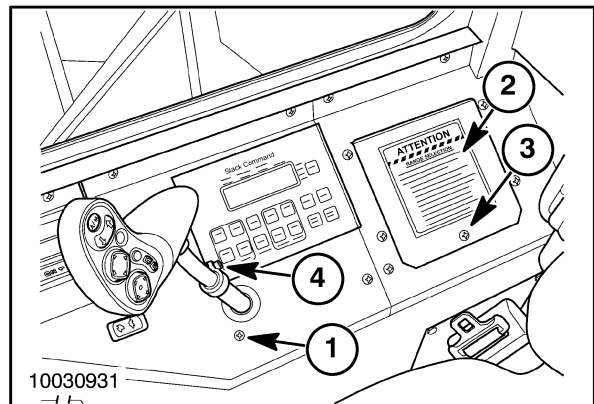

6

11. Lift the MFH (S-29), 1, up from the panel and allow it to drape over the console. *It is not necessary to remove any connections from inside the console unless specified.*

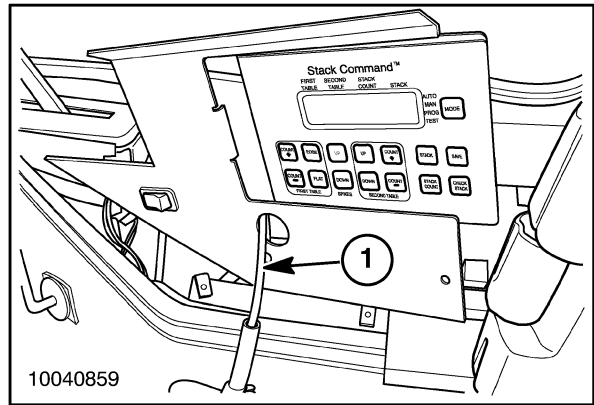

7

12. Loosen clamps, 1, from the hoses, 2, on the heater assembly, 3. Remove hoses.

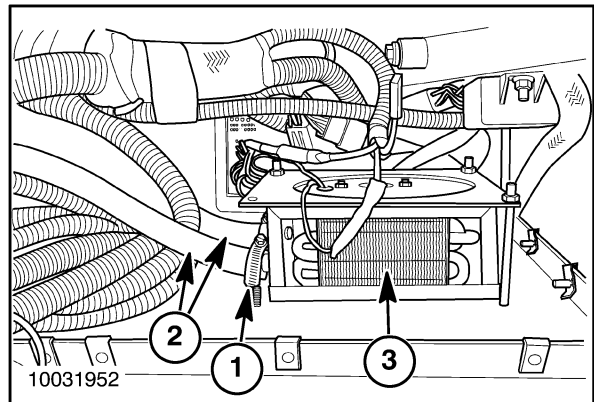

8

13. Disconnect transmission shift cable, 1, and remove cable from inside the right console.
14. Disconnect the accelerator cable, 2, from inside the right console.

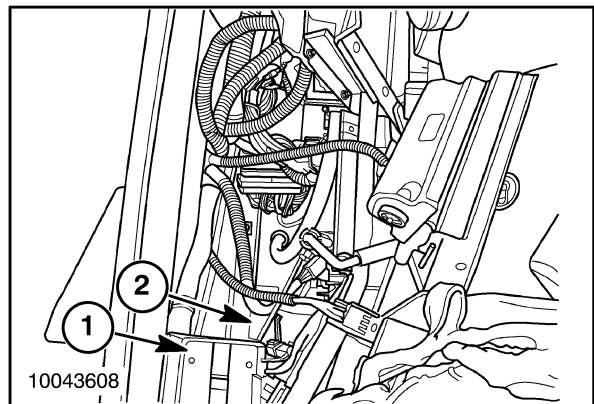

9

- Remove accelerator cable, 1, from the underside of the cab frame.

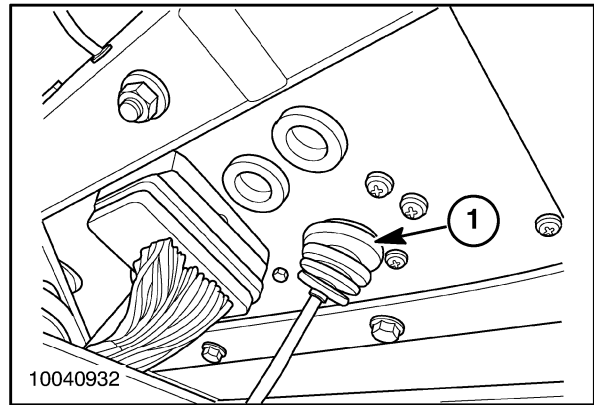

10

**⚠ WARNING ⚠**

**Fully recover any refrigerant before disconnecting any lines or components. Wear gloves and eye protection when opening refrigerant lines or fittings. Failure to comply could cause death or serious injury.**

- Recover all refrigerant from the air conditioning system. See Section E, Chapter 40 – Environment Control, for procedure.
- Disconnect wires MH262 and MH240 from the high-pressure switch (S-15), 1, at connectors, 2, (X089) and (X236) connecting to the MH wire harness.

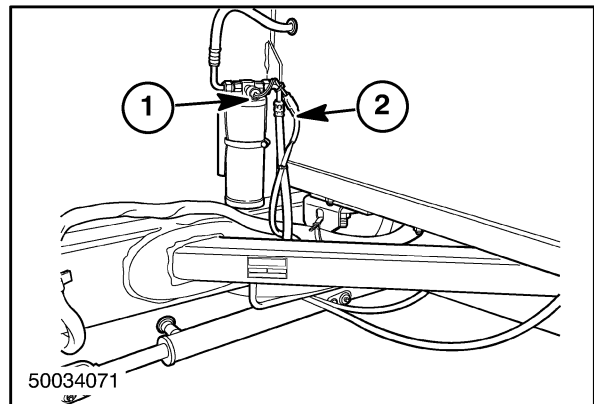

11

- Remove the inlet, 1, and outlet line, 2, from the receiver/drier canister. Cap both lines.

**IMPORTANT:** Cap and plug all fittings and hoses opened during disassembly to prevent dirt from entering the system.

- Remove the retaining band, 3, that secures the receiver/drier canister to the cab frame.
- Remove the canister from the side of the cab.

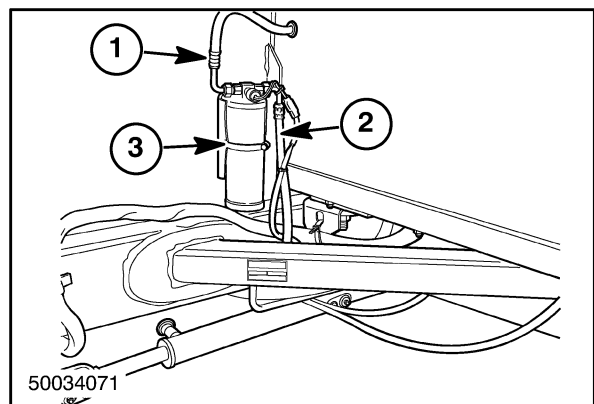

12

21. Remove five truss head screws from the bottom skirt, 1, located on the left side of the cab.

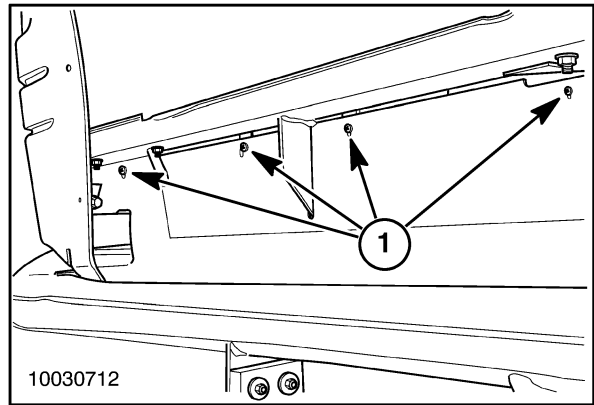

13

22. Disconnect the first table left trip sensor (B-08) connector (X155), 1, located behind the brake boost motor (M-05), 2.

23. Cut cable ties, 3. Do not remove the wire harness until the brake boost motor (M-05) is disconnected.

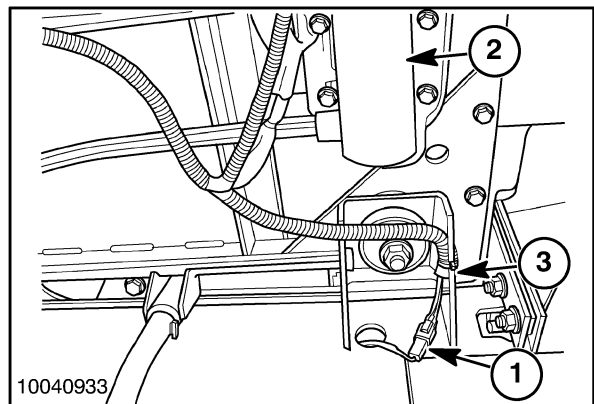

14

24. Disconnect the brake flow switch (S-23), 1, connector (X114) from the motor (M-05).

25. Disconnect the brake linkage, 2, at the brake boost motor (M-05).

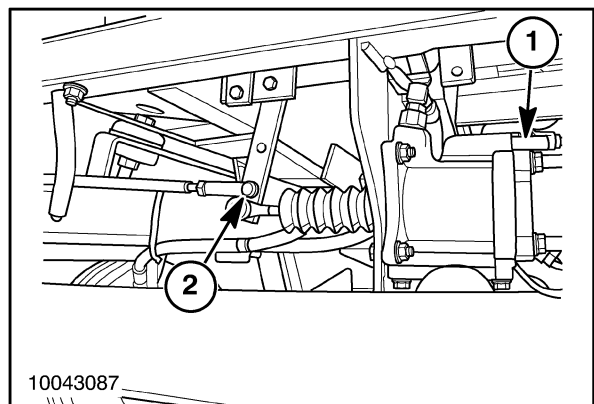

15

26. Disconnect the linkage, 1, from the brake pedal.  
(behind the front fender) Remove linkage.

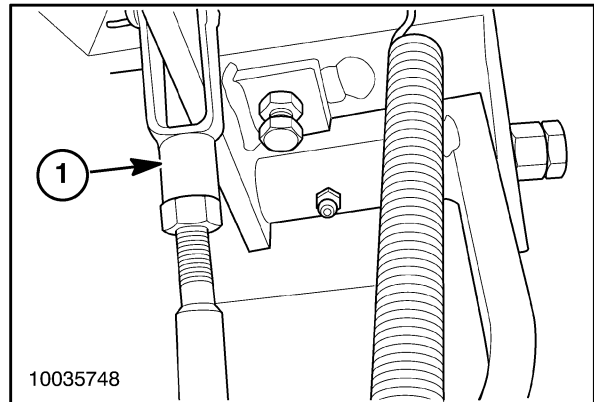

16

27. Remove the ground wire, 1, from the motor (M-05) housing, 2.  
28. Disconnect the brake boost relay (K-17) connector, 3, (X103).

Brake Boost Motor Relay (K-17)			
Cav	Wire	Color	Gauge
30	MH-286	Red	3.0
85	MH-288	Yellow	0.8
86	MH-387	Yellow	0.8
87	MH-289	Red	3.0

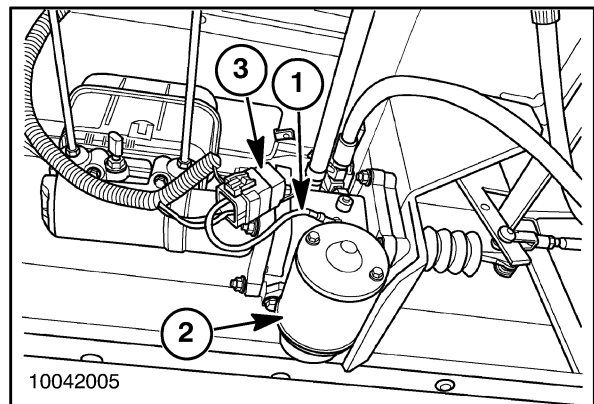

17

29. Cut all remaining wire ties and remove the wire harness from underneath the cab.

⚠ **WARNING** ⚠

**WARNING!** Be sure all system hydraulic pressure has been depleted. Never remove a brake line or hose under pressure. Failure to comply could cause death or serious injury.

**NOTE:** Tag all hydraulic lines for ease of reassembly and plug all lines to protect the system from contaminants.

30. Disconnect front brake fluid line, 1, and rear brake fluid line, 2, from the master cylinder. Cap or plug all lines.

**NOTE:** Replace O rings at fittings whenever fittings are removed for servicing.

31. Disconnect hydraulic inlet, 3, and return, 4, hoses from the brake booster. Cap or plug all lines.

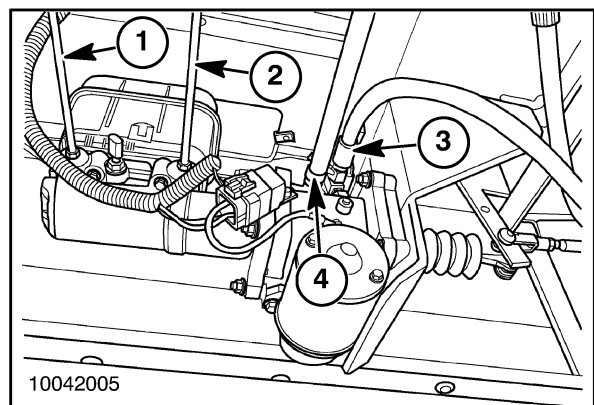

18

32. Remove steering arm, 1, from the steering motor.
33. Tag and disconnect the hydraulic lines, 2, from the steering motor, 3.
34. Cut any tie wraps that may interfere with the steering lines being removed.

**NOTE:** Cap and plug all hydraulic lines and ports once they have been disconnected.

See Section D, Chapter 20 – STEERING SYSTEM for disassembly instructions.

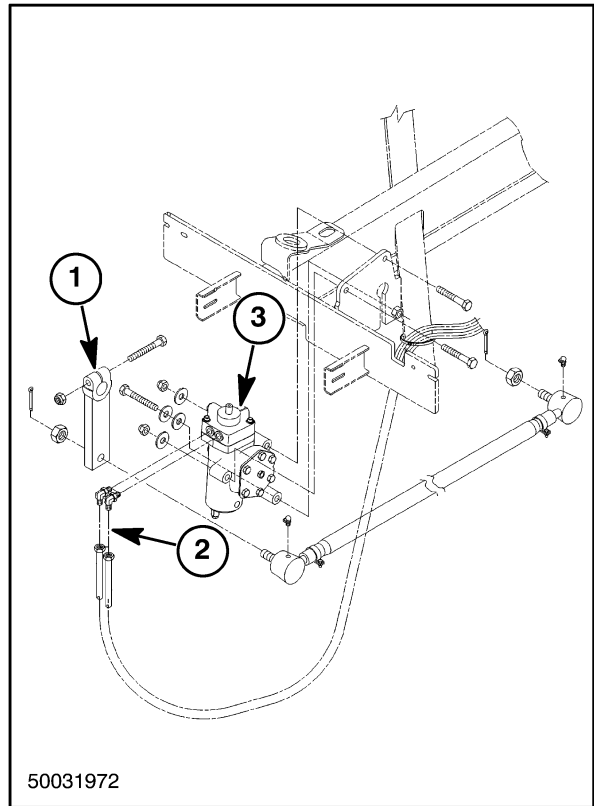

19

35. Remove steering components from the flexible coupling, 1, to the wheel.

See Section D, Chapter 20 – STEERING SYSTEM for disassembly instructions.

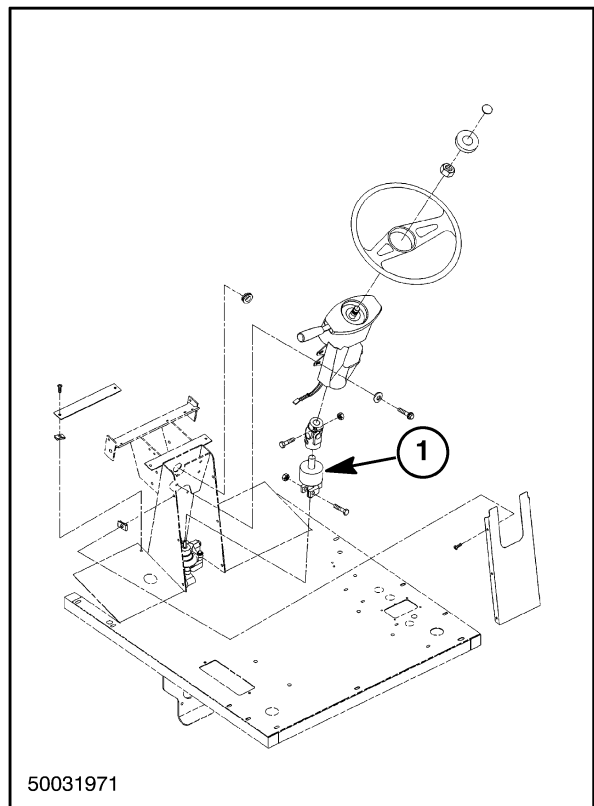

20

36. Remove seat assembly from the seat base, 1.

**NOTE:** Cab seat is very heavy. Use a proper lifting device or a partner to remove the seat assembly from the cab.

Please refer to Section E, Chapter 32 – User Controls and Seat for seat removal.

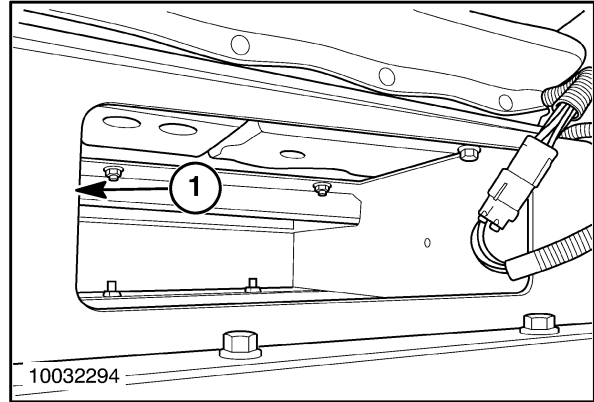

21

37. Loosen nuts, 1, from the four isolation mounts and remove bolts.

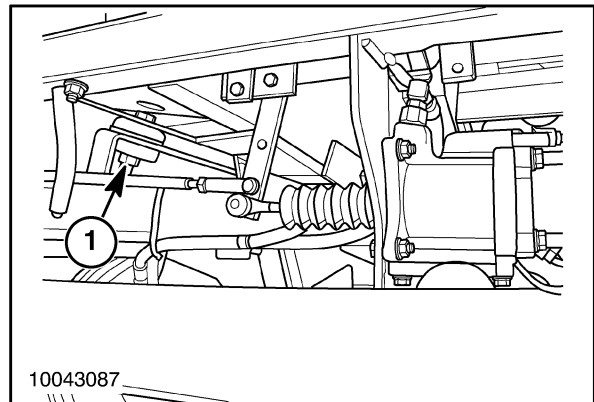

22

38. Attach an adequate lifting device to the cab frame.

39. Remove the cab frame from the main frame.



## BODY AND STRUCTURE - E

### Shield - 20

#### CONTENTS

<b>Section</b>	<b>Description</b>	<b>Page</b>
	Protective Shields .....	2
	Engine Shield .....	2
	Removal .....	2
	Front Shield .....	2
	Removal .....	2
	Left-Hand Bumper .....	3
	Removal .....	3
	Rear Window Guard .....	4
	Removal .....	4
	Radiator Screen Door .....	4
	Access to Components .....	4
	Removal .....	5

## PROTECTIVE SHIELDS

### ENGINE SHIELD

#### Removal

1. Remove four nuts, 1, from the shield, 2, attaching to bracket on front of engine. Remove shield.

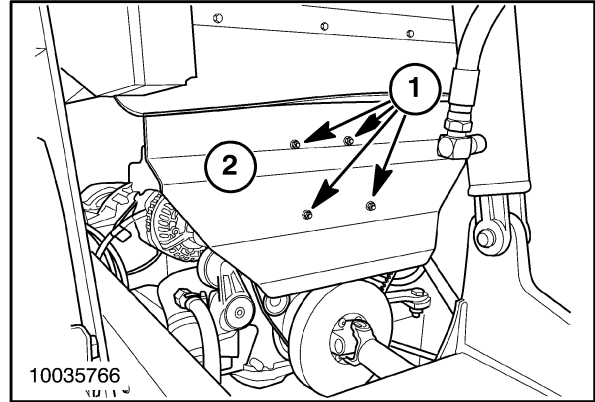

1

### FRONT SHIELD

#### Removal

1. Remove four flange head screws, 1, from the front of the shield attaching to the headlight brackets.

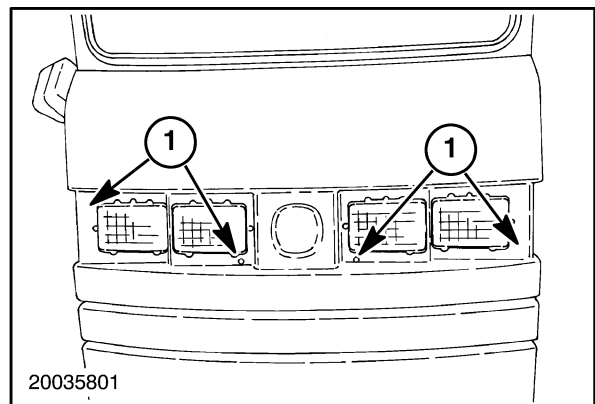

2

2. Remove three pan head screws, 1, from each side of the shield.
3. Remove shield.

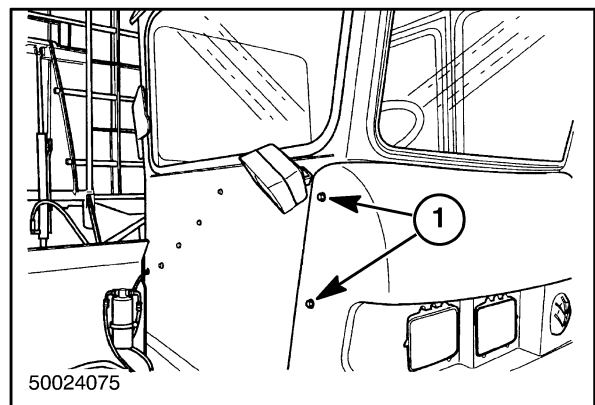

3

**LEFT-HAND BUMPER**

**Removal**

1. Remove two cap screws, 1, and two flange nuts from underneath cab frame. (*left side shown*)
2. Remove two flange nuts, 2, and two cap screws.
3. Repeat steps one and two for the right-hand side.

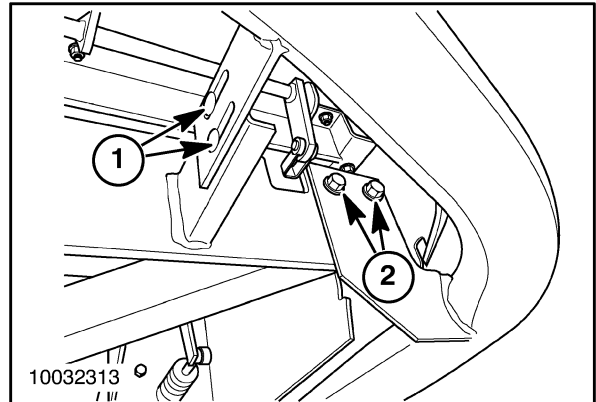

4

4. Pull bumper, 1, from mount, 2.

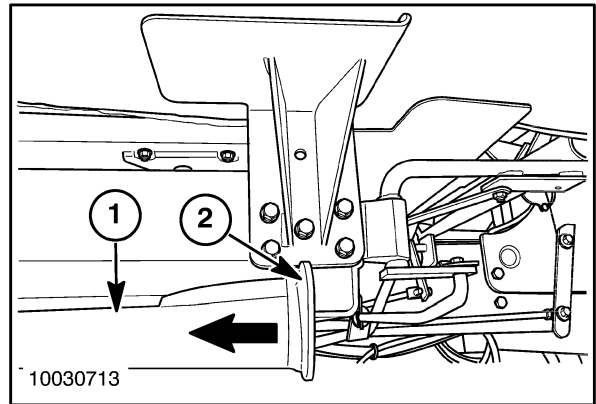

5

5. Remove from mount, 1.

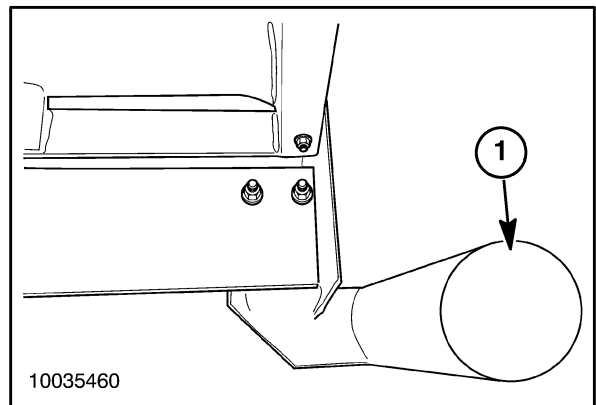

6

## REAR WINDOW GUARD

### Removal

1. Remove four carriage bolts, 1, lock nuts, and lock washers from the guard attaching to the rear of the cab.
2. Remove guard.

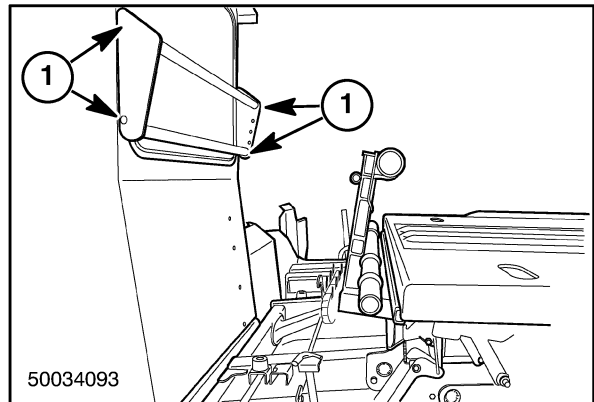

7

## RADIATOR SCREEN DOOR

### Access to Components

1. Unlatch the two rubber latches located on the right-hand side of the radiator door.
2. Open radiator door, 2.

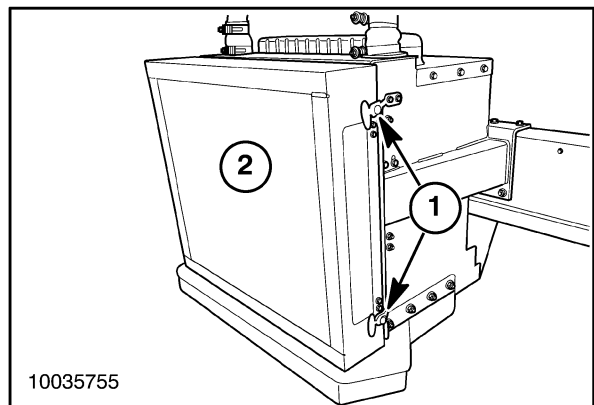

8

When the radiator screen door, 1, is open, access to the air conditioner condenser, 2, and the intercooler, 3, are exposed.

See section E, Chapter 40 – Air Conditioning System, for inspection, removal and repairs.

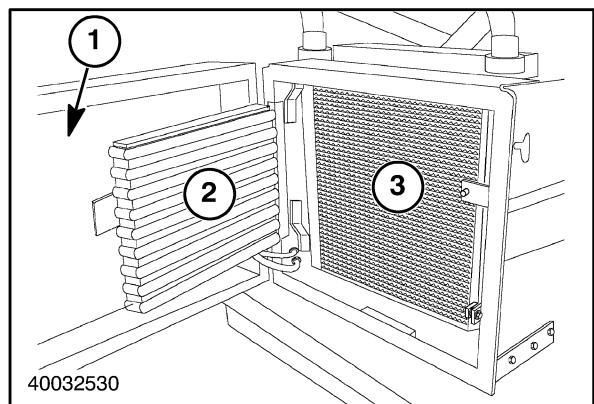

9

**Removal**

1. Loosen two nuts, 1, from the top and bottom hinges located on the left-hand side of the radiator door.
2. Remove the two hex bolts, 2, from the hinges.
3. Remove the radiator door.

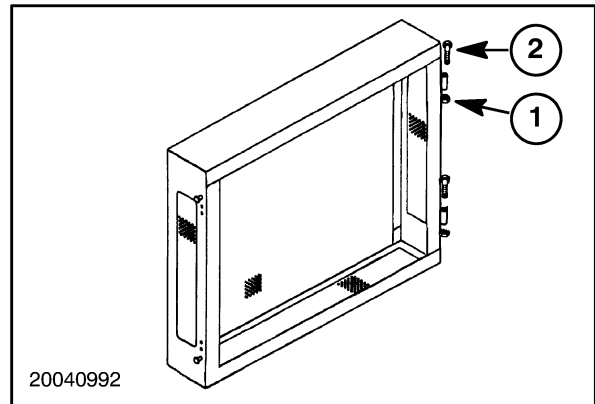



**BODY AND STRUCTURE - E**

**User Controls and Seat - 32**

		CONTENTS	
Section	Description		Page
	Operator's Seat .....		4
	Controls .....		4
	Armrest Height .....		4
	Height Adjustment .....		4
	Backrest .....		4
	Swivel .....		4
	Fore/Aft Position .....		4
	Lumbar Adjustment .....		5
	Seat Belt .....		5
	Cleaning .....		5
	Replacing .....		5
	Seat .....		6
	Removing the Seat from the Seat Base .....		6
	Removing the Seat Base from the Floor .....		6
	Disassembly .....		7
	Armrest .....		7
	Removal .....		7
	Adjustment .....		8
	Height Adjustment Switch .....		10
	Replacement .....		10
	Bottom Seat Cushion .....		11
	Removal .....		11
	Seat Back Cushion .....		11
	Removal .....		11
	Upper Seat from Swivel .....		12
	Removal .....		12
	Seat Swivel and Forward/Aft Adjustment Rails .....		13
	Removal .....		13
	Seat Swivel .....		13
	Disassembly .....		13
	Inspection .....		14
	Slide Rails from Suspension .....		14
	Removal .....		14

<b>Section</b>	<b>Description</b>	<b>Page</b>
	Seat Suspension System .....	15
	Seat Air Compressor .....	15
	Height Adjustment .....	15
	Circuit Description .....	16
	Troubleshooting .....	18
	Seat Suspension .....	19
	Disassembly .....	19
	Rubber Bumpers .....	22
	Inspection .....	22
	Release Valve/ Solenoid .....	22
	Inspection .....	22
	Air Compressor .....	23
	Inspection .....	23
	Fore/Aft Adjustment Lever .....	24
	Inspection .....	24
	Damping Shock Absorber .....	24
	Inspection .....	24
	Scissors Suspension .....	25
	Inspection .....	25
	Mirrors .....	25
	Inside Rearview Mirror .....	25
	Replacement .....	25
	Outside Rearview Mirror .....	25
	Mirror Replacement .....	25
	Mirror Bracket Replacement .....	25
	Right-hand Console .....	26
	Controls .....	26
	Fuse Panel .....	27
	Replacement .....	28
	Component Chart .....	29
	User Controls Wire Harness Connection Information .....	30
	RC Wire Harness Connections .....	30
	OI Wire Harness Connections .....	31
	Audio System .....	33
	Radio (If Equipped) .....	33
	Circuit Description .....	33
	Speakers .....	35
	Troubleshooting .....	36

BODY AND STRUCTURE - USER CONTROLS AND SEAT

---

<b>Section</b>	<b>Description</b>	<b>Page</b>
	Overhead Console .....	39
	Climate Control Panel .....	39
	Controls .....	39
	Auxiliary Plug .....	41
	Removal/Replacement .....	41
	Center Panel .....	42
	Cab Vent Panel .....	42
	Air Filter .....	42
	Removing/Cleaning .....	42
	Instrument Panel .....	43
	Controls .....	43
	Removal .....	44
	Instrument Panel Wire Connections .....	45
	Fuel Gauge (E-12) .....	46
	Voltmeter (E-16) .....	46
	Water Temperature Gauge (E-29) .....	46
	Engine Oil Pressure Gauge (E-13) .....	47
	Tachometer/Hourmeter (E-14) .....	47
	Tachometer/Calibration .....	47
	Speedometer/Odometer (E-03) .....	48
	Speedometer Calibration .....	48
	Ignition Key Switch (S-13) .....	48
	Instrument Gauge .....	49
	Replacement .....	49
	Bulb .....	49
	Replacement .....	49
	Ignition Key Switch .....	50
	Replacement .....	50
	Instrument Panel Troubleshooting .....	51
	All Gauges Do Not Power On .....	51
	Speedometer (E-03) Does Not Work Correctly .....	52
	Tachometer (E-14) .....	53
	Tachometer/Hourmeter (E-14) Does Not Work Correctly. ....	53
	Coolant Temperature Gauge (E-29) Does Not Work Correctly .....	54
	Voltmeter (E-16) Does Not Work Correctly .....	54
	Fuel Gauge (E-12) Does Not Work Correctly .....	55
	Oil Pressure Gauge (E-13) Does Not Work Correctly .....	56
	Indicator Light Tower .....	56

## OPERATOR'S SEAT

### CONTROLS

#### Armrest Height

Rotate knob, 1, up to raise armrest. Rotate knob, 1, down to lower.

**NOTE:** Armrests will adjust at an angle of 23° up and 12° down from position shown.

#### Height Adjustment

To adjust seat height, key switch (S-13) must be in the ON position.

Push height control switch, 2, up to raise. Release when desired height is reached.

Push height control switch, 2, down to lower. Release when desired height is reached.

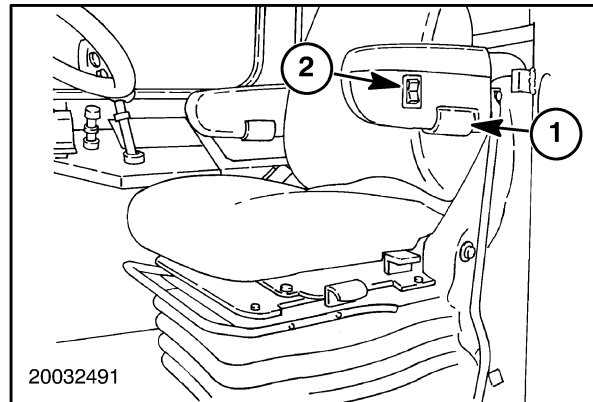

#### Backrest

Lift lever, 3, and tilt backrest until desired position is reached. Release lever to lock backrest in position.

**NOTE:** Backrest tilt adjusts 21° forward and 33° rearward.

#### Swivel

Lift lever, 4, and rotate seat. Release lever, 4, and rotate the seat until it locks in one of the preset positions.

**NOTE:** Swivel rotates and locks in one position to the left and three positions to the right in 7° increments.

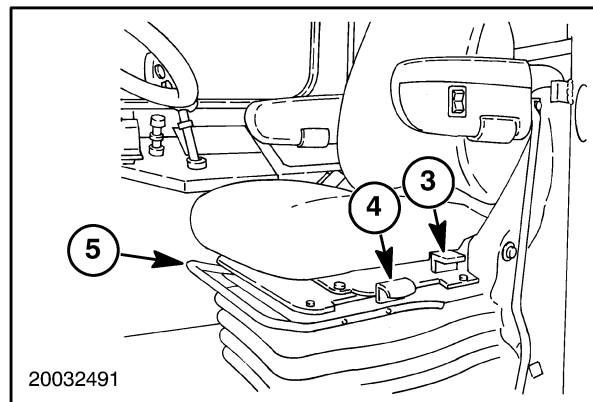

#### Fore/Aft Position

Pull up on handle, 5, and move seat forward or backward to the desired position. Release the handle, 5, to lock the seat in position.

**NOTE:** Total adjustment is 160 mm (6.3") in 10 mm (0.4") increments.

### Lumbar Adjustment

Rotate knob, 1, up to add more support. Rotate knob, 1, down for less support.

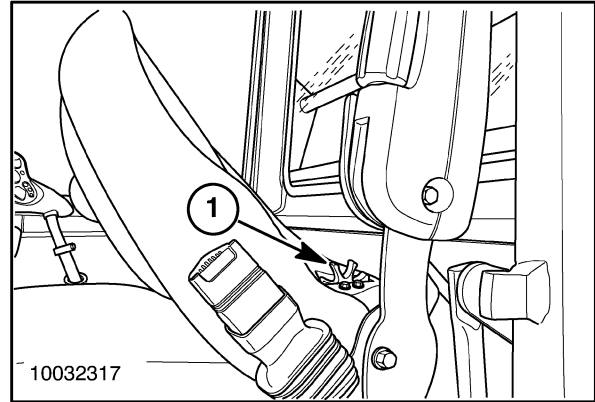

3

### SEAT BELT

The Bale Wagon is equipped with a retractable seat belt that automatically adjusts to the person in the seat.

#### Cleaning

Use soapy water to clean belt. Do not use solvents, bleach, or dye.

#### Replacing

Replace belt when signs of fraying, damage, or wear appear.

1. Remove hex head bolt and two flat washers, 1, from the male end of seat belt. (right-hand)
2. Remove hex head bolt and two flat washers, 2, from the female end of seat belt. (left-hand)
3. Install new seat belt and attach in reverse manner.

**NOTE:** Weld nuts are located inside the seat frame. If necessary to access, simply pry bottom seat cushion from seat frame by hand and lift. Seat cushion will snap back into place.

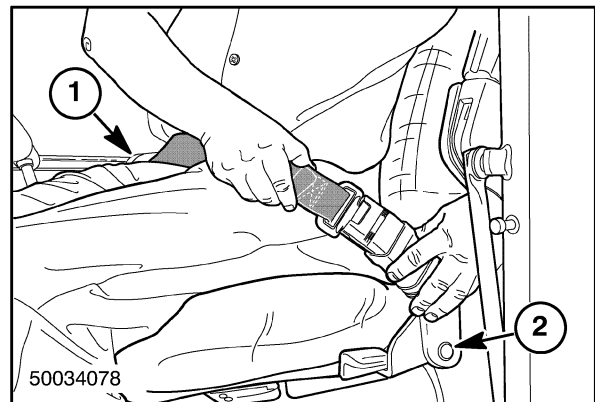

4

## SEAT

### Removing the Seat from the Seat Base



The seat is heavy and will require two people or a lifting device to remove from the cab. Weight range: 49.89 – 136.07 kg (110 – 300 lbs.). Failure to comply could result in moderate injury.

1. Remove the four bolts, 1, from the seat attaching to the seat base.
2. Disconnect the seat wire harness, 2, at the rear of the seat.

**NOTE:** Before removing the seat from the cab, tilt steering wheel to forward position for more clearance.

3. Remove the seat assembly from the cab using a proper lifting device.

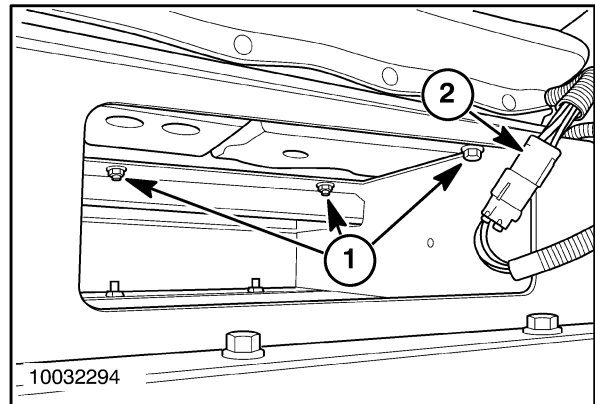

5

### Removing the Seat Base from the Floor

1. Remove two bolts, 1, from left side of the seat base.
2. Loosen two nuts, 2, from right side of the seat base.

**NOTE:** Bolt heads are accessible from underneath the cab frame.

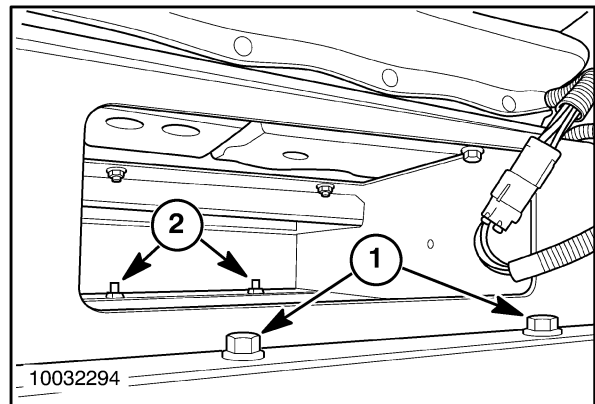

6

**Disassembly**

The complete seat assembly will be dismantled into three operating components. Each component is then disassembled, inspected, and reassembled to one another.

— **⚠ CAUTION ⚠** —

**The seat is heavy and will require two people or a lifting device to remove from the cab. Weight range: 49.89 - 136.07 kg (110 - 300 lbs.). Failure to comply could result in moderate injury.**

The three operating components are as follows:

1. **Upper seat** (back, cushion, seat belt, armrests).
2. **Seat swivel and forward/aft adjustment rails.**
3. **Seat suspension.**

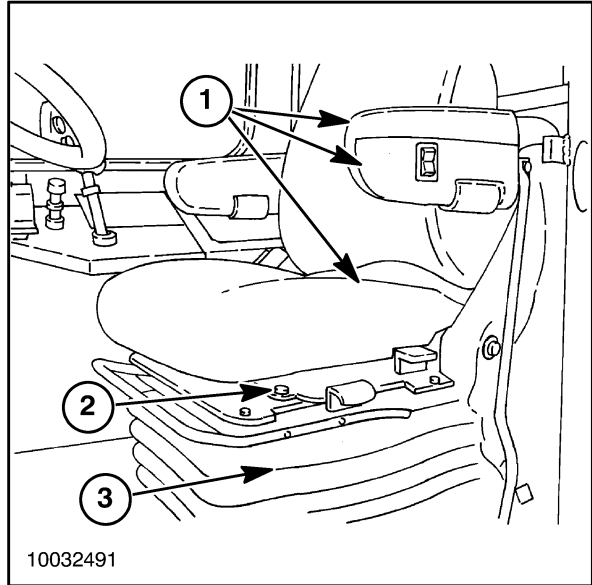

7

**ARMREST**

**Removal**

1. Remove pan head screw, 1, from underside of armrest.
2. Remove top half, 2, of armrest for access to nut and washer.

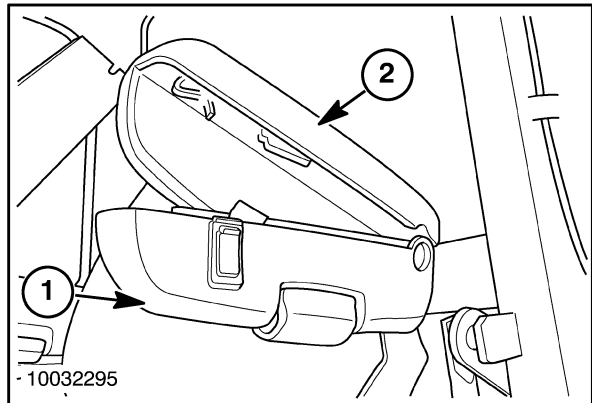

8

3. If applicable, disconnect and remove height adjustment switch (S-28), 1.

**NOTE:** If repair is made on the left-hand armrest, follow procedure for replacing the height adjustment switch.

4. Remove flange head bolt, 2, flat washer, and nut, 3, from the armrest attaching to the frame.

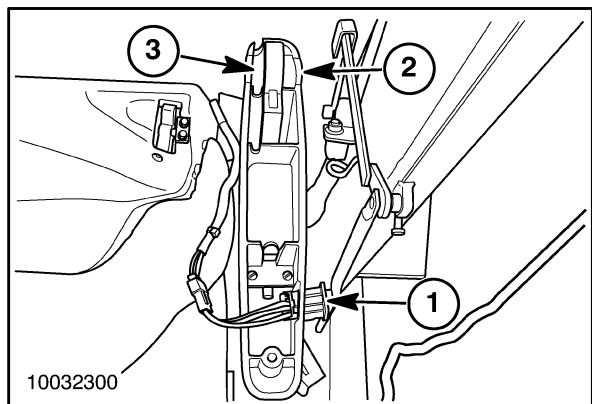

9

**Adjustment**

- 1. Height adjustment knob
- 2. Threaded rod w/ nut
- 3. Retaining plate
- 4. Two machine screws

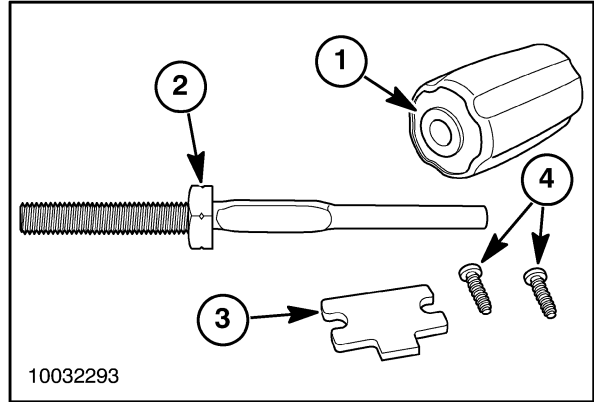

10

- 1. Remove pan head screw, 1, from underside of armrest.
- 2. Separate the top half of armrest, 2, from the bottom half that is bolted to the seat frame.

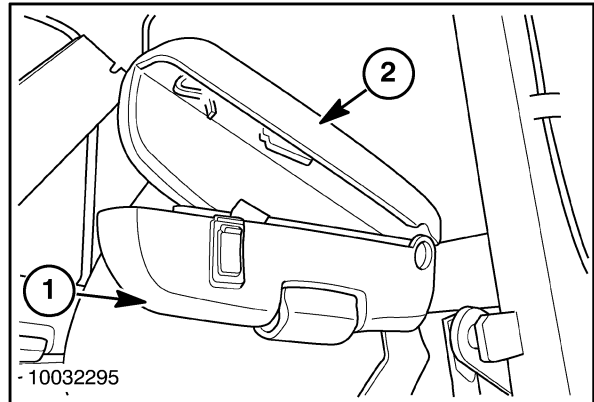

11

- 3. Remove two machine screws, 1, from retaining plate.

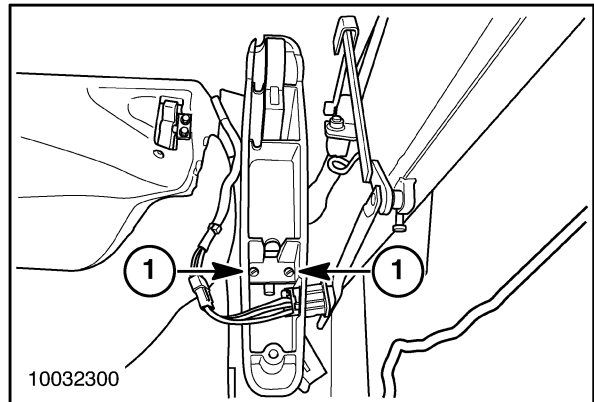

12