



# YAMAHA

# '84

# RD500LC

## SERVICE MANUAL MANUEL D'ATELIER WARTUNGSANLEITUNG

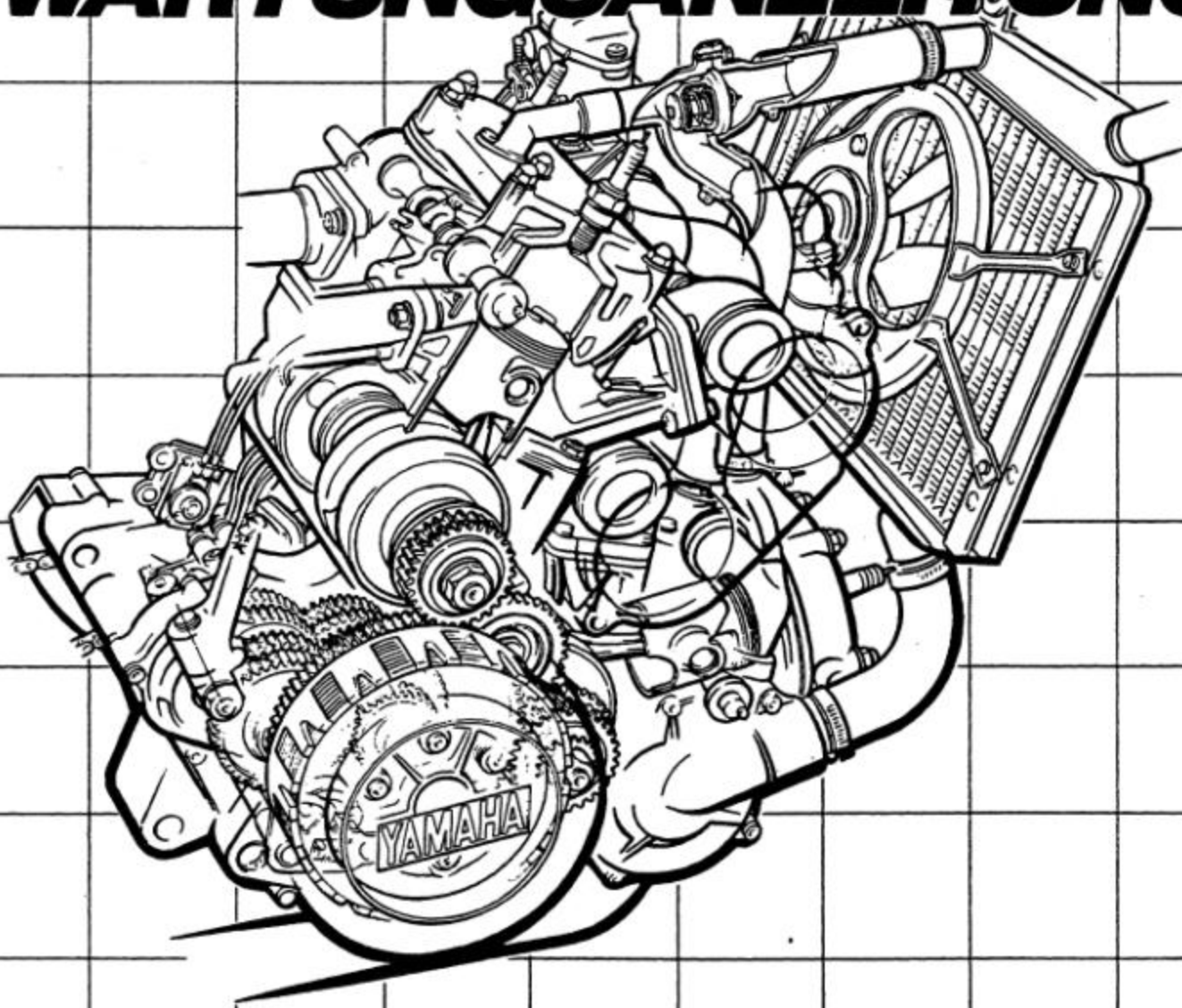

Product: 1984 Yamaha RD500LC Motorcycle Service Repair Workshop Manual  
Full Download: <https://www.arepairmanual.com/downloads/1984-yamaha-rd500lc-motorcycle-service-repair-workshop-manual/>

Sample manual. Download All pages at:  
<https://www.arepairmanual.com/downloads/1984-yamaha-rd500lc-motorcycle-service-repair-workshop-manual/>

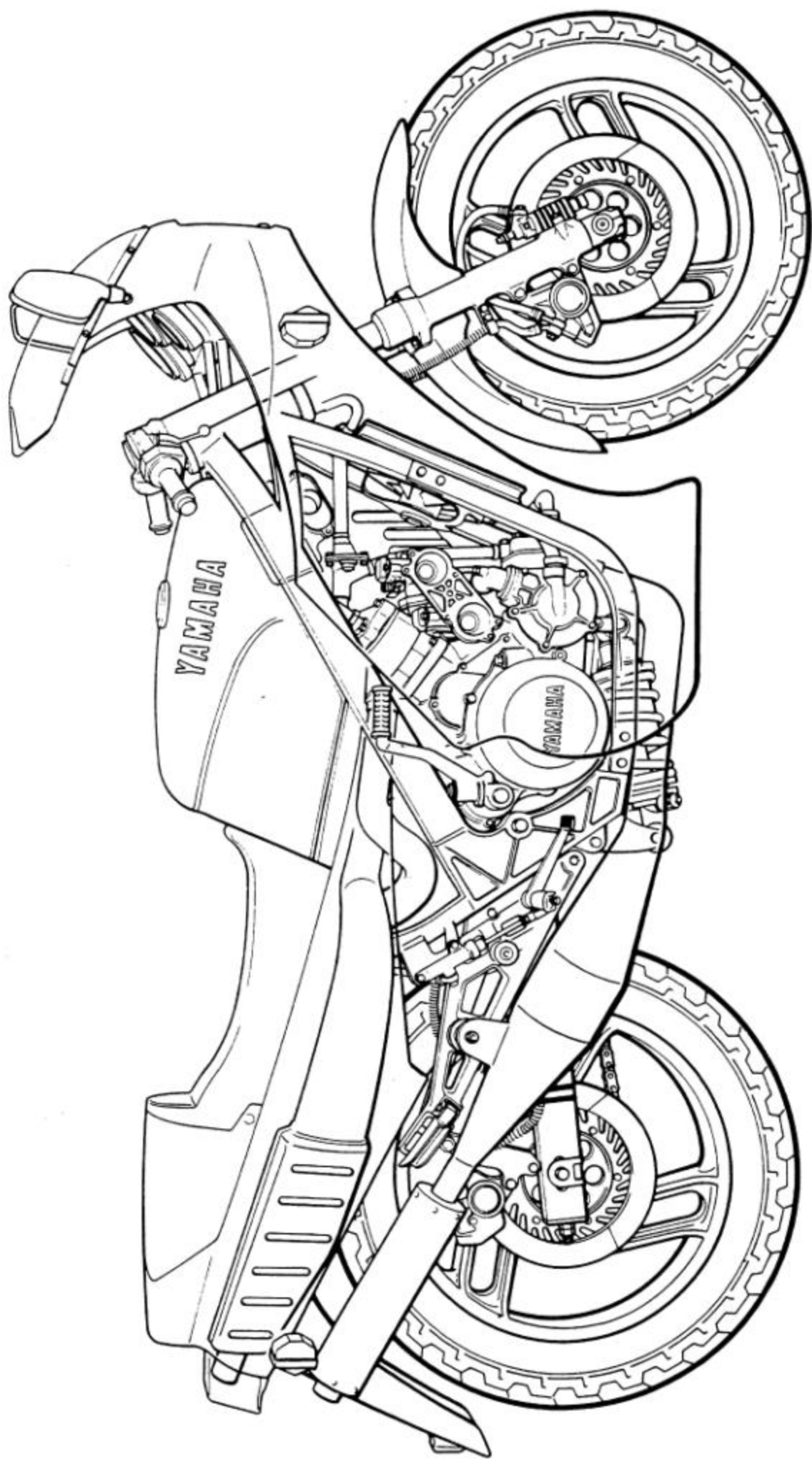



---

## NOTICE

This manual was written by the Yamaha Motor Company primarily for use by Yamaha dealers and their qualified mechanics. It is not possible to put an entire mechanic's education into one manual, so it is assumed that persons using this book to perform maintenance and repairs on Yamaha motorcycles have a basic understanding of the mechanical concepts and procedures inherent in motorcycle repair technology. Without such knowledge, attempted repairs or service to this model may render it unfit to use and/or unsafe.

Yamaha Motor Company, Ltd. is continually striving to improve all models manufactured by Yamaha. Modifications and significant changes in specifications or procedures will be forwarded to all Authorized Yamaha dealers and will, where applicable, appear in future editions of this manual.

OVERSEAS SERVICE  
OVERSEAS OPERATIONS  
YAMAHA MOTOR CO., LTD.

## HOW TO USE THIS MANUAL

### PARTICULARLY IMPORTANT INFORMATION

This material is distinguished by the following notation.

**NOTE:** A NOTE provides key information to make procedures easier or clearer.

**CAUTION:** A CAUTION indicates special procedures that must be followed to avoid damage to the motorcycle.

**WARNING:** A WARNING indicates special procedures that must be followed to avoid injury to a motorcycle operator or person inspecting or repairing the motorcycle.

### MANUAL FORMAT

















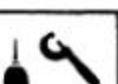



All of the procedures in this manual are organized in a sequential, step-by-step format. The information has been compiled to provide the mechanic with an easy to read, handy reference that contains comprehensive explanations of all disassembly, repair, assembly, and inspection operations.

In this revised format, the condition of a faulty component will precede an arrow symbol and the course of action required will follow the symbol, e.g.,

- Bearings  
Pitting/Damage → Replace.

### EXPLODED DIAGRAM

Each chapter provides exploded diagrams before each disassembly section for ease in identifying correct disassembly and assembly procedures.

① GEN INFO 	② INSP ADJ 	
③ ENG 	④ COOL 	
⑤ CARB 	⑥ CHAS 	
⑦ ELEC 	⑧ APPX 	
⑨ 	⑩ 	
⑪ 	⑫ 	
⑬ 	⑭ 	
⑮ 	⑯ 	⑰ 
⑱ 	⑲ 	⑳ 
㉑ 		

## ILLUSTRATED SYMBOLS (Refer to the illustration)

Illustrated symbols ① to ⑧ are designed as thumb tabs to indicate the chapter's number and content.

- ① General information
- ② Periodic inspection and adjustment
- ③ Engine
- ④ Cooling system
- ⑤ Carburetion
- ⑥ Chassis
- ⑦ Electrical
- ⑧ Appendices









Illustrated symbols ⑨ to ⑭ are used to identify the specifications appearing in the text.

- ⑨ Filling fluid
- ⑩ Lubricant
- ⑪ Tightening
- ⑫ Wear limit, clearance
- ⑬ Engine speed
- ⑭  $\Omega$ , V, A

Illustrated symbols ⑮ to ㉑ in the exploded diagram indicate grade of lubricant and location of lubrication point.

- ⑮ Apply engine oil
- ⑯ Apply gear oil
- ⑰ Apply molybdenum disulfide oil
- ⑱ Apply wheel bearing grease
- ⑲ Apply lightweight lithium-soap base grease
- ⑳ Apply molybdenum disulfide grease
- ㉑ Apply locking agent (LOCTITE®)

# INDEX

<b>GENERAL INFORMATION</b>	 GEN INFO <b>1</b>
<b>PERIODIC INSPECTIONS AND ADJUSTMENTS</b>	 INSP ADJ <b>2</b>
<b>ENGINE OVERHAUL</b>	 ENG <b>3</b>
<b>COOLING SYSTEM</b>	 COOL <b>4</b>
<b>CARBURETION</b>	 CARB <b>5</b>
<b>CHASSIS</b>	 CHAS <b>6</b>
<b>ELECTRICAL</b>	 ELEC <b>7</b>
<b>APPENDICES</b>	 APPX <b>8</b>



---

## CHAPTER 1. GENERAL INFORMATION

<b>MOTORCYCLE IDENTIFICATION</b> .....	1-1
FRAME SERIAL NUMBER .....	1-1
ENGINE SERIAL NUMBER .....	1-1
<b>IMPORTANT INFORMATION</b> .....	1-3
ALL REPLACEMENT PARTS .....	1-3
GASKETS, OIL SEALS, AND O-RINGS .....	1-3
LOCK WASHERS/PLATES AND COTTER PINS .....	1-3
BEARINGS AND OIL SEALS .....	1-3
CIRCLIPS .....	1-5
<b>SPECIAL TOOLS</b> .....	1-5
FOR TUNE-UP .....	1-5
FOR ENGINE SERVICE .....	1-7
FOR CHASSIS SERVICE .....	1-9
FOR ELECTRICAL COMPONENTS .....	1-11
<b>OPTIONAL PARTS</b> .....	1-11



**GENERAL  
INFORMATION**

**MOTORCYCLE IDENTIFICATION**

**FRAME SERIAL NUMBER**

The frame serial number ① is stamped into the right side of the steering head pipe.



**ENGINE SERIAL NUMBER**

The engine serial number ① is stamped into the elevated part of the left rear section of the engine.

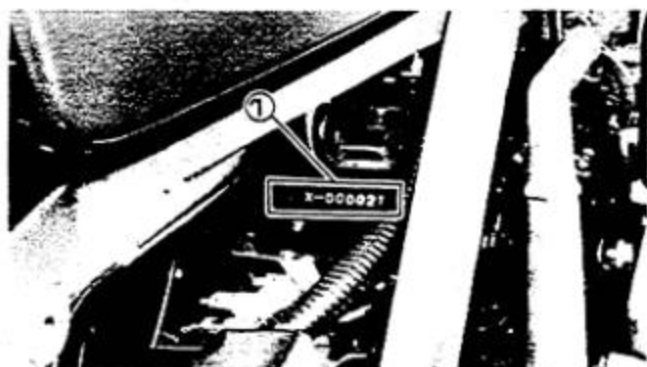

**NOTE:** \_\_\_\_\_

The first three digits of these numbers are for model identifications; the remaining digits are the unit production number.

**Starting Serial Number:**  
RD500LC . . . . .47X-000101

**NOTE:** \_\_\_\_\_

Designs and specifications are subject to change without notice.

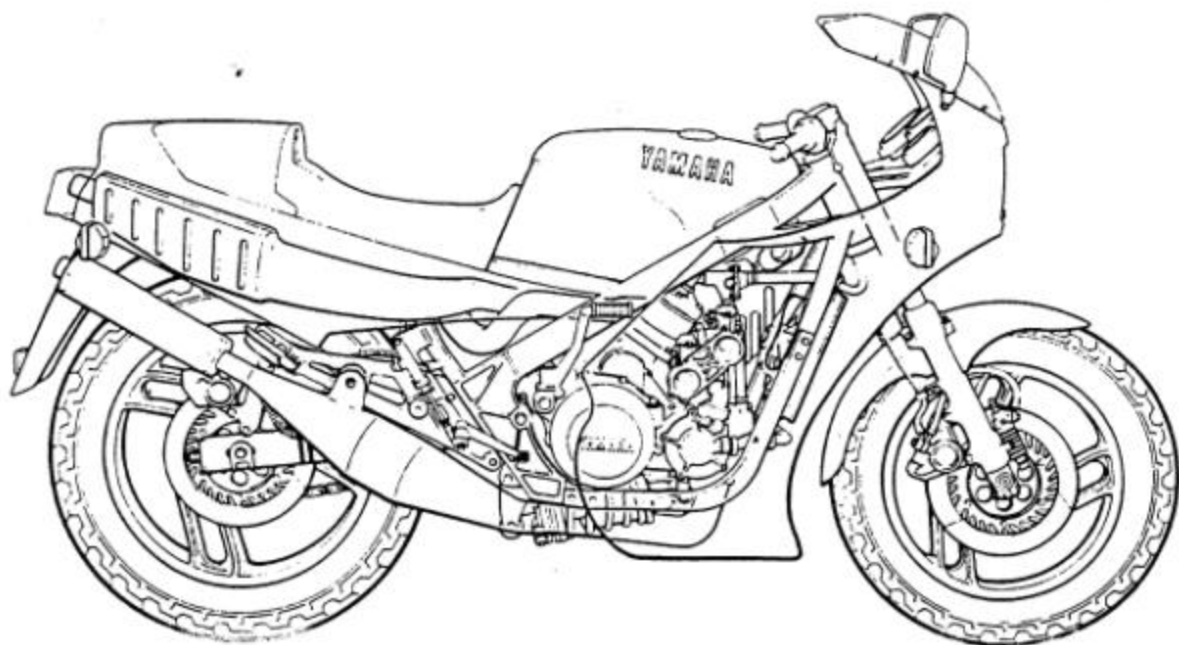

**IMPORTANT INFORMATION**

**ALL REPLACEMENT PARTS**

1. We recommend to use Yamaha genuine parts for all replacements. Use oil and/or grease recommended by Yamaha for assembly and adjustment.

**GASKETS, OIL SEALS, AND O-RINGS**

1. All gaskets, seals, and O-rings should be replaced when an engine is overhauled. All gasket surfaces, oil seal lips, and O-rings must be cleaned.
2. Properly oil all mating parts and bearings during reassembly. Apply grease to the oil seal lips.

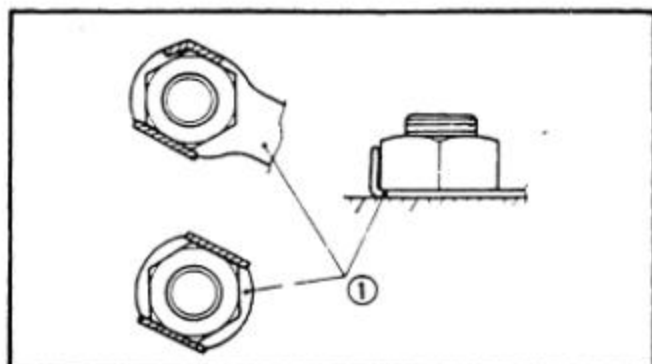

**LOCK WASHERS/PLATES AND COTTER PINS**

1. All lock washers/plates ① and cotter pins must be replaced when they are removed. Lock tab(s) should be bent along the bolt or nut flat(s) after the bolt or nut has been properly tightened.

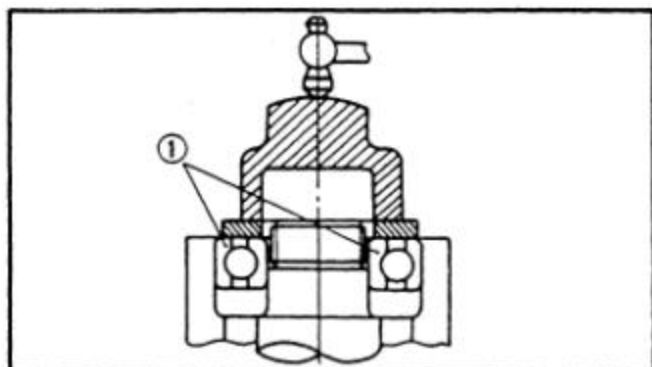

**BEARINGS AND OIL SEALS**

1. Install the bearing(s) ① and oil seal(s) ② with their manufacturer's marks or numbers facing outward. (In other words, the stamped letters must be on the side exposed to view.) When installing oil seal(s), apply a light coating of light-weight lithium base grease to the seal lip(s). Oil the bearings liberally when installing.

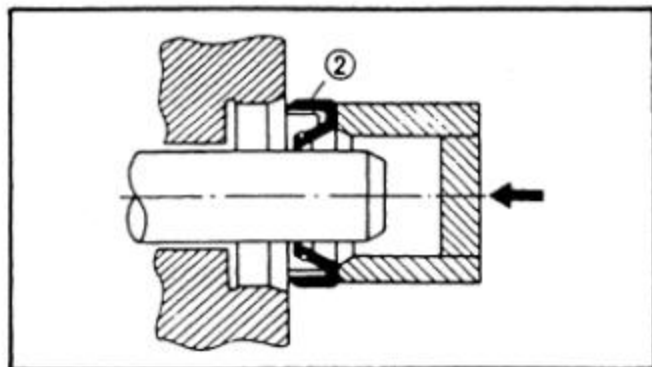

**CAUTION:**

Do not use compressed air to spin the bearings dry. This causes damage to the bearing surfaces.

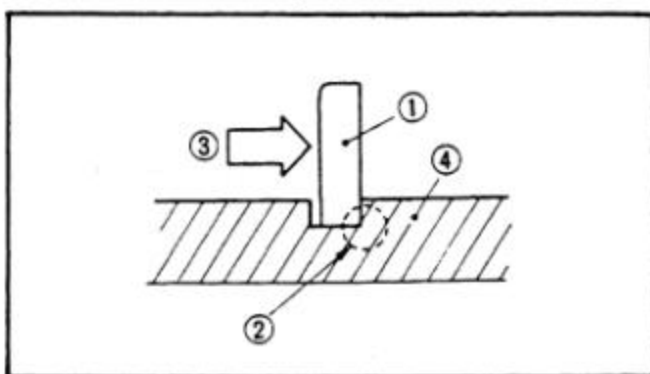

**CIRCLIPS**

1. All circlips should be inspected carefully before reassembly. Always replace piston pin clips after one use. Replace distorted circlips. When installing a circlip (1), make sure that the sharp-edged corner (2) is positioned opposite to the thrust (3) it receives. See the sectional view.

(4) Shaft

**SPECIAL TOOLS**

The proper special tools are necessary for complete and accurate tune-up and assembly. Using the correct special tool will help prevent damage caused by the use of improper tools or improvised techniques.

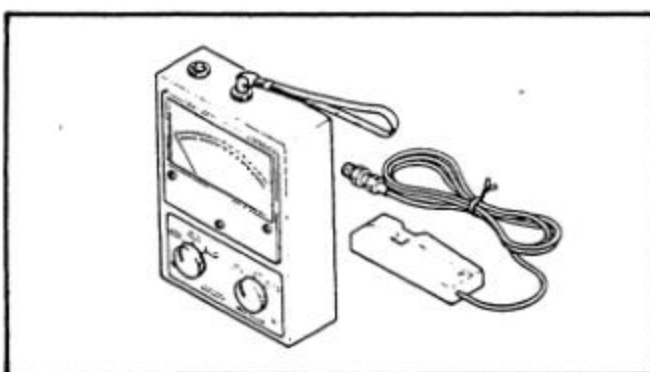

**FOR TUNE UP**

1. Inductive Tachometer  
P/N 90890-03082

This tool is needed for detecting engine rpm.

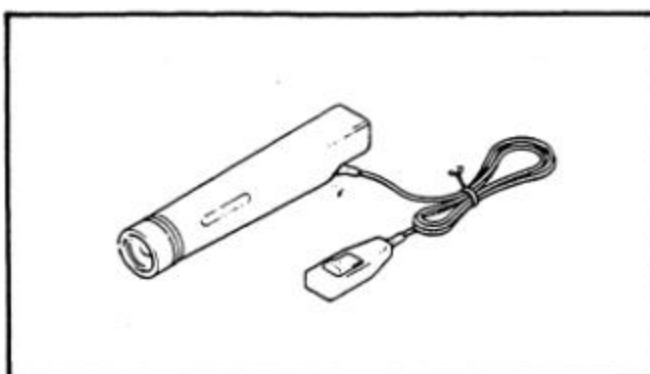

2. Inductive Timing Light  
P/N 90890-03109

This tool is necessary for checking ignition timing.

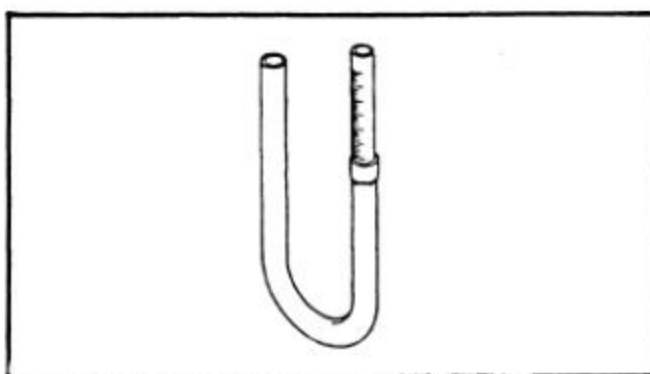

3. Fuel Level Gauge  
P/N 90890-01312

This gauge is used to measure the fuel level in the float chamber.

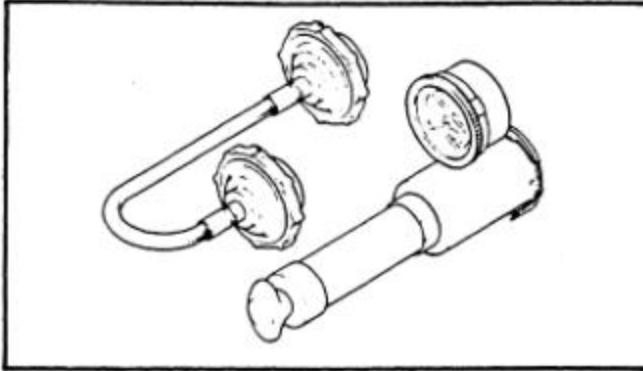

4. Cooling System Tester  
P/N 90890-01325

This tester is needed for checking the cooling system.

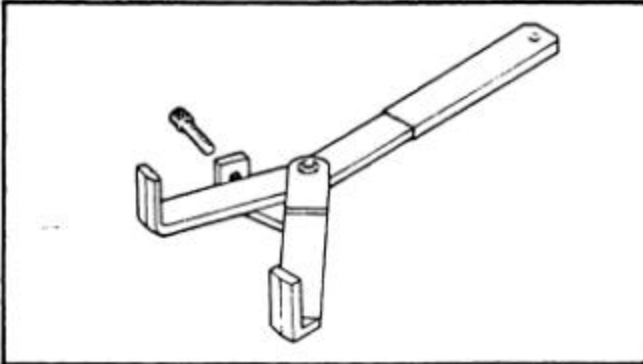

**FOR ENGINE SERVICE**

1. Universal Clutch Holder  
P/N 90890-04086

This tool is used to hold the clutch when removing or installing the clutch boss locknut.

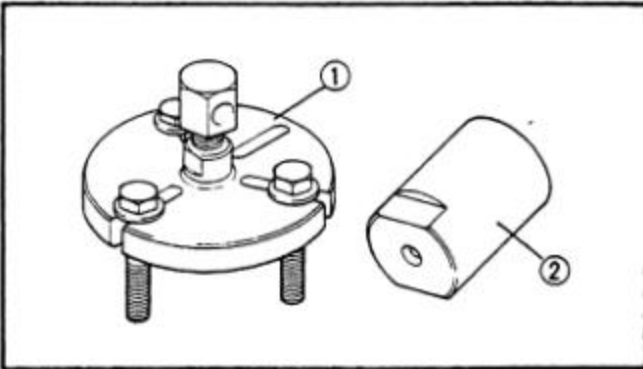

2. Flywheel Magneto Puller  
P/N 90890-01362 - ①  
Adapter  
P/N 90890-04063 - ②

These tools are used to remove the flywheel.

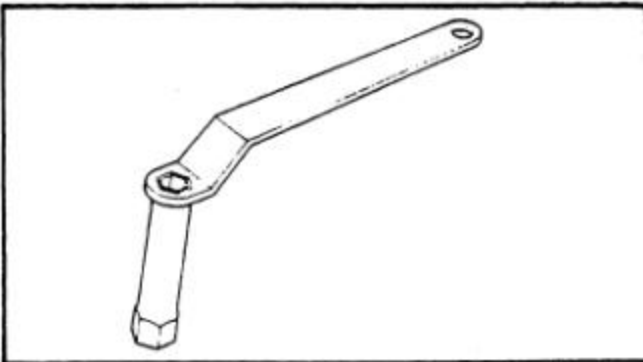

3. Clutch Adjusting Tool  
P/N 90890-01204

This tool is used to adjust the clutch.

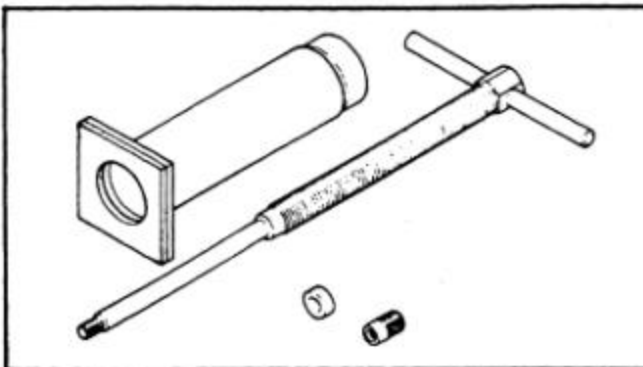

4. Piston Pin Puller  
P/N 90890-01304

This tool is used to remove the piston pin.

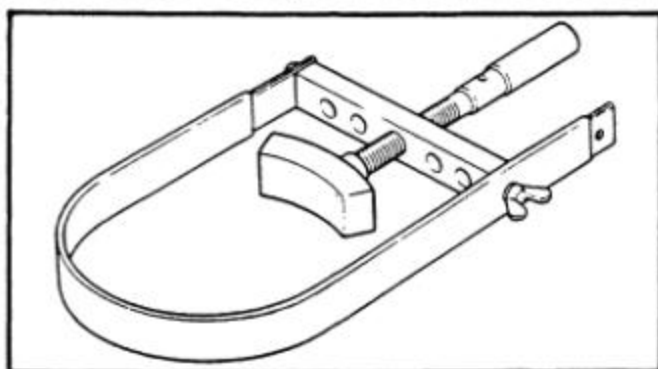

5. Universal Sheave Holder  
P/N 90890-01701

This tool is used to hold the flywheel when removing or installing the flywheel nut.

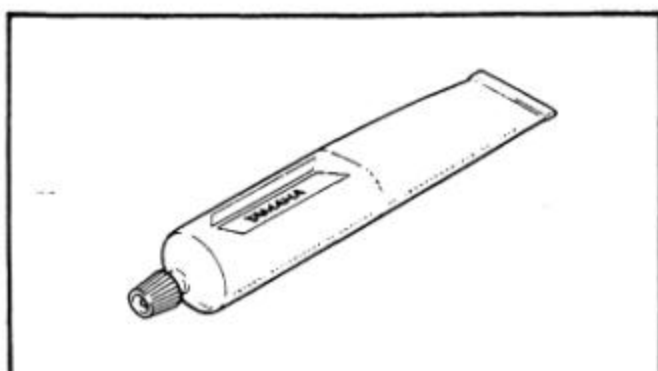

6. Yamaha Bond No. 1215  
P/N 90890-85505

This sealant (bond) is used for crankcase mating surfaces, etc.

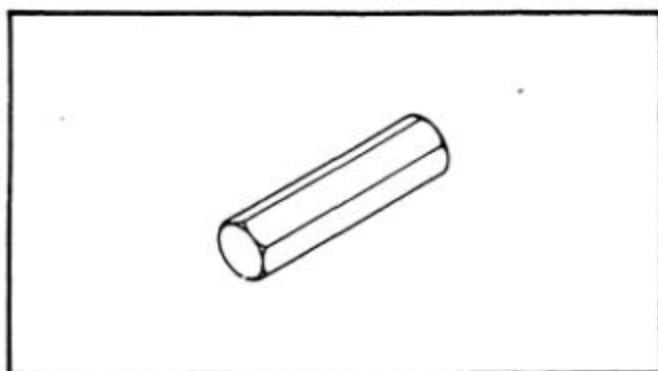

**FOR CHASSIS SERVICE**

1. Front Fork Cap Socket (17 mm)  
P/N 90890-01104

This tool is needed when loosening and tightening the front fork cap bolt.

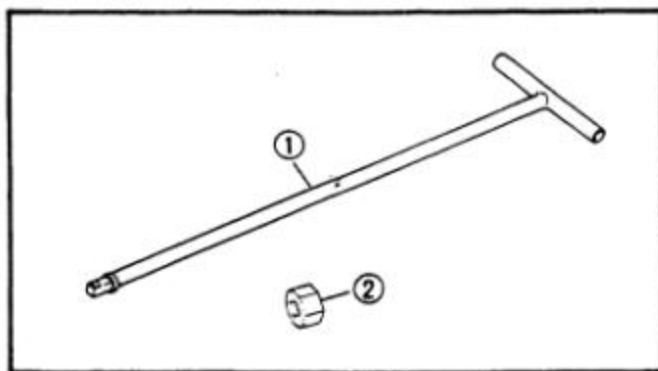

2. T-Handle  
P/N 90890-01326 - ①  
Damper Rod Holder (27 mm)  
P/N 90890-01388 - ②

This tool is used to loosen and tighten the front fork cylinder holding bolt.

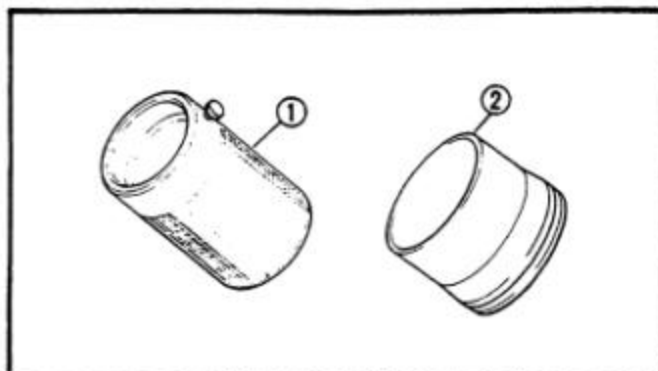

3. Front Fork Seal Driver (weight)  
P/N 90890-01367 - ①  
Adapter (41 mm)  
P/N 90890-01381 - ②

These tools are used when installing the fork seal.

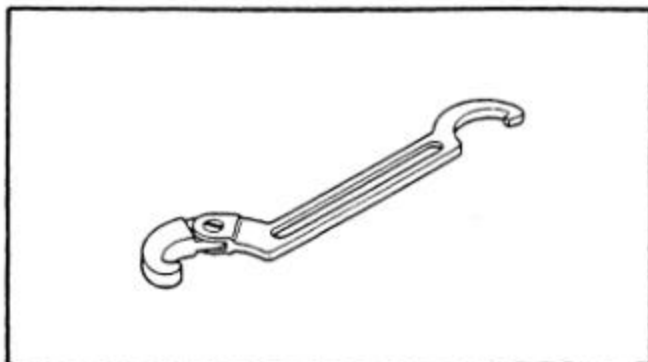

4. Ring Nut Wrench  
P/N 90890-01268

This tool is used to loosen and tighten the steering ring nut.



**FOR ELECTRICAL COMPONENTS**

1. Electro Tester  
P/N 90890-03021

This instrument is necessary for checking the ignition system components.

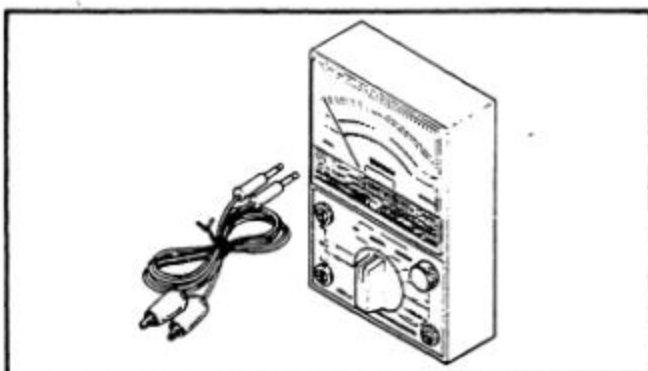

2. Pocket Tester  
P/N 90890-03104

This instrument is invaluable for checking the electrical system.

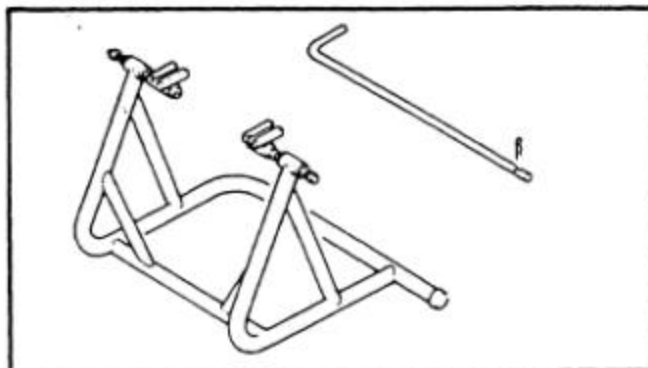

**OPTIONAL PARTS**

1. Racing Stand  
P/N 51X-W0780-00

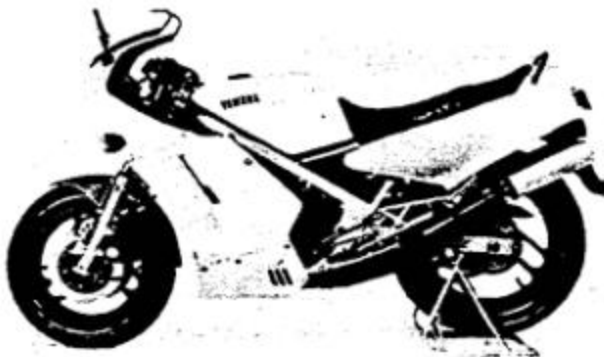
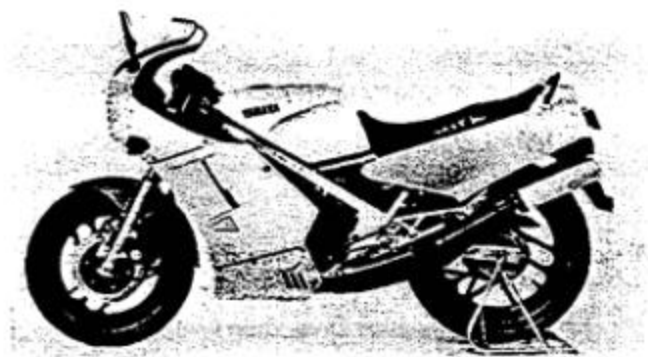

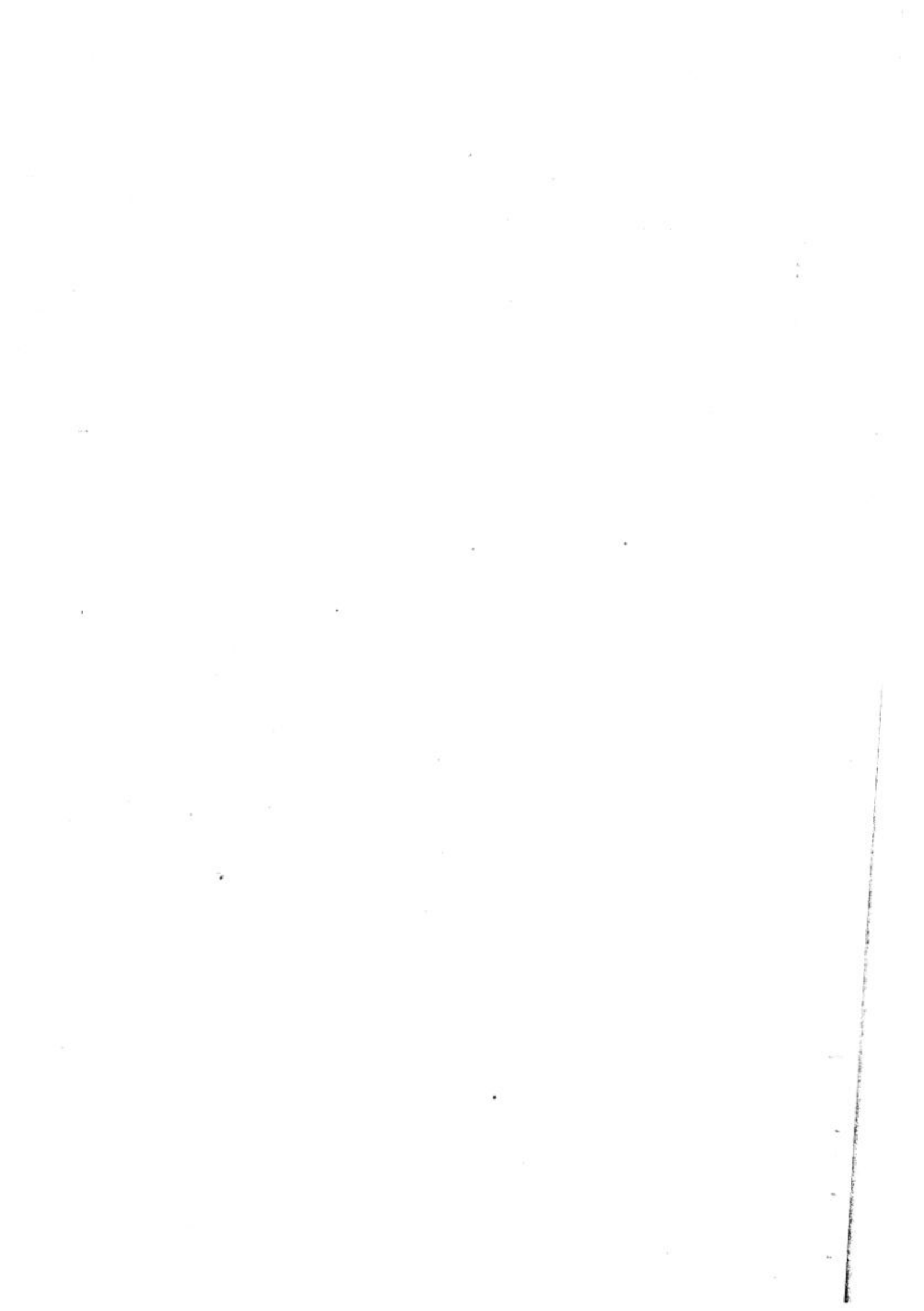

## CHAPTER 2. PERIODIC INSPECTIONS AND ADJUSTMENTS

INTRODUCTION .....	2-1
PERIODIC MAINTENANCE/LUBRICATION INTERVALS .....	2-1
<b>COWLING</b> .....	2-7
LOWER COWLING .....	2-7
CENTER COWLINGS .....	2-9
REAR COWLING .....	2-11
UPPER COWLING .....	2-15
<b>ENGINE</b> .....	2-19
SPARK PLUG .....	2-19
FUEL LINE .....	2-21
INTAKE MANIFOLD .....	2-21
EXHAUST SYSTEM .....	2-23
THROTTLE CABLE ADJUSTMENT .....	2-25
CARBURETOR SYNCHRONIZATION .....	2-27
IDLE SPEED .....	2-27
YPVS (YAMAHA POWER VALVE SYSTEM) .....	2-29
ENGINE OIL .....	2-31
OIL PUMP .....	2-33
TRANSMISSION OIL .....	2-35
COOLANT .....	2-37
CLUTCH ADJUSTMENT .....	2-39
IGNITION TIMING CHECK .....	2-41
<b>CHASSIS</b> .....	2-43
DRIVE CHAIN .....	2-43
AIR FILTER .....	2-45
BRAKE FLUID INSPECTION .....	2-47
FRONT AND REAR BRAKE PAD INSPECTION .....	2-49
FRONT BRAKE .....	2-49
REAR BRAKE .....	2-49
CABLE INSPECTION AND LUBRICATION .....	2-51
BRAKE AND CHANGE PEDALS/BRAKE AND CLUTCH LEVERS .....	2-51
SIDESTAND .....	2-53
SWINGARM AND RELAY ARM .....	2-53
FRONT FORK OIL CHANGE .....	2-55

REAR SHOCK ABSORBER ADJUSTMENT .....	2-61
ANTI-DIVE ADJUSTMENT .....	2-65
STEERING HEAD ADJUSTMENT .....	2-69
WHEEL BEARINGS .....	2-75
TUBELESS TIRES AND ALUMINUM WHEELS .....	2-79
<b>ELECTRICAL</b> .....	<b>2-83</b>
BATTERY .....	2-83
HEADLIGHT .....	2-85
TAILLIGHT .....	2-89
FUSE .....	2-89



## PERIODIC INSPECTIONS AND ADJUSTMENTS

### INTRODUCTION

This chapter includes all information necessary to perform recommended inspections and adjustments. These preventive maintenance procedures, if followed, will ensure more reliable vehicle operation and a longer service life. The need for costly overhaul work will be greatly reduced. This information applies to vehicles already in service as well as new vehicles that are being prepared for sale. All service technicians should be familiar with this entire chapter.

### PERIODIC MAINTENANCE/LUBRICATION INTERVALS

Unit: km (mi)

ITEM	REMARKS	BREAK-IN 1,000 (600)	EVERY	
			6,000 (4,000) or 6 months	12,000 (8,000) or 12 months
Spark plug(s)	Check condition. Clean or replace if necessary.	○	○	○
Air filter	Clean. Replace if necessary.		○	○
Carburetor*	Check idle speed/synchronization/starter operation. Adjust if necessary.	○	○	○
Fuel line*	Check fuel hose and vacuum pipe for cracks or damage. Replace if necessary.		○	○
Transmission oil*	Check oil level/oil leakage. Correct if necessary. Replace every 24,000 (16,000) or 24 months. Warm engine before draining.	REPLACE	○	○
Autolube pump*	Check operation. Correct if necessary. Air bleeding.	○	○	○
YPVS system*	Check operation. Correct if necessary.	○	○	○
Brake*	Check operation/fluid leakage/See NOTE. Correct if necessary.		○	○
Clutch	Check operation. Adjust if necessary.		○	○
Rear arm pivot*	Check rear arm assembly for looseness. Correct if necessary. Lubricate.***	○	○	○
Rear suspension link pivots*	Check operation. Lubricate.***	○	○	○
Wheels*	Check balance/damage/runout. Repair if necessary.		○	○
Wheel bearings*	Check bearing assembly for looseness/damage. Replace if damaged.		○	○
Steering bearing*	Check bearing assembly for looseness. Correct if necessary. Moderately repack every 24,000 (16,000) or 24 months.**	○		○

## PERIODIC MAINTENANCE/LUBRICATION INTERVALS



ITEM	REMARKS	BREAK-IN 1,000 (600)	EVERY	
			6,000 (4,000) or 6 months	12,000 (8,000) or 12 months
Front forks*	Check operation/oil leakage. Repair if necessary.		○	○
Rear shock absorber*	Check operation/oil leakage. Repair if necessary.		○	○
Cooling system	Check coolant leakage. Repair if necessary. Replace coolant every 24,000 (16,000) or 24 months.		○	○
Drive chain	Check chain slack/alignment. Adjust if necessary. Clean and lube.	EVERY 500 (300)		
Fittings/Fasteners*	Check all chassis fittings and fasteners. Correct if necessary.	○	○	○
Sidestand*	Check operation. Repair if necessary.	○	○	○
Battery*	Check specific gravity. Check breather pipe for proper operation. Correct if necessary.		○	○

\*: It is recommended that these items be serviced by a Yamaha dealer.

\*\* : Medium weight wheel bearing grease.

\*\*\* : Lithium soap base grease.

### NOTE:

#### Brake fluid replacement:

1. When disassembling the master cylinder or caliper cylinder, replace the brake fluid. Normally check the brake fluid level and add the fluid as required.
2. On the inner parts of the master cylinder and caliper cylinder, replace the oil seals every two years.
3. Replace the brake hoses every four years, or if cracked or damaged.

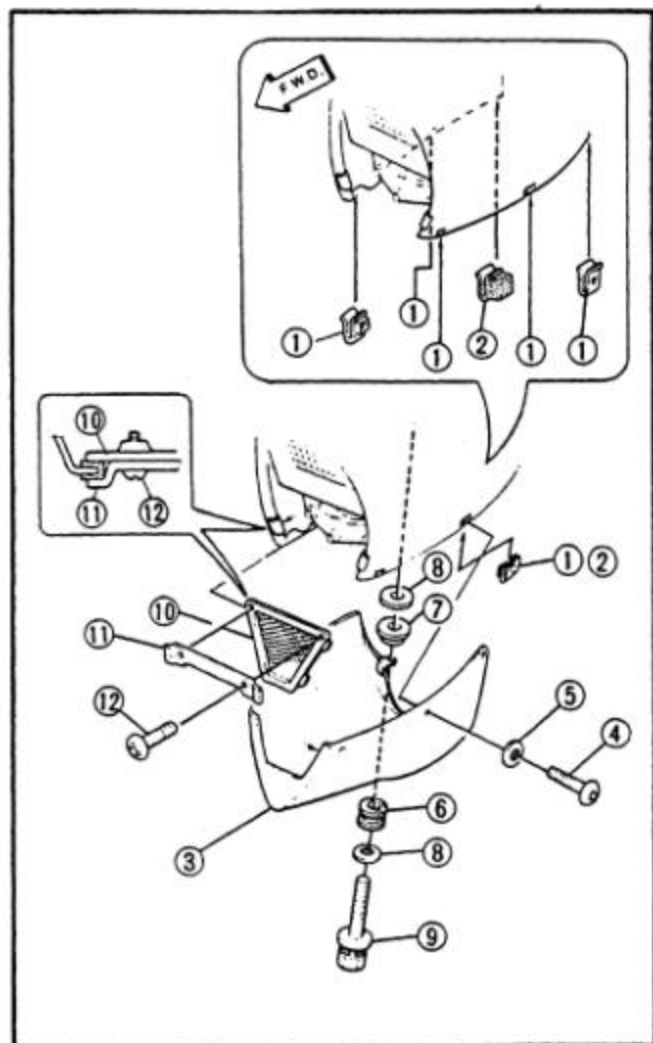
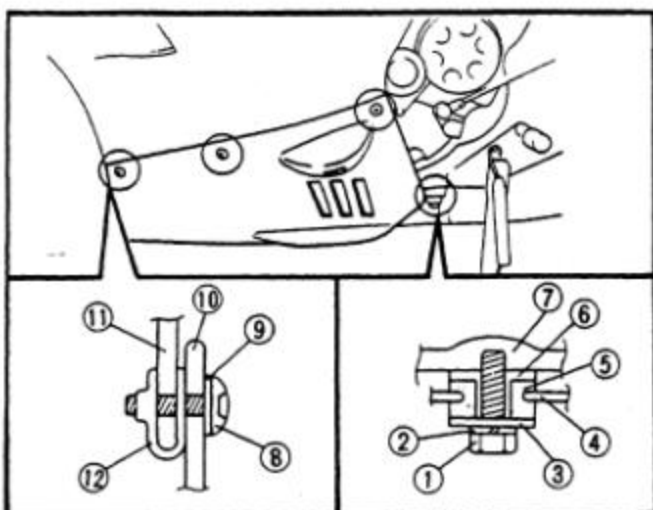
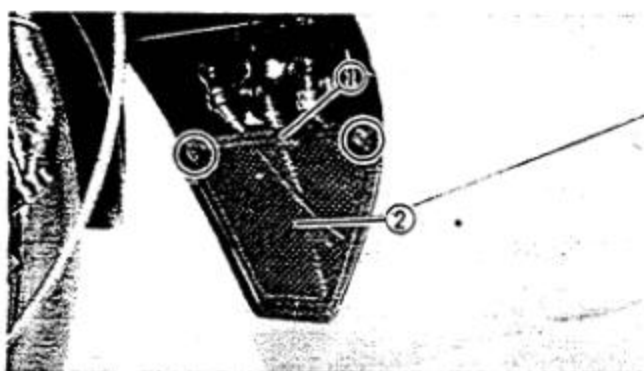

## COWLING

### LOWER COWLING

#### Removal

1. Remove:
  - Screws
  - Engine grille holder stay ①
  - Engine grille ②
  
2. Remove:
  - Mounting bolts
  - Lower cowling ④, ⑩

#### NOTE:

Do not lose the plastic washers ⑨.

- |                 |                            |
|-----------------|----------------------------|
| ① Hexagon bolt  | ⑦ Frame stay               |
| ② Spring washer | ⑧ Hexagon socket head bolt |
| ③ Plain washer  | ⑨ Plastic washer           |
| ④ Lower cowling | ⑩ Lower cowling            |
| ⑤ Grommet       | ⑪ Center cowling           |
| ⑥ Collar        | ⑫ Spring nut               |

#### Installation

1. Install:
  - Lower cowling
  - Mounting bolts
2. Tighten:
  - Bolts

Tighten the bolts evenly.
3. Install:
  - Engine grille

No.	Part name	Q'ty	Remarks mm (in)
①	Spring nut	5	d = 5 (0.20)
②	Spring nut (With damper)	1	d = 5 (0.20)
③	Lower cowling	1	
④	Hexagon socket head bolt	6	d = 5 (0.20), ℓ = 12 (0.47)
⑤	Plastic washer	6	d = 6 (0.24)
⑥	Grommet	2	Rubber
⑦	Collar	2	d = 6 (0.24)
⑧	Plain washer	4	d = 6 (0.24)
⑨	Hexagon bolt with spring washer and plain washer	2	d = 6 (0.24), ℓ = 20 (0.78)
⑩	Engine grille	1	
⑪	Holder stay	1	
⑫	Screw	2	d = 5 (0.20), ℓ = 12 (0.47)

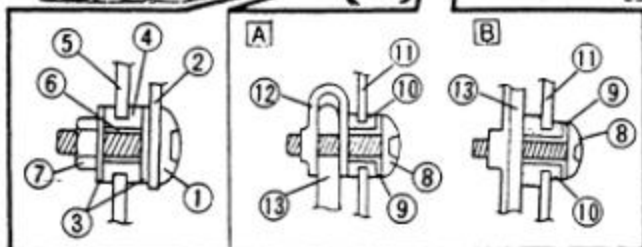
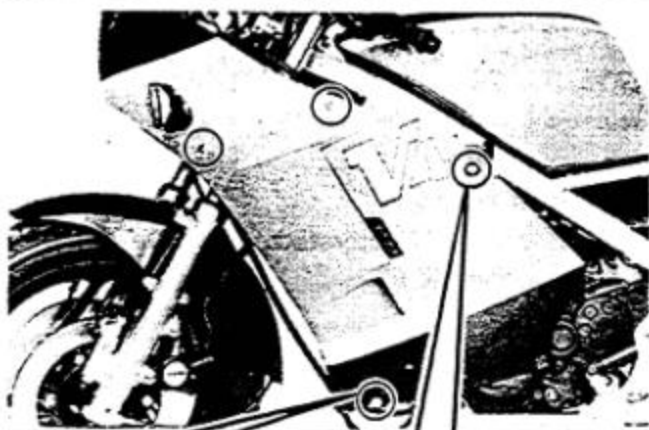

**CENTER COWLINGS**

**Removal**

1. Remove:
  - Engine grille
  - Lower cowling
  - Mounting bolts
  - Center cowlings

**NOTE:**

Do not lose the spring nuts ⑫ and washers.

- |                            |                            |
|----------------------------|----------------------------|
| ① Hexagon socket head bolt | ⑧ Hexagon socket head bolt |
| ② Center cowling           | ⑨ Collar                   |
| ③ Plain washer             | ⑩ Grommet                  |
| ④ Grommet                  | ⑪ Center cowling           |
| ⑤ Frame stay               | ⑫ Spring nut               |
| ⑥ Collar                   | ⑬ Air duct                 |
| ⑦ Hexagon nut              |                            |
| <b>A</b> RIGHT SIDE        | <b>B</b> LEFT SIDE         |

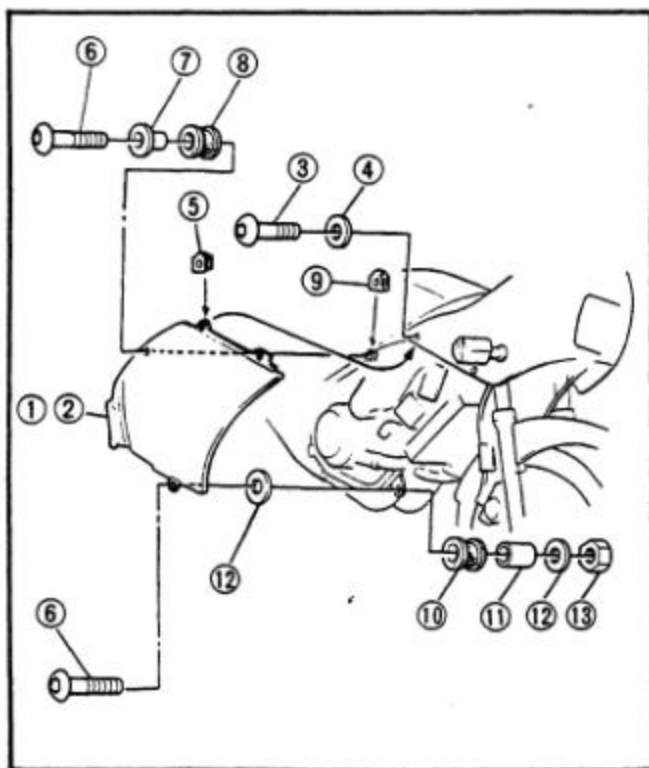

**Installation**

1. Install:
  - Center cowlings
  - Mounting bolts

Tighten bolts evenly.

  - Lower cowling
  - Engine grille

No.	Part name	Q'ty	Remarks mm (in)
①	Center cowling (Right)	1	
②	Center cowling (Left)	1	
③	Hexagon socket head bolt	4	d = 5 (0.20), ℓ = 12 (0.47)
④	Plain washer	4	d = 5 (0.20)
⑤	Spring nut	4	d = 5 (0.20)
⑥	Hexagon socket head bolt	4	d = 6 (0.24), ℓ = 22 (0.86)
⑦	Collar	2	d = 6 (0.24)
⑧	Grommet (Left and right)	2	Rubber
⑨	Spring nut (Right only)	1	d = 6 (0.24)
⑩	Grommet	2	Rubber
⑪	Collar	2	d = 6 (0.24)
⑫	Plain washer	4	d = 6 (0.24)
⑬	Hexagon nut	2	d = 6 (0.24)

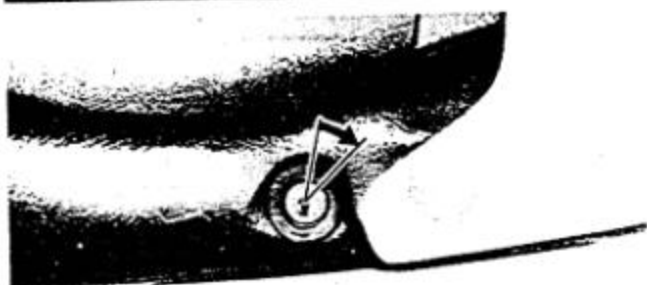

REAR COWLING

Removal

1. Remove:
  - Seat

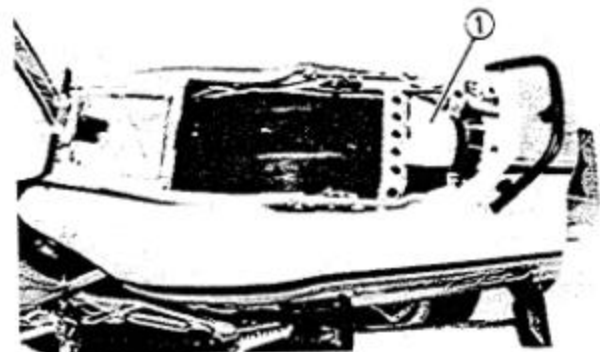

2. Remove:
  - Tool kit ①

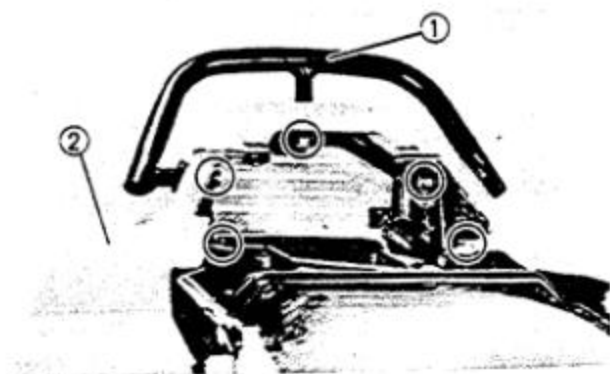

3. Remove:
  - Mounting bolts (Grab bar ①)
  - Mounting screws (Rear cowling ②)

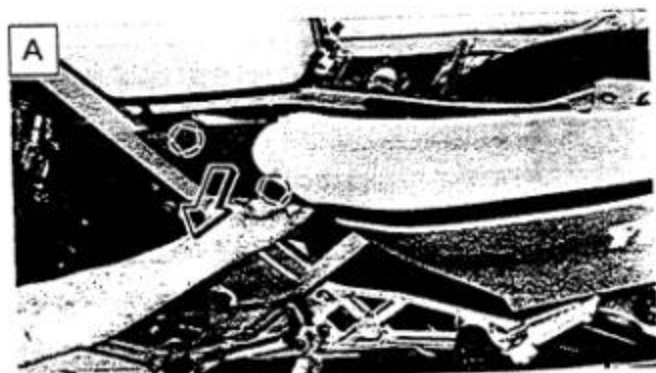

[A] LEFT

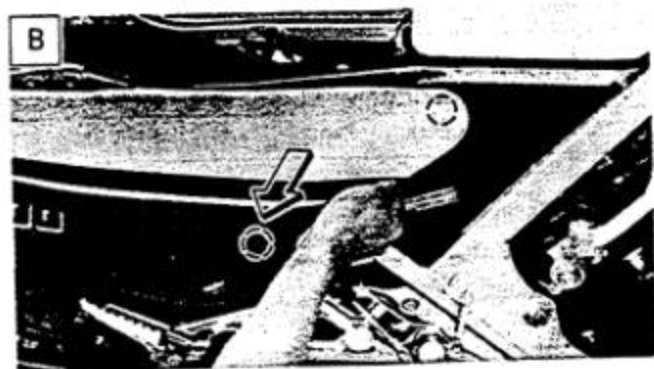

[B] RIGHT

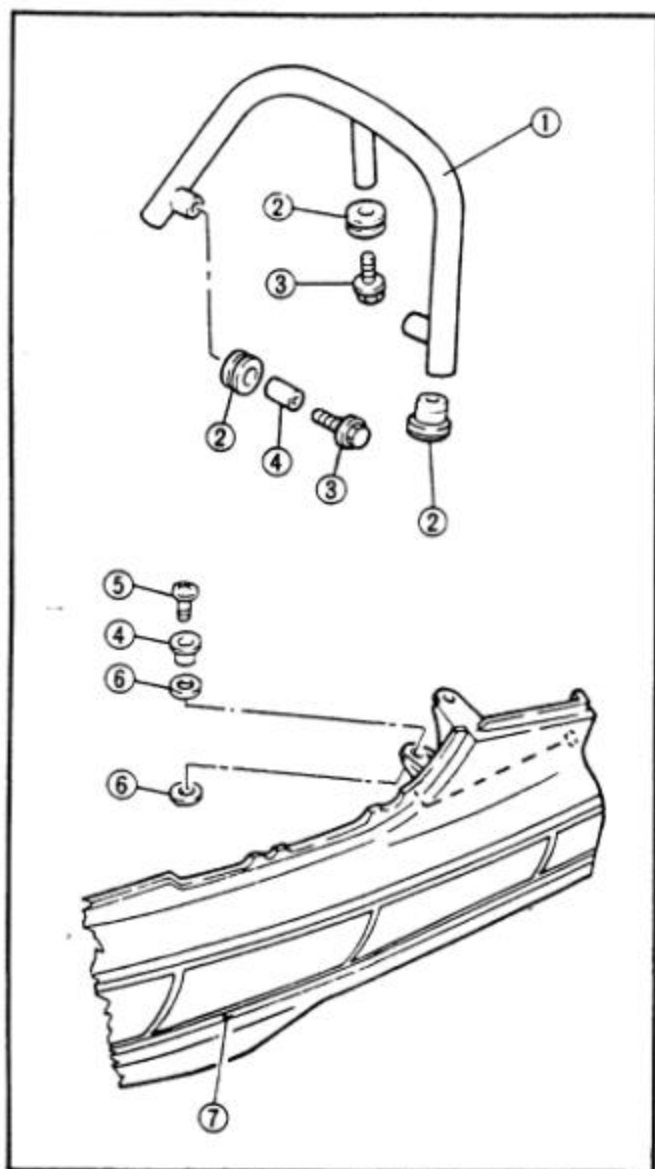

NOTE:

- Do not lose the collars ④ and gaskets ⑥.
- Inspect the cowling gaskets ⑥ and replace them if damaged.

- ① Grab bar
- ② Grommet
- ③ Bolt
- ④ Collar
- ⑤ Screw
- ⑥ Gasket
- ⑦ Rear cowling

5. Remove:

- Rear cowling assembly ①
  - Grab bar
- Remove together by pulling the grab bar rearwards.



Installation

1. Install:
  - Rear cowling

Reverse the removal procedure.
2. Tighten:
  - Mounting bolts (Grab bar)



Grab Bar:  
15 Nm (1.5 m·kg, 11 ft·lb)

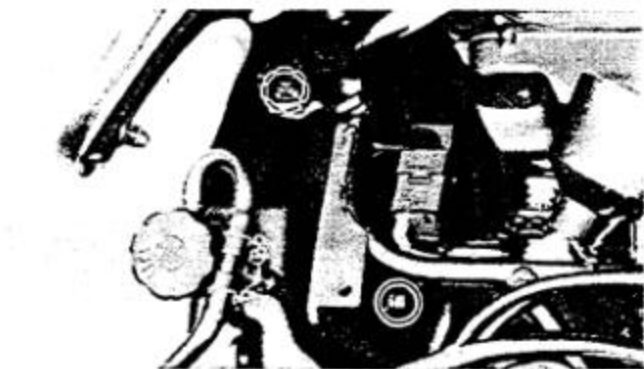
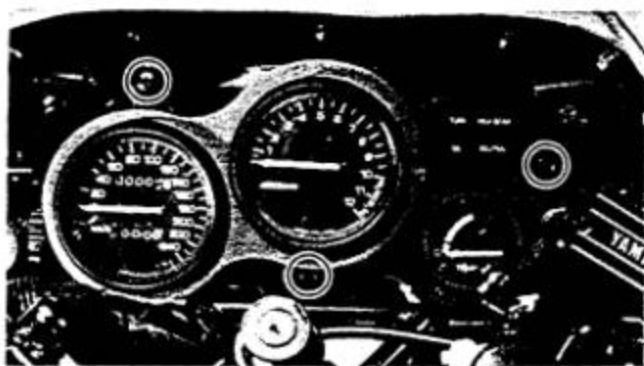

**UPPER COWLING**

**Removal**

1. Remove:
  - Lower cowling
  - Center cowlings
  - Meter assembly
2. Disconnect:
  - Flasher leads
  - Headlight connectors
  - Speedmeter cable
3. Remove:
  - Flasher lights
  - Cap retainer ①
  - Rear view mirror (Left) ②
  - Mounting bolt (Oil tank)
4. Pull up the oil tank.
  
5. Remove:
  - Mounting bolts
  
6. Remove:
  - Cap retainer ①
  - Rear view mirror (Right) ②
  - Meter cover ③
  - Mounting bolt (Reservoir tank)
7. Pull up the reservoir tank.
  
8. Remove:
  - Mounting bolts



9. Remove:
  - Mounting bolt

10. Remove:
  - Upper cowling

**Installation**

1. Install:
  - Upper cowling
  - Mounting bolts
2. Tighten:
  - Mounting bolts

Tighten the mounting bolts evenly.
3. Install:
  - Flasher lights
  - Rear view mirrors
  - Meter assembly
4. Connect:
  - Meter light
  - Headlight
  - Flasher lights
  - Speedometer cable
5. Install:
  - Meter cover
  - Center cowlings
  - Lower cowling

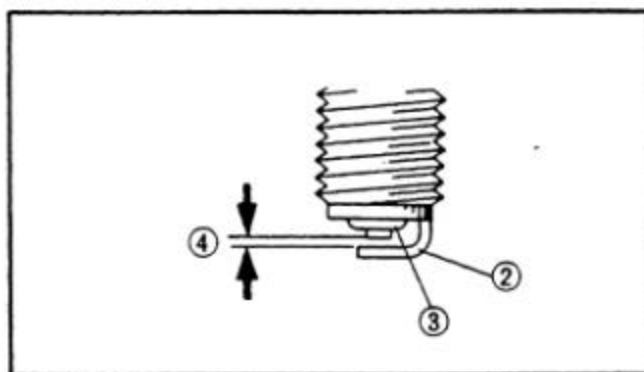
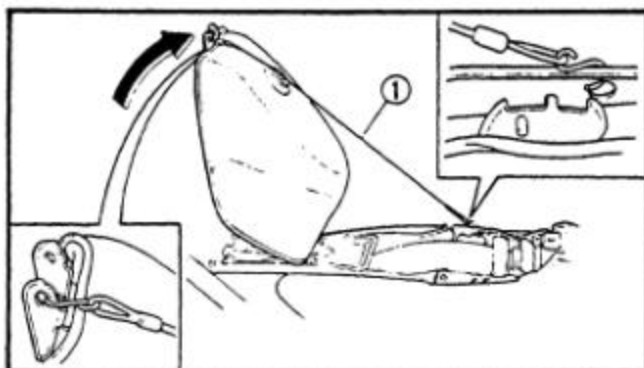

## ENGINE

## SPARK PLUG

- Remove:
  - Seat
  - Bolt (Fuel tank)

- Pull up the fuel tank. Use the fuel tank holding wire (1) as shown.

## NOTE:

The fuel tank holding wire (1) can be found in the owners tool kit.

- Remove:
  - Spark plugs
- Inspect:
  - Electrode (2)  
Wear/Damage → Replace.
  - Insulator (3)  
Abnormal color → Replace.
- Measure:
  - Plug gap (4)  
Use a Wire Gauge or Feeler Gauge.  
Out of specification → Regap.



**Spark Plug Gap:**  
0.6 ~ 0.7 mm (0.024 ~ 0.028 in)

- Clean the plug with a spark plug cleaner if necessary.

**Standard Spark Plug:**  
BR9HS (NGK)  
W27FSR (NIPPONDENSO)

- Tighten:
  - Spark plug(s)  
Before installing a spark plug, clean the gasket and plug surfaces.



**Spark Plug:**  
20 Nm (2.0 m·kg, 14 ft·lb)

## NOTE:

Finger-tighten the spark plug(s) before torquing to specification.



8. Install:
  - Fuel tank
  - Seat



**Fuel Tank:**  
10 Nm (1.0 m·kg, 7.2 ft·lb)

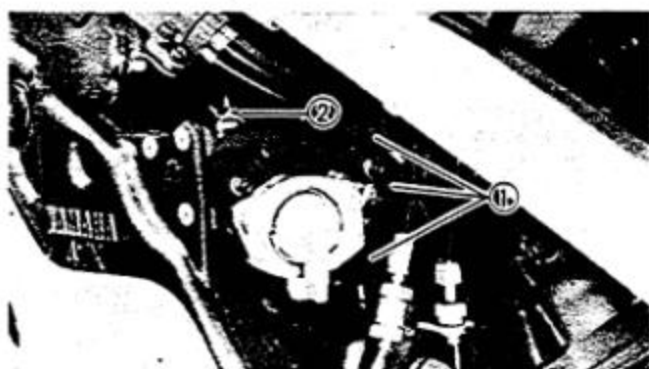

**FUEL LINE**

1. Inspect:
  - Fuel hoses ①
  - Vacuum hose ②
 Cracks/Damage → Replace.

**INTAKE MANIFOLD**

1. Tighten:
  - Carburetor clamps
  - Carburetor joint bolts
2. Inspect:
  - Carburetor joint ①
  - Gaskets ②
  - O-rings
 Cracks/Damage → Replace.

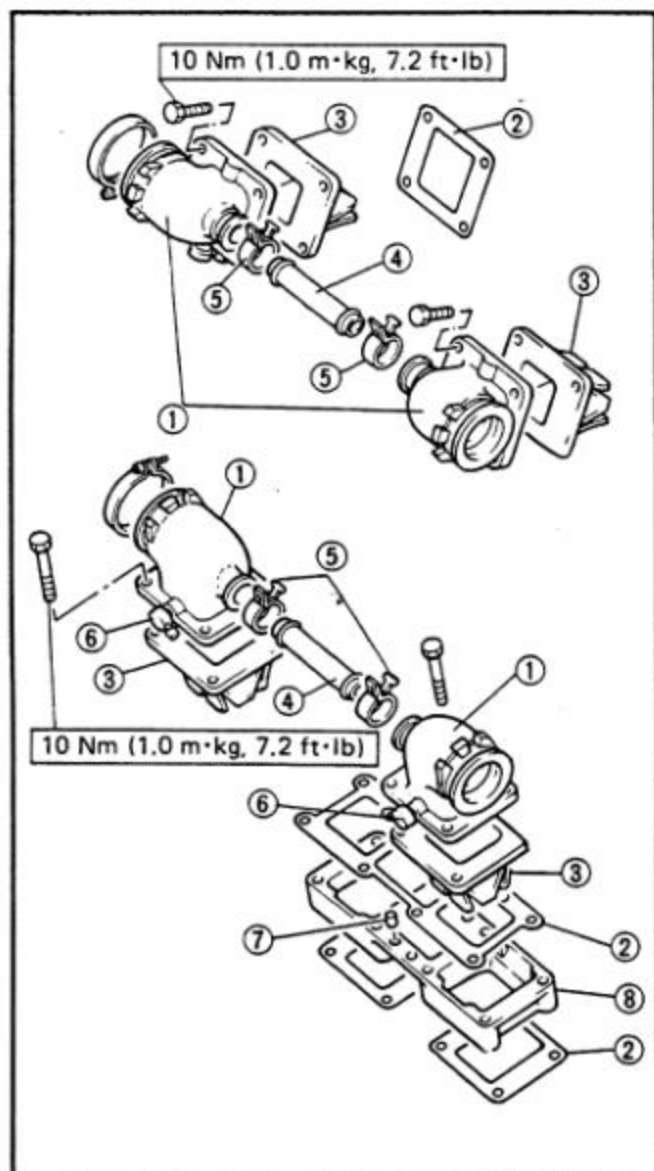

- ① Carburetor joint
- ② Gasket
- ③ Reed valve
- ④ Balancer pipe
- ⑤ Band
- ⑥ Delivery hose nozzle
- ⑦ Dowel pin
- ⑧ Housing

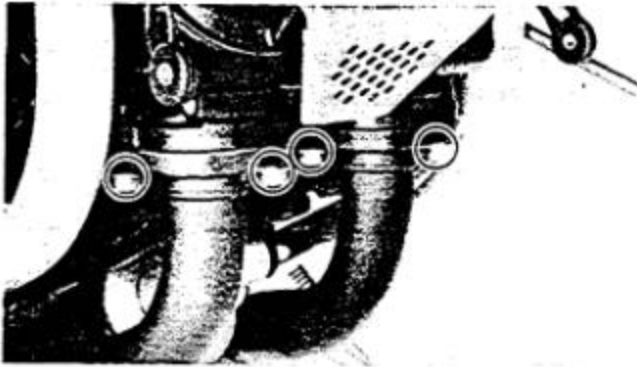

**EXHAUST SYSTEM**

1. Inspect:
  - Exhaust pipe gasket(s) ①
  - Silencer gasket(s) ②
  - Damage → Replace.
  - Exhaust gas leakage → Repair.
  - Silencer
  - Contamination → Clean.
  - Damage → Replace.
  
2. Tighten:
  - Exhaust pipe
  - Muffler
  - Silencer

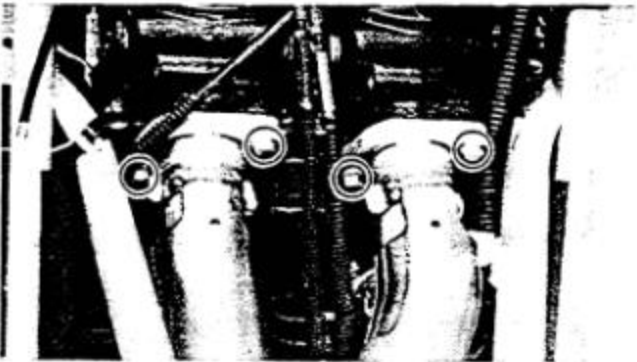

	<b>Exhaust Pipe (Studbolt):</b>
	13 Nm (1.3 m·kg, 9.4 ft·lb)
	<b>Muffler – Cylinder:</b>
	22 Nm (2.2 m·kg, 16 ft·lb)
	<b>Muffler – Muffler Bracket:</b>
	25 Nm (2.5 m·kg, 18 ft·lb)
	<b>Silencer (Nut/Screw):</b>
	6 Nm (0.6 m·kg, 4.3 ft·lb)

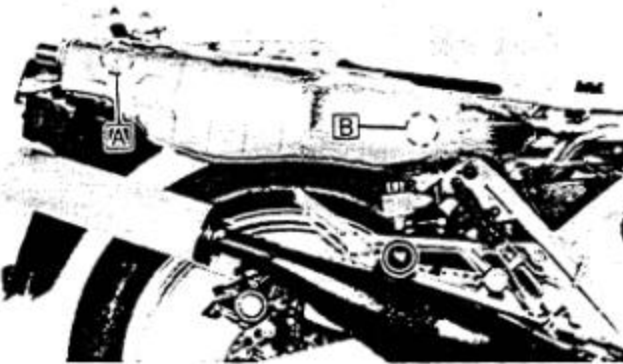

- A** Shorter bolt
- B** Longer bolt

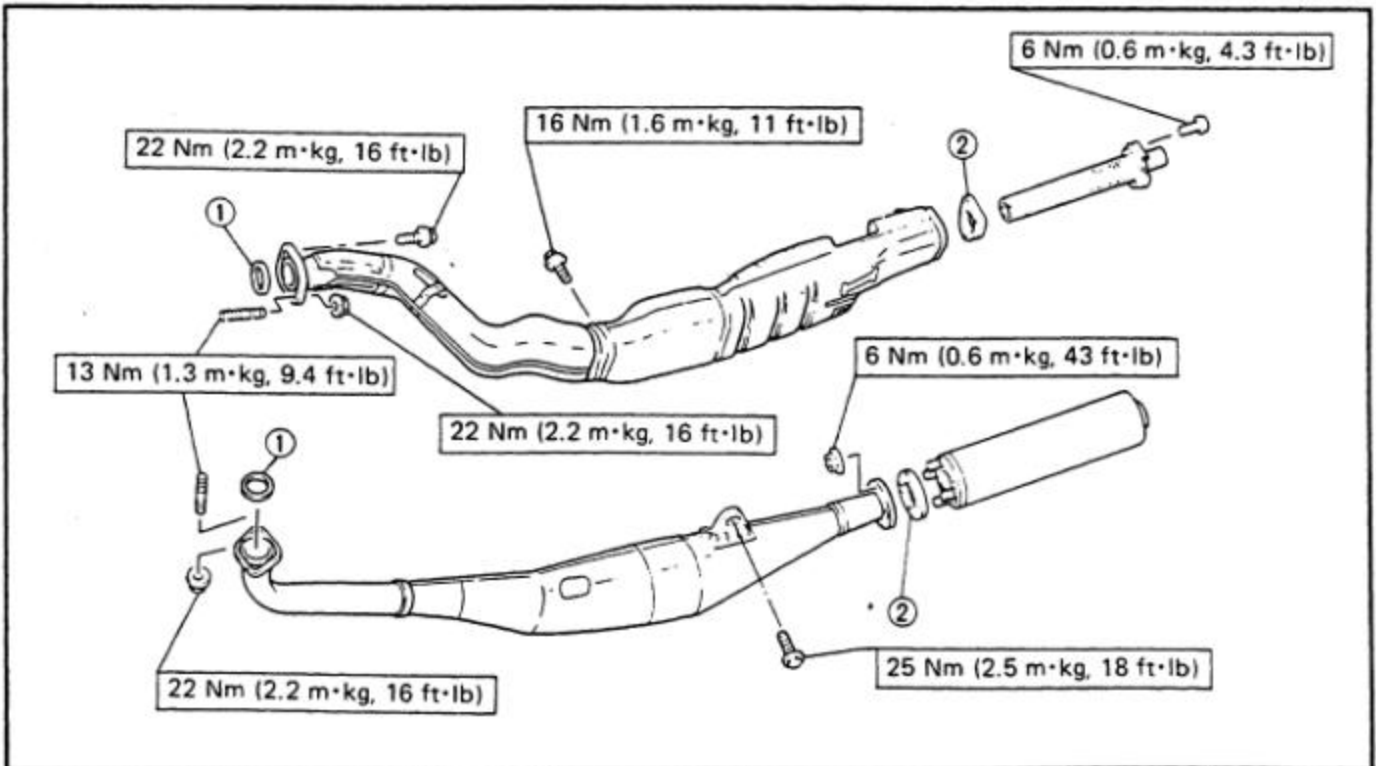



## THROTTLE CABLE ADJUSTMENT

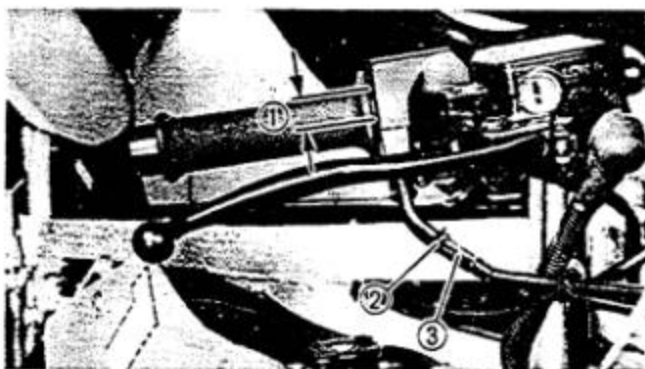
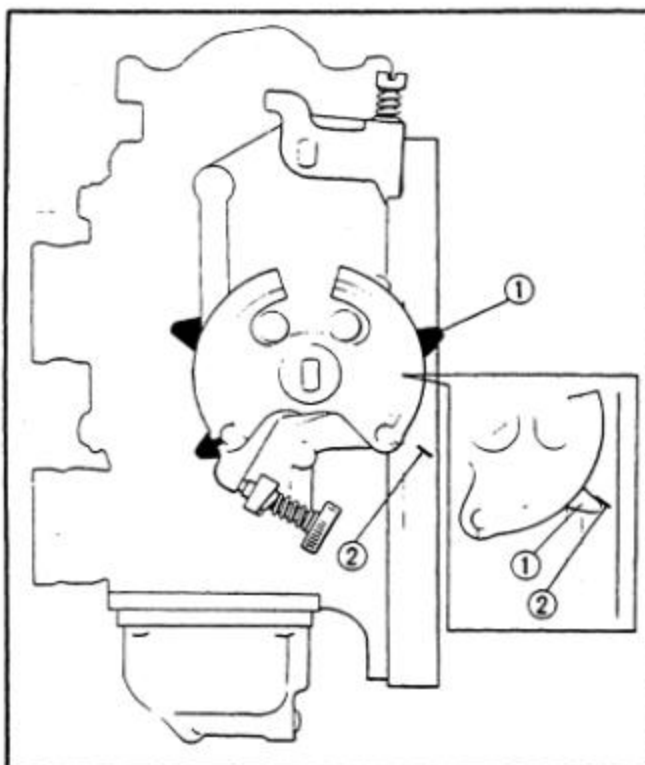

### THROTTLE CABLE ADJUSTMENT

Carburetors must be adjusted to open and close simultaneously.

1. Check:
  - Carburetor marks (at full throttle)  
Not aligned → Adjust the throttle cable.

#### Throttle cable adjustment steps (1):

- Turn the throttle grip until it stops completely so that all throttle valves are fully opened.
- While keeping the grip at this point (full throttle), check the carburetor pulley mark ① on each pair of carburetors. The pulley mark should align, as shown, with the full open mark ② on the carburetor body.
- If not, adjust the OPEN-SIDE throttle cable ③ by turning the adjuster ④ in or out.
- Next, check the CLOSE-SIDE throttle cables ⑤. They must have a slight free play. If not, adjust the close-side throttle cable by turning the adjuster ⑥ in or out.

7. Locknut

2. Check:
  - Throttle cable free play ①  
Out of specification → Adjust.

	<b>Throttle Cable Free Play ①:</b> 3 ~ 7 mm (0.12 ~ 0.28 in)
--	---

3. Adjust:
  - Throttle cable free play

#### Throttle cable adjustment step (2):

- Loosen the adjuster locknut ②.
- Adjust the free play by turning the adjuster ③ in or out.
- Tighten the locknut.