

Product: 2000 Yamaha FZR600(W-D) Motorcycle Service Repair Workshop Manual  
Full Download: <https://www.arepairmanual.com/downloads/2000-yamaha-fzr600w-d-motorcycle-service-repair-workshop-manual/>



**YAMAHA**

**FZR600RB  
FZR600RBC**

**SUPPLEMENTARY  
SERVICE MANUAL**

Sample manual. Download All pages at:

<https://www.arepairmanual.com/downloads/2000-yamaha-fzr600w-d-motorcycle-service-repair-workshop-manual/>

**LIT-11616-07-60**

**3HH-28197-13**

## NOTICE

This manual was written by the Yamaha Motor Company primarily for use by Yamaha dealers and their qualified mechanics. It is not possible to put an entire mechanic's education into one manual, so it is assumed that persons using this book to perform maintenance and repairs on Yamaha motorcycles have a basic understanding of the mechanical concepts and procedures inherent in motorcycle repair technology. Without such knowledge, attempted repairs or service to this model may render it unfit to use and/or unsafe.

This model has been designed and manufactured to perform within certain specifications in regard to performance and emissions. Proper service with the correct tools is necessary to ensure that the motorcycle will operate as designed. If there is any question about a service procedure, it is imperative that you contact a Yamaha dealer for any service information changes that apply to this model. This policy is intended to provide the customer with the most satisfaction from his motorcycle and to conform with federal environmental quality objectives.

Yamaha Motor Company, Ltd. is continually striving to improve all models manufactured by Yamaha. Modifications and significant changes in specifications or procedures will be forwarded to all Authorized Yamaha dealers and will, where applicable, appear in future editions of this manual.

### NOTE:

---

This Service Manual contains information regarding periodic maintenance to the emission control system for the FZR600RB/RBC. Please read this material carefully.

---

TECHNICAL PUBLICATIONS  
SERVICE DIVISION  
MOTORCYCLE GROUP  
YAMAHA MOTOR CO., LTD.

## PARTICULARLY IMPORTANT INFORMATION

This material is distinguished by the following notation.



The Safety Alert Symbol means ATTENTION! BECOME ALERT! YOUR SAFETY IS INVOLVED!

### **WARNING**

Failure to follow WARNING instructions could result in severe injury or death to the motorcycle operator, a bystander, or a person inspecting or repairing the motorcycle.

### **CAUTION:**

A CAUTION indicates special precautions that must be taken to avoid damage to the motorcycle.

### NOTE:

A NOTE provides key information to make procedures easier or clearer.

# HOW TO USE THIS MANUAL

## CONSTRUCTION OF THIS MANUAL

This manual consists of chapters for the main categories of subjects. (See "Illustrated symbols")

- 1st title ① : This is a chapter with its symbol on the upper right of each page.
- 2nd title ② : This title appears on the upper of each page on the left of the chapter symbol. (For the chapter "Periodic inspection and adjustment" the 3rd title appears.)
- 3rd title ③ : This is a final title.

## MANUAL FORMAT

All of the procedures in this manual are organized in a sequential, step-by-step format. The information has been compiled to provide the mechanic with an easy to read, handy reference that contains comprehensive explanations of all disassembly, repair, assembly, and inspections. A set of particularly important procedure ④ is placed between a line of asterisks "\*" with each procedure preceded by "●".









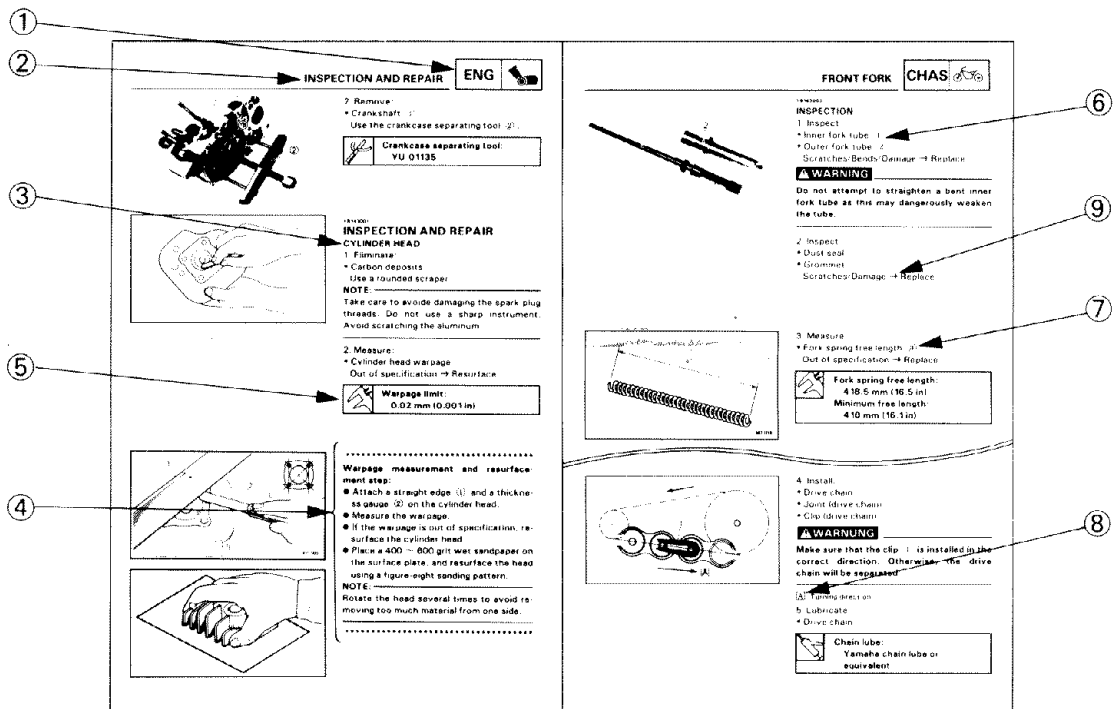













## IMPORTANT FEATURES

- Data and a special tool are framed in a box preceded by a relevant symbol ⑤.
- An encircled numeral ⑥ indicates a part name, and an encircled alphabetical letter data or an alignment mark ⑦, the others being indicated by an alphabetical letter in a box ⑧.
- A condition of a faulty component will precede an arrow symbol and the course of action required the symbol ⑨.

## EXPLODED DIAGRAM

Each chapter provides exploded diagrams before each disassembly section for ease in identifying correct disassembly and assembly procedures.



① GEN INFO 	② SPEC 	
③ INSP ADJ 	④ ENG 	
⑤ COOL 	⑥ CARB 	
⑦ CHAS 	⑧ ELEC 	
⑨ TRBL SHTG ?	⑩ 	
⑪ 	⑫ 	
⑬ 	⑭ 	
⑮ 	⑯ 	
⑰ 	⑱ 	⑲ 
⑳ 	㉑ 	㉒ 
㉓ 		

## ILLUSTRATED SYMBOLS (Refer to the illustration)

Illustrated symbols ① to ⑨ are designed as thumb tabs to indicate the chapter's number and content.

- ① General information
- ② Specifications
- ③ Periodic inspection and adjustment
- ④ Engine
- ⑤ Cooling system
- ⑥ Carburetion
- ⑦ Chassis
- ⑧ Electrical
- ⑨ Troubleshooting

Illustrated symbols ⑩ to ⑯ are used to identify the specifications appearing.

- ⑩ Filling fluid
- ⑪ Lubricant
- ⑫ Special tool
- ⑬ Tightening
- ⑭ Wear limit, clearance
- ⑮ Engine speed
- ⑯  $\Omega$ , V, A

Illustrated symbols ⑰ to ㉓ in the exploded diagram indicate grade of lubricant and location of lubrication point.

- ⑰ Apply engine oil
- ⑱ Apply gear oil
- ⑲ Apply molybdenum disulfide oil
- ⑳ Apply wheel bearing grease
- ㉑ Apply lightweight lithium-soap base grease
- ㉒ Apply molybdenum disulfide grease
- ㉓ Apply locking agent (LOCTITE®)

---

## CONTENTS

<b>GENERAL INFORMATION</b> .....	1
MOTORCYCLE IDENTIFICATION NUMBER .....	1
VEHICLE IDENTIFICATION NUMBER .....	1
ENGINE SERIAL NUMBER .....	1
SPECIAL TOOLS .....	2
FOR ENGINE SERVICE .....	2
<b>SPECIFICATIONS</b> .....	3
GENERAL SPECIFICATIONS .....	3
MAINTENANCE SPECIFICATIONS .....	4
ENGINE .....	4
CHASSIS .....	9
ELECTRICAL .....	11
LUBRICATION DIAGRAM .....	12
COOLANT DIAGRAM .....	15
CABLE ROUTING .....	17
<b>PERIODIC INSPECTION AND ADJUSTMENT</b> .....	25
COWLINGS/COVERS REMOVAL AND INSTALLATION .....	25
REMOVAL .....	25
ENGINE .....	27
ENGINE OIL REPLACEMENT .....	27
ENGINE OIL FILTER REPLACEMENT .....	28
COOLANT REPLACEMENT .....	30
ELECTRICAL .....	33
HEADLIGHT BEAM ADJUSTMENT .....	33
HEADLIGHT BULB REPLACEMENT .....	33
<b>ENGINE OVERHAUL</b> .....	35
ENGINE DISASSEMBLY .....	35
OIL PAN AND OIL STRAINER .....	35
ENGINE ASSEMBLY AND ADJUSTMENT .....	36
OIL PAN AND OIL STRAINER .....	36
<b>COOLING SYSTEM</b> .....	38
RADIATOR .....	38
THERMOSTATIC VALVE AND WATER PUMP .....	39
<b>ELECTRICAL</b> .....	40
CIRCUIT DIAGRAM .....	40
ELECTRICAL STARTING SYSTEM .....	42
CIRCUIT DIAGRAM .....	42
TROUBLESHOOTING .....	44
FUEL PUMP SYSTEM .....	50
CIRCUIT DIAGRAM .....	50
FUEL PUMP CIRCUIT OPERATION .....	52
TROUBLESHOOTING .....	53
EXUP SYSTEM (FOR CALIFORNIA ONLY) .....	58
CIRCUIT DIAGRAM .....	58
TROUBLESHOOTING .....	60
FZR600RB/FZR600RBC WIRING DIAGRAM	



## GENERAL INFORMATION

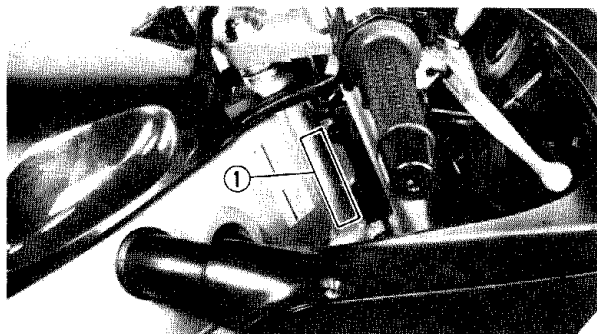

### MOTORCYCLE IDENTIFICATION VEHICLE IDENTIFICATION NUMBER

The vehicle identification number ① is stamped into the right side of the steering head.

**Starting serial number:**  
**FZR600RB (Except for California):**  
 JYA3HHE0 \* MA032101  
**FZR600RBC (For California):**  
 JYA3UUC0 \* MA003101

#### NOTE:

The vehicle identification number is used to identify your motorcycle and may be used to register your motorcycle with the licensing authority in your state.

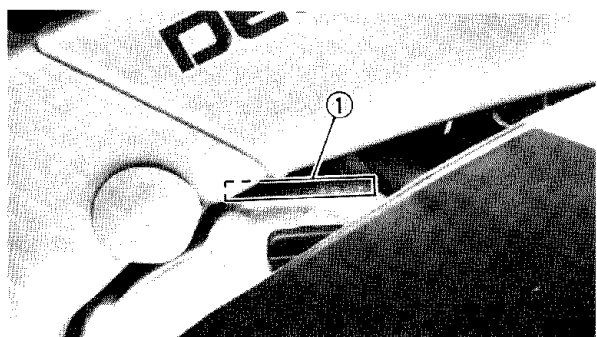

### ENGINE SERIAL NUMBER

The engine serial number ① is stamped into the right side of the engine.

**Starting serial number:**  
**FZR600RB (Except for California):**  
 3HH-032101  
**FZR600RBC (For California):**  
 3UU-003101

#### NOTE:

- The first three digits of these numbers are for model identifications; the remaining digits are the unit production number.
- Designs and specifications are subject to change without notice.



## SPECIAL TOOLS

The proper special tools are necessary for complete and accurate tune-up and assembly. Using the correct special tool will help prevent damage caused by the use of improper tools or improvised techniques. The shape and part number used for the special tool differ by country, so two types are provided. Refer to the list provided to avoid errors when placing an order.

P/N. YM-□□□□□ , YU-□□□□□	} For US, CDN
YS- □□□□□ , YK- □□□□□	
ACC-□□□□□	
P/N. 90890-□□□□□	} Except for US, CDN

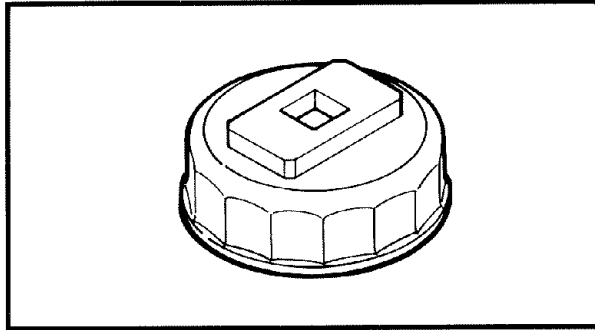

### FOR ENGINE SERVICE

#### 7. Oil filter wrench

P/N J-37140A

P/N 90890-01426

This tool is used to loosen or tighten the oil filter.



**SPECIFICATIONS**

**GENERAL SPECIFICATIONS**

Model	FZR600RB/RBC	
	FZR600RB	FZR600RBC
Model Code Number	3HH6	3UU2
Vehicle Identification Number	JYA3HHE0 * MA032101	JYA3UUC0 * MA003101
Engine Starting Number	3HH-032101	3UU-003101
Dimensions:		
Overall Length	2,095 mm (82.5 in)	
Overall Width	700 mm (27.6 in)	
Overall Height	1,155 mm (45.5 in)	
Seat Height	785 mm (30.9 in)	
Wheelbase	1,425 mm (56.1 in)	
Minimum Ground Clearance	135 mm ( 5.3 in)	
Basic Weight:		
With Oil and Full Fuel Tank	201 kg (443 lb), 206 kg (454 lb) (FZR600RBC)	
Transmission:		
Primary Reduction System	Spur gear	
Primary Reduction Ratio	82/48 (1.708)	
Secondary Reduction System	Chain drive	
Secondary Reduction Ratio	45/15 (3.000)	
Transmission Type	Constant-mesh, 6-speed	
Operation	Left foot operation	
Gear Ratio	1st	37/13 (2.846)
	2nd	37/19 (1.947)
	3rd	31/20 (1.550)
	4th	28/21 (1.333)
	5th	31/26 (1.192)
	6th	30/27 (1.111)
Tire:	Front	Rear
Type	Tubeless	Tubeless
Size	110/70 VR17-V240 110/70 ZR17 (FZR600RBC)	140/60 VR18-V240 140/60 ZR18 (FZR600RBC)
Manufacture (Type)	Michelin (A59) Pirelli (MP7) Dunlop (SPORT MAX) Bridgestone (CYROX-17)	Michelin (M59) Pirelli (MP7) Dunlop (SPORT MAX) Bridgestone (CYROX-16)
Maximum Load*	157 kg (346 lb) 152 kg (335 lb) (FZR600RBC)	
Tire Pressure (Cold tire):	Front	Rear
Up to 90 kg (198 lb) load *	225 kPa (2.25 kg/cm <sup>2</sup> , 33 psi)	250 kPa (2.5 kg/cm <sup>2</sup> , 36 psi)
90 kg (198 lb) ~ Maximum load *	250 kPa (2.5 kg/cm <sup>2</sup> , 36 psi)	290 kPa (2.9 kg/cm <sup>2</sup> , 42 psi)
High speed riding	250 kPa (2.5 kg/cm <sup>2</sup> , 36 psi)	290 kPa (2.9 kg/cm <sup>2</sup> , 42 psi)

\*Load is total weight of cargo, rider, passenger, and accessories.



# MAINTENANCE SPECIFICATIONS



Model	FZR600RB/RBC
Shock Absorber: Front Shock Absorber Rear Shock Absorber	Coil-air spring, oil damper Coil-gas spring, oil damper
Electrical: Ignition System Generator System Battery Type or Model Battery Capacity	T.C.I. (Digital ignition) A.C. magneto generator GM12AZ 12V12AH
Headlight Type:	Quartz bulb (Halogen)
Bulb Wattage x Quantity: Headlight Tail/Brake Light Flasher Light Front Position Light Meter Light	12V 60W/55W 12V 8W/27W x 2 12V 27W x 4 12V 8W x 2 12V 1.7W x 8.4

## MAINTENANCE SPECIFICATIONS

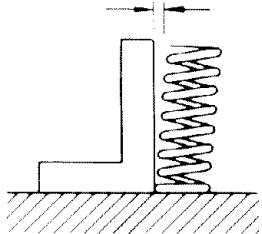
### ENGINE

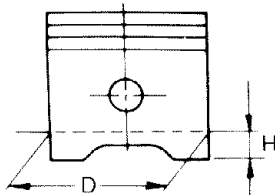
Model	FZR600RB/RBC
Valve Spring: Free Length < Limit > Installed Length (Valve Closed) Compressed Pressure (Valve closed) < Limit > Tilt Limit 	43.15 mm (1.70 in) 43.15 mm (1.70 in) 41.2 mm (1.62 in) 41.2 mm (1.62 in) 37.5 mm (1.48 in) 37.5 mm (1.48 in) 11.6 ~ 13.4 kg (25.9 ~ 29.6 lb) 11.6 ~ 13.4 kg (25.9 ~ 29.6 lb) 10.4 kg (22.1 lb) 10.4 kg (22.1 lb) 2.5°/1.9 mm (0.0748 in) 2.5°/1.9 mm (0.0748 in)
Direction of Winding (Top view) IN. EX.	
Piston: Piston Size "D" Measuring Point "H" 	58.940 ~ 58.955 mm (2.321 ~ 2.322 in) 5 mm (0.197 in) (From bottom line of piston skirt)

# MAINTENANCE SPECIFICATIONS

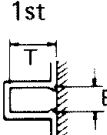
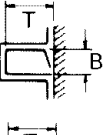
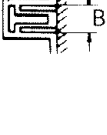
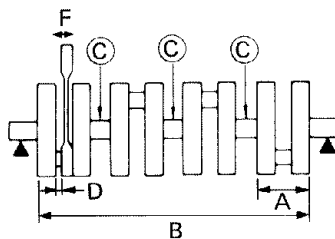

Model	FZR600RB/RBC
Piston-to-Cylinder Clearance < Limit > Oversize:	0.045 ~ 0.070 mm (0.0018 ~ 0.0028 in) < 0.15 mm (0.006 in) > 59.5 mm (2.343 in)
Piston Ring: Sectional Sketch <div style="display: flex; flex-direction: column; align-items: center;"> <div style="display: flex; align-items: center; margin-bottom: 10px;"> <div style="text-align: center; margin-right: 10px;">1st</div>  <div style="margin-left: 10px;">Top Ring</div> </div> <div style="display: flex; align-items: center; margin-bottom: 10px;"> <div style="text-align: center; margin-right: 10px;">2nd Ring</div>  <div style="margin-left: 10px;">2nd Ring</div> </div> <div style="display: flex; align-items: center;"> <div style="text-align: center; margin-right: 10px;">Oil Ring</div>  <div style="margin-left: 10px;">Oil Ring</div> </div> </div>	Barrel B = 0.8 mm (0.0315 in) T = 2.1 mm (0.0827 in)  Taper B = 0.8 mm (0.0315 in) T = 2.1 mm (0.0827 in)  Expander B = 1.5 mm (0.0591 in) T = 2.2 mm (0.0866 in)
End Gap (Installed):	Top Ring < Limit > 0.15 ~ 0.30 mm (0.0059 ~ 0.0118 in) 0.6 mm (0.0236 in) 2nd Ring < Limit > 0.15 ~ 0.30 mm (0.0059 ~ 0.0118 in) 0.6 mm (0.0236 in) Oil Ring 0.2 ~ 0.6 mm (0.0079 ~ 0.0236 in)
Side Clearance:	Top Ring < Limit > 0.03 ~ 0.07 mm (0.0012 ~ 0.0028 in) 0.10 mm (0.004 in) 2nd Ring < Limit > 0.02 ~ 0.06 mm (0.0008 ~ 0.0024 in) 0.10 mm (0.004 in) Oil Ring —
Connecting Rod: Connecting Rod Oil Clearance Bearing Size No. Color Code	0.043 ~ 0.066 mm (0.0017 ~ 0.0026 in) < Limit > 0.08 mm (0.0031 in) 1. Blue 2. Black 3. Brown 4. Green
Crankshaft: <div style="text-align: center; margin: 10px 0;">  </div> Crank Width "A" Assembly Width "B" Runout Limit "C" Big End Side Clearance "D" Small End Free Play "F"	48.4 mm (1.9055 in) 296.8 ~ 298.0 mm (11.685 ~ 11.732 in) 0.03 mm (0.0012 in) 0.160 ~ 0.262 mm (0.0063 ~ 0.0103 in) 0.32 ~ 0.50 mm (0.0126 ~ 0.0197 in)
Main Journal Oil Clearance: Bearing Size No. Color Code:	0.025 ~ 0.043 mm (0.0010 ~ 0.0017 in) 1. Blue 2. Black 3. Brown 4. Green 5. Yellow
Thrust Bearing Position:	#5 JOURNAL

# MAINTENANCE SPECIFICATIONS



Model	FZR600RB/RBC	
	FZR600RB	FZR600RBC
<b>Carburetor:</b>		
Type/Manufacture x Quantity	BDST32/MIKUNI x 4	←
I.D. Mark	3HH-03	3UU-03
Main Jet (M.J.)	# 107.5	←
Main Air Jet (M.A.J.)	# 65	←
Jet Needle-Clip Position (J.N.)	5CFZ7-1	←
Needle Jet (N.J.)	Y-0	←
Pilot Jet (P.J.)	# 32.5	←
Pilot Outlet Size (P.O.)	0.8	←
Pilot Air Jet (P.A.J.)	# 132.5	←
Pilot Screw (P.S.)	3.0	←
Valve Seat Size (V.S.)	1.2	←
Starter Jet (G.S. <sub>1</sub> )	# 52.5	# 50
	(G.S. <sub>2</sub> )	0.6
Bypass 1 (B.P. 1)	0.8	←
Bypass 2 (B.P. 2)	0.8	←
Throttle Valve Size (Th. V)	# 130	←
Fuel Level (F.L.)	3.8 ~ 4.8 mm (0.15 ~ 0.19 in) Above the float chamber line	
Engine Idle Speed	1.150 ~ 1.250 r/min	
<b>Fuel Pump:</b>		
Type	Electrical Type	
Model/Manufacturer	3EN/MITSUBISHI	
Consumption Amperage < Max. >	0.8A	
Output Pressure	7 kPa (0.07 kg/cm <sup>2</sup> , 0.995 psi)	
<b>Lubrication System:</b>		
Oil Filter Type	Paper	
Oil Pump Type	Trochoid pump	
Tip Clearance	0.03 ~ 0.09 mm (0.0012 ~ 0.0035 in)	
< Limit >	< 0.15 mm (0.006 in) >	
Side Clearance	0.03 ~ 0.08 mm (0.0012 ~ 0.0031 in)	
< Limit >	< 0.15 mm (0.006 in) >	
Oil Pressure (Hot)	80 kPa (0.8 kg/cm <sup>2</sup> , 11.4 psi)/1.200 r/min	
Pressure Check Location	Main Gallery	
Bypass Valve Setting Pressure	80 ~ 120 kPa (0.8 ~ 1.2 kg/cm <sup>2</sup> , 11.38 ~ 17.06 psi)	
Relief Valve Operating Pressure	450 ~ 550 kPa (4.5 ~ 5.5 kg/cm <sup>2</sup> , 63.99 ~ 78.21 psi)	



Model







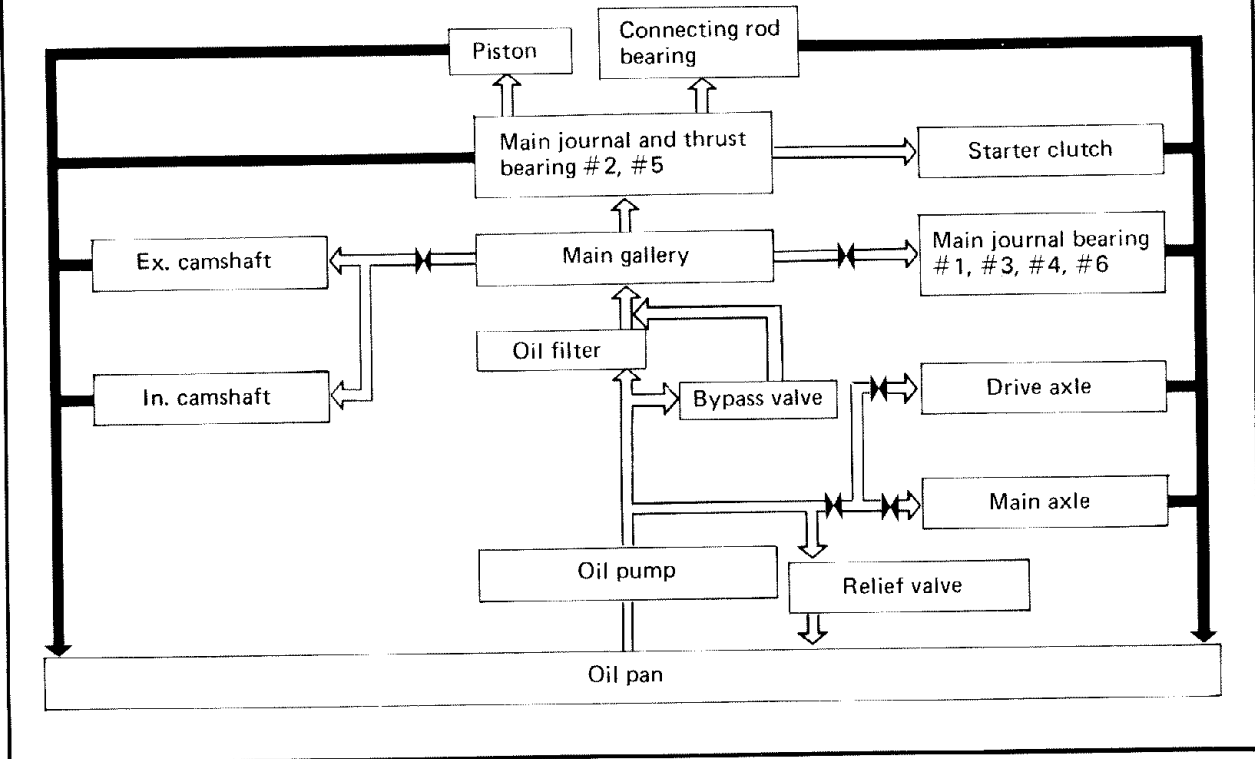











FZR600RB/RBC

Lubrication Chart:

- ⇨ Pressured feed
- ➔ Splashed
- ⌘ Nozzle



**Tightening torque**

Part to be tightened	Part name	Thread size	Q'ty	Tightening torque			Remarks
				Nm	m · kg	ft · lb	
Camshaft Cap	Bolt	M6	24	10	1.0	7.2	
Stud Bolt (Cylinder head)	—	M6	8	10	1.0	7.2	
Cylinder Head	Nut	M8	12	25	2.5	18	
Spark Plug	—	M10	4	13	1.3	9.4	
Cylinder Head Cover	Bolt	M6	8	10	1.0	7.2	
Blind Plug (Sand)	Screw	M12	6	37	3.7	27	
Blind Plug (Water)	Screw	M6	2	7	0.7	5.1	
Connecting Rod	Nut	M7	8	23	2.3	17	
Timing Chain Sprocket	Bolt	M7	4	24	2.4	17	
Timing Chain Tensioner	Bolt	M6	2	10	1.0	7.2	
Timing Chain Guide (Intake)	Bolt	M6	2	10	1.0	7.2	
Timing Chain Tensioner End	Bolt	M6	1	10	1.0	7.2	
Pipe Stopper	Bolt	M6	4	10	1.0	7.2	
Thermostat Housing Assembly	Bolt	M6	2	7	0.7	5.1	
Thermostat Housing Cover	Bolt	M6	2	10	1.0	7.2	
Radiator	Bolt	M6	2	7	0.7	5.1	
Water Pipe Joint	Bolt	M6	4	10	1.0	7.2	
Water Pump	Bolt	M6	2	10	1.0	7.2	
Water Pump Cover	Bolt	M6	2	10	1.0	7.2	
Radiator Cover	Screw	M5	4	7	0.7	5.1	
Oil Pump Housing	Screw	M6	1	7	0.7	5.1	
Oil Pump Mount	Bolt	M6	3	10	1.0	7.2	
Drain Plug	Bolt	M14	1	43	4.3	31	
Oil Delivery Pipe	Bolt	M10	2	20	2.0	14	
Carburetor Joint	Bolt	M6	8	10	1.0	7.2	
Exhaust Pipe	Nut	M6	8	10	1.0	7.2	
Muffler Bracket	Bolt	M8	1	20	2.0	14	
Exhaust Pipe Blind Plug (CO test)	Bolt	M6	4	10	1.0	7.2	
Exhaust Pipe Joint	Bolt	M8	2	20	2.0	14	
Crankcase	Bolt	M8	12	24	2.4	17	
Stud Bolt (Crankcase)	—	M8	12	13	1.3	9.4	
Crankcase	Bolt	M6	21	12	1.2	8.7	
	Bolt	M8	1	24	2.4	17	
Oil Baffle Plate	Screw	M6	4	7	0.7	5.1	
Crankcase Cover (Left)	Bolt	M6	5	10	1.0	7.2	
Crankcase Cover (Right)	Bolt	M6	10	10	1.0	7.2	
Bearing Plate	Bolt	M6	2	10	1.0	7.2	
Generator Cover	Bolt	M6	5	10	1.0	7.2	
Starter Clutch Cover	Bolt	M6	7	10	1.0	7.2	
Starter Clutch	Bolt	M10	1	80	8.0	58	
Starter Clutch Outer and Starter Wheel	Bolt	M8	3	30	3.0	22	
Pressure Plate	Bolt	M5	5	6	0.6	4.3	
Clutch Boss	Nut	M18	1	70	7.0	51	Use lock washer
Push Lever	Screw	M5	2	5	0.5	3.6	
Push Rod	Nut	M8	1	16	1.6	11	
Drive Sprocket	Nut	M18	1	70	7.0	51	Use lock washer
Stopper Plate	Bolt	M6	1	10	1.0	7.2	
Stopper Lever	Bolt	M6	1	10	1.0	7.2	



CHASSIS

Model	FZR600RB/RBC						
Rear Suspension:							
Shock Absorber Travel	43 mm (1.69 in)						
Spring Free Length	180.5 mm (7.11 in)						
< Limit >	170.5 mm (6.71 in)						
Fitting Length	170 mm (6.69 in)						
Spring Rate	K1	130 N/mm (13 kg/mm, 728 lb/in)					
Stroke	K1	0 ~ 43 mm (0.0 ~ 1.69 in)					
Optional Spring	No						
Enclosed Gas Pressure:	1.200 kPa (12 kg/cm <sup>2</sup> , 171 psi)						
Standard							
		Hard			STD	Soft	
Adjusting position	7	6	5	4	3	2	1
Rear Wheel:							
Type	Cast wheel						
Rim Size	MT4.00 x 18						
Rim Material	Aluminum						
Rim Runout Limit	Radial	2.0 mm (0.08 in)					
	Lateral	2.0 mm (0.08 in)					



Parts to be tightened	Thread size	Tightening torque		
		Nm	m · kg	ft · lb
Front Axle and Outer Tube	M14 x 1.5	58	5.8	42
Front Wheel Axle Holder	M8 x 1.25	20	2.0	14
Rear Axle and Nut	M16 x 1.5	107	10.7	77
Handlebar Crown and Inner Tube	M8 x 1.25	26	2.6	19
Handlebar Crown and Steering Stem	M22 x 1.0	110	11.0	80
Steering ring nut (Upper and lower)	—	See "NOTE"		
Brake Caliper (Front/Rear)	M10 x 1.25	35	3.5	25
Bleed Screw and Brake Caliper	M8 x 1.25	6	0.6	4.3
Brake Hose and Union Bolt	M10 x 1.25	26	2.6	19
Front Master Cylinder and Master Cylinder Holder	M6 x 1.0	9	0.9	6.5
Front Master Cylinder and Cylinder Cap	M5 x 0.8	2	0.2	1.4
Front Fender and Outer Tube	M6 x 1.0	6	0.6	4.3
Handlebar Boss and Front Fork	M6 x 1.0	13	1.3	9.4
Handlebar and Handlebar Boss	M8 x 1.25	23	2.3	17
Engine Mounting: Front	M10 x 1.25	55	5.5	40
Rear – Upper	M10 x 1.25	60	6.0	43
Rear – Lower	M10 x 1.25	55	5.5	40
Down Tube and Frame: Front	M10 x 1.25	60	6.0	43
Rear	M8 x 1.25	33	3.3	24
Footrest Bracket and Frame	M8 x 1.25	22	2.2	16
Pivot Axle and Nut	M14 x 1.5	90	9.0	65
Relay Arm and Frame	M10 x 1.25	40	4.0	29
Connecting Rod and Swingarm	M10 x 1.25	40	4.0	29
Connecting Rod and Relay Arm	M10 x 1.25	40	4.0	29
Rear Shock Absorber and Relay Arm	M10 x 1.25	40	4.0	29
Rear Shock Absorber and Frame	M10 x 1.25	40	4.0	29
Footrest and Footrest Bracket	M10 x 1.25	55	5.5	40
Rear Footrest Bracket and Frame	M8 x 1.25	32	3.2	23
Rear Master Cylinder and Rear Arm Bracket	M8 x 1.25	20	2.0	14
Cowling and Stay	M6 x 1.0	4	0.4	2.9
Compression Bar and Brake Caliper Bracket	M8 x 1.25	23	2.3	17
Front Fork Pinch Bolt: Upper	M8 x 1.25	26	2.6	19
Lower	M12 x 1.25	38	3.8	27
Sprocket and Clutch Hub	M8 x 1.25	60	6.0	43
Brake Disc and Clutch Hub	M8 x 1.25	20	2.0	14
Inner Tube and Steering Stem	M8 x 1.25	22	2.2	16
Frame and Rear Frame: Upper	M10 x 1.25	64	6.4	46
Lower	M12 x 1.25	88	8.8	64

**NOTE:**

1. First, tighten the ring nut (lower) approximately 52 Nm (5.2 m · kg, 37 ft · lb) by using the torque wrench, then loosen the ring nut one turn.
2. Retighten the ring nut (lower) approximately 3 Nm (0.3 m · kg, 2.2 ft · lb).
3. Install the ring nut (upper). And finger tighten the ring nut (upper), then align the slots of both ring nuts. If not aligned, hold the lower ring nut and tighten the other until they are aligned.



**ELECTRICAL**

Model	FZR600RB/RBC
Voltage:	12V
Ignition System: Ignition Timing (B.T.D.C.)	5° at 1,200 r/min, 5° at 1,300 r/min (FZR600RBC)
Advancer Type	Electrical
T.C.I.: Pickup Coil Resistance (Color) T.C.I. Unit/Manufacturer	80 ~ 120Ω at 20°C (68°F) (White/Red – White/Black) BB7233/HITACHI TID14-73/HITACHI (FZR600RBC)
Rectifier: Model/Manufacturer Capacity Withstand Voltage	SH569/SHINDENGEN 25A 240V
Electrical Starter System: Type Starter Motor: Model/Manufacturer Output Brush – Overall Length < Limit > Commutator Dia. Wear Limit Mica Undercut Starter Switch: Model/Manufacturer Amperage Rating Coil Winding Resistance	Constant mesh type SM-13/MITSUBA 0.7 kW 12.5 mm (0.49 in) 4 mm (0.16 in) 28 mm (1.10 in) 27 mm (1.06 in) 0.7 mm (0.027 in) A104-128/HITACHI 100A 3.87 ~ 4.73Ω at 20°C (68°F)
Horn: Type/ Model/Manufacturer Maximum Amperage	Plane Type/1 pcs. YF-12/NIKKO 2.5A, 1.5A (FZR600RBC)
Flasher Relay (Relay Assembly): Type Model/Manufacturer Self Cancelling Device Flasher Frequency Wattage	Semi transistor type FB257N/NIPPONDENSO Yes 60 ~ 120 cycle/min 27W x 2 pcs + 3.4W
Thermostat Switch: Model/Manufacturer	2EL/NIPPON THERMOSTAT
Circuit Breaker: Type Amperage for Individual Circuit x Quantity: MAIN HEADLIGHT SIGNAL IGNITION RESERVE	Fuse 30A x 1 20A x 1 10A x 1 10A x 1 10A x 1, 30A x 1, 20A x 1

LUBRICATION DIAGRAM

- ① Camshaft
- ② Rotor
- ③ Stator coil
- ④ Crankshaft
- ⑤ Drain plug
- ⑥ Starter clutch
- ⑦ Oil jet nozzle
- ⑧ Oil delivery pipe

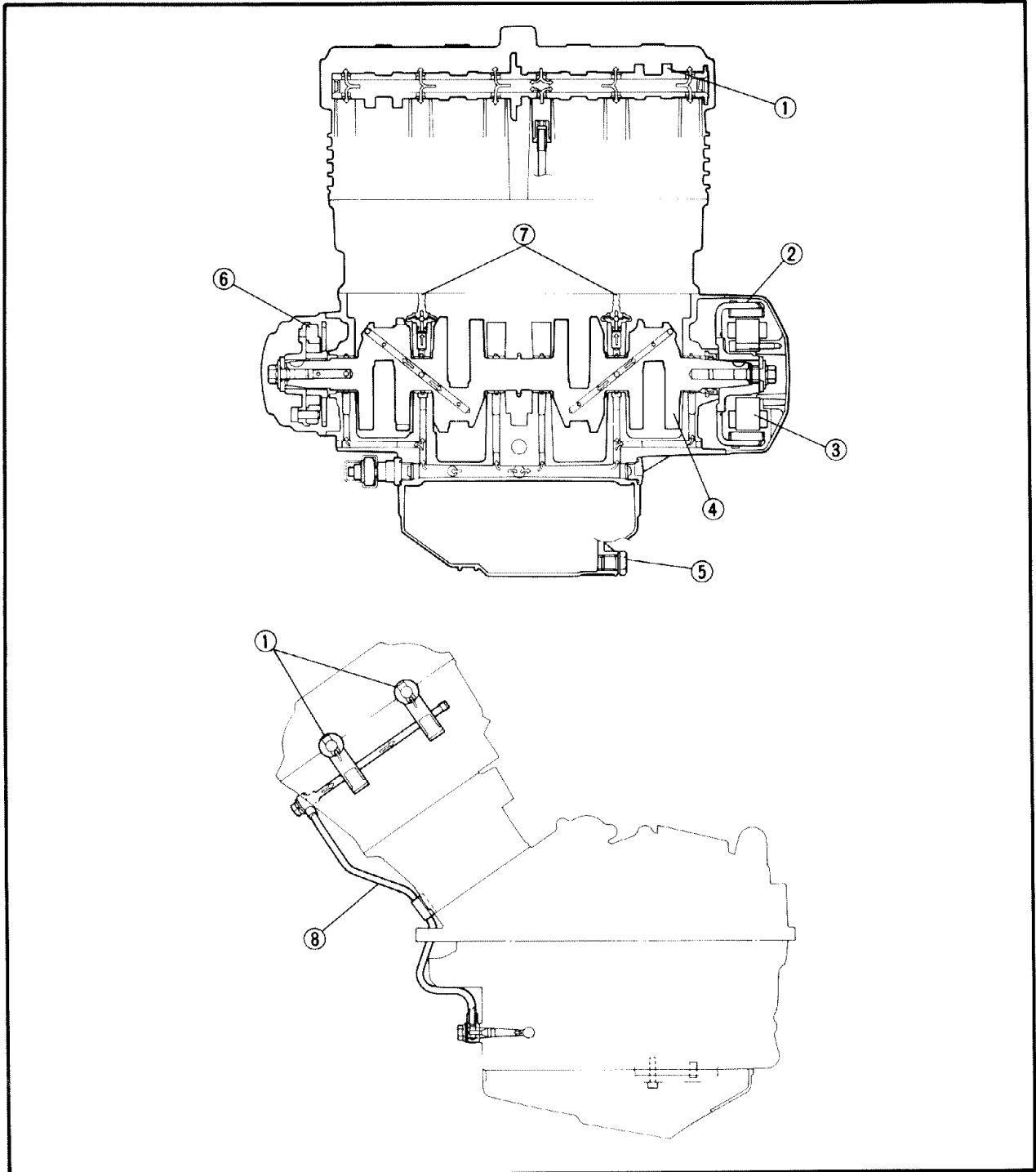

- ① Oil filter
- ② Bolt
- ③ Adapter plate
- ④ Relief valve
- ⑤ Oil strainer
- ⑥ Oil pump

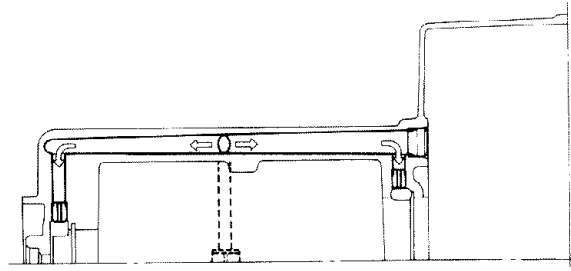

A-A

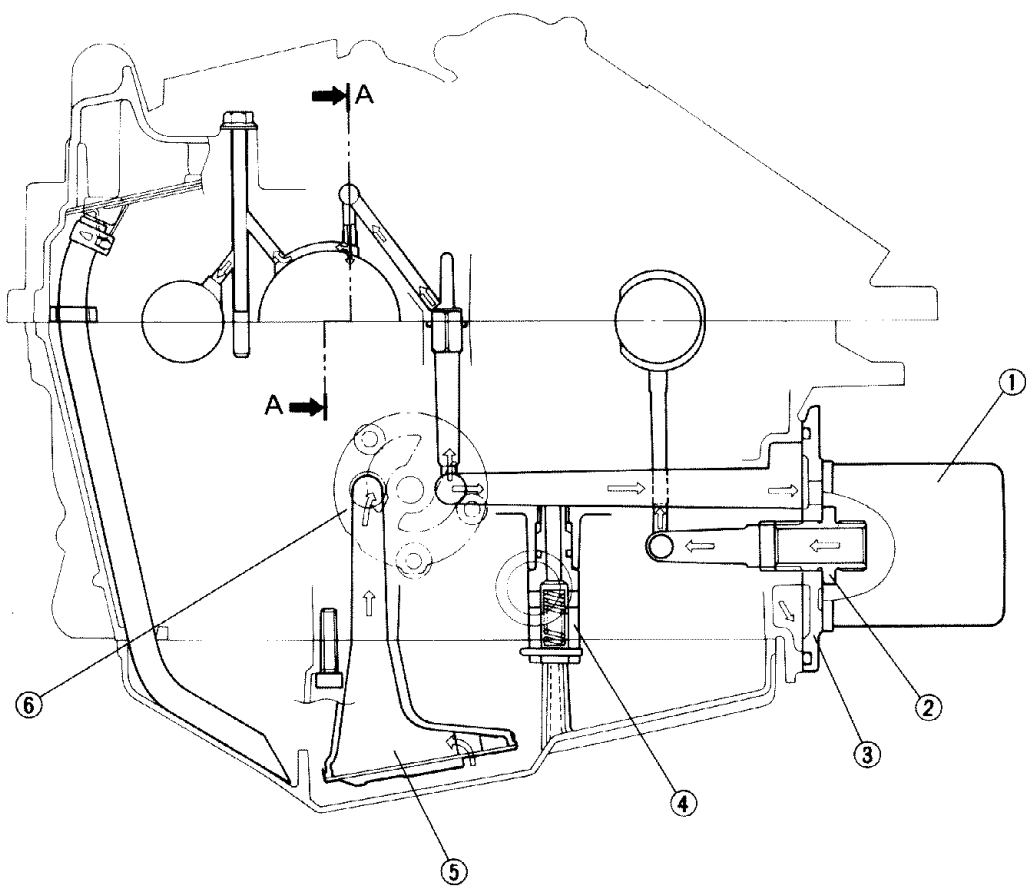

- ① Oil pump driven gear
- ② Oil pump cover
- ③ Inner rotor
- ④ Oil pump housing
- ⑤ Pump shaft
- ⑥ Main axle
- ⑦ Ball
- ⑧ Push rod # 1
- ⑨ Drive sprocket
- ⑩ Drive axle
- ⑪ Push rod # 2

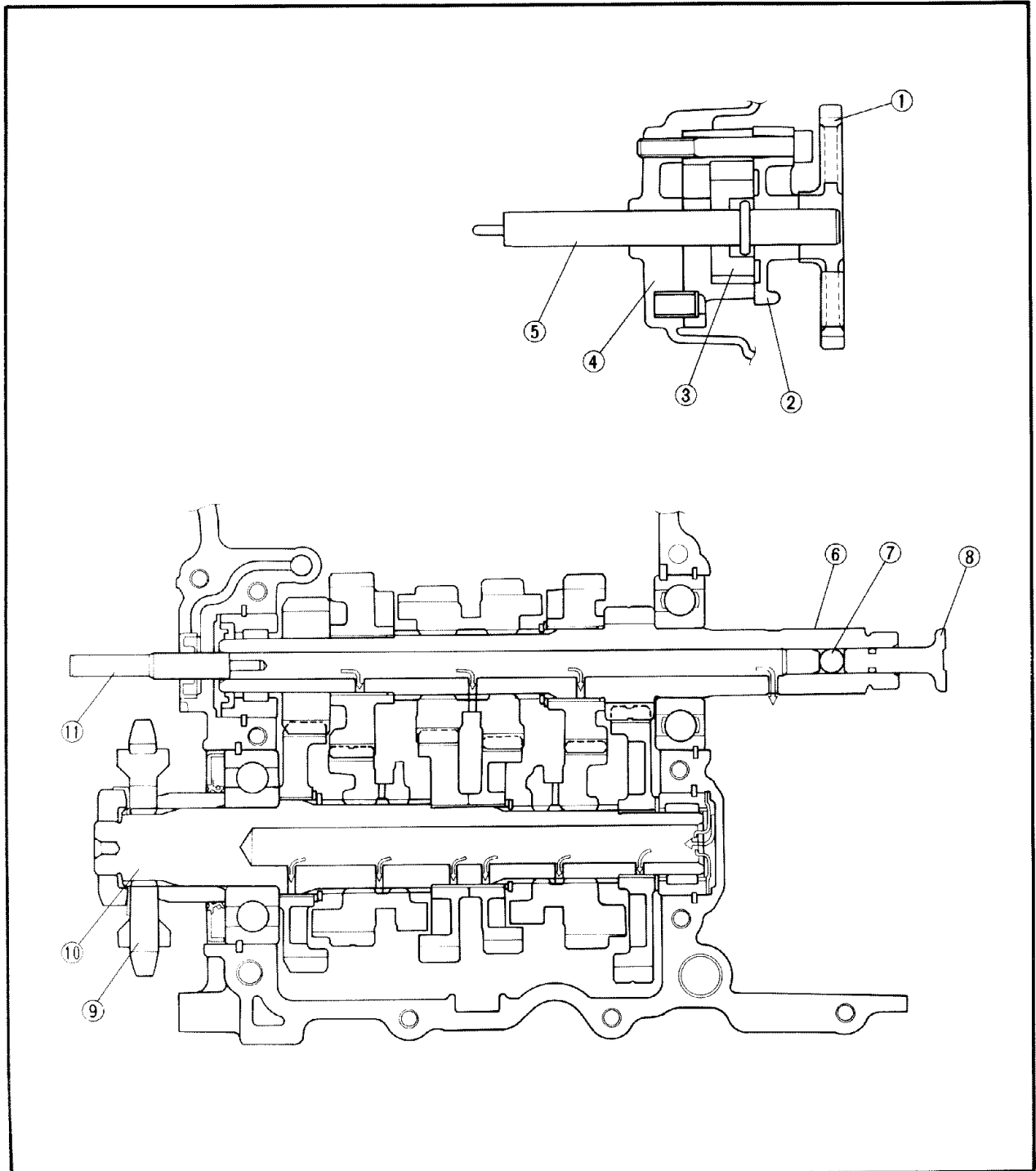



COOLANT DIAGRAM

- ① Radiator cap
- ② Thermostatic valve
- ③ Thermostatic valve housing
- ④ Reservoir tank hose
- ⑤ Coolant reservoir tank
- ⑥ Water pipe
- ⑦ Water pump
- ⑧ Drain bolt
- ⑨ Oil filter
- ⑩ Radiator hose (outlet)
- ⑪ Radiator
- ⑫ Radiator hose (inlet)

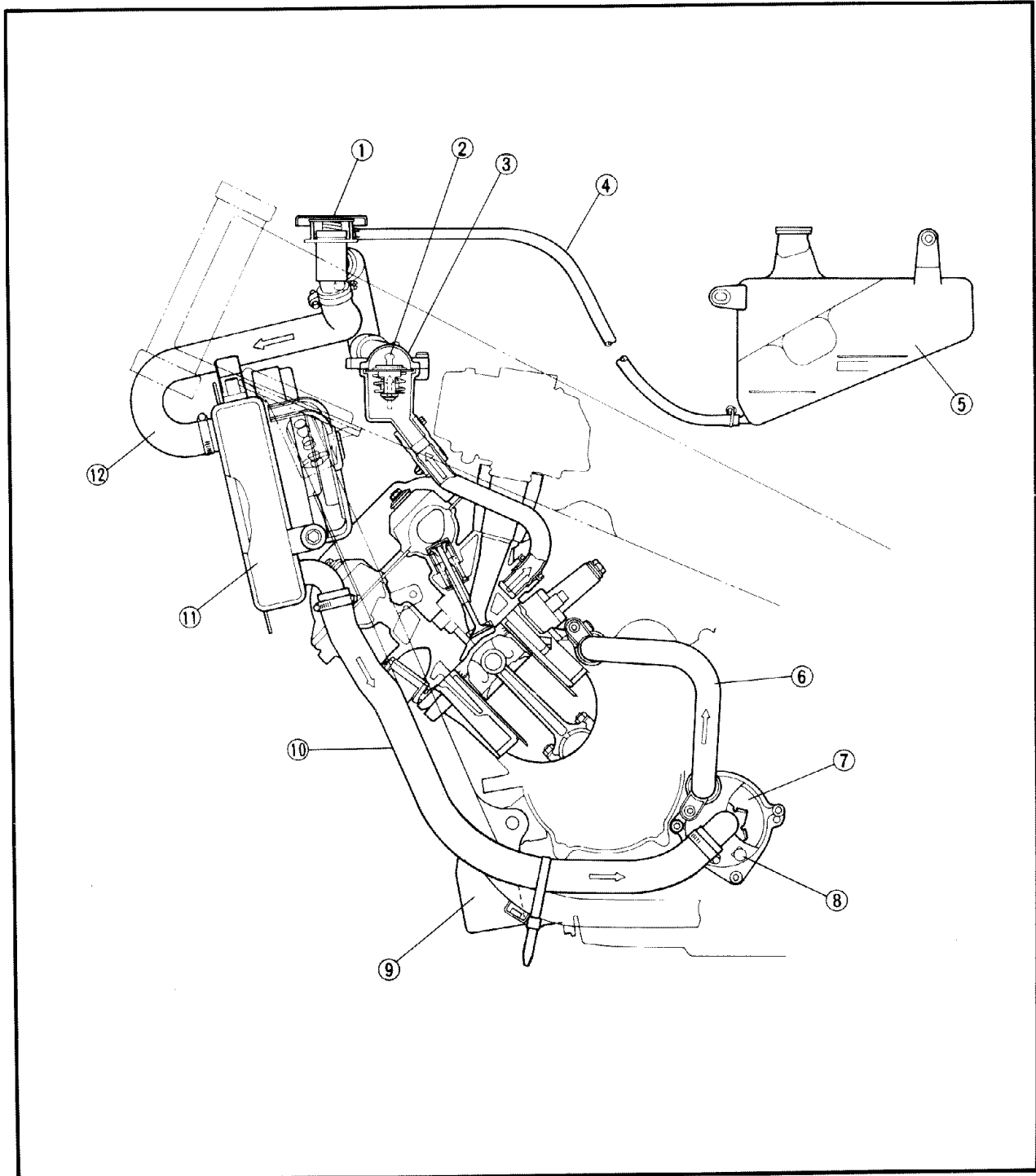

- ① Thermo switch
- ② Thermo unit
- ③ Radiator cap
- ④ Reservoir tank hose
- ⑤ Radiator hose 3
- ⑥ Radiator hose (inlet)
- ⑦ Radiator hose 2
- ⑧ Radiator pipe 1
- ⑨ Radiator
- ⑩ Fan motor assembly
- ⑪ Water jacket joint
- ⑫ Water pump housing
- ⑬ Water pump
- ⑭ Water pump cover
- ⑮ Radiator hose (outlet)
- ⑯ Radiator pipe 2
- ⑰ Radiator hose 1

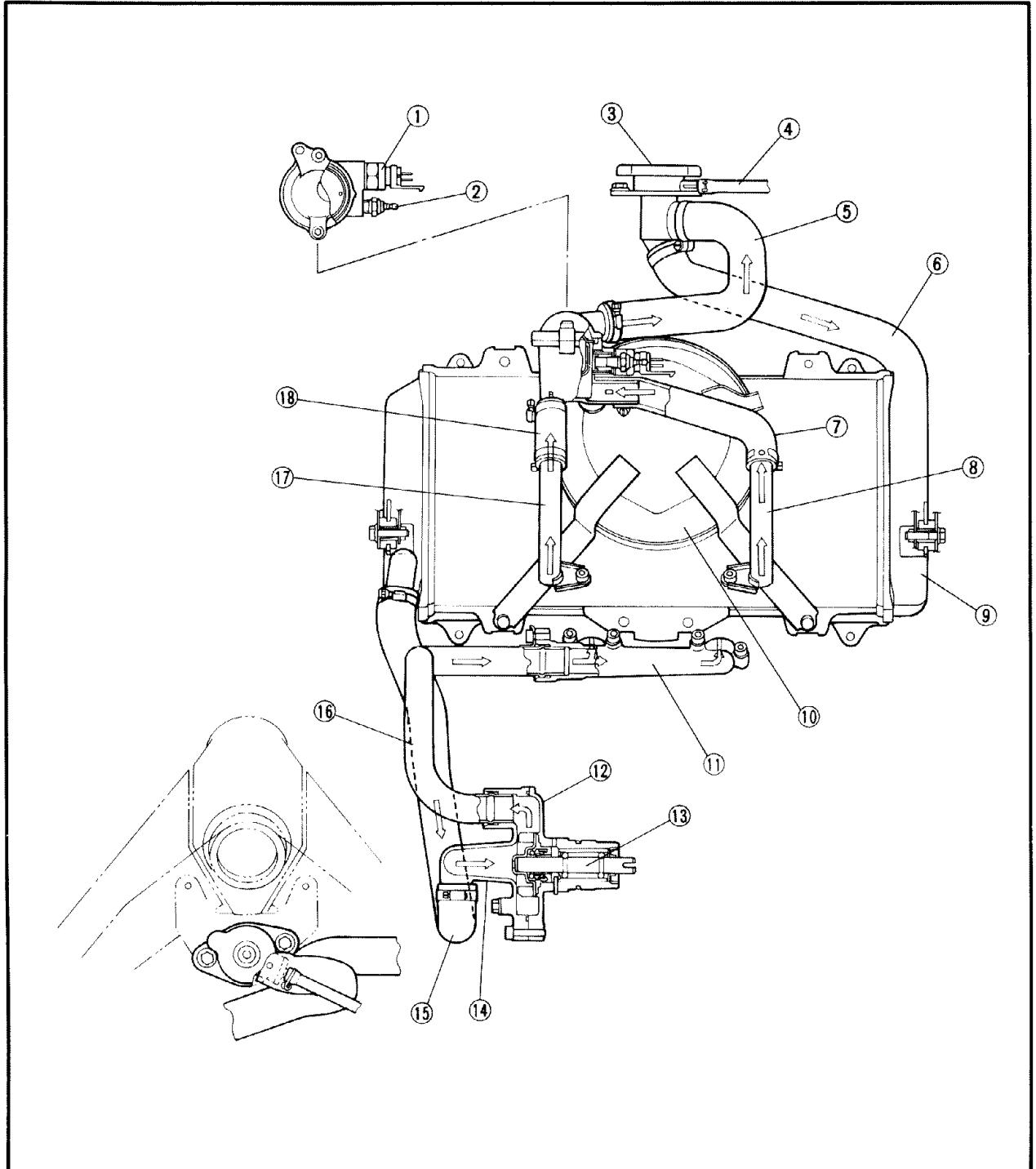



## CABLE ROUTING

- ① Front brake hose
- ② Handlebar switch (right)
- ③ Throttle cable
- ④ Clamp
- ⑤ Radiator breather hose
- ⑥ Handlebar switch (left) lead
- ⑦ Clutch cable
- ⑧ Main switch lead

- A Pass the brake hose right side of cowling stay.
- B Pass the handlebar switch (left) lead in front of inner tube.
- C Pass the throttle cables in front of brake hose.
- D Clamp the throttle cables and handlebar switch (left) lead.
- E Clamp the handlebar switch (left) and main switch leads.

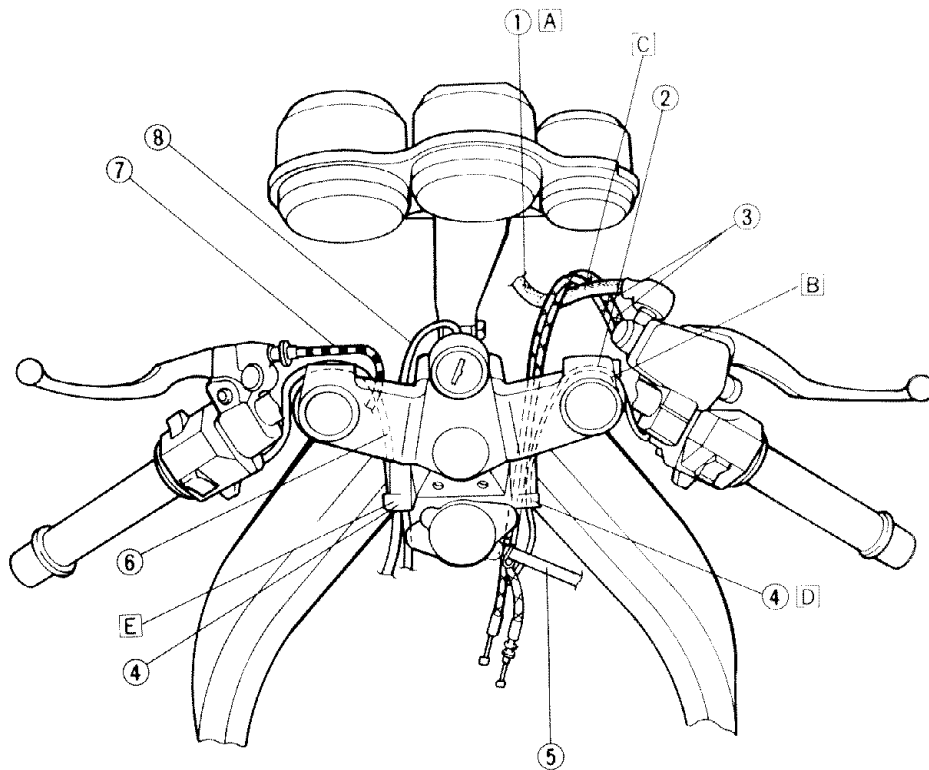

- ① Cowling stay
- ② Clamp
- ③ Flasher light (left) lead
- ④ Wireharness
- ⑤ Flasher light (right) lead
- ⑥ Meter light lead

- A Clamp the flasher light lead.
- B Clamp the wireharness.
- C Pass the headlight lead in front of the cowling stay.

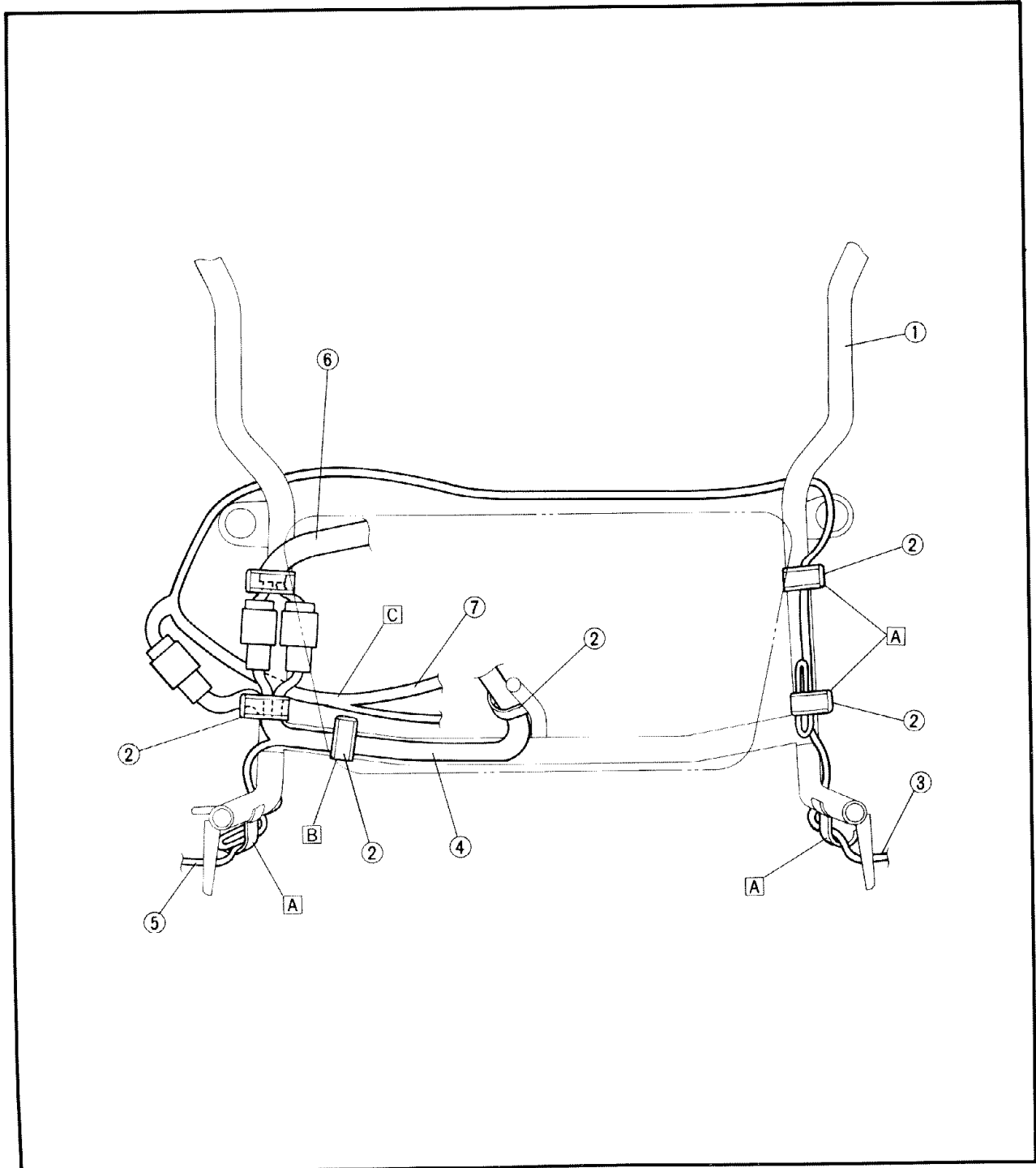

- ① Battery
- ② Coolant reservoir hose
- ③ Battery positive lead
- ④ Starter relay lead
- ⑤ Breather hose (coolant reservoir hose)
- ⑥ Taillight lead
- ⑦ Rear flasher light lead
- ⑧ Rectifier/regulator
- ⑨ Flasher relay
- ⑩ Relay assembly
- ⑪ Ignitor unit
- ⑫ Clamp
- ⑬ Band
- ⑭ Starter relay lead
- ⑮ Starter relay
- ⑯ Exup servo motor
- ⑰ Exup servo motor lead

- A Pass the flasher light lead through the hole in rear fender.
- B Clamp the taillight and rear flasher light lead.
- C Clamp the wireharness.
- D For California only

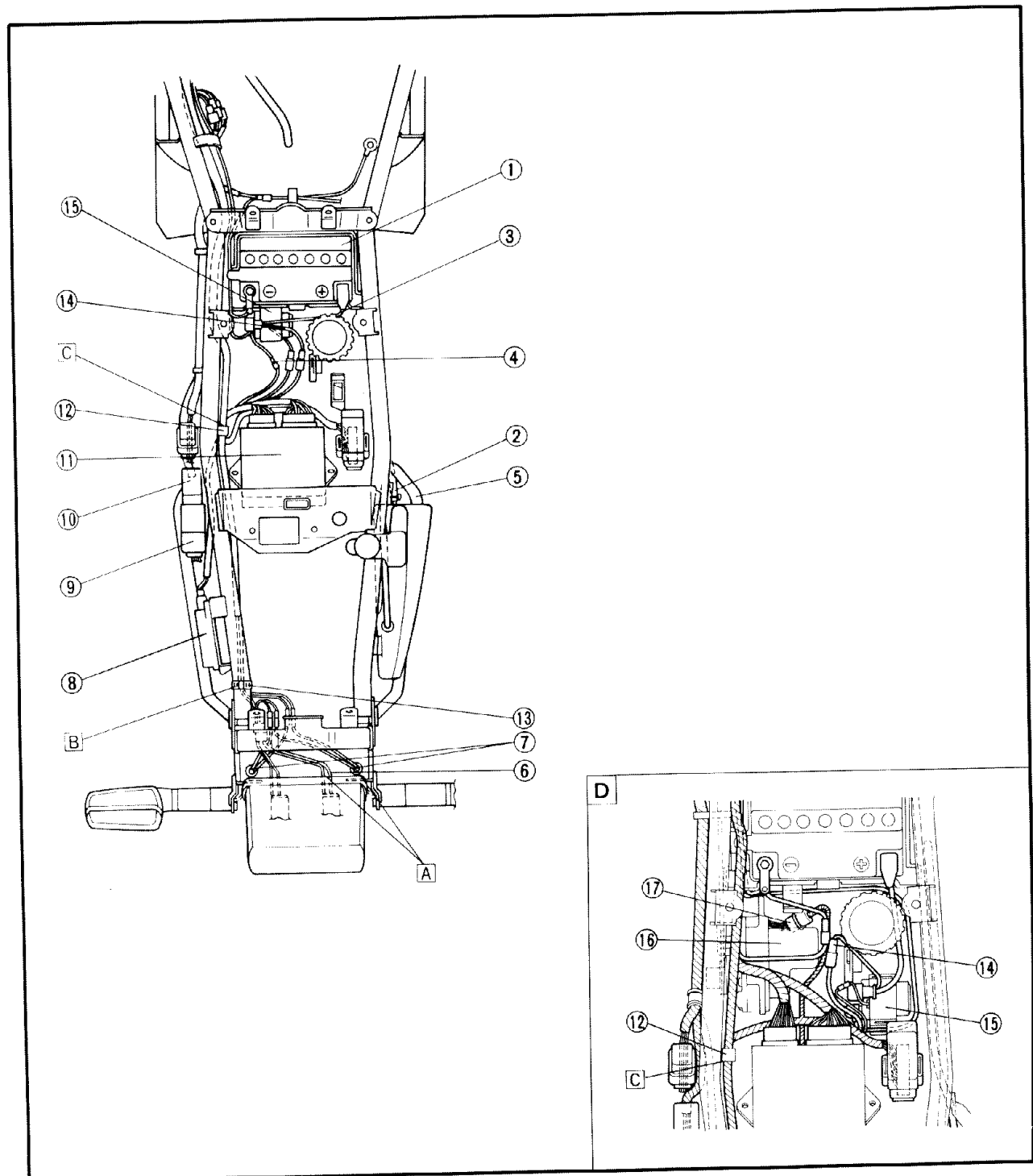

- ① Radiator hose
- ② Ignition coil
- ③ Fan motor lead
- ④ Radiator breather hose
- ⑤ Carburetor breather hose
- ⑥ Starter motor lead
- ⑦ Ground lead
- ⑧ A.C. Generator lead
- ⑨ Clamp
- ⑩ Wireharness
- ⑪ Thermo unit
- ⑫ Clutch cable
- ⑬ Handlebar switch (left) lead
- ⑭ Main switch lead
- ⑮ Handlebar switch (right) lead
- ⑯ Throttle cable

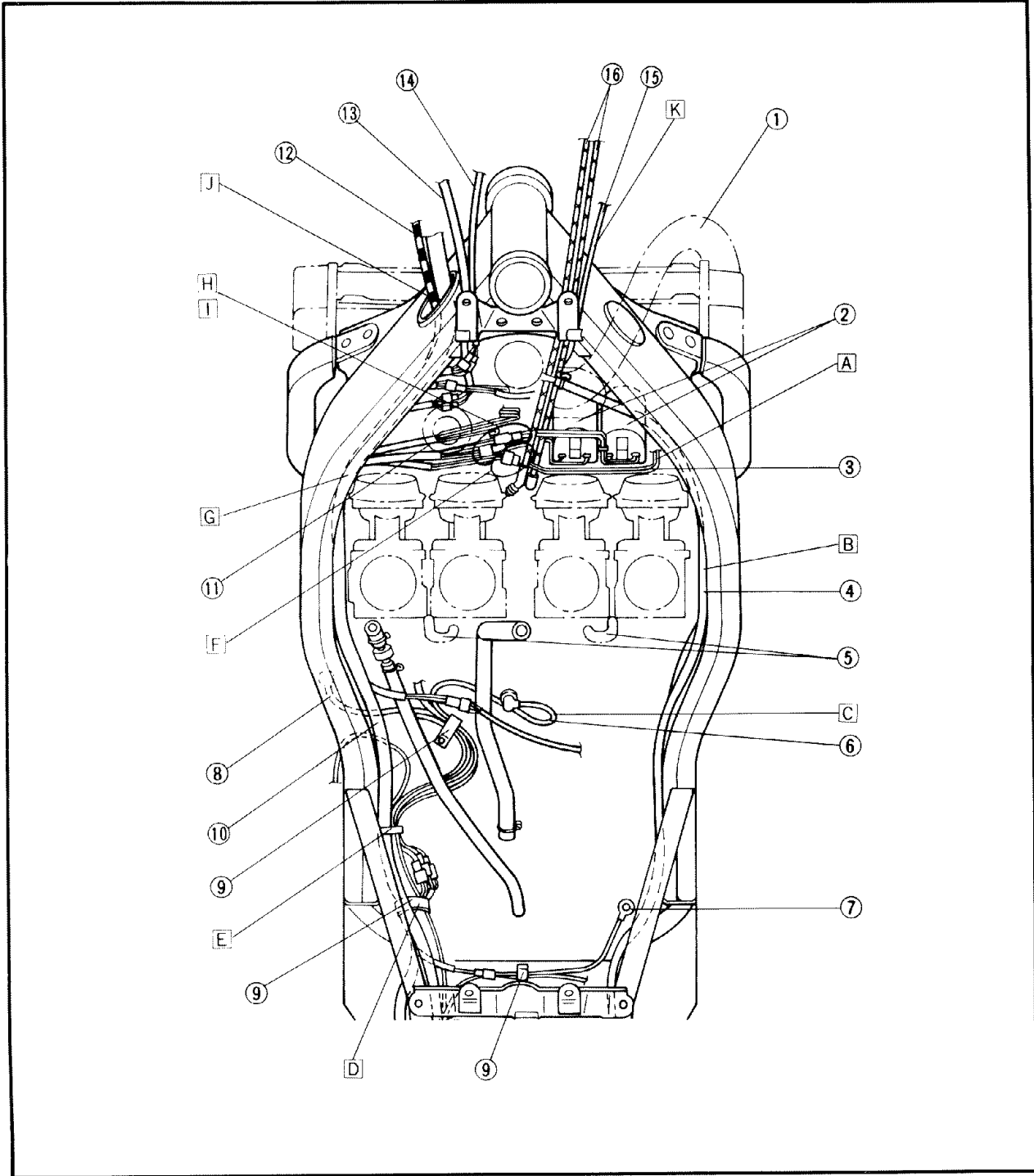

# CABLE ROUTING



- A** Pass the fan motor lead behind the ignition coil.
- B** Pass the radiator breather hose between the carburetor and frame.
- C** Pass the starter motor lead below the starter motor.
- D** Clamp the wireharness.
- E** Clamp the A.C. magneto, neutral, oil level switch and sidestand switch leads.
- F** Pass the fan motor and ignition coil leads between the throttle cables, and connect them between the conductor and thermo unit.
- G** Position the wireharness so that the white tape is positioned on thermo unit.
- H** Connect the main switch lead between the conductor and thermo unit.
- I** Locate the main switch lead coupler in front of air filter case bracket.
- J** Pass the clutch cable and wireharness through the frame hole.
- K** Pass the throttle cables and handlebar switch lead between the radiator hoses.

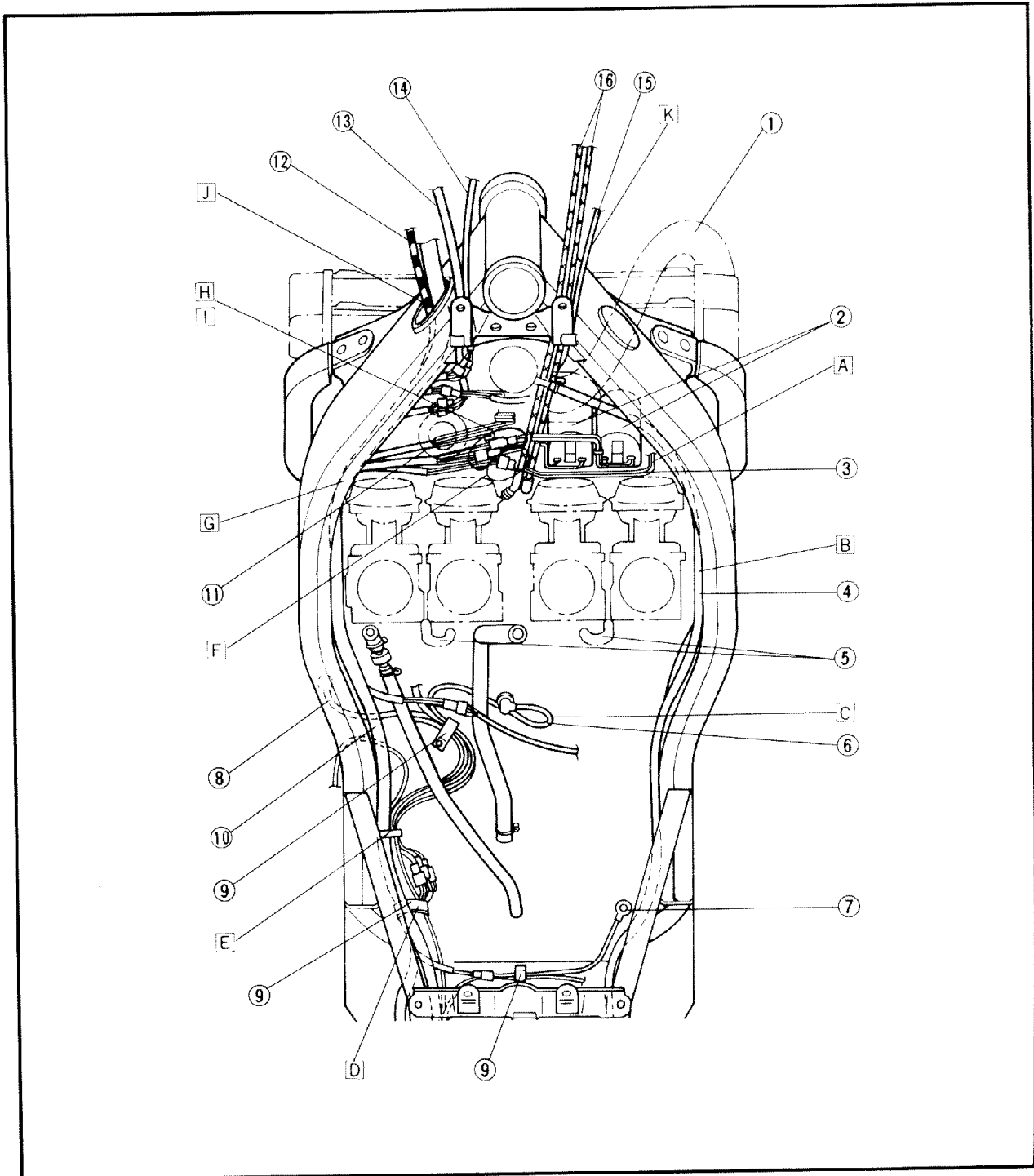



- ① Cowling stay
- ② Main switch lead
- ③ Handlebar switch (left) lead
- ④ Clutch cable
- ⑤ Thermo unit
- ⑥ Clamp
- ⑦ Sidestand switch
- ⑧ Cable guide
- ⑨ Speedometer cable
- ⑩ Front brake hose

- A Pass the wireharness above the fuel tank bracket.
- B Pass the clutch cable inside the frame.
- C Pass the air filter breather hose between the engine and swingarm.
- D Pass the starter cable behind of the air intake duct.
- E Pass the speedometer cable through the holder.
- F Pass the speedometer cable outside of the front fork.
- G Pass the brake hose inside of the front fork.
- H Pass the air filter drain hose above the engine mounting bolt, and in front of pivot shaft.
- I Clamp the sidestand, pickup coil, neutral switch, oil level switch and starter relay leads.

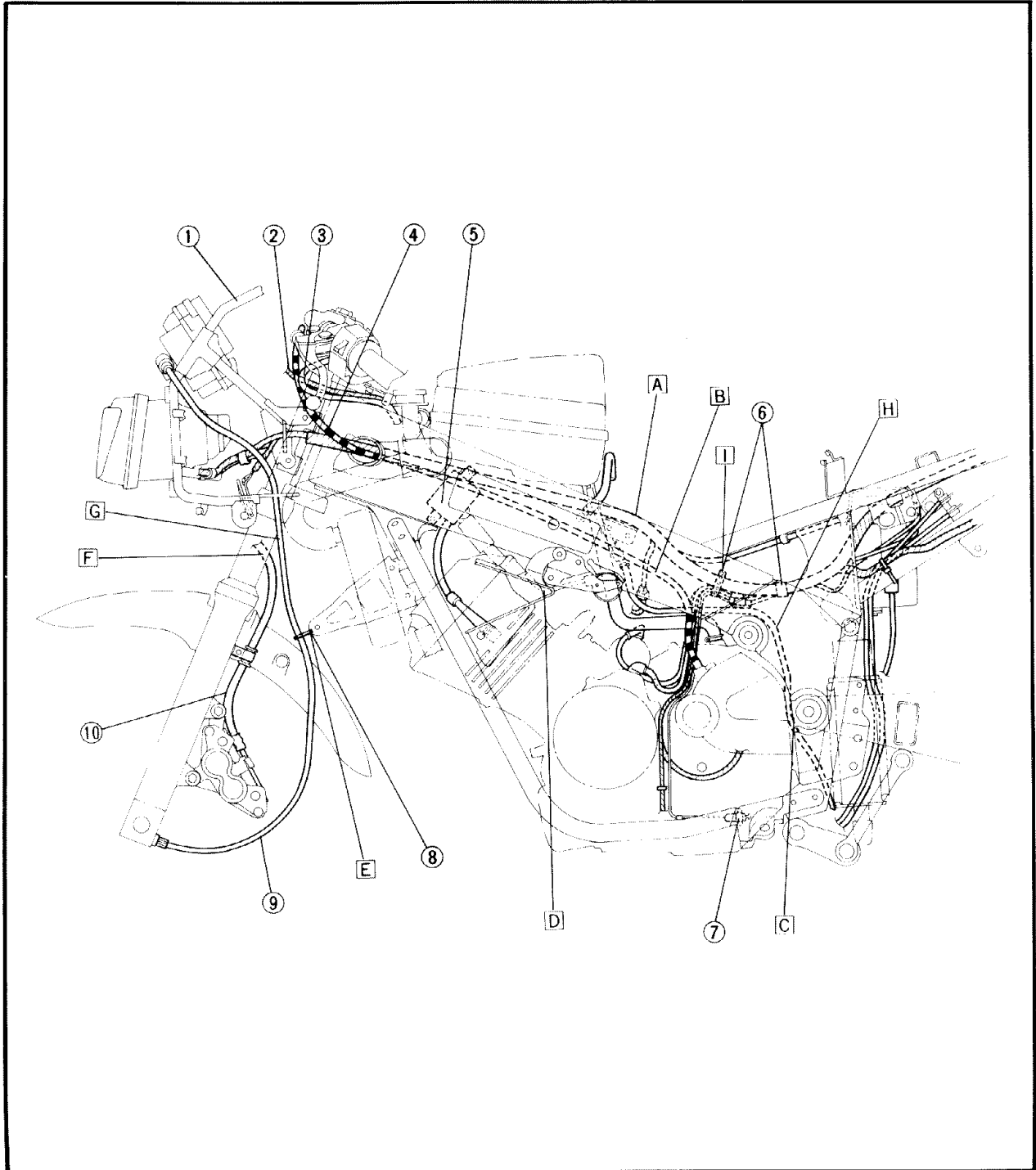

- ① Clamp
- ② Ground lead
- ③ Taillight lead
- ④ Rear flasher lead
- ⑤ Rectifier/regulator
- ⑥ Flasher relay
- ⑦ Relay assembly
- ⑧ Main fuse
- ⑨ Battery breather hose
- ⑩ "EXUP" control cable
- ⑪ "EXUP" servo motor

- A Clamp the main wireharness.
- B Clamp the rear brake switch and ground leads.
- C Secure the ground lead with the screw (rectifier/regulator).
- D Clamp the flasher light lead and taillight leads.
- E Clamp the wireharness on left side of frame.
- F Pass the wireharness above the battery box.
- G For California only

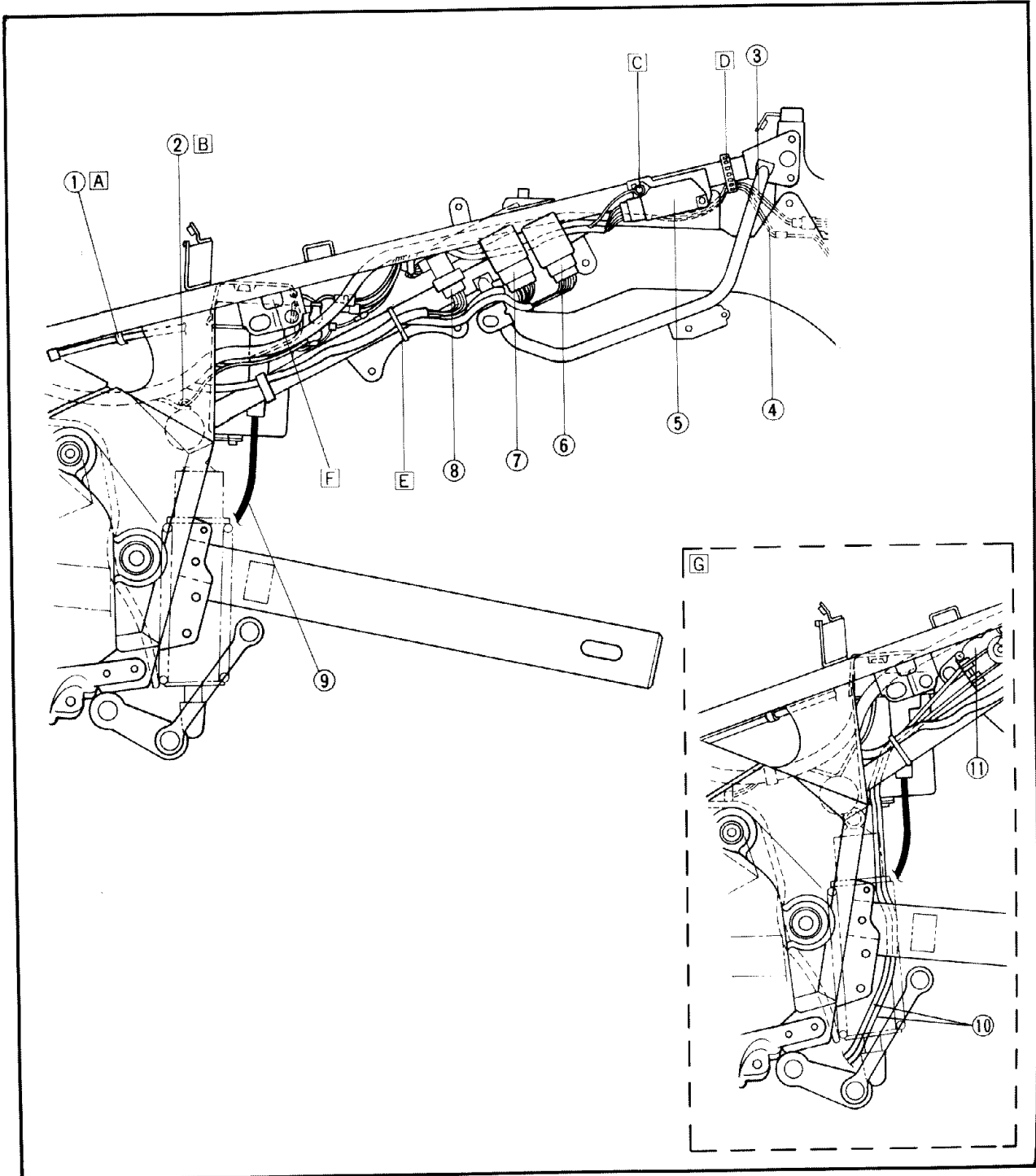

- ① Radiator hose
- ② Front brake hose
- ③ Clamp
- ④ Fan motor lead
- ⑤ Ground
- ⑥ Rear brake switch
- ⑦ Reservoir tank hose
- ⑧ Coolant reservoir tank
- ⑨ Reservoir tank (master cylinder-rear brake)

- ⑩ Battery
- ⑪ Bleeder hose (fuel filler cover)
- ⑫ Overflow hose (radiator)
- ⑬ Ignition coil
- A Pass the brake hose inside of the front fork.
- B Pass the reservoir hose inside of the back stay.
- C Pass the overflow hose (radiator) between the coolant reservoir tank and seat rail.
- D Clamp the spark plug leads (#3 and #4) together. For the spark plug lead #4, be sure to clamp on the white mark.

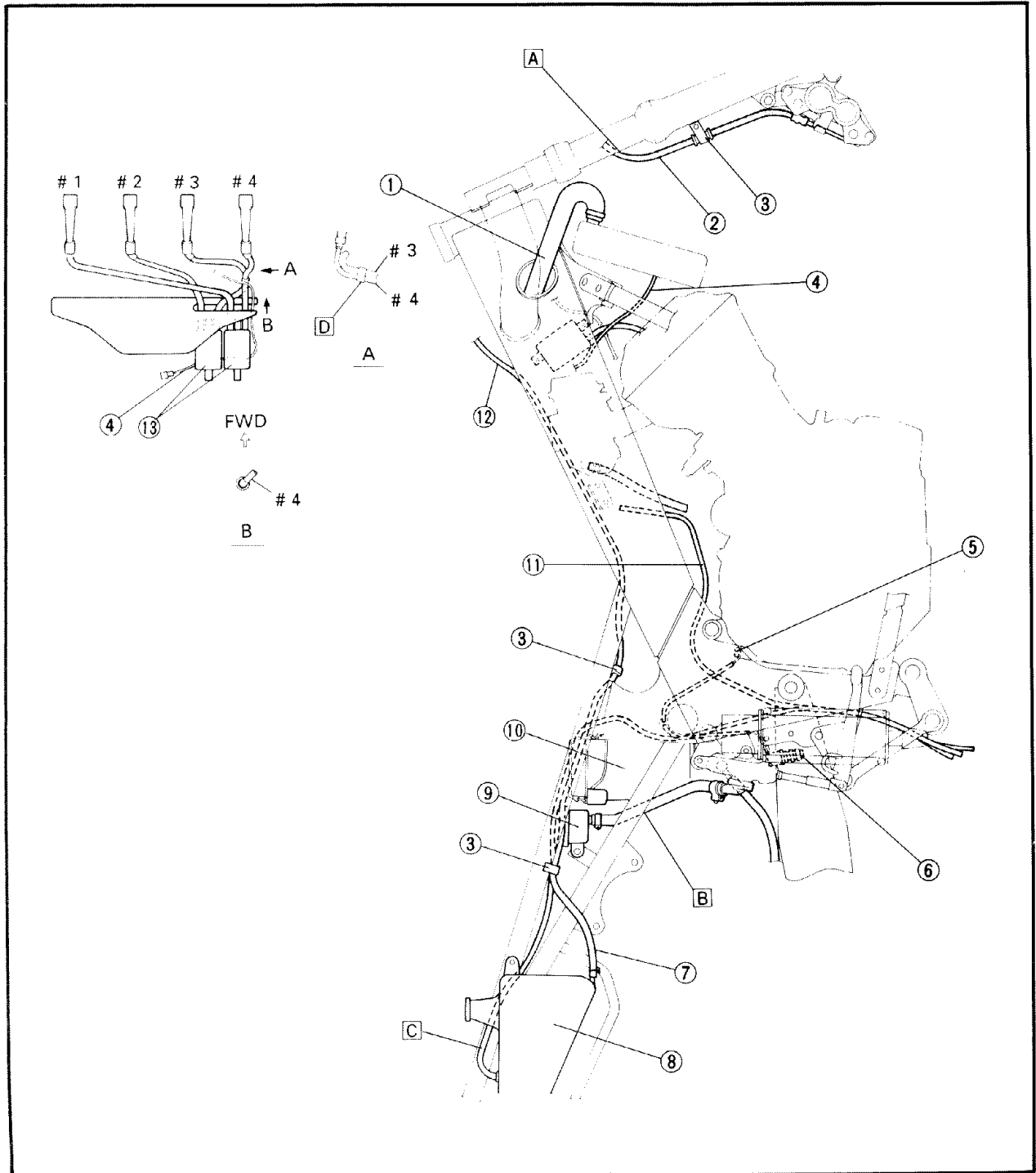



## PERIODIC INSPECTION AND ADJUSTMENT

### COWLINGS/COVERS REMOVAL AND INSTALLATION

#### REMOVAL

1. Remove:
  - Side cowlings (left ① and right ②)

- ③ Bolt
- ④ Plastic washer
- ⑤ Spring nut
- ⑥ Special nut
- ⑦ Collar
- ⑧ Damper

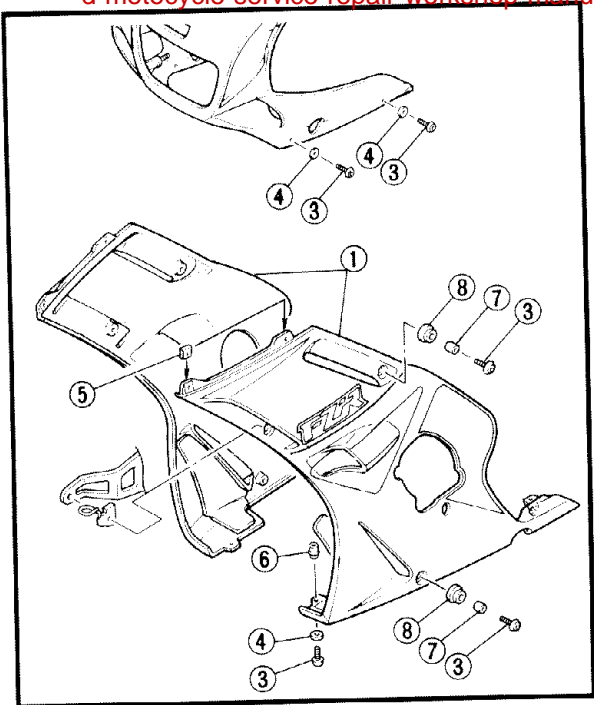

2. Remove:

- Duct covers (left and right) ①
- Flasher lights (left and right) ②
- Rear view mirror (left and right) ③

- ④ Screw
- ⑤ Nut
- ⑥ Cap
- ⑦ Damper

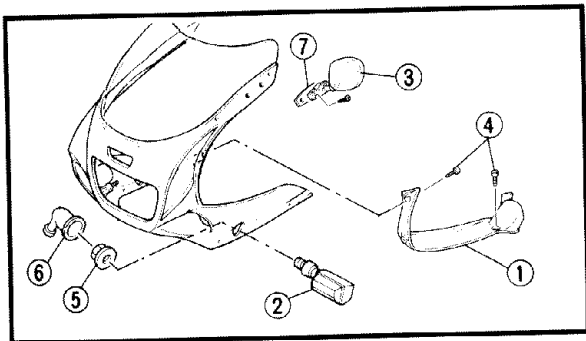

3. Remove:

- Upper cowling ①

#### CAUTION:

Remove the headlight together with the upper cowling to prevent the headlight from falling out.

4. Remove:

- Air intake ducts (left and right) ②

#### NOTE:

Align the projections (a) on the duct with the slots (b) in the frame.

- ③ Nut

