

Product: 2005-2007 Suzuki GSX-R750 Motorcycle Service Repair Workshop Manual  
Full Download: <https://www.arepairmanual.com/downloads/2005-2007-suzuki-gsx-r750-motorcycle-service-repair-workshop-manual/>

**SUZUKI**

**GSX-R750**

**SERVICE MANUAL**

Sample of manual. Download All 522 pages at:

<https://www.arepairmanual.com/downloads/2005-2007-suzuki-gsx-r750-motorcycle-service-repair-workshop-manual/>



## FOREWORD

*This manual contains an introductory description on the SUZUKI GSX-R750 and procedures for its inspection/service and overhaul of its main components.*

*Other information considered as generally known is not included.*

*Read the GENERAL INFORMATION section to familiarize yourself with the motorcycle and its maintenance. Use this section as well as other sections to use as a guide for proper inspection and service.*

*This manual will help you know the motorcycle better so that you can assure your customers of fast and reliable service.*

*\* This manual has been prepared on the basis of the latest specifications at the time of publication. If modifications have been made since then, differences may exist between the content of this manual and the actual motorcycle.*

*\* Illustrations in this manual are used to show the basic principles of operation and work procedures. They may not represent the actual motorcycle exactly in detail.*

*\* This manual is written for persons who have enough knowledge, skills and tools, including special tools, for servicing SUZUKI motorcycles. If you do not have the proper knowledge and tools, ask your authorized SUZUKI motorcycle dealer to help you.*

### **⚠ WARNING**

**Inexperienced mechanics or mechanics without the proper tools and equipment may not be able to properly perform the services described in this manual. Improper repair may result in injury to the mechanic and may render the motorcycle unsafe for the rider and passenger.**

## SUZUKI MOTOR CORPORATION

© COPYRIGHT SUZUKI MOTOR CORPORATION 2006

Sample of manual. Download All 522 pages at:

<https://www.arenairmanual.com/downloads/2005-2007-suzuki-gsx-r750-motorcycle-service-repair-workshop-manual/>

## GROUP INDEX

<b>GENERAL INFORMATION</b>	<b>1</b>
<b>PERIODIC MAINTENANCE</b>	<b>2</b>
<b>ENGINE</b>	<b>3</b>
<b>FI SYSTEM DIAGNOSIS</b>	<b>4</b>
<b>FUEL SYSTEM AND THROTTLE BODY</b>	<b>5</b>
<b>EXHAUST SYSTEM</b>	<b>6</b>
<b>COOLING AND LUBRICATION SYSTEM</b>	<b>7</b>
<b>CHASSIS</b>	<b>8</b>
<b>ELECTRICAL SYSTEM</b>	<b>9</b>
<b>SERVICING INFORMATION</b>	<b>10</b>
<b>EMISSION CONTROL INFORMATION</b>	<b>11</b>
<b>WIRING DIAGRAM</b>	<b>12</b>

## HOW TO USE THIS MANUAL TO LOCATE WHAT YOU ARE LOOKING FOR:

1. The text of this manual is divided into sections.
2. The section titles are listed in the GROUP INDEX.
3. Holding the manual as shown at the right will allow you to find the first page of the section easily.
4. The contents are listed on the first page of each section to help you find the item and page you need.

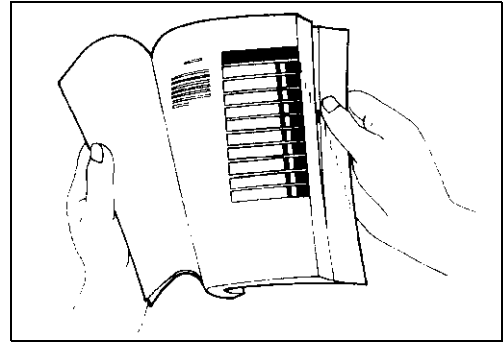

## COMPONENT PARTS AND WORK TO BE DONE

Under the name of each system or unit, is its exploded view. Work instructions and other service information such as the tightening torque, lubricating points and locking agent points, are provided.

Example: Front wheel

①	Brake disc
②	Collar
③	Dust seal
④	Bearing
⑤	Spacer
⑥	Front axle
⑦	Front wheel
A	Front axle bolt
B	Brake disc bolt





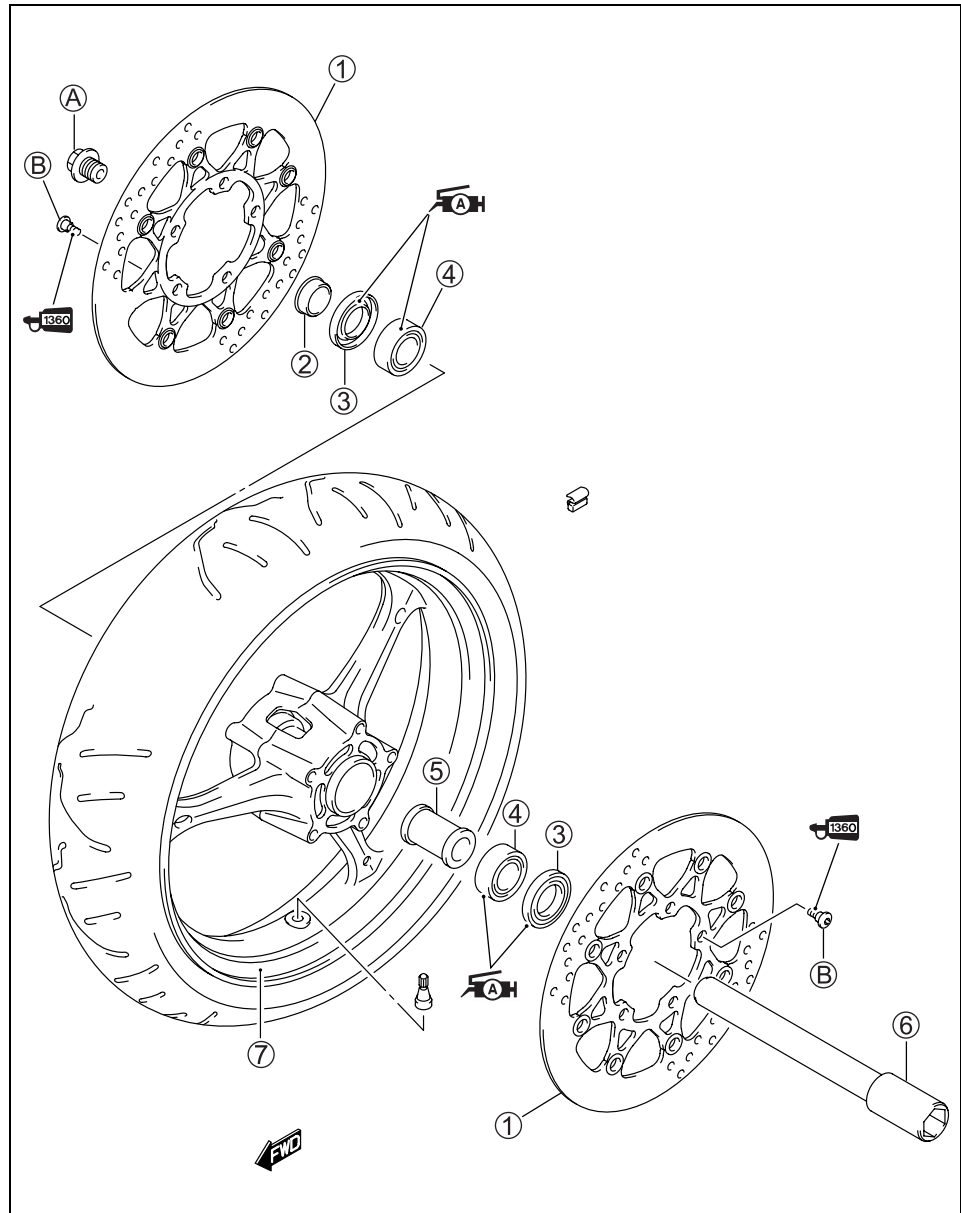



















ITEM	N·m	kgf·m	lb·ft
A	100	10.0	72.5
B	23	2.3	16.5



## SYMBOL

Listed in the table below are the symbols indicating instructions and other information necessary for servicing. The meaning of each symbol is also included in the table.

SYMBOL	DEFINITION	SYMBOL	DEFINITION
	Torque control required. Data beside it indicates specified torque.		Apply THREAD LOCK SUPER "1360". 99000-32130
	Apply oil. Use engine oil unless otherwise specified.		Use engine coolant. 99000-99032-11X (Except USA)
	Apply molybdenum oil solution. (Mixture of engine oil and SUZUKI MOLY PASTE in a ratio of 1:1)		Use fork oil. 99000-99001-SS5
	Apply SUZUKI SUPER GREASE "A" or equivalent grease. 99000-25010		Apply or use brake fluid.
	Apply SUZUKI SILICONE GREASE. 99000-25100		Measure in voltage range.
	Apply SUZUKI MOLY PASTE. 99000-25140		Measure in current range.
	Apply SUZUKI BOND "1215" or equivalent bond. 99000-31110		Measure in resistance range.
	Apply SUZUKI BOND "1207B". 99000-31140		Measure in diode test range.
	Apply THREAD LOCK SUPER "1303". 99000-32030		Measure in continuity test range.
	Apply THREAD LOCK SUPER "1322" or equivalent thread lock. 99000-32110		Use special tool.
	Apply THREAD LOCK "1342". 99000-32050		Indication of service data.

# ABBREVIATIONS USED IN THIS MANUAL

## A

ABDC	: After Bottom Dead Center
AC	: Alternating Current
ACL	: Air Cleaner, Air Cleaner Box
API	: American Petroleum Institute
ATDC	: After Top Dead Center
ATM Pressure	: Atmospheric Pressure
	: Atmospheric Pressure sensor (APS, AP Sensor)
A/F	: Air Fuel Mixture

## B

BBDC	: Before Bottom Dead Center
BTDC	: Before Top Dead Center
B+	: Battery Positive Voltage

## C

CKP Sensor	: Crankshaft Position Sensor (CKPS)
CKT	: Circuit
CLP Switch	: Clutch Lever Position Switch (Clutch Switch)
CMP Sensor	: Camshaft Position Sensor (CMPS)
CO	: Carbon Monoxide
CPU	: Central Processing Unit

## D

DC	: Direct Current
DMC	: Dealer Mode Coupler
DOHC	: Double Over Head Camshaft
DRL	: Daytime Running Light
DTC	: Diagnostic Trouble Code

## E

ECM	: Engine Control Module
	: Engine Control Unit (ECU) (FI Control Unit)
ECT Sensor	: Engine Coolant Temperature Sensor (ECTS), Water Temp. Sensor (WTS)
EVAP	: Evaporative Emission
EVAP Canister	: Evaporative Emission Canister (Canister)
EXC System	: Exhaust Control System (EXCS)
EXC Valve	: Exhaust Control Valve (EXCV)
EXCV Actuator	: Exhaust Control Valve Actuator (EXCVA)

## F

FI	: Fuel Injection, Fuel Injector
FP	: Fuel Pump
FPR	: Fuel Pressure Regulator
FP Relay	: Fuel Pump Relay

## G

GEN	: Generator
GND	: Ground
GP Switch	: Gear Position Switch

## H

HC	: Hydrocarbons
----	----------------

## I

IAP Sensor	: Intake Air Pressure Sensor (IAPS) (MAP Sensor)
IAT Sensor	: Intake Air Temperature Sensor (IATS)
IG	: Ignition

## L

LCD	: Liquid Crystal Display
LED	: Light Emitting Diode (Malfunction Indicator Lamp)
LH	: Left Hand

## **M**

MAL-Code : Malfunction Code  
(Diagnostic Code)  
Max : Maximum  
MIL : Malfunction Indicator Lamp  
(LED)  
Min : Minimum

## **N**

NOX : Nitrogen Oxides

## **O**

OHC : Over Head Camshaft  
OPS : Oil Pressure Switch

## **P**

PCV : Positive Crankcase  
Ventilation (Crankcase Breather)

## **R**

RH : Right Hand  
ROM : Read Only Memory

## **S**

SAE : Society of Automotive Engineers  
SDS : Suzuki Diagnosis System  
STC System : Secondary Throttle Control System  
(STCS)  
STP Sensor : Secondary Throttle Position Sensor  
(STPS)  
ST Valve : Secondary Throttle Valve (STV)  
STV Actuator : Secondary Throttle Valve Actuator  
(STVA)

## **T**

TO Sensor : Tip-Over Sensor (TOS)  
TP Sensor : Throttle Position Sensor (TPS)

## WIRE COLOR

B	: Black	G	: Green	P	: Pink
Bl	: Blue	Gr	: Gray	R	: Red
Br	: Brown	Lbl	: Light blue	W	: White
Dg	: Dark green	Lg	: Light green	Y	: Yellow
Dgr	: Dark gray	O	: Orange		

B/Bl	: Black with Blue tracer	B/Br	: Black with Brown tracer
B/G	: Black with Green tracer	B/Lg	: Black with Light green tracer
B/R	: Black with Red tracer	B/W	: Black with White tracer
B/Y	: Black with Yellow tracer	Bl/B	: Blue with Black tracer
Bl/G	: Blue with Green tracer	Bl/R	: Blue with Red tracer
Bl/W	: Blue with White tracer	Bl/Y	: Blue with Yellow tracer
Br/Y	: Brown with Yellow tracer	G/B	: Green with Black tracer
G/Bl	: Green with Blue tracer	G/R	: Green with Red tracer
G/W	: Green with White tracer	G/Y	: Green with Yellow tracer
Gr/B	: Gray with Black tracer	Gr/R	: Gray with Red tracer
Gr/W	: Gray with White tracer	Gr/Y	: Gray with Yellow tracer
Lg/Bl	: Light green with Blue tracer	Lg/G	: Light green with Green tracer
Lg/W	: Light green with White tracer	O/B	: Orange with Black tracer
O/Bl	: Orange with Blue tracer	O/G	: Orange with Green tracer
O/R	: Orange with Red tracer	O/W	: Orange with White tracer
O/Y	: Orange with Yellow tracer	P/B	: Pink with Black tracer
P/W	: Pink with White tracer	R/B	: Red with Black tracer
R/Bl	: Red with Blue tracer	R/Y	: Red with Yellow tracer
R/W	: Red with White tracer	W/B	: White with Black tracer
W/Bl	: White with Blue tracer	W/G	: White with Green tracer
W/R	: White with Red tracer	W/Y	: White with Yellow tracer
Y/B	: Yellow with Black tracer	Y/Bl	: Yellow with Blue tracer
Y/G	: Yellow with Green tracer	Y/R	: Yellow with Red tracer
Y/W	: Yellow with White tracer		

# GENERAL INFORMATION

1

## CONTENTS

<b>WARNING/CAUTION/NOTE</b> .....	<b>1- 2</b>
<b>GENERAL PRECAUTIONS</b> .....	<b>1- 2</b>
<b>SUZUKI GSX-R750K6 ('06-MODEL)</b> .....	<b>1- 4</b>
<b>SERIAL NUMBER LOCATION</b> .....	<b>1- 4</b>
<b>FUEL, OIL AND ENGINE COOLANT RECOMMENDATION</b> .....	<b>1- 5</b>
<b>FUEL (FOR USA AND CANADA)</b> .....	<b>1- 5</b>
<b>FUEL (FOR OTHER COUNTRIES)</b> .....	<b>1- 5</b>
<b>ENGINE OIL (FOR USA)</b> .....	<b>1- 5</b>
<b>ENGINE OIL (FOR OTHER COUNTRIES)</b> .....	<b>1- 5</b>
<b>BRAKE FLUID</b> .....	<b>1- 5</b>
<b>FRONT FORK OIL</b> .....	<b>1- 6</b>
<b>ENGINE COOLANT</b> .....	<b>1- 6</b>
<b>WATER FOR MIXING</b> .....	<b>1- 6</b>
<b>ANTI-FREEZE/ENGINE COOLANT</b> .....	<b>1- 6</b>
<b>LIQUID AMOUNT OF WATER/ENGINE COOLANT</b> .....	<b>1- 6</b>
<b>BREAK-IN PROCEDURES</b> .....	<b>1- 7</b>
<b>CYLINDER IDENTIFICATION</b> .....	<b>1- 7</b>
<b>INFORMATION LABELS</b> .....	<b>1- 8</b>
<b>SPECIFICATIONS</b> .....	<b>1- 9</b>
<b>DIMENSIONS AND DRY MASS</b> .....	<b>1- 9</b>
<b>ENGINE</b> .....	<b>1- 9</b>
<b>DRIVE TRAIN</b> .....	<b>1- 9</b>
<b>CHASSIS</b> .....	<b>1-10</b>
<b>ELECTRICAL</b> .....	<b>1-10</b>
<b>CAPACITIES</b> .....	<b>1-10</b>

## COUNTRY AND AREA CODES

The following codes stand for the applicable country(-ies) and area(-s).

CODE	COUNTRY or AREA	EFFECTIVE FRAME NO.
E-02	U.K.	JS1CF111100100001 –
E-19 (GSX-R750)	E.U.	JS1CF111100100001 –
E-19 (GSX-R750U2)	E.U.	JS1CF211100100001 –
E-24	Australia	JS1CF121300100001 –
E-03	U.S.A. (Except for California)	JS1GR7KA 62100001 –
E-28	Canada	JS1GR7KA 62100001 –
E-33	California (U.S.A.)	JS1GR7KA 62100001 –

## WARNING/CAUTION/NOTE

Please read this manual and follow its instructions carefully. To emphasize special information, the symbol and the words WARNING, CAUTION and NOTE have special meanings. Pay special attention to the messages highlighted by these signal words.

### **⚠ WARNING**

**Indicates a potential hazard that could result in death or injury.**

### **CAUTION**

**Indicates a potential hazard that could result in motorcycle damage.**

### *NOTE:*

*Indicates special information to make maintenance easier or instructions clearer.*

Please note, however, that the warnings and cautions contained in this manual cannot possibly cover all potential hazards relating to the servicing, or lack of servicing, of the motorcycle. In addition to the WARNINGS and CAUTIONS stated, you must use good judgement and basic mechanical safety principles. If you are unsure about how to perform a particular service operation, ask a more experienced mechanic for advice.

## GENERAL PRECAUTIONS

### **⚠ WARNING**

- \* Proper service and repair procedures are important for the safety of the service mechanic and the safety and reliability of the motorcycle.
  - \* When 2 or more persons work together, pay attention to the safety of each other.
  - \* When it is necessary to run the engine indoors, make sure that exhaust gas is forced outdoors.
  - \* When working with toxic or flammable materials, make sure that the area you work in is well-ventilated and that you follow all of the material manufacturer's instructions.
  - \* Never use gasoline as a cleaning solvent.
  - \* To avoid getting burned, do not touch the engine, engine oil, radiator and exhaust system until they have cooled.
- After servicing the fuel, oil, water, exhaust or brake systems, check all lines and fittings related to the system for leaks.

**CAUTION**

- \* If parts replacement is necessary, replace the parts with Suzuki Genuine Parts or their equivalent.
  - \* When removing parts that are to be reused, keep them arranged in an orderly manner so that they may be reinstalled in the proper order and orientation.
  - \* Be sure to use special tools when instructed.
  - \* Make sure that all parts used in reassembly are clean. Lubricate them when specified.
  - \* Use the specified lubricant, bond, or sealant.
  - \* When removing the battery, disconnect the negative cable first and then the positive cable.
  - \* When reconnecting the battery, connect the positive cable first and then the negative cable, and replace the terminal cover on the positive terminal.
  - \* When performing service to electrical parts, if the service procedures do not require use of battery power, disconnect the negative cable from the battery.
  - \* When tightening the cylinder head or case bolts and nuts, tighten the larger sizes first. Always tighten the bolts and nuts diagonally from the inside toward outside and to the specified tightening torque.
  - \* Whenever you remove oil seals, gaskets, packing, O-rings, locking washers, self-locking nuts, cotter pins, circlips and certain other parts as specified, be sure to replace them with new ones. Also, before installing these new parts, be sure to remove any left over material from the mating surfaces.
  - \* Never reuse a circlip. When installing a new circlip, take care not to expand the end gap larger than required to slip the circlip over the shaft. After installing a circlip, always ensure that it is completely seated in its groove and securely fitted.
  - \* Use a torque wrench to tighten fasteners to the specified torque. Wipe off grease and oil if a thread is smeared with them.
  - \* After reassembling, check parts for tightness and proper operation.
- 
- \* To protect the environment, do not unlawfully dispose of used motor oil, engine coolant and other fluids: batteries and tires.
  - \* To protect Earth's natural resources, properly dispose of used motorcycle and parts.

## SUZUKI GSX-R750K6 ('06-MODEL)

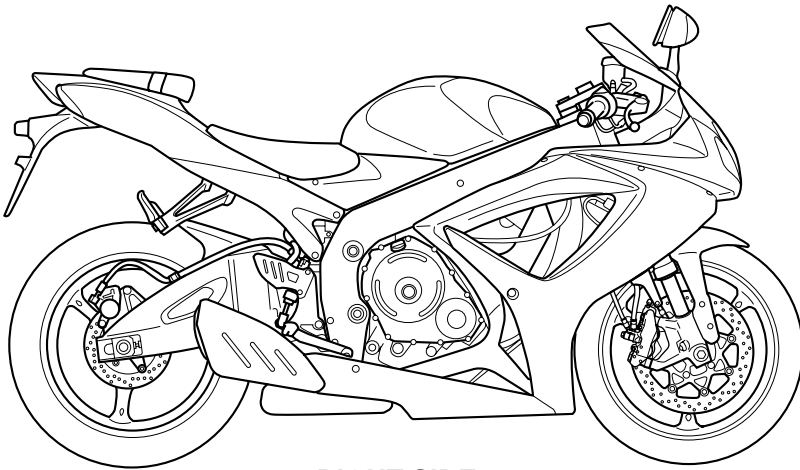

RIGHT SIDE

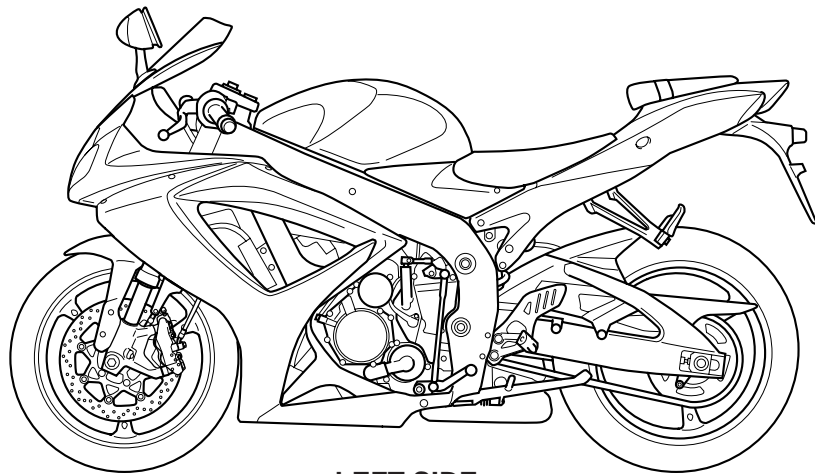

LEFT SIDE

- Difference between illustrations and actual motorcycle may exist depending on the markets.

## SERIAL NUMBER LOCATION

The frame serial number or V.I.N. (Vehicle Identification Number) ① is stamped on the right side of the steering head pipe. The engine serial number ② is located on the right side of the crankcase. These numbers are required especially for registering the machine and ordering spare parts.

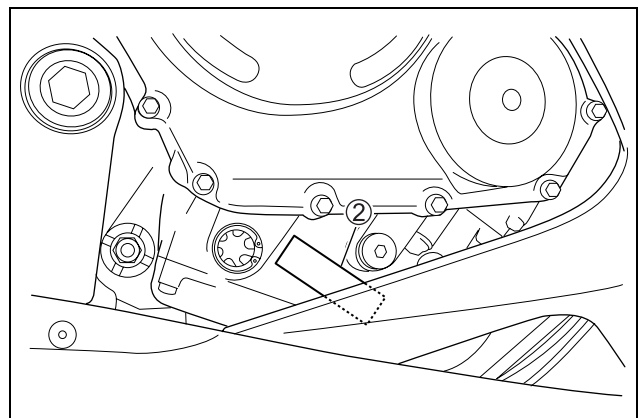
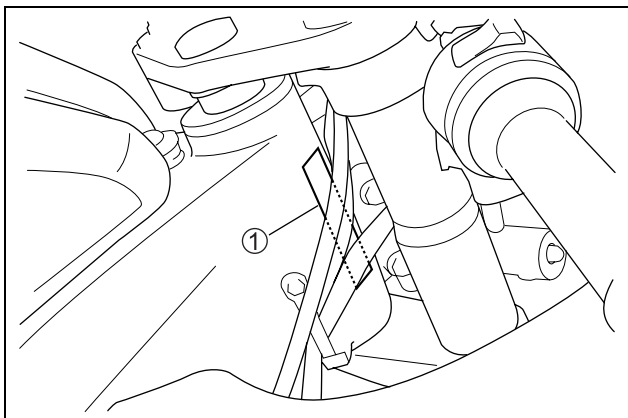

## FUEL, OIL AND ENGINE COOLANT RECOMMENDATION

### FUEL (FOR USA AND CANADA)

Use only unleaded gasoline of at least 90 pump octane (R/2 + M/2).

Gasoline containing MTBE (Methyl Tertiary Butyl Ether), less than 10% ethanol, or less than 5% methanol with appropriate cosolvents and corrosion inhibitor is permissible.

### FUEL (FOR OTHER COUNTRIES)

Gasoline used should be graded 95 octane (Research Method) or higher. Unleaded gasoline is recommended.

### ENGINE OIL (FOR USA)

Oil quality is a major contributor to your engine's performance and life. Always select good quality engine oil. Suzuki recommends the use of SUZUKI PERFORMANCE 4 MOTOR OIL or equivalent engine oil. Use of SF/SG or SH/SJ in API with MA in JASO.

Suzuki recommends the use of SAE 10W-40 engine oil. If SAE 10W-40 engine oil is not available, select an alternative according to the following chart.

### ENGINE OIL (FOR OTHER COUNTRIES)

Oil quality is a major contributor to your engine's performance and life. Always select good quality engine oil. Use of SF/SG or SH/SJ in API with MA in JASO.

Suzuki recommends the use of SAE 10W-40 engine oil. If SAE 10W-40 engine oil is not available, select an alternative according to the right chart.

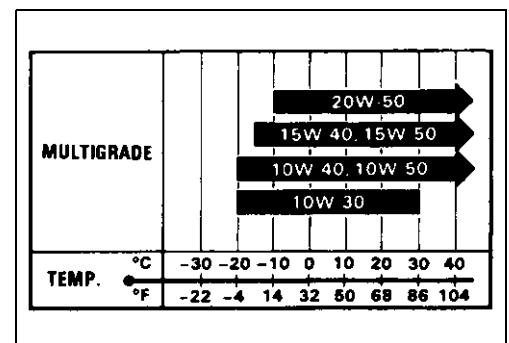

## BRAKE FLUID

Specification and classification: DOT 4

### ⚠ WARNING

Since the brake system of this motorcycle is filled with a glycol-based brake fluid by the manufacturer, do not use or mix different types of fluid such as silicone-based and petroleum-based fluid for refilling the system, otherwise serious damage will result.

Do not use any brake fluid taken from old or used or unsealed containers.

Never re-use brake fluid left over from a previous servicing, which has been stored for a long period.

## FRONT FORK OIL

Use fork oil SS-05 or an equivalent fork oil.

## ENGINE COOLANT

Use an anti-freeze/engine coolant compatible with an aluminum radiator, mixed with distilled water only.

## WATER FOR MIXING

Use distilled water only. Water other than distilled water can corrode and clog the aluminum radiator.

## ANTI-FREEZE/ENGINE COOLANT

The engine coolant performs as a corrosion and rust inhibitor as well as anti-freeze. Therefore, the engine coolant should be used at all times even though the atmospheric temperature in your area does not go down to freezing point.

Suzuki recommends the use of SUZUKI COOLANT anti-freeze/engine coolant. If this is not available, use an equivalent which is compatible with an aluminum radiator.

## LIQUID AMOUNT OF WATER/ENGINE COOLANT

**Solution capacity (total): Approx. 2 700 ml (2.9/2.4 US/Imp qt)**

For engine coolant mixture information, refer to cooling system section in page 7-2.

### CAUTION

**Mixing of anti-freeze/engine coolant should be limited to 60%. Mixing beyond it would reduce its efficiency. If the anti-freeze/engine coolant mixing ratio is below 50%, rust inhabiting performance is greatly reduced. Be sure to mix it above 50% even though the atmospheric temperature does not go down to the freezing point.**

## BREAK-IN PROCEDURES

During manufacture only the best possible materials are used and all machined parts are finished to a very high standard but it is still necessary to allow the moving parts to “BREAK-IN” before subjecting the engine to maximum stresses. The future performance and reliability of the engine depends on the care and restraint exercised during its early life. The general rules are as follows.

- Keep to these break-in engine speed limits:

**Initial 800 km ( 500 miles): Below 7 500 r/min**

**Up to 1 600 km (1 000 miles): Below 11 000 r/min**

**Over to 1 600 km (1 000 miles): Below 15 000 r/min**

- Upon reaching an odometer reading of 1 600 km (1 000 miles) you can subject the motorcycle to full throttle operation.

However, do not exceed 15 000 r/min at any time.

## CYLINDER IDENTIFICATION

The four cylinders of this engine are identified as No. 1, No. 2, No. 3 and No. 4 cylinder, as counted from left to right (as viewed by the rider on the seat.)



## INFORMATION LABELS

	GSX-R750	GSX-R750UF
① Noise label	A (For E-03, 24, 33)	
② Information label	A (For E-03, 28, 33)	
③ Vacuum hose routing label	A (For E-33)	
④ Fuel caution label	A (For E-02, 24)	
⑤ Fuel information label	A	A
⑥ Manual notice label	A (For E-03, 33)	
⑦ Screen label	A (Except E-19 )	
⑧ Screen label	A (For E-28)	A
⑨ Screen label	A (For E-19)	
⑩ Warning steering label	A (For E-03, 33)	
⑪ Warning steering label	A (Except E-03, 33)	A
⑫ Tire information label	A (For E-03, 33)	
⑬ Tire information label	A (Except E-03, 33)	A
⑭ General warning label	A (Except E-19, 28)	
⑮ General warning label		A
⑯ General warning label	A (For E-28)	
⑰ General warning label	A (For E-19)	
⑱ ICES Canada label	A (For E-28)	
⑲ I.D. plate	A (For E-02, 19, 24)	A
⑳ E-19 I.D. label		A
㉑ Safety plate	A (For E-03, 28, 33)	

A: Attached

\*1: Rear fender (front)

\*2: Chain case

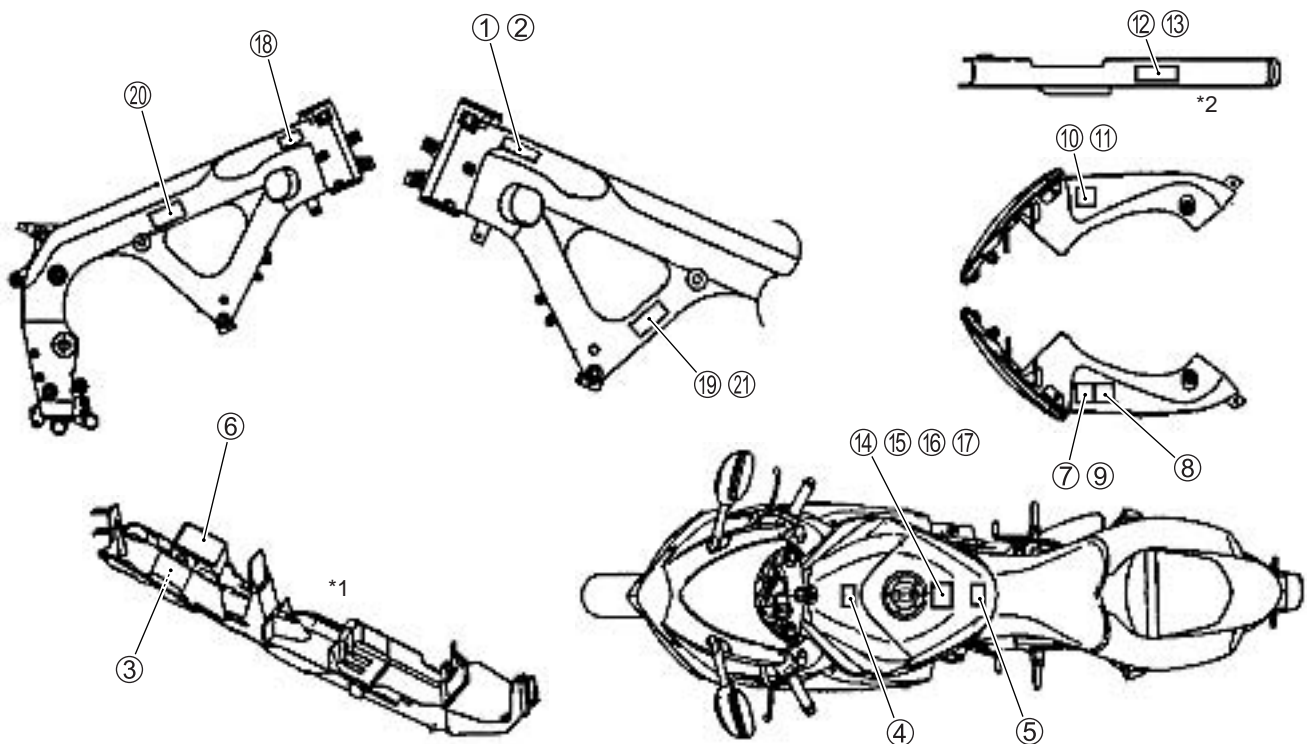

## SPECIFICATIONS

### DIMENSIONS AND DRY MASS

Overall length .....	2 040 mm (80.3 in)
Overall width .....	715 mm (28.1 in)
Overall height .....	1 125 mm (44.3 in)
Wheelbase .....	1 400 mm (55.1 in)
Ground clearance.....	130 mm (5.1 in)
Seat height .....	810 mm (31.9 in)
Dry mass .....	164 kg (361 lbs) .....E-33
	163 kg (359 lbs) .....Others

### ENGINE

Type .....	Four stroke, liquid-cooled, DOHC
Number of cylinders .....	4
Bore.....	70.0 mm (2.756 in)
Stroke .....	48.7 mm (1.917 in)
Displacement .....	750 cm <sup>3</sup> (45.8 cu. in)
Compression ratio .....	12.5 : 1
Fuel system .....	Fuel injection
Air cleaner .....	Paper element
Starter system .....	Electric
Lubrication system .....	Wet sump
Idle speed.....	1 200 ± 100 r/min

### DRIVE TRAIN

Clutch .....	Wet multi-plate type
Transmission .....	6-speed constant mesh
Gearshift pattern .....	1-down, 5-up
Primary reduction ratio .....	1.761 (74/42)
Gear ratios, Low .....	2.785 (39/14)
2nd.....	2.052 (39/19)
3rd.....	1.714 (36/21)
4th.....	1.500 (36/24)
5th.....	1.347 (31/23)
Top.....	1.208 (29/24)
Final reduction ratio.....	2.647 (45/17)
Drive chain .....	RK525ROZ5Y, 116 links

**CHASSIS**

Front suspension .....	Inverted telescopic, coil spring, oil damped
Rear suspension .....	Link type, coil spring, oil damped
Front fork stroke .....	120 mm (4.7 in)
Rear wheel travel .....	130 mm (5.1 in)
Steering angle .....	27°
Caster .....	23° 45'
Trail .....	97 mm (3.8 in)
Turning radius .....	3.4 m (11.2 ft)
Front brake .....	Disc brake, twin
Rear brake .....	Disc brake
Front tire size .....	120/70 ZR 17 M/C (58 W), tubeless
Rear tire size .....	180/55 ZR 17 M/C (73 W), tubeless

**ELECTRICAL**

Ignition type .....	Electronic ignition (Transistorized)
Ignition timing .....	8° B.T.D.C.at 1 200 r/min
Spark plug .....	NGK CR9E or DENSO U27ESR-N
Battery .....	12 V 36.0 kC (10 Ah)/10 HR
Generator .....	Three-phase A.C. generator
Main fuse .....	30 A
Fuse .....	10/10/15/15/10/10 A
Headlight .....	12 V 55 W (H7) + 12 V 65 W (H9)
Turn signal light .....	12 V 21 W
License plate light .....	12 V 5 W
Brake light/Taillight .....	LED
Position light .....	12 V 5 W × 2
Speedometer light .....	LED
Tachometer light .....	LED
Neutral indicator light .....	LED
High beam indicator light .....	LED
Turn signal indicator light .....	LED
Fuel level indicator light .....	LED
Oil pressure/Coolant temperature/FI warning light .....	LED
Engine RPM indicator light .....	LED
Immobilizer indicator light .....	LED .....E-02, 19, 24

**CAPACITIES**

Fuel tank, including reserve .....	15.5 L (4.1/3.4 US/Imp gal) ..... E-33
	16.5 L (4.4/3.6 US/Imp gal) ..... Others
Engine oil, oil change .....	2 200 ml (2.3/1.9 US/Imp qt)
with filter change .....	2 500 ml (2.6/2.2 US/Imp qt)
overhaul .....	2 900 ml (3.1/2.6 US/Imp qt)
Coolant .....	2.7 L (2.9/2.4 US/Imp qt)

These specifications are subject to change without notice.

# PERIODIC MAINTENANCE

## CONTENTS

<b>PERIODIC MAINTENANCE SCHEDULE</b> .....	2- 2
<b>PERIODIC MAINTENANCE CHART</b> .....	2- 2
<b>LUBRICATION POINTS</b> .....	2- 3
<b>MAINTENANCE AND TUNE-UP PROCEDURES</b> .....	2- 4
<b>AIR CLEANER</b> .....	2- 4
<b>SPARK PLUG</b> .....	2- 5
<b>VALVE CLEARANCE</b> .....	2- 7
<b>ENGINE OIL AND OIL FILTER</b> .....	2-12
<b>EXHAUST CONTROL VALVE</b> .....	2-13
<b>FUEL LINE</b> .....	2-14
<b>ENGINE IDLE SPEED</b> .....	2-14
<b>THROTTLE VALVE SYNCHRONIZATION</b> .....	2-15
<b>EVAPORATIVE EMISSION CONTROL SYSTEM (E-33 ONLY)</b> .....	2-15
<b>PAIR (AIR SUPPLY) SYSTEM</b> .....	2-15
<b>THROTTLE CABLE PLAY</b> .....	2-15
<b>CLUTCH</b> .....	2-16
<b>COOLING SYSTEM</b> .....	2-17
<b>DRIVE CHAIN</b> .....	2-20
<b>BRAKE</b> .....	2-23
<b>TIRES</b> .....	2-27
<b>STEERING</b> .....	2-27
<b>FRONT FORK</b> .....	2-28
<b>REAR SUSPENSION</b> .....	2-28
<b>EXHAUST PIPE BOLT AND NUT</b> .....	2-29
<b>CHASSIS BOLTS AND NUTS</b> .....	2-30
<b>COMPRESSION PRESSURE CHECK</b> .....	2-32
<b>COMPRESSION TEST PROCEDURE</b> .....	2-32
<b>OIL PRESSURE CHECK</b> .....	2-33
<b>SDS CHECK</b> .....	2-34

## PERIODIC MAINTENANCE SCHEDULE

The chart below lists the recommended intervals for all the required periodic service work necessary to keep the motorcycle operating at peak performance and economy. Mileages are expressed in terms of kilometers, miles and time for your convenience.

**IMPORTANT (For E-28):** The periodic maintenance intervals and service requirements have been established in accordance with EPA regulations. Following these instructions will ensure that the motorcycle will not exceed emission standards and it will also ensure the reliability and performance of the motorcycle.

**NOTE:**

*More frequent servicing may be required on motorcycles that are used under severe conditions.*

## PERIODIC MAINTENANCE CHART

Item	Interval	miles	600	4 000	7 500	11 000	14 500
		km	1 000	6 000	12 000	18 000	24 000
		months	2	12	24	36	48
Air cleaner element			—	I	I	R	I
Spark plugs			—	I	R	I	R
Valve clearance			—	—	—	—	I
Exhaust control valve			I	—	I	—	I
Engine oil			R	R	R	R	R
Engine oil filter			R	—	—	R	—
Fuel line			—	I	I	I	I
Idle speed			I	I	I	I	I
Throttle valve synchronization			I (E-33 only)	—	I	—	I
Evaporative emission control system (E-33 only)			—	—	I	—	I
PAIR (air supply) system			—	—	I	—	I
Throttle cable play			I	I	I	I	I
Clutch cable play			—	I	I	I	I
Radiator hoses			—	I	I	I	I
Engine coolant			Replace every 2 years.				
Drive chain			I	I	I	I	I
			Clean and lubricate every 1 000 km (600 miles).				
Brakes			I	I	I	I	I
Brake hoses			—	I	I	I	I
			Replace every 4 years.				
Brake fluid			—	I	I	I	I
			Replace every 2 years.				
Tires			—	I	I	I	I
Steering			I	—	I	—	I
Front forks			—	—	I	—	I
Rear suspension			—	—	I	—	I
Exhaust pipe bolts and muffler bolt and nut			T	—	T	—	T
Chassis bolts and nuts			T	T	T	T	T

**NOTE:**

*I = Inspect and clean, adjust, replace or lubricate as necessary; R = Replace; T = Tighten*

## LUBRICATION POINTS

Proper lubrication is important for smooth operation and long life of each working part of the motorcycle. Major lubrication points are indicated below.

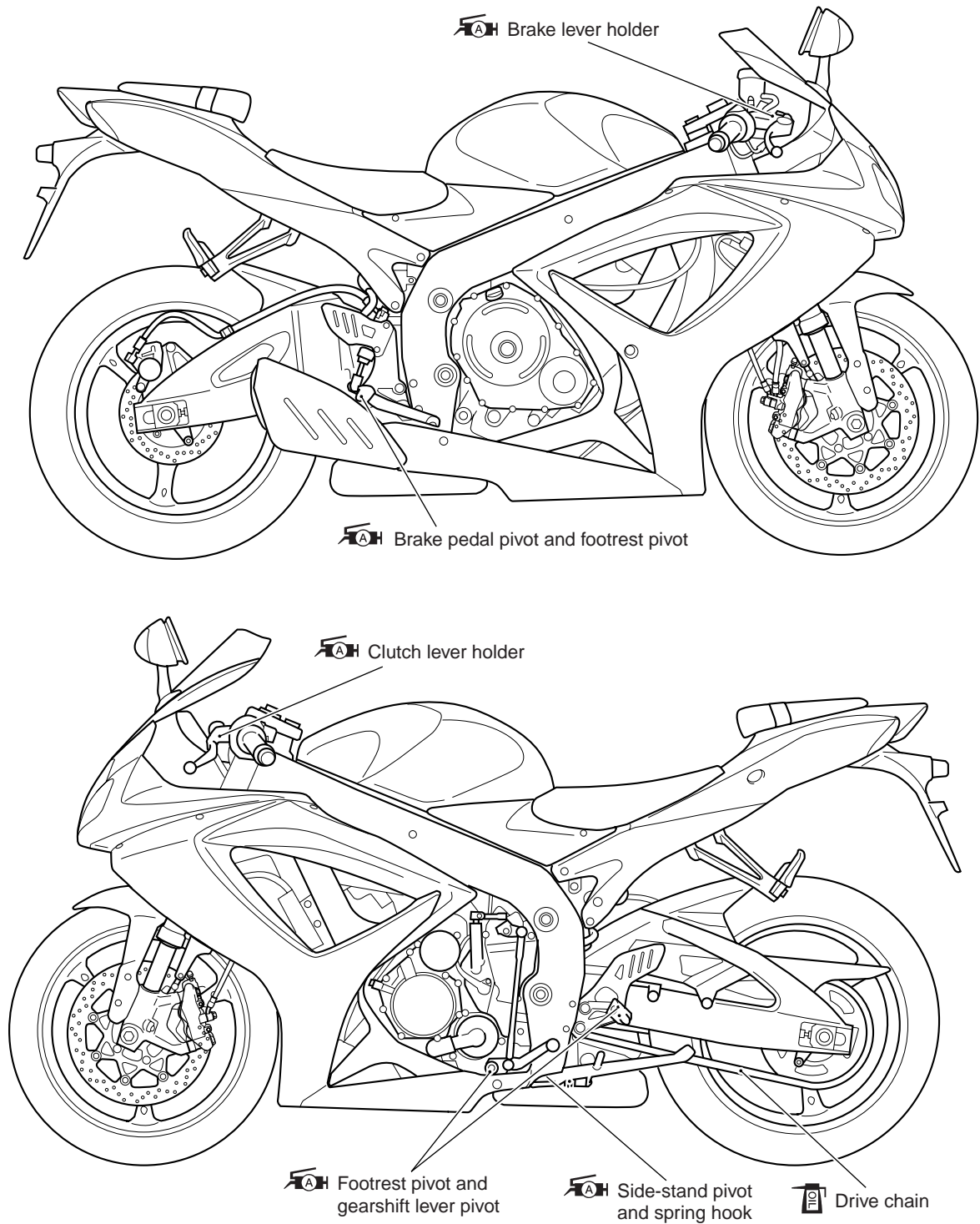

### NOTE:

- \* Before lubricating each part, clean off any rusty spots and wipe off any grease, oil, dirt or grime.
- \* Lubricate exposed parts which are subject to rust, with a rust preventative spray whenever the motorcycle has been operated under wet or rainy conditions.

## MAINTENANCE AND TUNE-UP PROCEDURES

This section describes the servicing procedures for each item of the Periodic Maintenance requirements.

### AIR CLEANER

**Inspect every 6 000 km (4 000 miles, 12 months).  
Replace every 18 000 km (11 000 miles, 36 months).**

- Remove the front seat. (☞ 8-7)
- Lift and support the fuel tank. (☞ 5-3)
- Remove the air cleaner element by removing the screws.
- Remove the air cleaner element.
- Inspect the air cleaner element for clogging.  
If the air cleaner element is clogged with dust, replace the air cleaner element with a new one.

#### CAUTION

**Do not blow the air cleaner element with compressed air.**

#### NOTE:

*If driving under dusty conditions, replace the air cleaner element more frequently. Make sure that the air cleaner is in good condition at all times. The life of the engine depends largely on this component.*

- Install a new air cleaner element in the reverse order of removal.
- Remove the drain plug from the air cleaner box to allow any water to drain out.



## SPARK PLUG

Inspect every 6 000 km (4 000 miles, 12 months).  
 Replace every 12 000 km (7 500 miles, 24 months).

### SPARK PLUG AND IGNITION COIL/PLUG CAP REMOVAL

- Remove the front seat. (☞ 8-7)
- Lift and support the fuel tank. (☞ 5-3)
- Remove the air cleaner box. (☞ 5-14)
- Disconnect all lead wire couplers from ignition coil/plug caps.

#### CAUTION

Disconnect the lead wire coupler before removing the ignition coil/plug cap to avoid lead wire coupler damage.

- Remove the ignition coils/plug caps.

#### CAUTION

\* Do not pry up the ignition coil/plug cap with a screw driver or a bar to avoid its damage.  
 \* Be careful not to drop the ignition coil/plug cap to prevent short/open circuit.

- Remove the spark plugs with a spark plug wrench.

### HEAT RANGE

- Check spark plug heat range by observing electrode color. If the electrode of the spark plug is wet appearing or dark color, replace the spark plug with hotter type one. If it is white or glazed appearing, replace the spark plug with colder type one.

	Hot type	Standard	Cold type
NGK	CR8E	CR9E	CR10E
ND	U24ESR-N	U27ESR-N	U31ESR-N

#### NOTE:

"R" type spark plug has a resistor built into at the center electrode to prevent radio noise.

### CARBON DEPOSITS

- Check carbon deposits on the spark plug.
- If carbon is deposited, remove it using a spark plug cleaner machine or carefully use a tool with a pointed end.

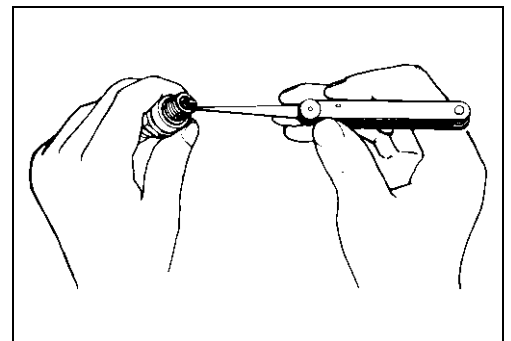
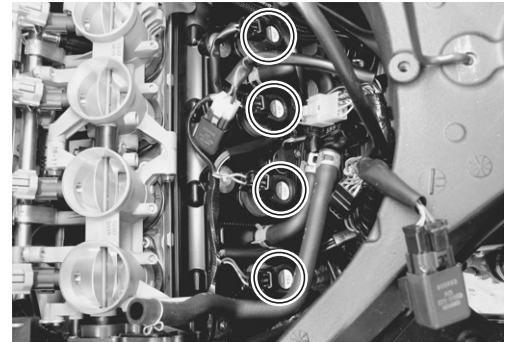

**SPARK PLUG GAP**

- Measure the spark plug gap with a thickness gauge.
- Adjust the spark plug gap if necessary.

**DATA** Spark plug gap:  
 Standard: 0.7 – 0.8 mm (0.028 – 0.031 in)

**TOOL** 09900-20803: Thickness gauge

**ELECTRODE'S CONDITION**

- Check the condition of the electrode.
- If it is extremely worn or burnt, replace the spark plug. Replace the spark plug if it has a broken insulator, damaged thread, etc.

**CAUTION**

Confirm the thread size and reach when replacing the plug. If the reach is too short, carbon will be deposited on the screw portion of the plug hole and engine damage may result.

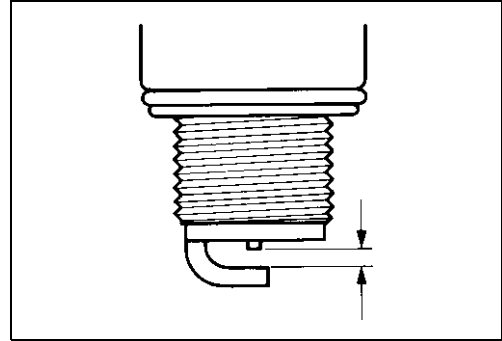

**SPARK PLUG AND IGNITION COIL/PLUG CAP INSTALLATION**

- Screw the spark plugs into the cylinder head with fingers, and then tighten them to the specified torque.

**Spark plug: 11 N·m (1.1 kgf·m, 8.0 lb-ft)**

**CAUTION**

Do not cross thread or over tighten the spark plug, or such an operation will damage the aluminum threads of the cylinder head.



- Install the ignition coils/plug caps and connect their lead wire couplers.

**CAUTION**

- \* Do not hit the ignition coil/plug cap with a plastic hammer when installing it.
- \* Place the ignition coil/spark plug cap so that the coupler does not touch the cylinder head cover.

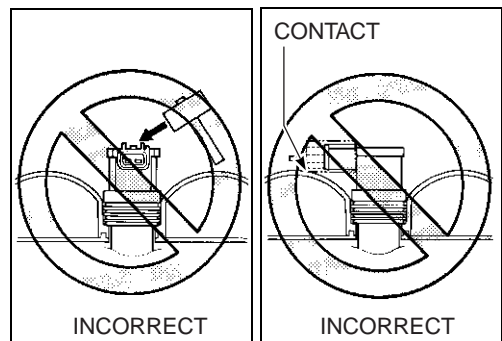
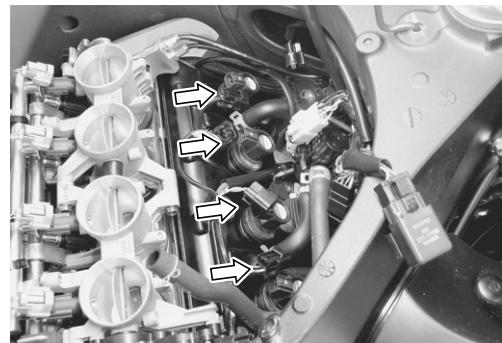

## VALVE CLEARANCE

**Inspect every 24 000 km (14 500 miles, 48 months).**

- Remove the right under cowling. (🔧 8-5)
  - Lift and support the fuel tank. (🔧 5-3)
  - Remove the air cleaner box. (🔧 5-14)
  - Disconnect the CMP sensor coupler ①.
  - Remove the PAIR control solenoid valve ②.
  - Remove the spark plugs. (🔧 2-5)
- 
- Loosen the throttle body clamp screws at the intake pipe side.
  - Move the throttle body assembly.
  - Move the radiator forward. (🔧 6-10)
  - Remove the regulator/rectifier and horn. (🔧 3-6)
  - Remove the cylinder head cover. (🔧 3-14)

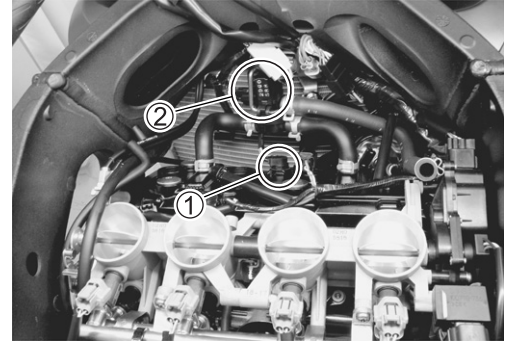

The valve clearance specification is different for intake and exhaust valves. Valve clearance must be checked and adjusted, 1) at the time of periodic inspection, 2) when the valve mechanism is serviced, and 3) when the camshafts are removed for servicing.

### **DATA** Valve clearance (when cold):

**Standard: IN. : 0.08 – 0.18 mm (0.003 – 0.007 in)**

**EX. : 0.18 – 0.28 mm (0.007 – 0.011 in)**

### NOTE:

- \* The cam must be at positions, (A) or (B), when checking or adjusting the valve clearance. Clearance readings should not be taken with the cam in any other position than these two positions.
- \* The clearance specification is for COLD state.
- \* To turn the crankshaft for clearance checking, be sure to use a wrench, and rotate in the normal running direction. All spark plugs should be removed.

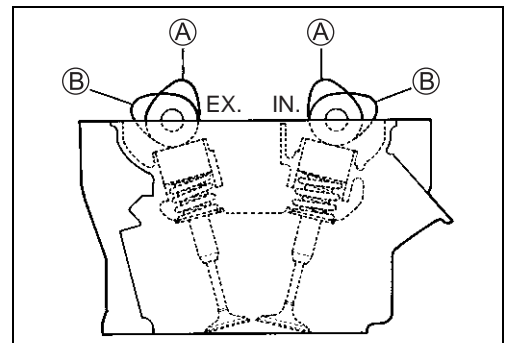

- Remove the valve timing inspection cap ①.

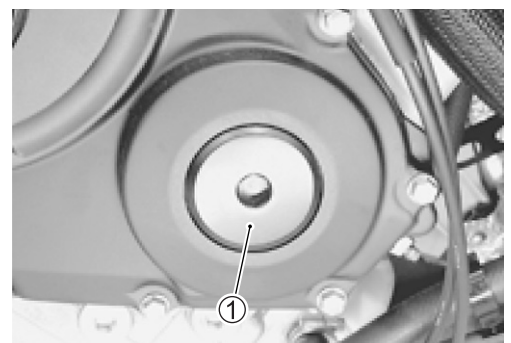

- Turn the crankshaft to bring the line (A) on the CKP sensor rotor to the rib (B) behind the clutch cover and also to bring the notches (A) on the left ends of both camshafts (Ex. and In.) to the positions as shown.

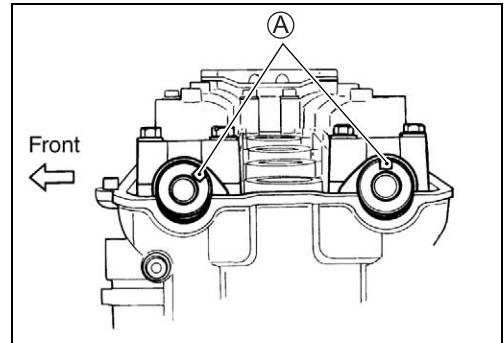
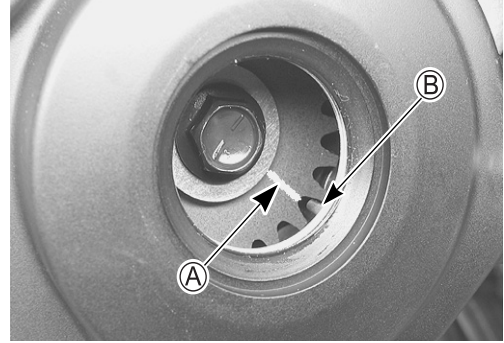

- In this condition, read the valve clearance at the valves (B) (In. and Ex. of No. 4 cylinder, Ex. of No. 3 and In. of No. 2).
- If the clearance is out of specification, adjust the clearance. (☞ 2-9)

**TOOL** 09900-20803: Thickness gauge

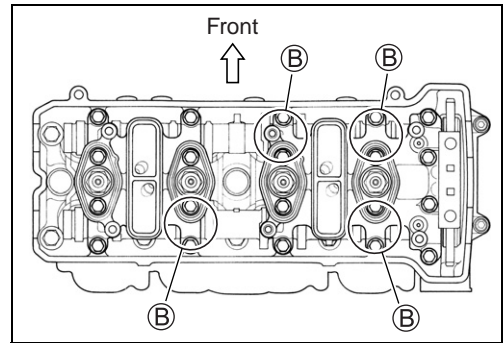

- Turn the crankshaft 360 degrees (one rotation) to bring the line on the CKP sensor rotor to the index mark of valve timing inspection hole and also to bring the notches (A) to the position as shown.
- Read the clearance at the rest of the valves (C) and adjust the clearance if necessary. (☞ 2-9)

Cam position	Notch (A) position	
	Exhaust Camshaft	Intake Camshaft
(B)	← Front	← Front
(C)	← Front	← Front

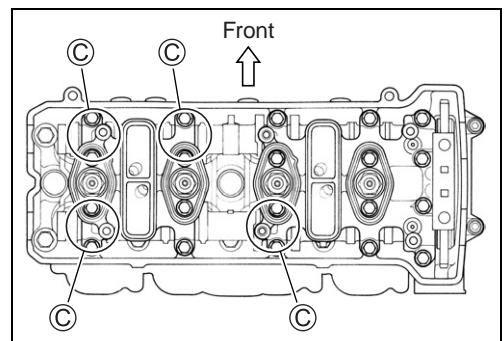
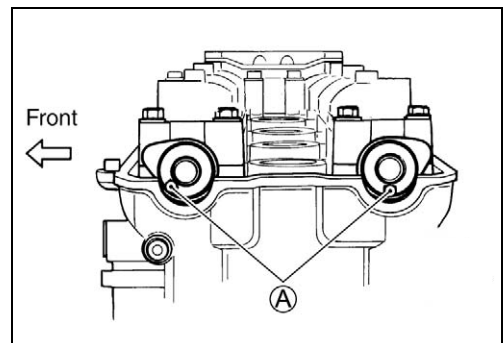

## VALVE CLEARANCE ADJUSTMENT

The clearance is adjusted by replacing the existing tappet shim by a thicker or thinner shim.

- Remove the intake or exhaust camshafts. (☞ 3-14)
- Remove the tappet and shim by fingers or magnetic hand.
- Check the figures printed on the shim. These figures indicate the thickness of the shim, as illustrated.
- Select a replacement shim that will provide a clearance within the specified range. For the purpose of this adjustment, a total of 21 sizes of tappet shim are available ranging from 1.20 to 2.20 mm in steps of 0.05 mm. Fit the selected shim to the valve stem end, with numbers toward tappet. Be sure to check shim size with micrometer to ensure its size. Refer to the tappet shim selection table (☞ 2-10 and -11) for details.

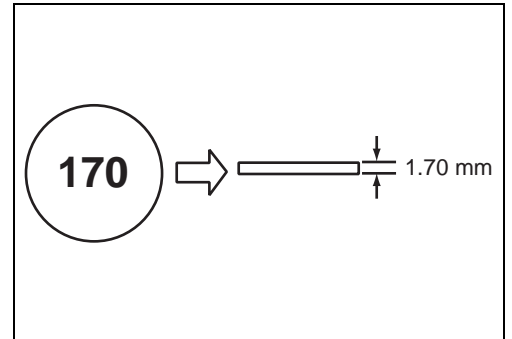

### NOTE:

- \* Be sure to apply engine oil to tappet shim top and bottom faces.
- \* When seating the tappet shim, be sure the figure printed surface faces the tappet.

### NOTE:

Reinstall the camshafts in the specified manner. (☞ 3-92)

- After replacing the tappet shim and camshafts, rotate the engine so that the tappet is depressed fully. This will squeeze out oil trapped between the shim and the tappet that could cause an incorrect measurement. Then check the clearance again to confirm that it is within the specified range.
- After finishing the valve clearance adjustment, reinstall the following items.
  - \* Cylinder head cover (☞ 3-97)
  - \* Spark plug and plug cap (☞ 2-6)
  - \* Throttle body assembly (☞ 5-21)
  - \* Valve timing inspection plug (☞ 3-97)
  - \* PAIR control solenoid valve (☞ 11-7)

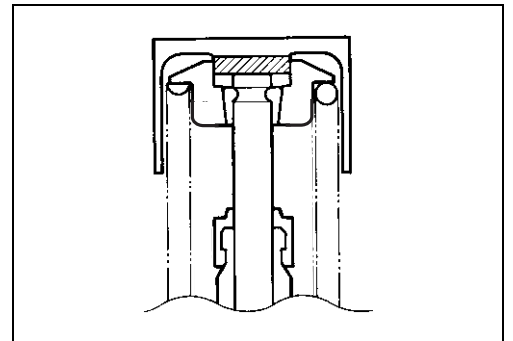

(INTAKE SIDE)

TAPPET SHIM SELECTION TABLE [INTAKE]  
TAPPET SHIM NO. (12892-05C00-XXX)

TAPPET SHIM SET (12800-05830)

MEASURED VALVE CLEARANCE (mm)	SUFFIX NO.	120	125	130	135	140	145	150	155	160	165	170	175	180	185	190	195	200	205	210	215	220	SPECIFIED CLEARANCE/NO ADJUSTMENT REQUIRED	
																							PRESENT SHIM SIZE (mm)	1.20
0.00 - 0.04		1.20	1.25	1.30	1.35	1.40	1.45	1.50	1.55	1.60	1.65	1.70	1.75	1.80	1.85	1.90	1.95	2.00	2.05	2.10	2.15	2.20		
0.05 - 0.09		1.20	1.25	1.30	1.35	1.40	1.45	1.50	1.55	1.60	1.65	1.70	1.75	1.80	1.85	1.90	1.95	2.00	2.05	2.10	2.15	2.20		
0.10 - 0.20		1.20	1.25	1.30	1.35	1.40	1.45	1.50	1.55	1.60	1.65	1.70	1.75	1.80	1.85	1.90	1.95	2.00	2.05	2.10	2.15	2.20		
0.21 - 0.25		1.30	1.35	1.40	1.45	1.50	1.55	1.60	1.65	1.70	1.75	1.80	1.85	1.90	1.95	2.00	2.05	2.10	2.15	2.20				
0.26 - 0.30		1.35	1.40	1.45	1.50	1.55	1.60	1.65	1.70	1.75	1.80	1.85	1.90	1.95	2.00	2.05	2.10	2.15	2.20					
0.31 - 0.35		1.40	1.45	1.50	1.55	1.60	1.65	1.70	1.75	1.80	1.85	1.90	1.95	2.00	2.05	2.10	2.15	2.20						
0.36 - 0.40		1.45	1.50	1.55	1.60	1.65	1.70	1.75	1.80	1.85	1.90	1.95	2.00	2.05	2.10	2.15	2.20							
0.41 - 0.45		1.50	1.55	1.60	1.65	1.70	1.75	1.80	1.85	1.90	1.95	2.00	2.05	2.10	2.15	2.20								
0.46 - 0.50		1.55	1.60	1.65	1.70	1.75	1.80	1.85	1.90	1.95	2.00	2.05	2.10	2.15	2.20									
0.51 - 0.55		1.60	1.65	1.70	1.75	1.80	1.85	1.90	1.95	2.00	2.05	2.10	2.15	2.20										
0.56 - 0.60		1.65	1.70	1.75	1.80	1.85	1.90	1.95	2.00	2.05	2.10	2.15	2.20											
0.61 - 0.65		1.70	1.75	1.80	1.85	1.90	1.95	2.00	2.05	2.10	2.15	2.20												
0.66 - 0.70		1.75	1.80	1.85	1.90	1.95	2.00	2.05	2.10	2.15	2.20													
0.71 - 0.75		1.80	1.85	1.90	1.95	2.00	2.05	2.10	2.15	2.20														
0.76 - 0.80		1.85	1.90	1.95	2.00	2.05	2.10	2.15	2.20															
0.81 - 0.85		1.90	1.95	2.00	2.05	2.10	2.15	2.20																
0.86 - 0.90		1.95	2.00	2.05	2.10	2.15	2.20																	
0.91 - 0.95		2.00	2.05	2.10	2.15	2.20																		
0.96 - 1.00		2.05	2.10	2.15	2.20																			
1.01 - 1.05		2.10	2.15	2.20																				
1.06 - 1.10		2.15	2.20																					
1.11 - 1.15		2.20																						

HOW TO USE THIS CHART:

- I. Measure valve clearance. "ENGINE IS COLD"
  - II. Measure present shim size.
  - III. Match clearance in vertical column with present shim size in horizontal column.
- EXAMPLE
- Valve clearance is 0.23 mm
  - Present shim size 1.70 mm
  - Shim size to be used 1.80 mm

(EXHAUST SIDE)

TAPPET SHIM SELECTION TABLE [EXHAUST]  
TAPPET SHIM NO. (12892-05C00-XXX)

TAPPET SHIM SET (12800-05830)

MEASURED VALVE CLEARANCE (mm)	SUFFIX NO.	SPECIFIED CLEARANCE/NO ADJUSTMENT REQUIRED																				
		120	125	130	135	140	145	150	155	160	165	170	175	180	185	190	195	200	205	210	215	220
0.05 - 0.09	1.20	1.25	1.30	1.35	1.40	1.45	1.50	1.55	1.60	1.65	1.70	1.75	1.80	1.85	1.90	1.95	2.00	2.05	2.10	2.15	2.20	2.20
0.10 - 0.14	1.20	1.25	1.30	1.35	1.40	1.45	1.50	1.55	1.60	1.65	1.70	1.75	1.80	1.85	1.90	1.95	2.00	2.05	2.10	2.15	2.20	2.20
0.15 - 0.19	1.20	1.25	1.30	1.35	1.40	1.45	1.50	1.55	1.60	1.65	1.70	1.75	1.80	1.85	1.90	1.95	2.00	2.05	2.10	2.15	2.20	2.20
0.20 - 0.30	1.30	1.35	1.40	1.45	1.50	1.55	1.60	1.65	1.70	1.75	1.80	1.85	1.90	1.95	2.00	2.05	2.10	2.15	2.20	2.20	2.20	2.20
0.31 - 0.35	1.35	1.40	1.45	1.50	1.55	1.60	1.65	1.70	1.75	1.80	1.85	1.90	1.95	2.00	2.05	2.10	2.15	2.20	2.20	2.20	2.20	2.20
0.36 - 0.40	1.40	1.45	1.50	1.55	1.60	1.65	1.70	1.75	1.80	1.85	1.90	1.95	2.00	2.05	2.10	2.15	2.20	2.20	2.20	2.20	2.20	2.20
0.41 - 0.45	1.45	1.50	1.55	1.60	1.65	1.70	1.75	1.80	1.85	1.90	1.95	2.00	2.05	2.10	2.15	2.20	2.20	2.20	2.20	2.20	2.20	2.20
0.46 - 0.50	1.45	1.50	1.55	1.60	1.65	1.70	1.75	1.80	1.85	1.90	1.95	2.00	2.05	2.10	2.15	2.20	2.20	2.20	2.20	2.20	2.20	2.20
0.51 - 0.55	1.50	1.55	1.60	1.65	1.70	1.75	1.80	1.85	1.90	1.95	2.00	2.05	2.10	2.15	2.20	2.20	2.20	2.20	2.20	2.20	2.20	2.20
0.56 - 0.60	1.55	1.60	1.65	1.70	1.75	1.80	1.85	1.90	1.95	2.00	2.05	2.10	2.15	2.20	2.20	2.20	2.20	2.20	2.20	2.20	2.20	2.20
0.61 - 0.65	1.60	1.65	1.70	1.75	1.80	1.85	1.90	1.95	2.00	2.05	2.10	2.15	2.20	2.20	2.20	2.20	2.20	2.20	2.20	2.20	2.20	2.20
0.66 - 0.70	1.65	1.70	1.75	1.80	1.85	1.90	1.95	2.00	2.05	2.10	2.15	2.20	2.20	2.20	2.20	2.20	2.20	2.20	2.20	2.20	2.20	2.20
0.71 - 0.75	1.70	1.75	1.80	1.85	1.90	1.95	2.00	2.05	2.10	2.15	2.20	2.20	2.20	2.20	2.20	2.20	2.20	2.20	2.20	2.20	2.20	2.20
0.76 - 0.80	1.75	1.80	1.85	1.90	1.95	2.00	2.05	2.10	2.15	2.20	2.20	2.20	2.20	2.20	2.20	2.20	2.20	2.20	2.20	2.20	2.20	2.20
0.81 - 0.85	1.80	1.85	1.90	1.95	2.00	2.05	2.10	2.15	2.20	2.20	2.20	2.20	2.20	2.20	2.20	2.20	2.20	2.20	2.20	2.20	2.20	2.20
0.86 - 0.90	1.85	1.90	1.95	2.00	2.05	2.10	2.15	2.20	2.20	2.20	2.20	2.20	2.20	2.20	2.20	2.20	2.20	2.20	2.20	2.20	2.20	2.20
0.91 - 0.95	1.90	1.95	2.00	2.05	2.10	2.15	2.20	2.20	2.20	2.20	2.20	2.20	2.20	2.20	2.20	2.20	2.20	2.20	2.20	2.20	2.20	2.20
0.96 - 1.00	1.95	2.00	2.05	2.10	2.15	2.20	2.20	2.20	2.20	2.20	2.20	2.20	2.20	2.20	2.20	2.20	2.20	2.20	2.20	2.20	2.20	2.20
1.01 - 1.05	2.00	2.05	2.10	2.15	2.20	2.20	2.20	2.20	2.20	2.20	2.20	2.20	2.20	2.20	2.20	2.20	2.20	2.20	2.20	2.20	2.20	2.20
1.06 - 1.10	2.05	2.10	2.15	2.20	2.20	2.20	2.20	2.20	2.20	2.20	2.20	2.20	2.20	2.20	2.20	2.20	2.20	2.20	2.20	2.20	2.20	2.20
1.11 - 1.15	2.10	2.15	2.20	2.20	2.20	2.20	2.20	2.20	2.20	2.20	2.20	2.20	2.20	2.20	2.20	2.20	2.20	2.20	2.20	2.20	2.20	2.20
1.16 - 1.20	2.15	2.20	2.20	2.20	2.20	2.20	2.20	2.20	2.20	2.20	2.20	2.20	2.20	2.20	2.20	2.20	2.20	2.20	2.20	2.20	2.20	2.20
1.21 - 1.25	2.20	2.20	2.20	2.20	2.20	2.20	2.20	2.20	2.20	2.20	2.20	2.20	2.20	2.20	2.20	2.20	2.20	2.20	2.20	2.20	2.20	2.20

HOW TO USE THIS CHART:

- I. Measure valve clearance. "ENGINE IS COLD"
- II. Measure present shim size.
- III. Match clearance in vertical column with present shim size in horizontal column.

EXAMPLE

Valve clearance is 0.33 mm  
Present shim size 1.70 mm  
Shim size to be used 1.80 mm

## ENGINE OIL AND OIL FILTER

### (ENGINE OIL)

Replace initially at 1 000 km (600 miles, 2 months) and every 6 000 km (4 000 miles, 12 months) thereafter.

### (OIL FILTER)

Replace initially at 1 000 km (600 miles, 2 months) and every 18 000 km (11 000 miles, 36 months) thereafter.



### ENGINE OIL REPLACEMENT

- Remove the under cowlings. (☞ 8-5)
- Keep the motorcycle upright.
- Place an oil pan below the engine, and drain oil by removing the oil drain plug ① and filler cap ②.
- Tighten the drain plug ① to the specified torque, and pour fresh oil through the oil filler. The engine will hold about 2.2 L (2.3/1.9 US/Imp qt) of oil. Use of SF/SG or SH/SJ in API with MA in JASO.

 **Oil drain plug: 23 N·m (2.3 kgf·m, 16.5 lb-ft)**



- Start up the engine and allow it to run for several minutes at idling speed.
- Turn off the engine and wait about three minutes, then check the oil level through the inspection window. If the level is below mark “L”, add oil to “F” level. If the level is above mark “F”, drain oil to “F” level.

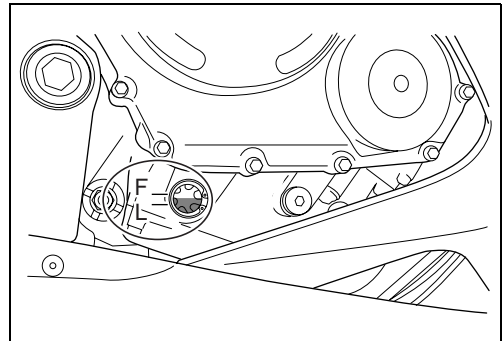

**OIL FILTER REPLACEMENT**

- Drain the engine oil as described in the engine oil replacement procedure.
- Remove the oil filter ① with the special tool.

**TOOL 09915-40610: Oil filter wrench**

- Apply engine oil lightly to the gasket of the new oil filter before installation.

- Install the new oil filter. Turn it by hand until you feel that the oil filter gasket contacts the oil filter mounting surface. Then, tighten the oil filter two full turns (or to specified torque) with the special tool.

**NOTE:**

To properly tighten the oil filter, use the special tool. Never tighten the oil filter by hand.

**Oil filter: 20 N·m (2.0 kgf·m, 14.5 lb·ft)**

- Add new engine oil and check the oil level is as described in the engine oil replacement procedure.

**DATA NECESSARY AMOUNT OF ENGINE OIL:**

Oil change	: 2.2 L (2.3/1.9 US/Imp qt)
Oil and filter change	: 2.5 L (2.6/2.2 US/Imp qt)
Engine overhaul	: 2.9 L (3.1/2.6 US/Imp qt)

**CAUTION**

**ONLY USE A GENUINE SUZUKI MOTORCYCLE OIL FILTER.** Other manufacturer's oil filters may differ in thread specifications (thread diameter and pitch), filtering performance and durability which may lead to engine damage or oil leaks. Also, do not use a genuine Suzuki automobile oil filter on this motorcycle.

**EXHAUST CONTROL VALVE**

**Inspect initially at 1 000 km (600 miles, 2 months) and every 12 000 km (7 500 miles, 24 months) thereafter.**

Exhaust control valve actuator is installed in the right-hand side in tail cowl.

Check the exhaust control valve actuator ① for its movement when the ignition switch is turned ON. If the exhaust valve actuator does not move, check exhaust valve actuator electrical circuit and exhaust valve carbon sticking. Check the exhaust control cable play. (6-14)

