

FOREWORD

This manual contains an introductory description on the SUZUKI GSX-R1000 and procedures for its inspection/service and overhaul of its main components.

Other information considered as generally known is not included.

Read the GENERAL INFORMATION section to familiarize yourself with the motorcycle and its maintenance. Use this section as well as other sections to use as a guide for proper inspection and service. This manual will help you know the motorcycle better so that you can assure your customers of fast and reliable service.

* This manual has been prepared on the basis of the latest specifications at the time of publication. If modifications have been made since then, differences may exist between the content of this manual and the actual motorcycle.

* Illustrations in this manual are used to show the basic principles of operation and work procedures. They may not represent the actual motorcycle exactly in detail.

* This manual is written for persons who have enough knowledge, skills and tools, including special tools, for servicing SUZUKI motorcycles. If you do not have the proper knowledge and tools, ask your authorized SUZUKI motorcycle dealer to help you.

▲ WARNING

Inexperienced mechanics or mechanics without the proper tools and equipment may not be able to properly perform the services described in this manual.

Improper repair may result in injury to the mechanic and may render the motorcycle unsafe for the rider and passenger.

SUZUKI MOTOR CORPORATION

© COPYRIGHT SUZUKI MOTOR CORPORATION 2003

Sample of manual. Download All 460 pages at:

<https://www.arepairmanual.com/downloads/2003-2004-suzuki-gsx-r1000-motorcycle-service-repair-workshop-manual/>

GROUP INDEX

GENERAL INFORMATION	1
PERIODIC MAINTENANCE	2
ENGINE	3
FI SYSTEM DIAGNOSIS	4
FUEL SYSTEM AND THROTTLE BODY	5
EXHAUST SYSTEM	6
COOLING AND LUBRICATION SYSTEM	7
CHASSIS	8
ELECTRICAL SYSTEM	9
SERVICING INFORMATION	10
EMISSION CONTROL INFORMATION	11
WIRING DIAGRAM	12

HOW TO USE THIS MANUAL TO LOCATE WHAT YOU ARE LOOKING FOR:

1. The text of this manual is divided into sections.
2. The section titles are listed in the GROUP INDEX.
3. Holding the manual as shown at the right will allow you to find the first page of the section easily.
4. The contents are listed on the first page of each section to help you find the item and page you need.

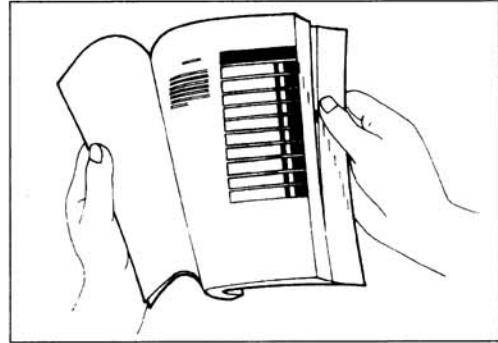

COMPONENT PARTS AND WORK TO BE DONE

Under the name of each system or unit, is its exploded view. Work instructions and other service information such as the tightening torque, lubricating points and locking agent points, are provided.

Example: Front wheel

















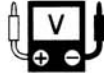
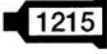
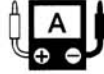

- ① Brake disc
- ② Dust seal
- ③ Bearing
- ④ Spacer
- ⑤ Spacer nut
- ⑥ Front wheel

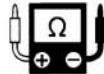
- A Front axle
- B Brake disc bolt (Front)

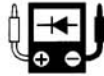
ITEM	N·m	kgf·m	lb·ft
A	100	10.0	72.5
B	23	2.3	16.5

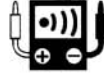
SYMBOL

Listed in the table below are the symbols indicating instructions and other information necessary for servicing. The meaning of each symbol is also included in the table.

SYMBOL	DEFINITION	SYMBOL	DEFINITION
	Torque control required. Data beside it indicates specified torque.		Apply THREAD LOCK SUPER "1360". 99000-32130
	Apply oil. Use engine oil unless otherwise specified.		Use engine coolant.
	Apply molybdenum oil solution. (Mixture of engine oil and SUZUKI MOLY PASTE in a ratio of 1:1)		Use fork oil. 99000-99044-L01
	Apply SUZUKI SUPER GREASE "A". 99000-25010 (Others) 99000-25030 (USA)		Apply or use brake fluid.
	Apply SUZUKI MOLY PASTE. 99000-25140		Measure in voltage range.
	Apply SUZUKI BOND "1215". 99000-31110 (Except USA)		Measure in current range.
	Apply SUZUKI BOND "1207B". 99104-31140 (USA)		Measure in resistance range.
	Apply SUZUKI BOND "1207B". 99000-31140 (Except USA)		Measure in diode test range.
	Apply THREAD LOCK SUPER "1303". 99000-32030		Measure in continuity test range.
	Apply THREAD LOCK SUPER "1322". 99000-32110 (Except USA)		Use special tool.
	Apply THREAD LOCK "1342". 99000-32050 (USA)		Indication of service data.

ABBREVIATIONS USED IN THIS MANUAL

A

ABDC : After Bottom Dead Center
AC : Alternating Current
ACL : Air Cleaner, Air Cleaner Box
API : American Petroleum Institute
ATDC : After Top Dead Center
ATM Pressure: Atmospheric Pressure
 : Atmospheric Pressure sensor
 (APS, AP Sensor)
A/F : Air Fuel Mixture

B

BBDC : Before Bottom Dead Center
BTDC : Before Top Dead Center
B+ : Battery Positive Voltage

C

CKP Sensor : Crankshaft Position Sensor
 (CKPS)
CKT : Circuit
CLP Switch : Clutch Lever Position Switch
 (Clutch Switch)
CMP Sensor : Camshaft Position Sensor
 (CMPS)
CO : Carbon Monoxide
CPU : Central Processing Unit

D

DC : Direct Current
DMC : Dealer Mode Coupler
DOHC : Double Over Head Camshaft
DRL : Daytime Running Light

E

ECM : Engine Control Module
 Engine Control Unit (ECU)
 (FI Control Unit)
ECT Sensor : Engine Coolant Temperature
 Sensor (ECTS), Water Temp.
 Sensor (WTS)
EVAP : Evaporative Emission
EVAP Canister: Evaporative Emission
 Canister (Canister)
EXC System : Exhaust Control System (EXCS)
EXC Valve : Exhaust Control Valve (EXCV)
EXCV Actuator: Exhaust Control Valve Actuator
 (EXCVA)

F

FI : Fuel Injection, Fuel Injector
FP : Fuel Pump
FPR : Fuel Pressure Regulator
FP Relay : Fuel Pump Relay

G

GEN : Generator
GND : Ground
GP Switch : Gear Position Switch

H

HC : Hydrocarbons

I

IAP Sensor : Intake Air Pressure Sensor (IAPS)
IAT Sensor : Intake Air Temperature Sensor
 (IATS)
IG : Ignition

L

LCD : Liquid Crystal Display
LED : Light Emitting Diode
 (Malfunction Indicator Lamp)
LH : Left Hand

M

MAL-Code : Malfunction Code
(Diagnostic Code)
Max : Maximum
MIL : Malfunction Indicator Lamp
(LED)
Min : Minimum

N

NOX : Nitrogen Oxides

O

OHC : Over Head Camshaft
OPS : Oil Pressure Switch

P

PCV : Positive Crankcase
Ventilation (Crankcase Breather)

R

RH : Right Hand
ROM : Read Only Memory

S

SAE : Society of Automotive Engineers
STC System : Secondary Throttle Control System
(STCS)
STP Sensor : Secondary Throttle Position Sensor
(STPS)
ST Valve : Secondary Throttle Valve (STV)
STV Actuator : Secondary Throttle Valve Actuator
(STVA)

T

TO Sensor : Tip Over Sensor (TOS)
TP Sensor : Throttle Position Sensor (TPS)
TPC Valve : Tank Pressure Control Valve (TPCV)

SAE-TO-FORMER SUZUKI TERM

This table lists SAE (Society of Automotive Engineers) J1930 terms and abbreviations which may be used in this manual in compliance with SAE recommendations, as well as their former SUZUKI names.

SAE TERM		FORMER SUZUKI TERM
FULL TERM	ABBREVIATION	
A		
Air Cleaner	ACL	Air Cleaner, Air Cleaner Box
B		
Barometric Pressure	BARO	Barometric Pressure, Atmospheric Pressure (APS, AP Sensor)
Battery Positive Voltage	B+	Battery Voltage, +B
C		
Camshaft Position Sensor	CMP Sensor	Camshaft Position Sensor (CMPS)
Crankshaft Position Sensor	CKP Sensor	Crankshaft Position Sensor (CKPS), Crank Angle
D		
Data Link Connector	DLC	Dealer Mode Coupler
Diagnostic Test Mode	DTM	—
Diagnostic Trouble Code	DTC	Diagnostic Code, Malfunction Code
E		
Electronic Ignition	EI	—
Engine Control Module	ECM	Engine Control Module (ECM) FI Control Unit, Engine Control Unit (ECU)
Engine Coolant Level	ECL	Coolant Level
Engine Coolant Temperature	ECT	Coolant Temperature, Engine Coolant Temperature Water Temperature
Engine Speed	RPM	Engine Speed (RPM)
Evaporative Emission	EVAP	Evaporative Emission
Evaporative Emission Canister	EVAP Canister	— (Canister)
Exhaust Control System	EXCS	EXC System (EXCS)
Exhaust Control Valve	EXCV	EXC Valve (EXCV)
Exhaust Control Valve Actuator	EXCVA	EXCV Actuator (EXCVA)
F		
Fan Control	FC	—
Fuel Level Sensor	—	Fuel Level Sensor, Fuel Level Gauge
Fuel Pump	FP	Fuel Pump (FP)

SAE TERM		FORMER SUZUKI TERM
FULL TERM	ABBREVIATION	
G		
Generator	GEN	Generator
Ground	GND	Ground (GND, GRD)
I		
Idle Speed Control	ISC	—
Ignition Control	IC	Electronic Spark Advance (ESA)
Ignition Control Module	ICM	—
Intake Air Temperature	IAT	Intake Air Temperature (IAT), Air Temperature
M		
Malfunction Indicator Lamp	MIL	LED Lamp Malfunction Indicator Lamp (MIL)
Manifold Absolute Pressure	MAP	Intake Air Pressure (IAP), Intake Vacuum
Mass Air Flow	MAF	Air Flow
O		
On-Board Diagnostic	OBD	Self-Diagnosis Function Diagnostic
Open Loop	OL	—
P		
Programmable Read Only Memory	PROM	—
Pulsed Secondary Air Injection	PAIR	Pulse Air Control (PAIR)
Purge Valve	Purge Valve	Purge Valve (SP Valve)
R		
Random Access Memory	RAM	—
Read Only Memory	ROM	ROM
S		
Secondary Air Injection	AIR	—
Secondary Throttle Control System	STCS	STC System (STCS)
Secondary Throttle Valve	STV	ST Valve (STV)
Secondary Throttle Valve Actuator	STVA	STV Actuator (STVA)
T		
Throttle Body	TB	Throttle Body (TB)
Throttle Body Fuel Injection	TBI	Throttle Body Fuel Injection (TBI)
Throttle Position Sensor	TP Sensor	TP Sensor (TPS)
Tank Pressure Control Valve	TPC Valve	TPC Valve (TPCV)
V		
Voltage Regulator	VR	Voltage Regulator
Volume Air Flow	VAF	Air Flow

WIRE COLOR

B	: Black	Gr	: Gray	R	: Red
Bl	: Blue	Lbl	: Light blue	W	: White
Br	: Brown	Lg	: Light green	Y	: Yellow
Dg	: Dark green	O	: Orange		
G	: Green	P	: Pink		

B/Bl	: Black with Blue tracer	B/Br	: Black with Brown tracer
B/G	: Black with Green tracer	B/Lg	: Black with Light green tracer
B/R	: Black with Red tracer	B/W	: Black with White tracer
B/Y	: Black with Yellow tracer	Bl/B	: Blue with Black tracer
Bl/G	: Blue with Green tracer	Bl/R	: Blue with Red tracer
Bl/W	: Blue with White tracer	Bl/Y	: Blue with Yellow tracer
G/B	: Green with Black tracer	G/Bl	: Green with Blue tracer
G/W	: Green with White tracer	G/Y	: Green with Yellow tracer
Gr/B	: Gray with Black tracer	Gr/R	: Gray with Red tracer
Gr/W	: Gray with White tracer	Gr/Y	: Gray with Yellow tracer
O/B	: Orange with Black tracer	O/G	: Orange with Green tracer
O/R	: Orange with Red tracer	O/W	: Orange with White tracer
O/Y	: Orange with Yellow tracer	P/B	: Pink with Black tracer
P/W	: Pink with White tracer	R/B	: Red with Black tracer
R/Bl	: Red with Blue tracer	R/W	: Red with White tracer
W/B	: White with Black tracer	W/Bl	: White with Blue tracer
W/R	: White with Red tracer	Y/B	: Yellow with Black tracer
Y/Bl	: Yellow with Blue tracer	Y/G	: Yellow with Green tracer
Y/R	: Yellow with Red tracer	Y/W	: Yellow with White tracer

GENERAL INFORMATION

1

CONTENTS

WARNING/CAUTION/NOTE	1- 2
GENERAL PRECAUTIONS.....	1- 2
SUZUKI GSX-R1000K3 ('03-MODEL)	1- 4
SERIAL NUMBER LOCATION.....	1- 4
FUEL, OIL AND ENGINE COOLANT RECOMMENDATION.....	1- 5
FUEL (FOR USA AND CANADA).....	1- 5
FUEL (FOR OTHER COUNTRIES).....	1- 5
ENGINE OIL (FOR USA).....	1- 5
ENGINE OIL (FOR OTHER COUNTRIES)	1- 5
BRAKE FLUID.....	1- 5
FRONT FORK OIL	1- 6
ENGINE COOLANT	1- 6
WATER FOR MIXING	1- 6
ANTI-FREEZE/ENGINE COOLANT.....	1- 6
LIQUID AMOUNT OF WATER/ENGINE COOLANT	1- 6
BREAK-IN PROCEDURES	1- 7
CYLINDER IDENTIFICATION	1- 7
INFORMATION LABELS.....	1- 8
SPECIFICATIONS	1- 9
DIMENSIONS AND DRY MASS	1- 9
ENGINE	1- 9
DRIVE TRAIN.....	1- 9
CHASSIS.....	1-10
ELECTRICAL	1-10
CAPACITIES	1-10
COUNTRY AND AREA CODES.....	1-11

WARNING/CAUTION/NOTE

Please read this manual and follow its instructions carefully. To emphasize special information, the symbol and the words WARNING, CAUTION and NOTE have special meanings. Pay special attention to the messages highlighted by these signal words.

▲ WARNING

Indicates a potential hazard that could result in death or injury.

CAUTION

Indicates a potential hazard that could result in motorcycle damage.

NOTE:

Indicates special information to make maintenance easier or instructions clearer.

Please note, however, that the warnings and cautions contained in this manual cannot possibly cover all potential hazards relating to the servicing, or lack of servicing, of the motorcycle. In addition to the WARNINGS and CAUTIONS stated, you must use good judgement and basic mechanical safety principles. If you are unsure about how to perform a particular service operation, ask a more experienced mechanic for advice.

GENERAL PRECAUTIONS

▲ WARNING

- * Proper service and repair procedures are important for the safety of the service mechanic and the safety and reliability of the motorcycle.
 - * When 2 or more persons work together, pay attention to the safety of each other.
 - * When it is necessary to run the engine indoors, make sure that exhaust gas is forced outdoors.
 - * When working with toxic or flammable materials, make sure that the area you work in is well-ventilated and that you follow all of the material manufacturer's instructions.
 - * Never use gasoline as a cleaning solvent.
 - * To avoid getting burned, do not touch the engine, engine oil, radiator and exhaust system until they have cooled.
- After servicing the fuel, oil, water, exhaust or brake systems, check all lines and fittings related to the system for leaks.

CAUTION

- * If parts replacement is necessary, replace the parts with Suzuki Genuine Parts or their equivalent.
- * When removing parts that are to be reused, keep them arranged in an orderly manner so that they may be reinstalled in the proper order and orientation.
- * Be sure to use special tools when instructed.
- * Make sure that all parts used in reassembly are clean. Lubricate them when specified.
- * Use the specified lubricant, bond, or sealant.
- * When removing the battery, disconnect the negative cable first and then the positive cable.
- * When reconnecting the battery, connect the positive cable first and then the negative cable, and replace the terminal cover on the positive terminal.
- * When performing service to electrical parts, if the service procedures not require use of battery power, disconnect the negative cable the battery.
- * When tightening the cylinder head and case bolts and nuts, tighten the larger sizes first. Always tighten the bolts and nuts diagonally from the inside toward outside and to the specified tightening torque.
- * Whenever you remove oil seals, gaskets, packing, O-rings, locking washers, self-locking nuts, cotter pins, circlips and certain other parts as specified, be sure to replace them with new ones. Also, before installing these new parts, be sure to remove any left over material from the mating surfaces.
- * Never reuse a circlip. When installing a new circlip, take care not to expand the end gap larger than required to slip the circlip over the shaft. After installing a circlip, always ensure that it is completely seated in its groove and securely fitted.
- * Use a torque wrench to tighten fasteners to the specified torque. Wipe off grease and oil if a thread is smeared with them.

After reassembling, check parts for tightness and proper operation.

- * To protect the environment, do not unlawfully dispose of used motor oil, engine coolant and other fluids: batteries, and tires.

To protect Earth's natural resources, properly dispose of used motorcycle and parts.

SUZUKI GSX-R1000K3 ('03-MODEL)

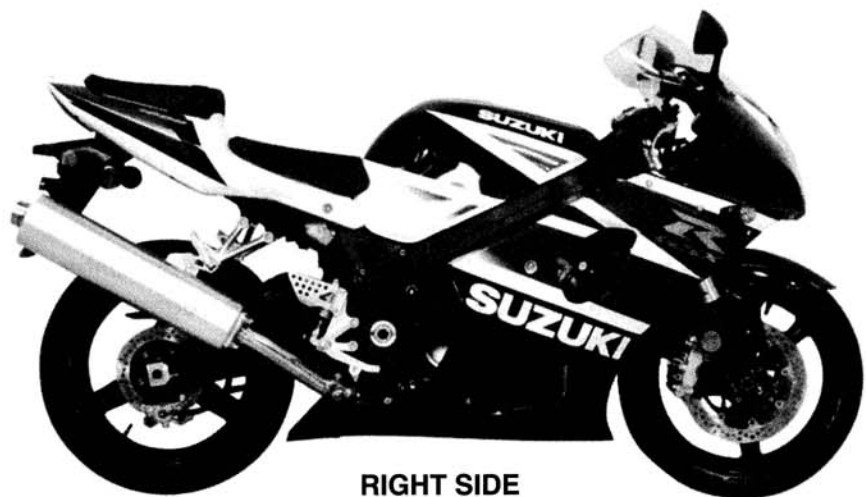

RIGHT SIDE



LEFT SIDE

- Difference between photographs and actual motorcycles depends on the markets.

SERIAL NUMBER LOCATION

The frame serial number or V.I.N. (Vehicle Identification Number) ① is stamped on the right side of the steering head pipe. The engine serial number ② is located on the rear side of the crankcase. These numbers are required especially for registering the machine and ordering spare parts.

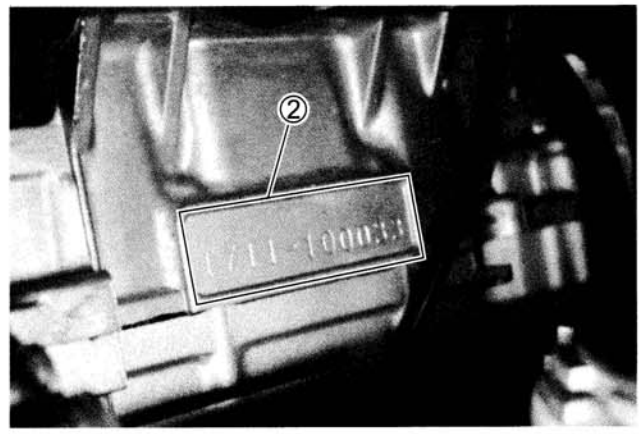
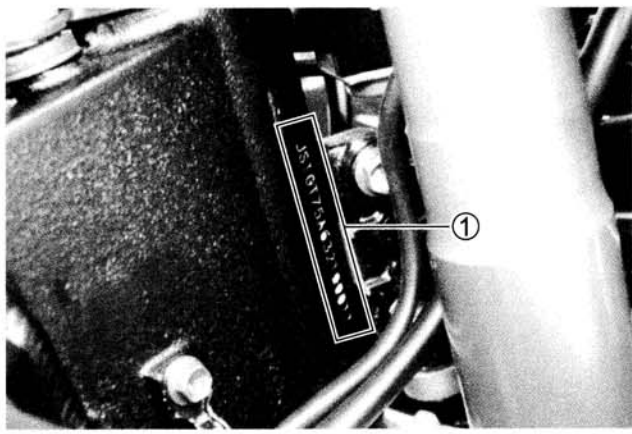

FRONT FORK OIL

Use fork oil L01 or an equivalent fork oil.

ENGINE COOLANT

Use an anti-freeze/engine coolant compatible with an aluminum radiator, mixed with distilled water only.

WATER FOR MIXING

Use distilled water only. Water other than distilled water can corrode and clog the aluminum radiator.

ANTI-FREEZE/ENGINE COOLANT

The engine coolant perform as a corrosion and rust inhibitor as well as anti-freeze. Therefore, the engine coolant should be used at all times even though the atmospheric temperature in your area does not go down to freezing point.

Suzuki recommends the use of SUZUKI COOLANT anti-freeze/engine coolant. If this is not available, use an equivalent which is compatible with an aluminum radiator.

LIQUID AMOUNT OF WATER/ENGINE COOLANT

Solution capacity (total): Approx. 2 400 ml (2.5/2.1 US/Imp qt)

For engine coolant mixture information, refer to cooling system section, page 7-2

CAUTION

Mixing of anti-freeze/engine coolant should be limited to 60 %. Mixing beyond it would reduce its efficiency. If the anti-freeze/engine coolant mixing ratio is below 50 %, rust inhabiting performance is greatly reduced. Be sure to mix it above 50 % even though the atmospheric temperature does not go down to the freezing point.

BREAK-IN PROCEDURES

During manufacture only the best possible materials are used and all machined parts are finished to a very high standard but it is still necessary to allow the moving parts to "BREAK-IN" before subjecting the engine to maximum stresses. The future performance and reliability of the engine depends on the care and restraint exercised during its early life. The general rules are as follows.

- Keep to these break-in engine speed limits:

Initial 800 km (500 miles): Below 6 000 r/min

Up to 1 600 km (1 000 miles): Below 9 000 r/min

Over to 1 600 km (1 000 miles): Below 12 500 r/min

- Upon reaching an odometer reading of 1 600 km (1 000 miles) you can subject the motorcycle to full throttle operation.

However, do not exceed 12 500 r/min at any time.

CYLINDER IDENTIFICATION

The four cylinders of this engine are identified as No.1, No.2, No.3 and No.4 cylinder, as counted from left to right (as viewed by the rider on the seat.)

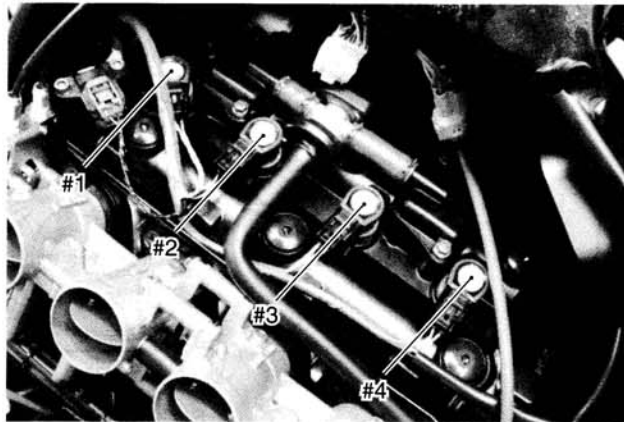

INFORMATION LABELS

	GSX-R1000	GSX-R1000UF
① Noise label	○ For E-03, 24, 33	
② Information label	○ For E-03, 28, 33	
③ Vacuum hose routing label	○ For E-33	
④ Fuel caution label	○ For E-02, 24	
⑤ Fuel information label	○	○
⑥ Manual notice label	○ For E-03, 33	
⑦ Frame caution plate	○	○
⑧ Warning screen label	○	○
⑨ Warning steering label	○	○
⑩ Tire air pressure label	○	○
⑪ Warning safety label	○	○
⑫ ICES Canada label	○ For E-28	
⑬ ID plate	○ Except E-03, 28, 33	○
⑭ E-19 ID label		○
⑮ Safety plate	○ For E-03, 28, 33	

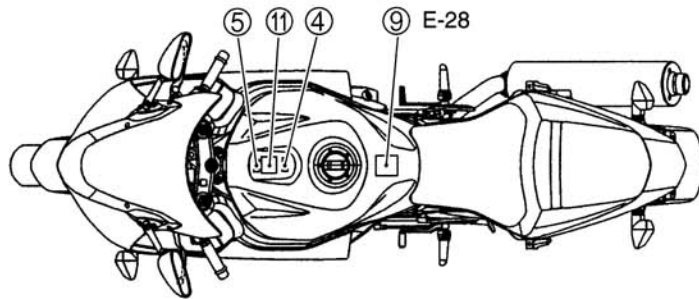
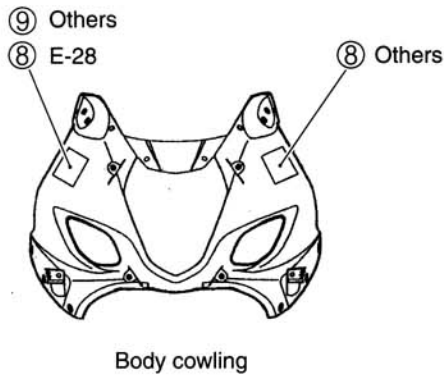

Stick the label on the right side ⑭ of rear fender.

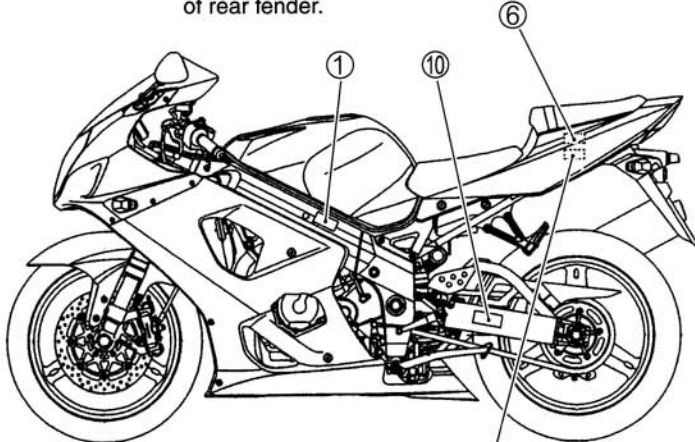
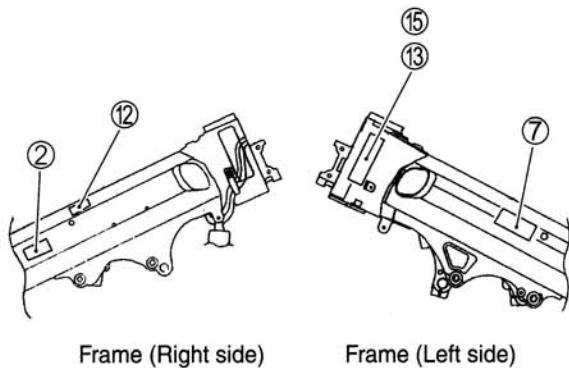

Stick the label on the left side ③ of rear fender.

SPECIFICATIONS**DIMENSIONS AND DRY MASS**

Overall length	2 070 mm (81.5 in)
Overall width	715 mm (28.1 in)
Overall height	1 145 mm (45.1 in)
Wheelbase	1 410 mm (55.5 in)
Ground clearance	130 mm (5.1 in)
Seat height	820 mm (32.3 in)
Dry mass	168 kg (370 lbs)
	169 kg (372 lbs).....E-33

ENGINE

Type	Four stroke, liquid-cooled, DOHC
Number of cylinders	4
Bore	73.0 mm (2.874 in)
Stroke	59.0 mm (2.323 in)
Displacement	988 cm ³ (60.3 cu.in)
Compression ratio	12.0:1
Fuel system	Fuel injection
Air cleaner	Non-woven fabric element
Starter system	Electric
Lubrication system	Wet sump
Idle speed	1 150 ± 100 r/min

DRIVE TRAIN

Clutch	Wet multi-plate type
Transmission	6-speed constant mesh
Gearshift pattern	1-down, 5-up
Primary reduction ratio	1.553 (73/47)
Gear ratios, Low	2.687 (43/16)
2nd	2.052 (39/19)
3rd	1.681 (37/22)
4th	1.450 (29/20)
5th	1.304 (30/23)
Top	1.208 (29/24)
Final reduction ratio	2.470 (42/17)
Drive chain	DID 530, 110 links

CHASSIS

Front suspension	Inverted telescopic, coil spring, oil damped
Rear suspension	Link type, coil spring, oil damped
Front fork stroke	120 mm (4.7 in)
Rear wheel travel	130 mm (5.1 in)
Steering angle	27 °
Caster	23.5 °
Trail	91 mm (3.6 in)
Turning radius	3.4 m (11.2 ft)
Front brake	Disc brake, twin
Rear brake	Disc brake
Front tire size	120/70 ZR 17 M/C (58 W), tubeless
Rear tire size	190/50 ZR 17 M/C (73 W), tubeless

ELECTRICAL

Ignition type	Electronic ignition (Transistorized)
Ignition timing	8 ° B.T.D.C.at 1 150 r/min.....#1-4 4 ° B.T.D.C.at 1 150 r/min.....#2-3
Spark plug	NGK CR9E or DENSO U27ESR-N
Battery	12 V 36.0 kC (10 Ah)/10 HR
Generator	Three-phase A.C.generator
Main fuse	30 A
Fuse	15/15/15/15/10/10 A
Headlight	12 V 55 W (H7) + 12 V 60/55 W (H4)
Turn signal light	12 V 18 W
License plate light	12 V 5 W
Brake light/Taillight	LED
Speedometer light	LED
Tachometer light	LED
Neutral indicator light	LED
High beam indicator light	LED
Turn signal indicator light	LED
Position/Parking light	12 V 5 W Except E-03, 24, 28, 33
Oil pressure/Coolant temperature/Fuel injection warning light	LED
Fuel level indicator light	LED
Engine RPM indicator light	LED

CAPACITIES

Fuel tank, including reserve	18 L (4.8/4.0 US/lmp gal)...Including E-33
Engine oil, oil change	3 000 ml (3.2/2.6 US/lmp qt)
with filter change	3 300 ml (3.5/2.9 US/lmp qt)
overhaul	3 600 ml (3.8/3.2 US/lmp qt)
Coolant	2 400 ml (2.5/2.1 US/lmp qt)
Front fork oil (each leg)	509 ml (17.2/17.9 US/lmp oz)

These specifications are subject to change without notice.

COUNTRY AND AREA CODES

The following codes stand for the applicable country (-ies) and area (-s).

MODEL	CODE	COUNTRY or AREA
GSX-R1000	E-02	U.K.
	E-03	U.S.A. (Except for california)
	E-19	EU
	E-24	Australia
	E-28	Canada
	E-33	California (U.S.A.)
GSX-R1000UF	E-19	EU

PERIODIC MAINTENANCE

CONTENTS

PERIODIC MAINTENANCE SCHEDULE.....	2- 2
PERIODIC MAINTENANCE CHART	2- 2
LUBRICATION POINTS.....	2- 4
MAINTENANCE AND TUNE-UP PROCEDURES.....	2- 5
AIR CLEANER	2- 5
SPARK PLUG	2- 6
VALVE CLEARANCE	2- 8
ENGINE OIL AND OIL FILTER.....	2-13
EXHAUST CONTROL VALVE.....	2-14
FUEL LINE	2-15
ENGINE IDLE SPEED.....	2-15
THROTTLE VALVE SYNCHRONIZATION.....	2-16
EVAPORATIVE EMISSION CONTROL SYSTEM (E-33 ONLY).....	2-16
PAIR (AIR SUPPLY) SYSTEM.....	2-16
THROTTLE CABLE PLAY.....	2-17
CLUTCH	2-18
COOLING SYSTEM	2-19
DRIVE CHAIN.....	2-22
BRAKE	2-25
TIRES	2-28
STEERING.....	2-29
FRONT FORK	2-29
REAR SUSPENSION	2-29
EXHAUST PIPE BOLT AND NUT.....	2-30
CHASSIS BOLTS AND NUTS	2-31
COMPRESSION PRESSURE CHECK.....	2-33
COMPRESSION TEST PROCEDURE.....	2-33
OIL PRESSURE CHECK.....	2-34

PERIODIC MAINTENANCE SCHEDULE

The chart below lists the recommended intervals for all the required periodic service work necessary to keep the motorcycle operating at peak performance and economy. Mileages are expressed in terms of kilometers, miles and time for your convenience.

IMPORTANT: The periodic maintenance intervals and service requirements have been established in accordance with EPA regulations. Following these instructions will ensure that the motorcycle will not exceed emission standards and it will also ensure the reliability and performance of the motorcycle.

NOTE:

More frequent servicing may be required on motorcycles that are used under severe conditions.

PERIODIC MAINTENANCE CHART

Item	Interval	miles	600	4 000	7 500	11 000	14 500
		km	1 000	6 000	12 000	18 000	24 000
		months	1	6	12	18	24
Air cleaner element			—	I	I	R	I
Spark plugs			—	I	R	I	R
Valve clearance			—	—	—	—	I
Exhaust valve			I	—	I	—	I
Engine oil			R	R	R	R	R
Engine oil filter			R	—	—	R	—
Fuel line			—	I	I	I	I
			Replace fuel hose every 4 years.				
Idle speed			I	I	I	I	I
Throttle valve synchronization			I (E-33 only)	—	I	—	I
Evaporative emission control system (E-33 only)			—	—	I	—	I
			Replace vapor hose every 4 years.				
PAIR (air supply) system			—	—	I	—	I
Throttle cable play			I	I	I	I	I
Clutch cable play			—	I	I	I	I
Radiator hoses			—	I	I	I	I
			Replace every 4 years.				
Engine coolant			Replace every 2 years.				
Drive chain			I	I	I	I	I
			Clean and lubricate every 1 000 km (600 miles).				
Brakes			I	I	I	I	I
Brake hoses			—	I	I	I	I
			Replace every 4 years.				

Item	Interval	miles	600	4 000	7 500	11 000	14 500
		km	1 000	6 000	12 000	18 000	24 000
		months	1	6	12	18	24
Brake fluid		—					
	Replace every 2 years.						
Tires		—					
Steering			—		—		
Front forks		—	—		—		
Rear suspension		—	—		—		
Exhaust pipe bolts and muffler bolt and nut		T	—	T	—	T	T
Chassis bolts and nuts		T	T	T	T	T	T

NOTE:

I=Inspect and clean, adjust, replace or lubricate as necessary;

R=Replace; T=Tighten

LUBRICATION POINTS

Proper lubrication is important for smooth operation and long life of each working part of the motorcycle. Major lubrication points are indicated below.

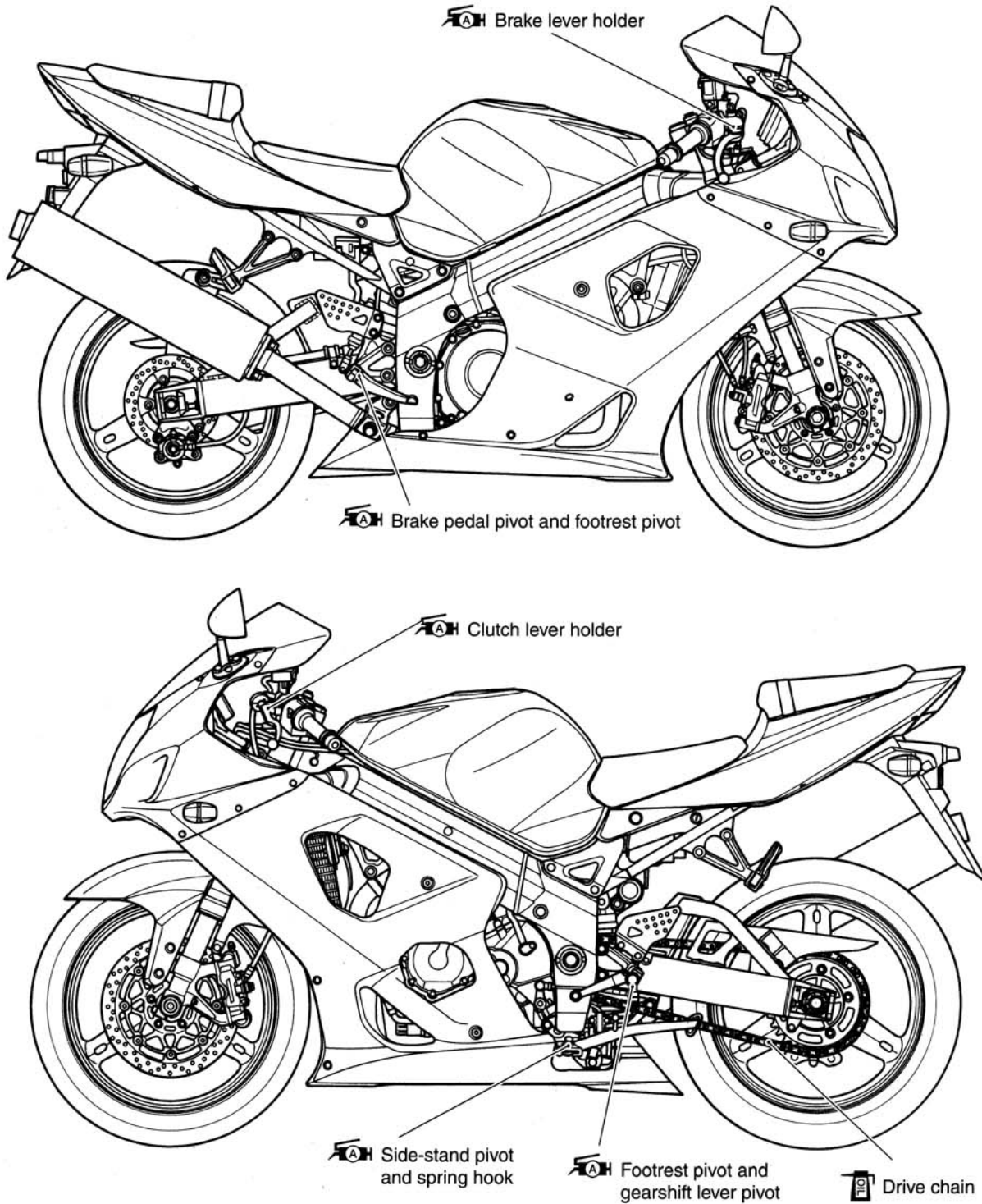

NOTE:

- * Before lubricating each part, clean off any rusty spots and wipe off any grease, oil, dirt or grime.
- * Lubricate exposed parts which are subject to rust, with a rust preventative spray whenever the motorcycle has been operated under wet or rainy conditions.

MAINTENANCE AND TUNE-UP PROCEDURES

This section describes the servicing procedures for each item of the Periodic Maintenance requirements.

AIR CLEANER

**Inspect every 6 000 km (4 000 miles, 6 months).
Replace every 18 000 km (11 000 miles, 18 months).**

- Remove the front and rear seats. (☞ 8-6)
 - Lift and support the fuel tank. (☞ 5-5)
 - Remove the air cleaner element by removing the screws.
-
- Carefully use air hose to blow the dust from the cleaner element.

NOTE:

Always apply air pressure on the throttle body side of the air cleaner element. If air pressure is applied improperly, dirt will be forced into the pores of the air cleaner element thus restricting air flow through the air cleaner element.

- Reinstall the cleaned or new air cleaner element in the reverse order of removal.

NOTE:

If driving under dusty conditions, clean the air cleaner element more frequently. Make sure that the air cleaner is in good condition at all times. The life of the engine depends largely on this component.

- Remove the drain plug from the air cleaner box to allow any water to drain out.

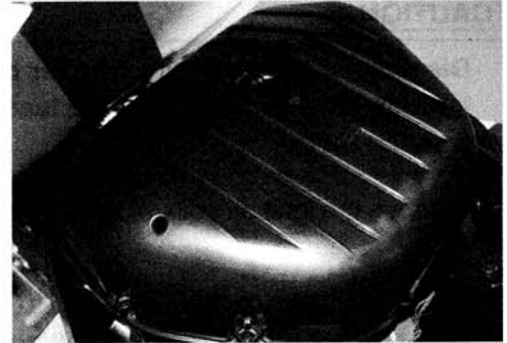

SPARK PLUG

Inspect at 6 000 km (4 000 miles, 6 months) and replace every 12 000 km (7 500 miles, 12 months) thereafter.

SPARK PLUG AND IGNITION COIL/PLUG CAP REMOVAL

- Remove the front and rear seat. (☞ 8-6)
- Lift and support the fuel tank. (☞ 5-5)
- Remove the air cleaner box. (☞ 5-15)
- Disconnect all lead wire couplers from ignition coil/plug caps.

CAUTION

Disconnect the lead wire coupler before removing the ignition coil/plug cap to avoid lead wire coupler damage.

- Remove the ignition coils/plug caps.

CAUTION

- * Do not pry up the ignition coil/plug cap with a screw driver or a bar to avoid its damage.
- * Be careful not to drop the ignition coil/plug cap to prevent short/open circuit.

- Remove the spark plugs with a spark plug wrench.

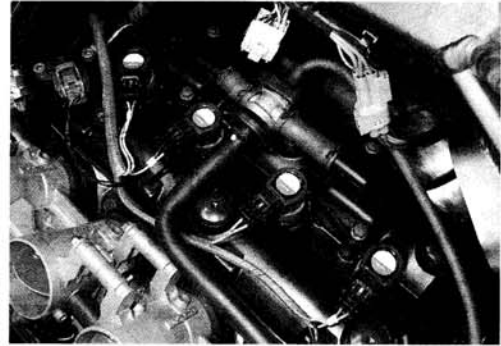

HEAT RANGE

- Check spark plug heat range by observing electrode color. If the electrode of the spark plug is wet appearing or dark color, replace the spark plug with hotter type one. If it is white or glazed appearing, replace the spark plug with colder type one.

	Hot type	Standard	Cold type
NGK	CR8E	CR9E	CR10E
ND	U24ESR-N	U27ESR-N	U31ESR-N

NOTE:

"R" type spark plug has a resistor located at the center electrode to prevent radio noise.

CARBON DEPOSITS

- Check carbon deposits on the spark plug.
- If carbon is deposited, remove it using a spark plug cleaner machine or carefully use a tool with a pointed end.

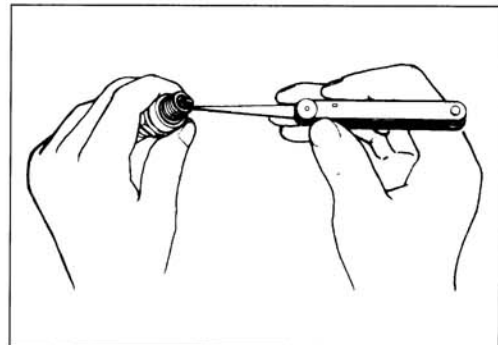

SPARK PLUG GAP

- Measure the spark plug gap with a thickness gauge.
- Adjust the spark plug gap if necessary.

DATA Spark plug gap:
 Standard: 0.7 – 0.8 mm (0.028 – 0.031 in)

TOOL 09900-20803: Thickness gauge

ELECTRODE'S CONDITION

- Check the condition of the electrode.
- If it is extremely worn or burnt, replace the spark plug. Replace the spark plug if it has a broken insulator, damaged thread, etc.

CAUTION

Confirm the thread size and reach when replacing the plug. If the reach is too short, carbon will be deposited on the screw portion of the plug hole and engine damage may result.

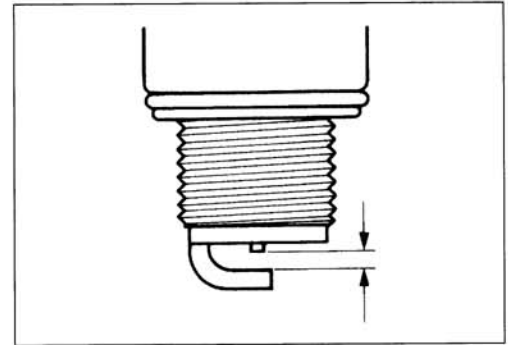

SPARK PLUG AND IGNITION COIL/PLUG CAP INSTALLATION

- Install the spark plugs to the cylinder head with fingers, and then tighten them to the specified torque.

🔧 Spark plug: 11 N·m (1.1 kgf·m, 8.0 lb-ft)

CAUTION

Do not crossthead or over tighten the spark plug, or the spark plug will damage the aluminum threads of the cylinder head.

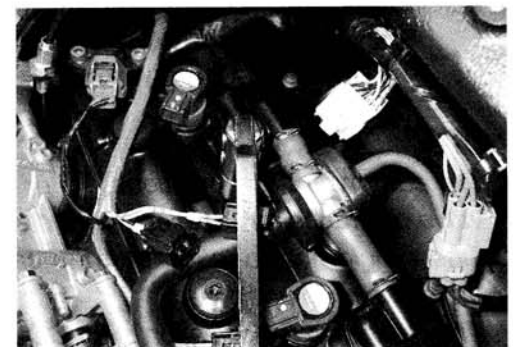

- Install the ignition coils/plug caps and connect their lead wire couplers.

CAUTION

- * Do not hit the ignition coil/plug cap with a plastic hammer when installing it.
- * Place the ignition coil/spark plug cap so that the coupler does not touch the cylinder head cover.

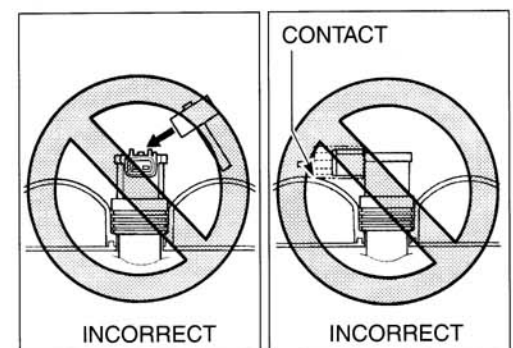
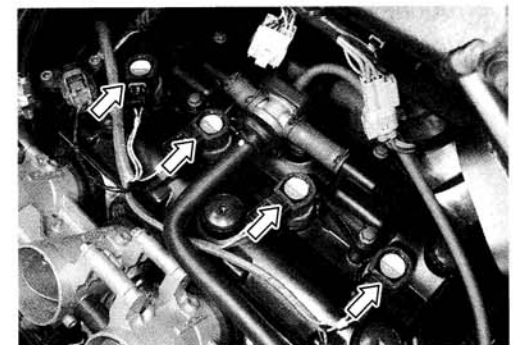

VALVE CLEARANCE

Inspect every 24 000 km (15 000 miles, 24 months).

- Remove the right under cowling. (☞ 8-3)
- Remove the front and rear seats. (☞ 8-6)
- Lift and support the fuel tank. (☞ 5-5)
- Remove the spark plugs. (☞ 2-6)
- Remove the cylinder head covers. (☞ 3-15)

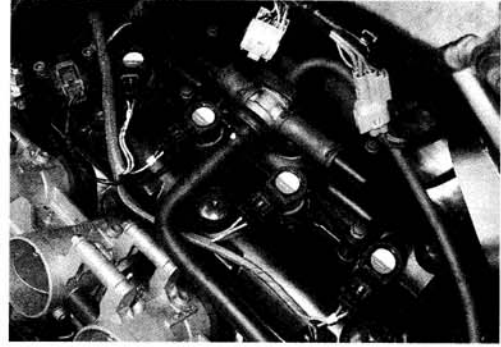

The valve clearance specification is different for intake and exhaust valves. Valve clearance must be checked and adjusted, 1) at the time of periodic inspection, 2) when the valve mechanism is serviced, and 3) when the camshafts are removed for servicing.

DATA Valve clearance (when cold):

Standard: IN. : 0.10 – 0.20 mm (0.004 – 0.008 in)

EX. : 0.20 – 0.30 mm (0.008 – 0.012 in)

NOTE:

- * The cam must be at positions, **(A)** or **(B)**, in order to check the valve clearance, or to adjust valve clearance. Clearance readings should not be taken with the cam in any other position than these two positions.
- * The clearance specification is for **COLD** state.
- * To turn the crankshaft for clearance checking, be sure to use a wrench, and rotate in the normal running direction. All spark plugs should be removed.

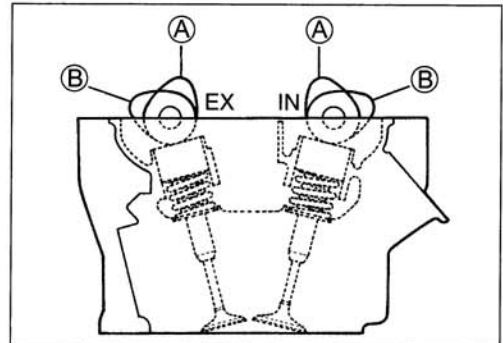

- Remove the valve timing inspection cap ①.

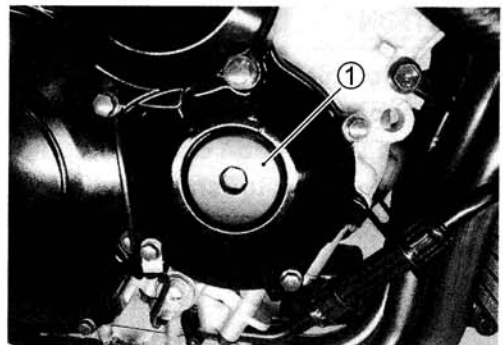

- Turn the crankshaft to bring the "Top" line on the starter clutch to the index mark and also to bring the notches (A) on the left ends of both camshafts (Ex and In) to the positions as shown.

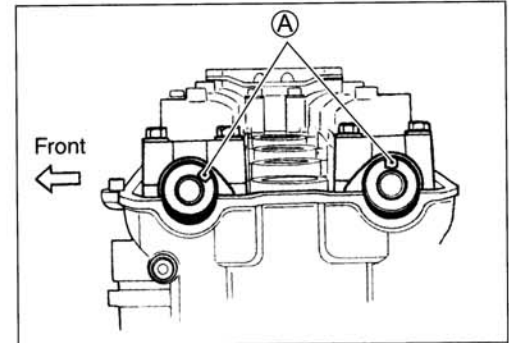
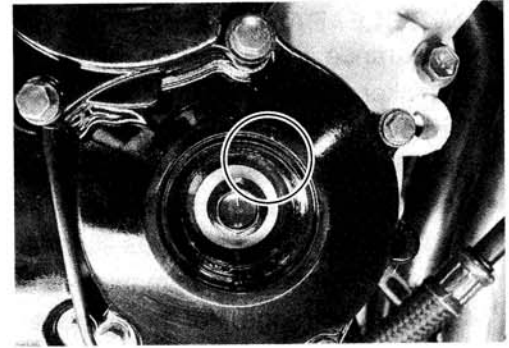

- In this condition, read the valve clearance at the valves (B) (In and Ex of No.4 cylinder, Ex of No.3 and In of No.2).
- If the clearance is out of specification, adjust the clearance. (☞ 2-10)

TOOL 09900-20803: Thickness gauge

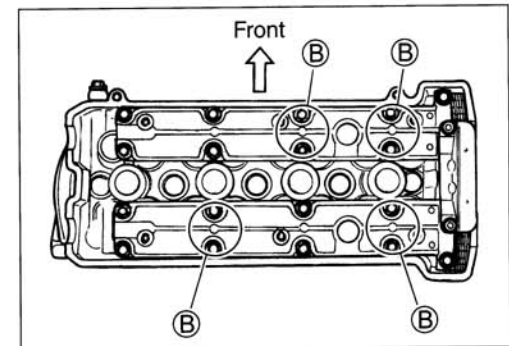

- Turn the crankshaft 360 degrees (one rotation) to bring the "TOP" line on the starter clutch to the index mark of valve timing inspection hole and also to bring the notches (A) to the position as shown.
- Read the clearance at the remaining valves (C) and adjust the clearance if necessary. (☞ 2-10)

Cam position	Notch (A) position	
	Exhaust Camshaft	Intake Camshaft
(B)	←Front	←Front
(C)	←Front	←Front

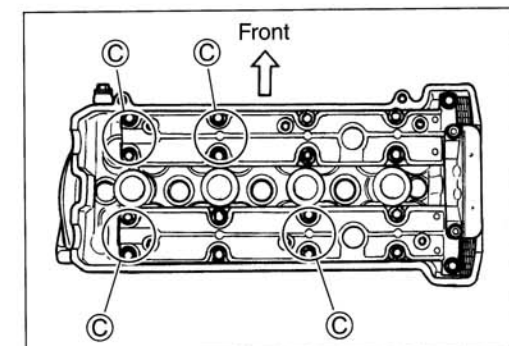
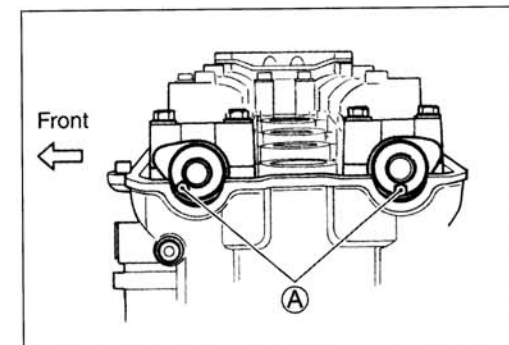

VALVE CLEARANCE ADJUSTMENT

The clearance is adjusted by replacing the existing tappet shim by a thicker or thinner shim.

- Remove the intake or exhaust camshafts. (☞ 3-16)
- Remove the tappet and shim by fingers or magnetic hand.
- Check the figures printed on the shim. These figures indicate the thickness of the shim, as illustrated.
- Select a replacement shim that will provide a clearance within the specified range. For the purpose of this adjustment, a total of 25 sizes of tappet shim are available ranging from 1.20 to 2.20 mm in steps of 0.05 mm. Fit the selected shim to the valve stem end, with numbers toward tappet. Be sure to check shim size with micrometer to ensure its size. Refer to the tappet shim selection table (☞ 2-11, 2-12) for details.

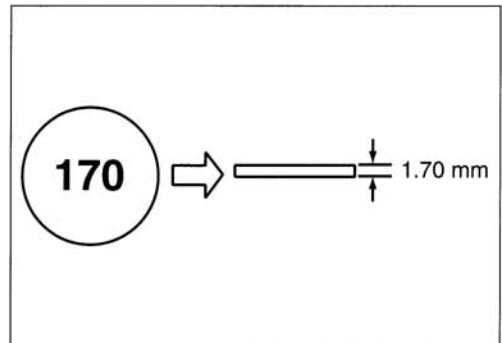
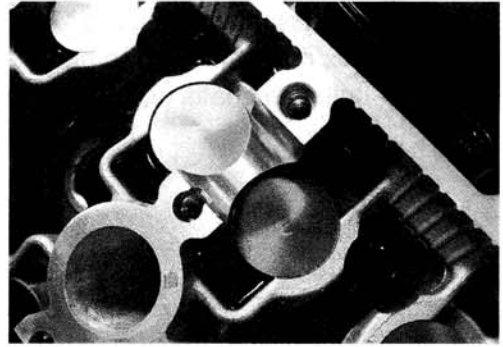
**NOTE:**

- * Be sure to apply engine oil to tappet shim top and bottom faces.
- * When seating the tappet shim, be sure the figure printed surface faces the tappet.

NOTE:

Reinstall the camshafts in the specified manner. (☞ 3-98)

- After replacing the tappet shim and camshafts, rotate the engine so that the tappet is depressed fully. This will squeeze out oil trapped between the shim and the tappet that could cause an incorrect measurement. Then check the clearance again to confirm that it is within the specified range.

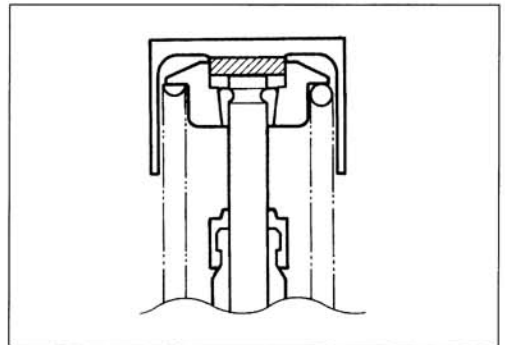

- After finishing the valve clearance adjustment, reinstall the following items.

- * Cylinder head cover (☞ 3-103)
- * Spark plug and plug cap (☞ 2-7)
- * Valve timing inspection plug (☞ 3-103)

Product: 2003-2004 Suzuki GSX-R1000 Motorcycle Service Repair Workshop Manual
 Full Download: <https://www.arepairmanual.com/downloads/2003-2004-suzuki-gsx-r1000-motocycle-service-repair-workshop-manual/>
(INTAKE SIDE)

**TAPPET SHIM SELECTION TABLE [INTAKE]
 TAPPET SHIM NO. (12892-05C00-XXX)**

		TAPPET SHIM SET (12800-05830)																				
MEASURED VALVE CLEARANCE (mm)	SUFFIX NO.	120	125	130	135	140	145	150	155	160	165	170	175	180	185	190	195	200	205	210	215	220
		SPECIFIED CLEARANCE/NO ADJUSTMENT REQUIRED																				
0.00-0.04	1.20	1.20	1.25	1.30	1.35	1.40	1.45	1.50	1.55	1.60	1.65	1.70	1.75	1.80	1.85	1.90	1.95	2.00	2.05	2.10	2.15	2.20
0.05-0.09	1.20	1.20	1.25	1.30	1.35	1.40	1.45	1.50	1.55	1.60	1.65	1.70	1.75	1.80	1.85	1.90	1.95	2.00	2.05	2.10	2.15	2.20
0.10-0.20		1.30	1.35	1.40	1.45	1.50	1.55	1.60	1.65	1.70	1.75	1.80	1.85	1.90	1.95	2.00	2.05	2.10	2.15	2.20	2.20	2.20
0.21-0.25		1.35	1.40	1.45	1.50	1.55	1.60	1.65	1.70	1.75	1.80	1.85	1.90	1.95	2.00	2.05	2.10	2.15	2.20	2.20	2.20	2.20
0.26-0.30		1.40	1.45	1.50	1.55	1.60	1.65	1.70	1.75	1.80	1.85	1.90	1.95	2.00	2.05	2.10	2.15	2.20	2.20	2.20	2.20	2.20
0.31-0.35		1.45	1.50	1.55	1.60	1.65	1.70	1.75	1.80	1.85	1.90	1.95	2.00	2.05	2.10	2.15	2.20	2.20	2.20	2.20	2.20	2.20
0.36-0.40		1.50	1.55	1.60	1.65	1.70	1.75	1.80	1.85	1.90	1.95	2.00	2.05	2.10	2.15	2.20	2.20	2.20	2.20	2.20	2.20	2.20
0.41-0.45		1.55	1.60	1.65	1.70	1.75	1.80	1.85	1.90	1.95	2.00	2.05	2.10	2.15	2.20	2.20	2.20	2.20	2.20	2.20	2.20	2.20
0.46-0.50		1.60	1.65	1.70	1.75	1.80	1.85	1.90	1.95	2.00	2.05	2.10	2.15	2.20	2.20	2.20	2.20	2.20	2.20	2.20	2.20	2.20
0.51-0.55		1.65	1.70	1.75	1.80	1.85	1.90	1.95	2.00	2.05	2.10	2.15	2.20	2.20	2.20	2.20	2.20	2.20	2.20	2.20	2.20	2.20
0.56-0.60		1.70	1.75	1.80	1.85	1.90	1.95	2.00	2.05	2.10	2.15	2.20	2.20	2.20	2.20	2.20	2.20	2.20	2.20	2.20	2.20	2.20
0.61-0.65		1.75	1.80	1.85	1.90	1.95	2.00	2.05	2.10	2.15	2.20	2.20	2.20	2.20	2.20	2.20	2.20	2.20	2.20	2.20	2.20	2.20
0.66-0.70		1.80	1.85	1.90	1.95	2.00	2.05	2.10	2.15	2.20	2.20	2.20	2.20	2.20	2.20	2.20	2.20	2.20	2.20	2.20	2.20	2.20
0.71-0.75		1.85	1.90	1.95	2.00	2.05	2.10	2.15	2.20	2.20	2.20	2.20	2.20	2.20	2.20	2.20	2.20	2.20	2.20	2.20	2.20	2.20
0.76-0.80		1.90	1.95	2.00	2.05	2.10	2.15	2.20	2.20	2.20	2.20	2.20	2.20	2.20	2.20	2.20	2.20	2.20	2.20	2.20	2.20	2.20
0.81-0.85		1.95	2.00	2.05	2.10	2.15	2.20	2.20	2.20	2.20	2.20	2.20	2.20	2.20	2.20	2.20	2.20	2.20	2.20	2.20	2.20	2.20
0.86-0.90		2.00	2.05	2.10	2.15	2.20	2.20	2.20	2.20	2.20	2.20	2.20	2.20	2.20	2.20	2.20	2.20	2.20	2.20	2.20	2.20	2.20
0.91-0.95		2.05	2.10	2.15	2.20	2.20	2.20	2.20	2.20	2.20	2.20	2.20	2.20	2.20	2.20	2.20	2.20	2.20	2.20	2.20	2.20	2.20
0.96-1.00		2.10	2.15	2.20	2.20	2.20	2.20	2.20	2.20	2.20	2.20	2.20	2.20	2.20	2.20	2.20	2.20	2.20	2.20	2.20	2.20	2.20
1.01-1.05		2.15	2.20	2.20	2.20	2.20	2.20	2.20	2.20	2.20	2.20	2.20	2.20	2.20	2.20	2.20	2.20	2.20	2.20	2.20	2.20	2.20
1.06-1.10		2.20	2.20	2.20	2.20	2.20	2.20	2.20	2.20	2.20	2.20	2.20	2.20	2.20	2.20	2.20	2.20	2.20	2.20	2.20	2.20	2.20
1.11-1.15		2.20	2.20	2.20	2.20	2.20	2.20	2.20	2.20	2.20	2.20	2.20	2.20	2.20	2.20	2.20	2.20	2.20	2.20	2.20	2.20	2.20

HOW TO USE THIS CHART:

- I. Measure valve clearance. "ENGINE IS COLD"
- II. Measure present shim size.
- III. Match clearance in vertical column with present shim size in horizontal column.

EXAMPLE

Valve clearance is 0.23 mm
 Present shim size 1.70 mm
 Shim size to be used 1.80 mm