

Product: 2007-2008 Kawasaki Z750/Z750 ABS Motorcycle Service Repair Workshop Manual  
Full Download: <https://www.arepairmanual.com/downloads/2007-2008-kawasaki-z750z750-abs-motocycle-service-repair-workshop-manual/>



**Kawasaki**

**Z750**  
**Z750 ABS**



# Motorcycle Service Manual

Sample manual. Download All pages at:

<https://www.arepairmanual.com/downloads/2007-2008-kawasaki-z750z750-abs-motocycle-service-repair-workshop-manual/>

Product: 2007-2008 Kawasaki Z750/Z750 ABS Motorcycle Service Repair Workshop Manual  
Full Download: <https://www.arepairmanual.com/downloads/2007-2008-kawasaki-z750z750-abs-motocycle-service-repair-workshop-manual/>

Sample manual. Download All pages at:  
<https://www.arepairmanual.com/downloads/2007-2008-kawasaki-z750z750-abs-motocycle-service-repair-workshop-manual/>

# Quick Reference Guide

<b>General Information</b>	<b>1</b>
<b>Periodic Maintenance</b>	<b>2</b>
<b>Fuel System (DFI)</b>	<b>3</b>
<b>Cooling System</b>	<b>4</b>
<b>Engine Top End</b>	<b>5</b>
<b>Clutch</b>	<b>6</b>
<b>Engine Lubrication System</b>	<b>7</b>
<b>Engine Removal/Installation</b>	<b>8</b>
<b>Crankshaft/Transmission</b>	<b>9</b>
<b>Wheels/Tires</b>	<b>10</b>
<b>Final Drive</b>	<b>11</b>
<b>Brakes</b>	<b>12</b>
<b>Suspension</b>	<b>13</b>
<b>Steering</b>	<b>14</b>
<b>Frame</b>	<b>15</b>
<b>Electrical System</b>	<b>16</b>
<b>Appendix</b>	<b>17</b>

This quick reference guide will assist you in locating a desired topic or procedure.

- Bend the pages back to match the black tab of the desired chapter number with the black tab on the edge at each table of contents page.
- Refer to the sectional table of contents for the exact pages to locate the specific topic required.





**Z750**  
**Z750 ABS**

# Motorcycle Service Manual

---

All rights reserved. No parts of this publication may be reproduced, stored in a retrieval system, or transmitted in any form or by any means, electronic mechanical photocopying, recording or otherwise, without the prior written permission of Quality Assurance Division/Consumer Products & Machinery Company/Kawasaki Heavy Industries, Ltd., Japan.

No liability can be accepted for any inaccuracies or omissions in this publication, although every possible care has been taken to make it as complete and accurate as possible.

The right is reserved to make changes at any time without prior notice and without incurring an obligation to make such changes to products manufactured previously. See your Motorcycle dealer for the latest information on product improvements incorporated after this publication.

All information contained in this publication is based on the latest product information available at the time of publication. Illustrations and photographs in this publication are intended for reference use only and may not depict actual model component parts.

## LIST OF ABBREVIATIONS

A	ampere(s)	lb	pound(s)
ABDC	after bottom dead center	m	meter(s)
AC	alternating current	min	minute(s)
ATDC	after top dead center	N	newton(s)
BBDC	before bottom dead center	Pa	pascal(s)
BDC	bottom dead center	PS	horsepower
BTDC	before top dead center	psi	pound(s) per square inch
°C	degree(s) Celsius	r	revolution
DC	direct current	rpm	revolution(s) per minute
F	farad(s)	TDC	top dead center
°F	degree(s) Fahrenheit	TIR	total indicator reading
ft	foot, feet	V	volt(s)
g	gram(s)	W	watt(s)
h	hour(s)	Ω	ohm(s)
L	liter(s)		

## COUNTRY AND AREA CODES

AT	Austria	GB	United Kingdom
AU	Australia	MY	Malaysia
CH	Switzerland	WVTA	Whole Vehicle Type Approval
DE	Germany		



# Foreword

This manual is designed primarily for use by trained mechanics in a properly equipped shop. However, it contains enough detail and basic information to make it useful to the owner who desires to perform his own basic maintenance and repair work. A basic knowledge of mechanics, the proper use of tools, and workshop procedures must be understood in order to carry out maintenance and repair satisfactorily. Whenever the owner has insufficient experience or doubts his ability to do the work, all adjustments, maintenance, and repair should be carried out only by qualified mechanics.

In order to perform the work efficiently and to avoid costly mistakes, read the text, thoroughly familiarize yourself with the procedures before starting work, and then do the work carefully in a clean area. Whenever special tools or equipment are specified, do not use makeshift tools or equipment. Precision measurements can only be made if the proper instruments are used, and the use of substitute tools may adversely affect safe operation.

**For the duration of the warranty period,** we recommend that all repairs and scheduled maintenance be performed in accordance with this service manual. Any owner maintenance or repair procedure not performed in accordance with this manual may void the warranty.

To get the longest life out of your vehicle.

- Follow the Periodic Maintenance Chart in the Service Manual.
- Be alert for problems and non-scheduled maintenance.
- Use proper tools and genuine Kawasaki Motorcycle parts. Special tools, gauges, and testers that are necessary when servicing Kawasaki motorcycles are introduced by the Service Manual. Genuine parts provided as spare parts are listed in the Parts Catalog.
- Follow the procedures in this manual carefully. Don't take shortcuts.
- Remember to keep complete records of maintenance and repair with dates and any new parts installed.

---

## How to Use This Manual

---

In this manual, the product is divided into its major systems and these systems make up the manual's chapters. The Quick Reference

Guide shows you all of the product's system and assists in locating their chapters. Each chapter in turn has its own comprehensive Table of Contents.

For example, if you want ignition coil information, use the Quick Reference Guide to locate the Electrical System chapter. Then, use the Table of Contents on the first page of the chapter to find the Ignition Coil section.

Whenever you see these WARNING and CAUTION symbols, heed their instructions! Always follow safe operating and maintenance practices.

### WARNING

**This warning symbol identifies special instructions or procedures which, if not correctly followed, could result in personal injury, or loss of life.**

### CAUTION

**This caution symbol identifies special instructions or procedures which, if not strictly observed, could result in damage to or destruction of equipment.**

This manual contains four more symbols (in addition to WARNING and CAUTION) which will help you distinguish different types of information.

### NOTE

○ *This note symbol indicates points of particular interest for more efficient and convenient operation.*

- Indicates a procedural step or work to be done.
- Indicates a procedural sub-step or how to do the work of the procedural step it follows. It also precedes the text of a NOTE.
- ★ Indicates a conditional step or what action to take based on the results of the test or inspection in the procedural step or sub-step it follows.

In most chapters an exploded view illustration of the system components follows the Table of Contents. In these illustrations you will find the instructions indicating which parts require specified tightening torque, oil, grease or a locking agent during assembly.

# General Information

## Table of Contents

Before Servicing .....	1-2
Model Identification.....	1-7
General Specifications.....	1-9
Unit Conversion Table .....	1-12

# 1-2 GENERAL INFORMATION

## Before Servicing

Before starting to perform an inspection service or carry out a disassembly and reassembly operation on a motorcycle, read the precautions given below. To facilitate actual operations, notes, illustrations, photographs, cautions, and detailed descriptions have been included in each chapter wherever necessary. This section explains the items that require particular attention during the removal and reinstallation or disassembly and reassembly of general parts.

Especially note the following.

### **Battery Ground**

Before completing any service on the motorcycle, disconnect the battery cables from the battery to prevent the engine from accidentally turning over. Disconnect the ground cable (-) first and then the positive (+). When completed with the service, first connect the positive (+) cable to the positive (+) terminal of the battery then the negative (-) cable to the negative terminal.

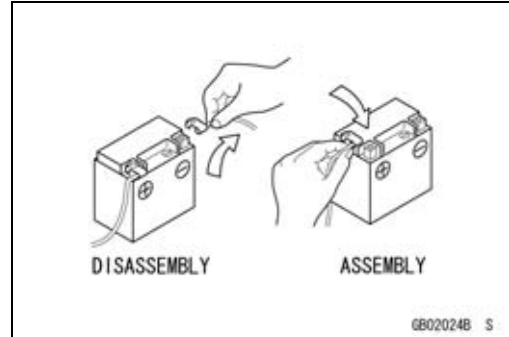

### **Edges of Parts**

Lift large or heavy parts wearing gloves to prevent injury from possible sharp edges on the parts.

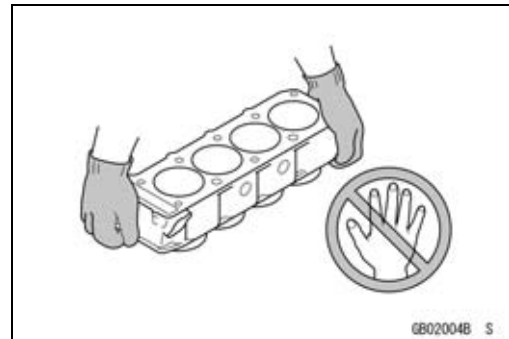

### **Solvent**

Use a high-flash point solvent when cleaning parts. High-flash point solvent should be used according to directions of the solvent manufacturer.

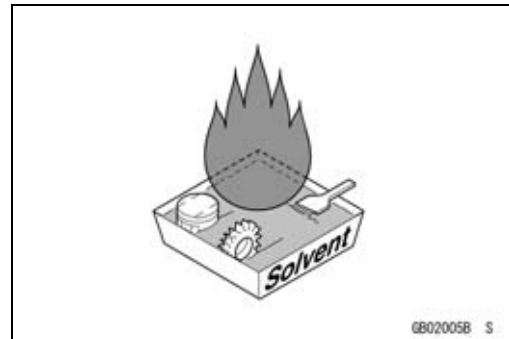

### **Cleaning Vehicle before Disassembly**

Clean the vehicle thoroughly before disassembly. Dirt or other foreign materials entering into sealed areas during vehicle disassembly can cause excessive wear and decrease performance of the vehicle.

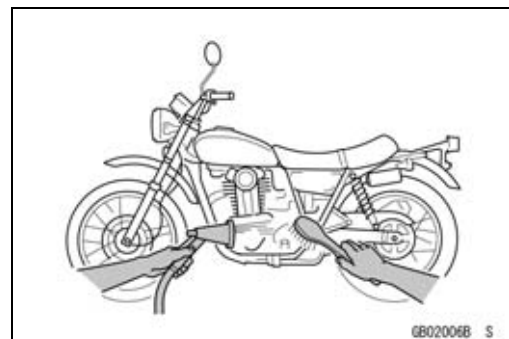

**Before Servicing**

**Arrangement and Cleaning of Removed Parts**

Disassembled parts are easy to confuse. Arrange the parts according to the order the parts were disassembled and clean the parts in order prior to assembly.

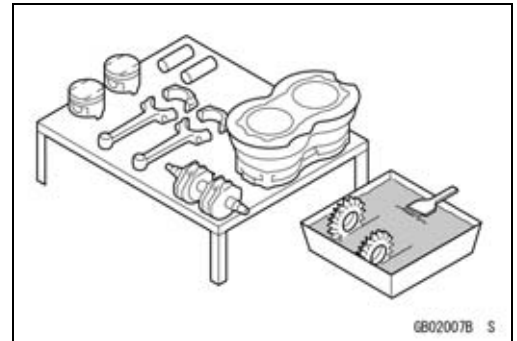

GB02007B S

**Storage of Removed Parts**

After all the parts including subassembly parts have been cleaned, store the parts in a clean area. Put a clean cloth or plastic sheet over the parts to protect from any foreign materials that may collect before re-assembly.

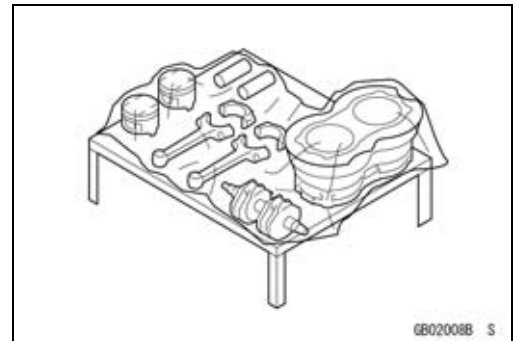

GB02008B S

**Inspection**

Reuse of worn or damaged parts may lead to serious accident. Visually inspect removed parts for corrosion, discoloration, or other damage. Refer to the appropriate sections of this manual for service limits on individual parts. Replace the parts if any damage has been found or if the part is beyond its service limit.

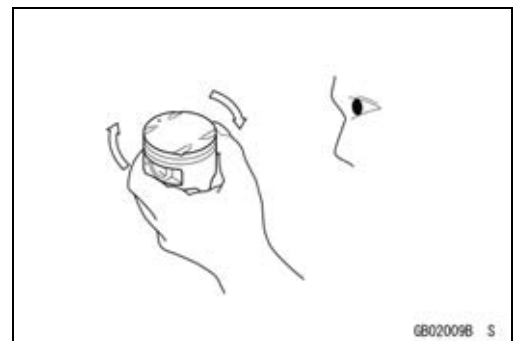

GB02009B S

**Replacement Parts**

Replacement parts must be KAWASAKI genuine or recommended by KAWASAKI. Gaskets, O-rings, oil seals, grease seals, circlips or cotter pins must be replaced with new ones whenever disassembled.

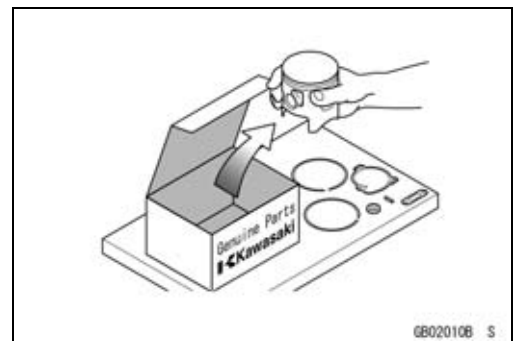

GB02010B S

**Assembly Order**

In most cases assembly order is the reverse of disassembly, however, if assembly order is provided in this Service Manual, follow the procedures given.

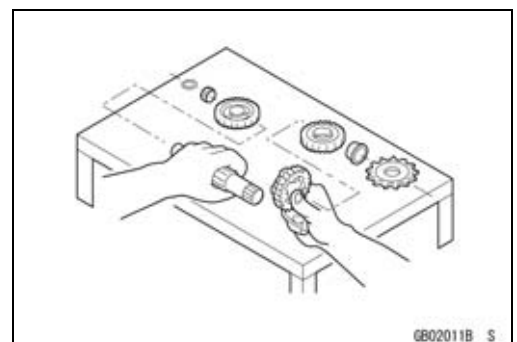

GB02011B S

## 1-4 GENERAL INFORMATION

### Before Servicing

#### **Tightening Sequence**

Generally, when installing a part with several bolts, nuts, or screws, start them all in their holes and tighten them to a snug fit. Then tighten them according to the specified sequence to prevent case warpage or deformation which can lead to malfunction. Conversely when loosening the bolts, nuts, or screws, first loosen all of them by about a quarter turn and then remove them. If the specified tightening sequence is not indicated, tighten the fasteners alternating diagonally.

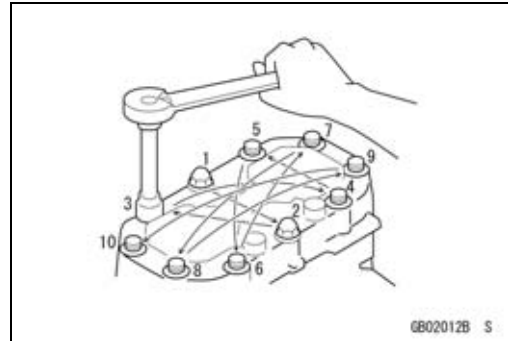

#### **Tightening Torque**

Incorrect torque applied to a bolt, nut, or screw may lead to serious damage. Tighten fasteners to the specified torque using a good quality torque wrench.

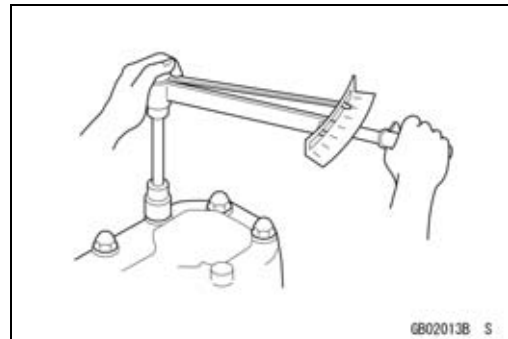

#### **Force**

Use common sense during disassembly and assembly, excessive force can cause expensive or hard to repair damage. When necessary, remove screws that have a non-permanent locking agent applied using an impact driver. Use a plastic-faced mallet whenever tapping is necessary.

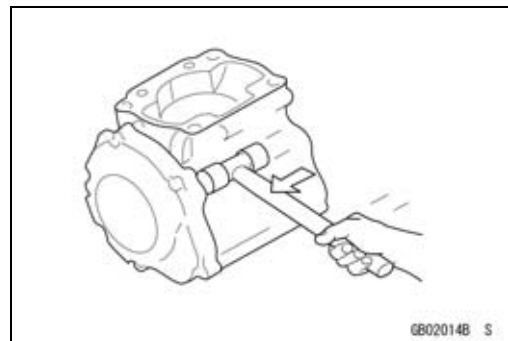

#### **Gasket, O-ring**

Hardening, shrinkage, or damage of both gaskets and O-rings after disassembly can reduce sealing performance. Remove old gaskets and clean the sealing surfaces thoroughly so that no gasket material or other material remains. Install the new gaskets and replace the used O-rings when re-assembling.

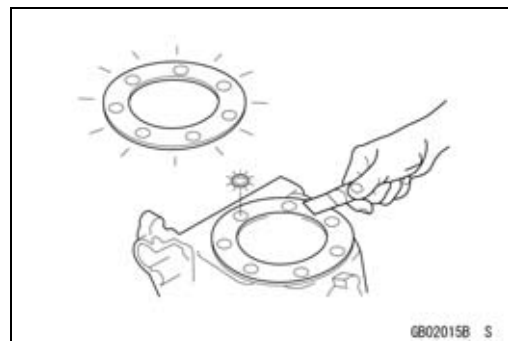

#### **Liquid Gasket, Non-permanent Locking Agent**

For applications that require Liquid Gasket or a Non-permanent Locking Agent, clean the surfaces so that no oil residue remains before applying liquid gasket or non-permanent locking agent. Do not apply them excessively. Excessive application can clog oil passages and cause serious damage.



**Before Servicing**

**Press**

For items such as bearings or oil seals that must be pressed into place, apply small amount of oil to the contact area. Be sure to maintain proper alignment and use smooth movements when installing.

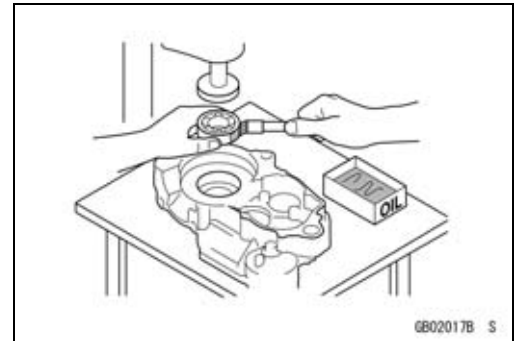

GB02017B S

**Ball Bearing and Needle Bearing**

Do not remove pressed ball or needle unless removal is absolutely necessary. Replace with new ones whenever removed. Press bearings with the manufacturer and size marks facing out. Press the bearing into place by putting pressure on the correct bearing race as shown.

Pressing the incorrect race can cause pressure between the inner and outer race and result in bearing damage.

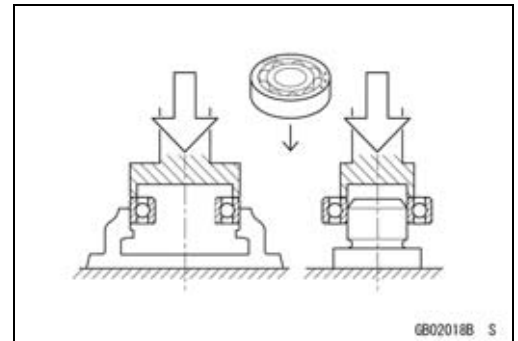

GB02018B S

**Oil Seal, Grease Seal**

Do not remove pressed oil or grease seals unless removal is necessary. Replace with new ones whenever removed. Press new oil seals with manufacture and size marks facing out. Make sure the seal is aligned properly when installing.

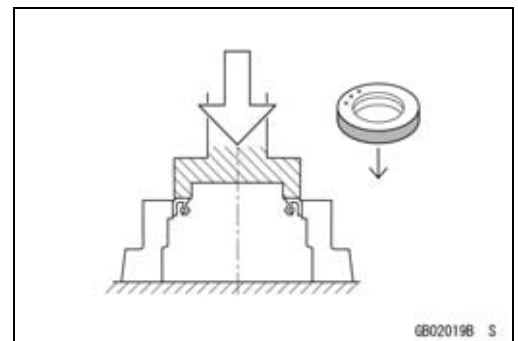

GB02019B S

Apply specified grease to the lip of seal before installing the seal.

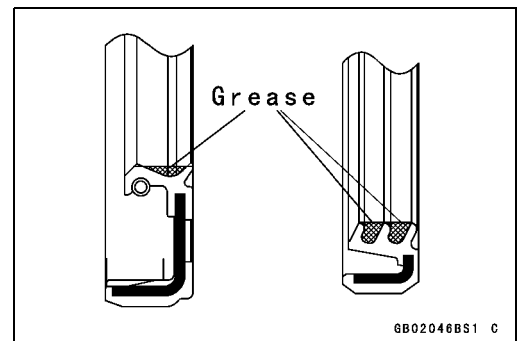

GB02046BS1 C

**Circlips, Cotter Pins**

Replace the circlips or cotter pins that were removed with new ones. Take care not to open the clip excessively when installing to prevent deformation.

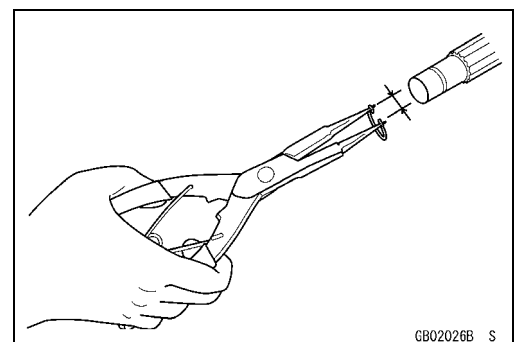

GB02026B S

# 1-6 GENERAL INFORMATION

## Before Servicing

### **Lubrication**

It is important to lubricate rotating or sliding parts during assembly to minimize wear during initial operation. Lubrication points are called out throughout this manual, apply the specific oil or grease as specified.

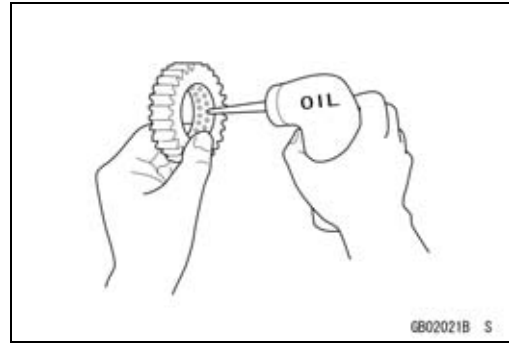

### **Direction of Engine Rotation**

When rotating the crankshaft by hand, the free play amount of rotating direction will affect the adjustment. Rotate the crankshaft to positive direction (clockwise viewed from output side).

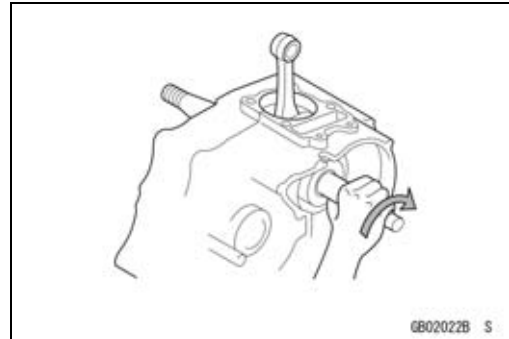

### **Electrical Wires**

A two-color wire is identified first by the primary color and then the stripe color. Unless instructed otherwise, electrical wires must be connected to those of the same color.

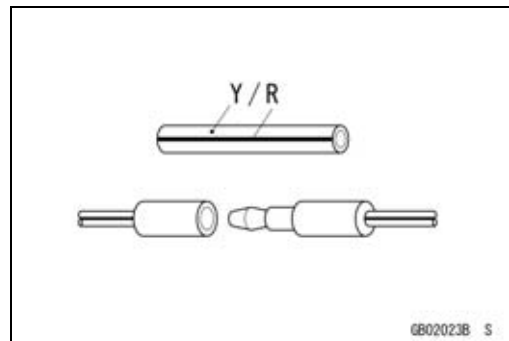

### **Instrument**

Use a meter that has enough accuracy for an accurate measurement. Read the manufacture's instructions thoroughly before using the meter. Incorrect values may lead to improper adjustments.

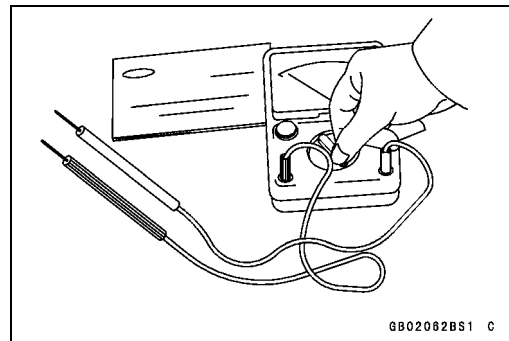

**Model Identification**

**ZR750L7F (Europe) Left Side View**



**ZR750L7F (Europe) Right Side View**





General Specifications

Items	ZR750L7F, ZR750M7F
<p><b>Dimensions</b></p> <p>Overall Length Overall Width Overall Height Wheelbase Road Clearance Seat Height Dry Mass:     ZR750L7F     ZR750M7F Curb Mass:     Front:         ZR750L7F         ZR750M7F     Rear:         ZR750L7F         ZR750M7F Fuel Tank Capacity</p>	<p>2 085 mm (82.09 in.) 805 mm (31.69 in.) 1 100 mm (43.31 in.) 1 440 mm (56.69 in.) 155 mm (6.10 in.) 815 mm (32.09 in.)  203 kg (447.6 lb) 207 kg (456.4 lb)  113 kg (249.2 lb) 115 kg (253.6 lb)  113 kg (249.2 lb) 115 kg (253.6 lb) 18.5 L (4.9 US gal.)</p>
<p><b>Performance</b></p> <p>Minimum Turning Radius</p>	<p>3.0 m (9.8 ft)</p>
<p><b>Engine</b></p> <p>Type Cooling System Bore and Stroke Displacement Compression Ratio Maximum Horsepower  Maximum Torque Carburetion System Starting System Ignition System Timing Advance Ignition Timing  Spark Plug Cylinder Numbering Method Firing Order Valve Timing:     Inlet:         Open         Close         Duration</p>	<p>4-stroke, DOHC, 4-cylinder Liquid-cooled 68.4 × 50.9 mm (2.69 × 2.00 in.) 748 cm<sup>3</sup> (45.64 cu in.) 11.3 : 1 77.7 kW (106 PS) @10 500 r/min (rpm) (MY) 73.2 kW (100 PS) @9 000 r/min (rpm) 78.0 N·m (8.0 kgf·m, 57.5 ft·lb) @8 300 r/min (rpm) FI (Fuel Injection) KEIHIN TTK32 × 4 Electric starter Battery and coil (transistorized) Electronically advanced (digital igniter) From 10° BTDC @1 100 r/min (rpm) to 37.0° BTDC @5 000 r/min (rpm) NGK CR9EK Left to right, 1-2-3-4 1-2-4-3  38° BTDC 66° ABDC 284°</p>

# 1-10 GENERAL INFORMATION

## General Specifications

Items	ZR750L7F, ZR750M7F
Exhaust: Open Close Duration Lubrication System Engine Oil: Type Viscosity Capacity	51° BBDC 25° ATDC 256° Forced lubrication (wet sump) API SE, SF or SG API SH, SJ or SL with JASO MA SAE 10W-40 3.8 L (4.0 US qt)
<b>Drive Train</b> Primary Reduction System: Type Reduction Ratio Clutch Type Transmission: Type Gear Ratios: 1st 2nd 3rd 4th 5th 6th Final Drive System: Type Reduction Ratio Overall Drive Ratio	Gear 1.714 (84/49) Wet multi disc 6-speed, constant mesh, return shift 2.571 (36/14) 1.941 (33/17) 1.556 (28/18) 1.333 (28/21) 1.200 (24/20) 1.095 (23/21) Chain drive 2.867 (43/15) 5.382 @Top gear
<b>Frame</b> Type Caster (Rake Angle) Trail Front Tire: Type Size Rim Size Rear Tire: Type Size Rim Size Front Suspension: Type Wheel Travel	Tubular, diamond 24.5° 103 mm (4.06 in.) Tubeless 120/70 ZR17 M/C (58W) 17 × 3.50 Tubeless 180/55 ZR17 M/C (73W) 17 × 5.50 Telescopic fork 120 mm (4.72 in.)

**General Specifications**

<b>Items</b>	<b>ZR750L7F, ZR750M7F</b>
Rear Suspension: Type Wheel Travel Brake Type: Front Rear	Swingarm (uni-trak) 125 mm (4.92 in.) Dual discs Single disc
<b>Electrical Equipment</b> Battery Headlight: Type Bulb Tail/Brake Light Alternator: Type Rated Output	12 V 8 Ah Semi-sealed beam 12 V 55 W × 2/55 W (Hi/Lo) 12 V 0.5/4.1 W (LED) Three-phase AC 24 A/14 V @5 000 r/min (rpm)

Specifications are subject to change without notice, and may not apply to every country.

# 1-12 GENERAL INFORMATION

## Unit Conversion Table

### Prefixes for Units:

Prefix	Symbol	Power
mega	M	× 1 000 000
kilo	k	× 1 000
centi	c	× 0.01
milli	m	× 0.001
micro	μ	× 0.000001

### Units of Mass:

kg	×	2.205	=	lb
g	×	0.03527	=	oz

### Units of Volume:

L	×	0.2642	=	gal (US)
L	×	0.2200	=	gal (imp)
L	×	1.057	=	qt (US)
L	×	0.8799	=	qt (imp)
L	×	2.113	=	pint (US)
L	×	1.816	=	pint (imp)
mL	×	0.03381	=	oz (US)
mL	×	0.02816	=	oz (imp)
mL	×	0.06102	=	cu in

### Units of Force:

N	×	0.1020	=	kg
N	×	0.2248	=	lb
kg	×	9.807	=	N
kg	×	2.205	=	lb

### Units of Length:

km	×	0.6214	=	mile
m	×	3.281	=	ft
mm	×	0.03937	=	in

### Units of Torque:

N·m	×	0.1020	=	kgf·m
N·m	×	0.7376	=	ft·lb
N·m	×	8.851	=	in·lb
kgf·m	×	9.807	=	N·m
kgf·m	×	7.233	=	ft·lb
kgf·m	×	86.80	=	in·lb

### Units of Pressure:

kPa	×	0.01020	=	kgf/cm <sup>2</sup>
kPa	×	0.1450	=	psi
kPa	×	0.7501	=	cmHg
kgf/cm <sup>2</sup>	×	98.07	=	kPa
kgf/cm <sup>2</sup>	×	14.22	=	psi
cmHg	×	1.333	=	kPa

### Units of Speed:

km/h	×	0.6214	=	mph
------	---	--------	---	-----

### Units of Power:

kW	×	1.360	=	PS
kW	×	1.341	=	HP
PS	×	0.7355	=	kW
PS	×	0.9863	=	HP

### Units of Temperature:

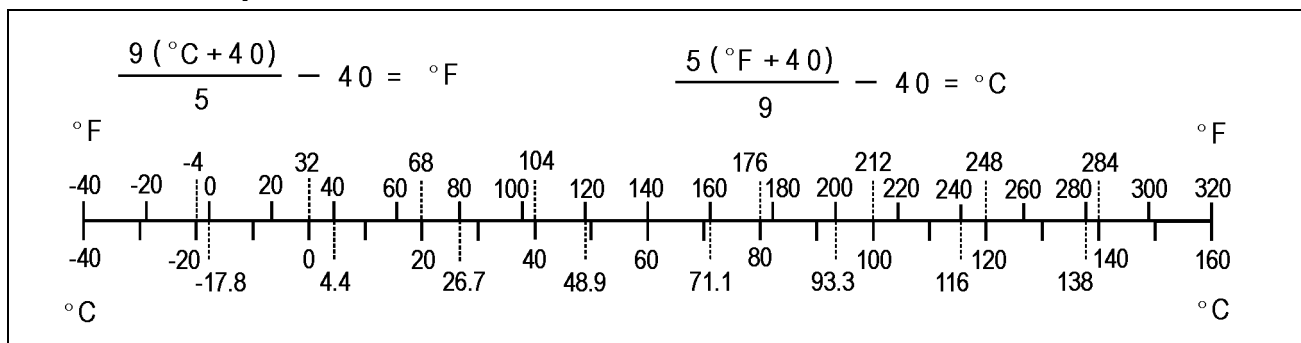

# Periodic Maintenance

## Table of Contents

Periodic Maintenance Chart .....	2-3
Torque and Locking Agent.....	2-6
Specifications .....	2-12
Special Tools .....	2-14
Periodic Maintenance Procedures.....	2-15
Fuel System (DFI).....	2-15
Air Cleaner Element Cleaning.....	2-15
Throttle Control System Inspection.....	2-15
Engine Vacuum Synchronization Inspection.....	2-16
Idle Speed Inspection .....	2-19
Idle Speed Adjustment.....	2-20
Fuel Hose Inspection (fuel leak, damage, installation condition).....	2-20
Cooling System.....	2-22
Coolant Level Inspection.....	2-22
Radiator Hose and Pipe Inspection (coolant leak, damage, installation condition) .....	2-22
Engine Top End .....	2-23
Valve Clearance Inspection .....	2-23
Valve Clearance Adjustment.....	2-24
Exhaust Butterfly Valve Cable Inspection .....	2-27
Exhaust Butterfly Valve Cable Adjustment.....	2-28
Air Suction System .....	2-31
Air Suction System Damage Inspection.....	2-31
Clutch.....	2-31
Clutch Operation Inspection.....	2-31
Wheels/Tires .....	2-32
Air Pressure Inspection.....	2-32
Wheel/Tire Damage Inspection.....	2-33
Tire Tread Wear Inspection.....	2-33
Wheel Bearing Damage Inspection .....	2-34
Drive Train .....	2-34
Drive Chain Lubrication Condition Inspection.....	2-34
Drive Chain Slack Inspection .....	2-35
Drive Chain Slack Adjustment .....	2-35
Wheel Alignment Inspection .....	2-36
Drive Chain Wear Inspection .....	2-37
Chain Guide Wear Inspection .....	2-37
Brake System .....	2-38
Brake Fluid Leak (Brake Hose and Pipe) Inspection .....	2-38
Brake Hose and Pipe Damage and Installation Condition Inspection.....	2-39
Brake Operation Inspection .....	2-39
Brake Fluid Level Inspection.....	2-39
Brake Pad Wear Inspection .....	2-40
Brake Light Switch Operation Inspection .....	2-41
Suspensions .....	2-41
Front Forks/Rear Shock Absorber Operation Inspection .....	2-41
Front Fork Oil Leak Inspection.....	2-42
Rear Shock Absorber Oil Leak Inspection .....	2-42
Rocker Arm Operation Inspection.....	2-42
Tie-Rod Operation Inspection .....	2-42
Steering System .....	2-43

## 2-2 PERIODIC MAINTENANCE

---

Steering Play Inspection .....	2-43
Steering Play Adjustment.....	2-43
Steering Stem Bearing Lubrication .....	2-44
Electrical System .....	2-45
Spark Plug Condition Inspection.....	2-45
Lights and Switches Operation Inspection.....	2-46
Headlight Aiming Inspection .....	2-48
Sidestand Switch Operation Inspection .....	2-49
Engine Stop Switch Operation Inspection.....	2-50
Others .....	2-50
Chassis Parts Lubrication .....	2-50
Bolts, Nuts and Fasteners Tightness Inspection.....	2-52
Replacement Parts .....	2-53
Air Cleaner Element Replacement.....	2-53
Fuel Hose Replacement .....	2-54
Coolant Change .....	2-56
Radiator Hose and O-ring Replacement.....	2-58
Engine Oil Change.....	2-58
Oil Filter Replacement .....	2-59
Brake Hose and Pipe Replacement.....	2-60
Brake Fluid Change .....	2-62
Master Cylinder Rubber Parts Replacement .....	2-63
Caliper Rubber Parts Replacement .....	2-64
Spark Plug Replacement .....	2-67

**Periodic Maintenance Chart**

The scheduled maintenance must be done in accordance with this chart to keep the motorcycle in good running condition. **The initial maintenance is vitally important and must not be neglected.**

**Periodic Inspection**

INSPECTION	FREQUENCY	* ODOMETER READING × 1 000 km (× 1 000 mile)							See Page
		Whichever comes first ↓ Every	1 (0.6)	6 (4)	12 (7.5)	18 (12)	24 (15)	30 (20)	
<b>Fuel System</b>									
Air cleaner element - clean					•			•	2-15
Throttle control system (play, smooth return, no drag) - inspect	year	•		•		•		•	2-15
Engine vacuum synchronization - inspect				•		•		•	2-16
Idle speed - inspect		•		•		•		•	2-19
Fuel leak (fuel hose and pipe) - inspect	year	•		•		•		•	2-20
Fuel hose and pipe damage - inspect	year	•		•		•		•	2-20
Fuel hose and pipe installation condition - inspect	year	•		•		•		•	2-20
<b>Cooling System</b>									
Coolant level - inspect		•		•		•		•	2-22
Coolant leak (radiator hose and pipe) - inspect	year	•		•		•		•	2-22
Radiator hose damage - inspect	year	•		•		•		•	2-22
Radiator hose installation condition - inspect	year	•		•		•		•	2-22
<b>Engine Top End</b>									
Valve clearance - inspect	AU Model					•			2-23
	Other than AU Model		Every 42 000 km (26 000 mile)						2-23
Exhaust butterfly valve cable - inspect		•	•	•	•	•	•	•	2-27
<b>Air Suction System</b>									
Air suction system damage - inspect				•		•		•	2-31
<b>Clutch</b>									
Clutch operation (play, disengagement, engagement) - inspect		•		•		•		•	2-31
<b>Wheels and Tires</b>									
Tire air pressure - inspect	year			•		•		•	2-32
Wheel/tire damage - inspect				•		•		•	2-33
Tire tread wear, abnormal wear - inspect				•		•		•	2-33
Wheel bearing damage - inspect	year			•		•		•	2-34
<b>Drive Train</b>									
Drive chain lubrication condition - inspect #		Every 600 km (400 mile)							2-34
Drive chain slack - inspect #		Every 1 000 km (600 mile)							2-35
Drive chain wear - inspect #				•		•		•	2-37
Drive chain guide wear - inspect				•		•		•	2-37

## 2-4 PERIODIC MAINTENANCE

### Periodic Maintenance Chart

INSPECTION	FREQUENCY	Whichever comes first ↓ Every	* ODOMETER READING × 1 000 km (× 1 000 mile)						See Page
			1 (0.6)	6 (4)	12 (7.5)	18 (12)	24 (15)	30 (20)	
<b>Brake System</b>									
Brake fluid leak (brake hose and pipe) - inspect	year	•	•	•	•	•	•	•	2-38
Brake hose and pipe damage - inspect	year	•	•	•	•	•	•	•	2-39
Brake hose and pipe installation condition - inspect	year	•	•	•	•	•	•	•	2-39
Brake operation (effectiveness, play, no drag) - inspect	year	•	•	•	•	•	•	•	2-39
Brake fluid level - inspect	6 months	•	•	•	•	•	•	•	2-39
Brake pad wear - inspect #			•	•	•	•	•	•	2-40
Brake light switch operation - inspect		•	•	•	•	•	•	•	2-41
<b>Suspensions</b>									
Front forks/rear shock absorber operation (damping and smooth stroke) - inspect				•		•		•	2-41
Front forks/rear shock absorber oil leak - inspect	year			•		•		•	2-42
Rocker arm operation - inspect				•		•		•	2-42
Tie-rods operation - inspect				•		•		•	2-42
<b>Steering System</b>									
Steering play - inspect	year	•		•		•		•	2-43
Steering stem bearings - lubricate	2 years					•			2-44
<b>Electrical System</b>									
Spark plug condition - inspect				•		•		•	2-45
Lights and switches operation - inspect	year			•		•		•	2-46
Headlight aiming - inspect	year			•		•		•	2-48
Sidestand switch operation - inspect	year			•		•		•	2-49
Engine stop switch operation - inspect	year			•		•		•	2-50
<b>Others</b>									
Chassis parts - lubricate	year			•		•		•	2-50
Bolts and nuts tightness - inspect		•		•		•		•	2-52

#: Service more frequently when operating in severe conditions; dusty, wet, muddy, high speed or frequent starting/stopping.

\*: For higher odometer readings, repeat at the frequency interval established here.

## PERIODIC MAINTENANCE 2-5

### Periodic Maintenance Chart

#### Periodic Replacement Parts

CHANGE/REPLACE ITEM	FREQUENCY	* ODOMETER READING × 1 000 km (× 1 000 mile)					See Page
	Whichever comes first ↓ Every	1 (0.6)	12 (7.5)	24 (15)	36 (24)	48 (30)	
Air cleaner element #					•		2-53
Fuel hose	4 years					•	2-54
Coolant	3 years				•		2-56
Radiator hose and O-ring	3 years				•		2-58
Engine oil #	year	•	•	•	•	•	2-58
Oil filter	year	•	•	•	•	•	2-59
Brake hose and pipe	4 years					•	2-60
Brake fluid	2 years			•		•	2-62
Rubber parts of master cylinder and caliper	4 years					•	2-63, 2-64
Spark plug			•	•	•	•	2-67

#: Service more frequently when operating in severe conditions; dusty, wet, muddy, high speed or frequent starting/stopping.

\*: For higher odometer readings, repeat at the frequency interval established here.

## 2-6 PERIODIC MAINTENANCE

### Torque and Locking Agent

The following tables list the tightening torque for the major fasteners requiring use of a non-permanent locking agent or silicone sealant etc.

Letters used in the "Remarks" column mean:

AL: Tighten the two clamp bolts alternately two times to ensure even tightening torque.

EO: Apply engine oil.

G: Apply grease.

HG: Apply high-temperature grease.

L: Apply a non-permanent locking agent.

MO: Apply molybdenum disulfide grease oil solution.

(mixture of the engine oil and molybdenum disulfide grease in a weight ratio 10 : 1)

R: Replacement Parts

S: Follow the specified tightening sequence.

Si: Apply silicone grease (ex. PBC grease).

SS: Apply silicone sealant.

Fastener	Torque			Remarks
	N·m	kgf·m	ft·lb	
<b>Fuel System (DFI)</b>				
Air Cleaner Duct Screws	3.8	0.39	34 in·lb	
Air Cleaner Housing Mounting Bolts	9.8	1.0	87 in·lb	
Air Cleaner Housing Tapping Screws	1.2	0.12	11 in·lb	
Air Duct Clamp Bolts	2.0	0.20	18 in·lb	
Bypass Screws	0.2	0.02	1.8 in·lb	
Camshaft Position Sensor Bolt	12	1.2	106 in·lb	
Crankshaft Sensor Bolts	5.9	0.60	52 in·lb	
Delivery Pipe Assy Mounting Screws	3.4	0.35	30 in·lb	
Exhaust Butterfly Valve Actuator Bracket Bolt	6.9	0.70	61 in·lb	
Exhaust Butterfly Valve Actuator Mounting Bolts	6.9	0.70	61 in·lb	
Exhaust Butterfly Valve Actuator Pulley Bolt	5.0	0.51	44 in·lb	
Fuel Pump Bolts	9.8	1.0	87 in·lb	L, S
Idle Adjusting Cable Clamp Screw	3.4	0.35	30 in·lb	
Oxygen Sensor (Equipped Models)	44.1	4.50	32.5	
Speed Sensor Bolt	12	1.2	106 in·lb	
Throttle Body Assy Holder Bolts	13	1.3	115 in·lb	
Throttle Body Assy Holder Clamp Bolts	2.0	0.20	18 in·lb	
Throttle Cable Plate Bolt	5.9	0.60	52 in·lb	
Throttle Link Holder Screws	2.0	0.20	18 in·lb	
Vehicle-down Sensor Bolts	6.0	0.61	53 in·lb	
Water Temperature Sensor	25	2.5	18	
<b>Cooling System</b>				
Coolant Drain Bolt (Cylinder)	9.8	1.0	87 in·lb	
Coolant Drain Bolt (Water Pump)	11	1.1	97 in·lb	
Radiator Bracket Mounting Bolt	6.9	0.70	61 in·lb	
Radiator Lower Bolt	6.9	0.70	61 in·lb	
Radiator Upper Bolts	6.9	0.70	61 in·lb	
Radiator (Water) Hose Clamp Screws	3.0	0.31	27 in·lb	
Reserve Tank Bolts	9.8	1.0	87 in·lb	

## PERIODIC MAINTENANCE 2-7

### Torque and Locking Agent

Fastener	Torque			Remarks
	N·m	kgf·m	ft·lb	
Thermostat Bracket Bolt	6.9	0.70	61 in·lb	
Thermostat Housing Ground Bolt	6.9	0.70	61 in·lb	
Thermostat Housing Screws	5.9	0.60	52 in·lb	
Water Pipe Bolts	11	1.1	97 in·lb	L
Water Pump Cover Bolts	11	1.1	97 in·lb	
Water Pump Impeller Bolt	9.8	1.0	87 in·lb	
Water Temperature Sensor	25	2.5	18	
<b>Engine Top End</b>				
Air Suction Valve Cover Bolts	9.8	1.0	87 in·lb	
Camshaft Cap Bolts (L = 45 mm)	12	1.2	106 in·lb	S
Camshaft Cap Bolts (L = 40 mm)	12	1.2	106 in·lb	S
Camshaft Chain Tensioner Cap Bolt	20	2.0	15	
Camshaft Chain Tensioner Mounting Bolts	11	1.1	97 in·lb	
Coolant Drain Bolt (Cylinder)	9.8	1.0	87 in·lb	
Cylinder Head Bolts (M10 New Bolts)	54	5.5	40	S
Cylinder Head Bolts (M10 Used Bolts)	49	5.0	36	S
Cylinder Head Bolts (M6)	12	1.2	106 in·lb	S
Cylinder Head Cover Bolts	9.8	1.0	87 in·lb	S
Cylinder Head Jacket Plugs	22	2.2	16	L
Exhaust Butterfly Valve Actuator Bracket Bolt	6.9	0.70	61 in·lb	
Exhaust Butterfly Valve Actuator Mounting Bolts	6.9	0.70	61 in·lb	
Exhaust Butterfly Valve Actuator Pulley Bolt	5.0	0.51	44 in·lb	
Exhaust Butterfly Valve Cable Adjuster Locknuts	6.9	0.70	61 in·lb	
Exhaust Butterfly Valve Cable Locknuts	6.9	0.70	61 in·lb	
Exhaust Butterfly Valve Cover Bolts	6.9	0.70	61 in·lb	
Exhaust Pipe Manifold Holder Nuts	17	1.7	13	S
Front Camshaft Chain Guide Bolt (Lower)	12	1.2	106 in·lb	
Front Camshaft Chain Guide Bolt (Upper)	25	2.5	18	
Muffler Body Clamp Bolt	15	1.5	11	S
Muffler Body Mounting Bolt	4.9	0.50	43 in·lb	S
Muffler Body Mounting Nut	34	3.5	25	S
Muffler Body Side Cover Bolts	6.9	0.70	61 in·lb	
Rear Camshaft Chain Guide Bolt	25	2.5	18	
Spark Plugs	13	1.3	115 in·lb	
Throttle Body Assy Holder Bolts	13	1.3	115 in·lb	
Throttle Body Assy Holder Clamp Bolts	2.0	0.20	18 in·lb	
<b>Clutch</b>				
Clutch Cover Mounting Bolts	11	1.1	97 in·lb	
Clutch Hub Nut	135	13.8	99.6	R
Clutch Lever Clamp Bolts	7.8	0.80	69 in·lb	S
Clutch Spring Bolts	8.8	0.90	78 in·lb	
Oil Filler Plug	2.0	0.20	18 in·lb	

## 2-8 PERIODIC MAINTENANCE

### Torque and Locking Agent

Fastener	Torque			Remarks
	N·m	kgf·m	ft·lb	
<b>Engine Lubrication System</b>				
Coolant Drain Bolt (Water Pump)	11	1.1	97 in·lb	
Engine Oil Drain Bolt	29	3.0	21	
Oil Filter	17	1.7	13	G, R
Oil Filter Holder	78	8.0	58	EO
Oil Filler Plug	2.0	0.20	18 in·lb	
Oil Jet Nozzle Bolts	6.9	0.70	61 in·lb	L
Oil Pan Bolts	11	1.1	97 in·lb	
Oil Pan Side Dummy Bolts	6.9	0.70	61 in·lb	
Oil Passage Plugs	20	2.0	15	L
Oil Pipe Holder Bolts	13	1.3	115 in·lb	L
Oil Pressure Relief Valve	15	1.5	11	L
Oil Pressure Switch	15	1.5	11	SS
Oil Pressure Switch Terminal Bolt	2.0	0.20	18 in·lb	HG
Water Pump Cover Bolts	11	1.1	97 in·lb	
Water Pump Impeller Bolt	9.8	1.0	87 in·lb	
<b>Engine Removal/Installation</b>				
Adjusting Collar Lock Bolt	34	3.5	25	S
Adjusting Collar Locknut	49	5.0	36	S
Engine Ground Cable Terminal Bolt	9.8	1.0	87 in·lb	
Front Engine Mounting Bolts	44	4.5	32	S
Lower Engine Mounting Nut	44	4.5	32	S
Middle Engine Mounting Nut	44	4.5	32	S
Rear Engine Bracket Bolts	25	2.5	18	S
Subframe Bolts	25	2.5	18	S
Upper Engine Bracket Bolts	44	4.5	32	S
<b>Crankshaft/Transmission</b>				
Breather Plate Bolts (M6)	9.8	1.0	87 in·lb	L
Breather Plate Bolts (M5)	5.9	0.60	52 in·lb	L
Connecting Rod Big End Nuts	see the text	←	←	MO
Crankcase Bolts (M9)	42	4.3	31	MO, S
Crankcase Bolts (M8)	27	2.8	20	S
Crankcase Bolts (M7)	20	2.0	15	S
Crankcase Bolts (M6)	12	1.2	106 in·lb	S
Front Footpeg Bracket Bolts	25	2.5	18	
Gear Positioning Lever Bolt	12	1.2	106 in·lb	
Neutral Switch	15	1.5	11	
Oil Jet Nozzle Bolts	6.9	0.70	61 in·lb	L
Oil Passage Plugs	20	2.0	15	L
Oil Pipe Holder Bolts	13	1.3	115 in·lb	L
Shift Drum Bearing Holder Bolt	13	1.3	115 in·lb	L
Shift Drum Bearing Holder Screw	5.9	0.60	52 in·lb	L
Shift Drum Cam Holder Bolt	12	1.2	106 in·lb	L

## PERIODIC MAINTENANCE 2-9

### Torque and Locking Agent

Fastener	Torque			Remarks
	N·m	kgf·m	ft·lb	
Shift Lever Bolt	6.9	0.70	61 in·lb	
Shift Pedal Mounting Bolt	34	3.5	25	L
Shift Shaft Return Spring Pin	29	3.0	21	L
Starter Motor Clutch Bolts	12	1.2	106 in·lb	L
Tie-Rod Locknuts	6.9	0.70	61 in·lb	
<b>Wheels/Tires</b>				
Front Axle	108	11.0	79.7	
Front Axle Clamp Bolt	20	2.0	15	
Rear Axle Nut	108	11.0	79.7	
<b>Final Drive</b>				
Engine Sprocket Cover Bolts	9.8	1.0	87 in·lb	
Engine Sprocket Cover Plate Bolts	9.8	1.0	87 in·lb	
Engine Sprocket Nut	125	12.7	92.2	MO
Rear Axle Nut	108	11.0	79.7	
Rear Sprocket Nuts	59	6.0	44	
<b>Brakes</b>				
Bleed Valves	7.8	0.80	69 in·lb	
Brake Hose Banjo Bolts	25	2.5	18	
Brake Lever Pivot Bolt	1.0	0.10	9 in·lb	Si
Brake Lever Pivot Bolt Locknut	5.9	0.60	52 in·lb	
Brake Pedal Bolt	34	3.5	25	L
Brake Pipe Joint Nuts (ABS Equipped Models)	18	1.8	13	
Front Brake Disc Mounting Bolts	27	2.8	20	L
Front Brake Light Switch Screw	1.2	0.12	11 in·lb	
Front Brake Pad Pin Plugs	2.5	0.25	25 in·lb	
Front Brake Pad Pins	17.2	1.8	13	
Front Brake Reservoir Cap Stopper Screw	1.2	0.12	11 in·lb	
Front Caliper Holder Pin Bolt	22	2.2	16	L, Si
Front Caliper Mounting Bolts	25	2.5	18	
Front Master Cylinder Clamp Bolts	8.8	0.90	78 in·lb	S
Rear Brake Disc Mounting Bolts	27	2.8	20	L
Rear Brake Pad Pin	17.2	1.8	13	
Rear Brake Pad Pin Plug	2.5	0.25	25 in·lb	
Rear Caliper Mounting Bolt	22	2.2	16	
Rear Caliper Pin Bolt	27	2.8	20	Si
Rear Master Cylinder Mounting Bolts	25	2.5	18	
Rear Master Cylinder Push Rod Locknut	17.2	1.8	13	
<b>Suspension</b>				
Front Axle Clamp Bolt	20	2.0	15	
Front Fork Bottom Allen Bolts	40	4.1	30	L
Front Fork Top Plugs	23	2.3	17	
Lower Front Fork Clamp Bolts	21	2.1	15	AL
Piston Rod Nuts	15	1.5	11	

## 2-10 PERIODIC MAINTENANCE

Product: 2007-2008 Kawasaki Z750/ABS ABS Motorcycle Service Repair Workshop Manual

Full Download: [https://www.irepairmanual.com/downloads/2007-2008-kawasaki-z](https://www.irepairmanual.com/downloads/2007-2008-kawasaki-z750z750-abs-motorcycle-service-repair-workshop-manual/)

[750z750-abs-motorcycle-service-repair-workshop-manual/](https://www.irepairmanual.com/downloads/2007-2008-kawasaki-z750z750-abs-motorcycle-service-repair-workshop-manual/)

Fastener	Torque			Remarks
	N·m	kgf·m	ft·lb	
Rear Shock Absorber Nut (Lower)	34	3.5	25	
Rear Shock Absorber Nut (Upper)	34	3.5	25	
Swingarm Pivot Shaft	9.8	1.0	87 in·lb	
Swingarm Pivot Shaft Locknut	98	10.0	72.3	
Swingarm Pivot Shaft Nut	108	11.0	79.7	
Tie-Rod Nuts	59	6.0	44	
Uni-Trak Rocker Arm Nut	34	3.5	25	
Upper Front Fork Clamp Bolts	20	2.0	15	
<b>Steering</b>				
Handlebar Holder Bolts	25	2.5	18	S
Handlebar Lower Clamp Nuts	34	3.5	25	
Lower Front Fork Clamp Bolts	21	2.1	15	AL
Steering Stem Head Bolt	108	11.0	79.7	
Steering Stem Nut	27	2.8	20	
Switch Housing Screws	3.5	0.36	31 in·lb	
Upper Front Fork Clamp Bolts	20	2.0	15	
<b>Frame</b>				
Front Fender Bolts	3.9	0.40	35 in·lb	
Front Footpeg Bracket Bolts	25	2.5	18	
Rear Footpeg Bracket Bolts	25	2.5	18	
Sidestand Bolt	44	4.5	32	
Sidestand Switch Bolt	8.8	0.90	78 in·lb	L
<b>Electrical System</b>				
Alternator Cover Bolts	11	1.1	97 in·lb	
Alternator Lead Holding Plate Bolt	12	1.2	106 in·lb	L
Alternator Rotor Bolt	155	15.8	114	S
Camshaft Position Sensor Bolt	12	1.2	106 in·lb	
Crankshaft Sensor Bolts	5.9	0.60	52 in·lb	
Crankshaft Sensor Cover Bolts	11	1.1	97 in·lb	
Engine Ground Cable Terminal Bolt	9.8	1.0	87 in·lb	
Front Brake Light Switch Screw	1.2	0.12	11 in·lb	
Fuel Level Sensor Bolts	6.9	0.70	61 in·lb	L
License Plate Light Cover Mounting Screws	0.9	0.09	8 in·lb	
License Plate Light Mounting Screws	1.2	0.12	11 in·lb	
Meter Mounting Screws	1.2	0.12	11 in·lb	
Neutral Switch	15	1.5	11	
Oil Pressure Switch	15	1.5	11	SS
Oil Pressure Switch Terminal Bolt	2.0	0.20	18 in·lb	HG
Oxygen Sensor (Equipped Models)	44.1	4.50	32.5	
Regulator/Rectifier Bolts	6.9	0.70	61 in·lb	
Regulator/Rectifier Bracket Bolts	6.9	0.70	61 in·lb	L
Sidestand Switch Bolt	8.8	0.90	78 in·lb	L
Spark Plugs	13	1.3	115 in·lb	

Sample manual Download All pages at:

<https://www.irepairmanual.com/downloads/2007-2008-kawasaki-z750z750-abs-motorcycle-service-repair-workshop-manual/>