

Product: 2007 Kawasaki Ninja ZX-6R Motorcycle Service Repair Workshop Manual  
Full Download: <https://www.arepairmanual.com/downloads/2007-kawasaki-ninja-zx-6r-motocycle-service-repair-workshop-manual/>

# Kawasaki

# Ninja ZX-6R



# Motorcycle Service Manual

Sample manual. Download All pages at:

<https://www.arepairmanual.com/downloads/2007-kawasaki-ninja-zx-6r-motocycle-service-repair-workshop-manual/>

Product: 2007 Kawasaki Ninja ZX-6R Motorcycle Service Repair Workshop Manual  
Full Download: <https://www.arepairmanual.com/downloads/2007-kawasaki-ninja-zx-6r-motocycle-service-repair-workshop-manual/>

Sample manual. Download All pages at:  
<https://www.arepairmanual.com/downloads/2007-kawasaki-ninja-zx-6r-motocycle-service-repair-workshop-manual/>

# Quick Reference Guide

|                                    |           |
|------------------------------------|-----------|
| <b>General Information</b>         | <b>1</b>  |
| <b>Periodic Maintenance</b>        | <b>2</b>  |
| <b>Fuel System (DFI)</b>           | <b>3</b>  |
| <b>Cooling System</b>              | <b>4</b>  |
| <b>Engine Top End</b>              | <b>5</b>  |
| <b>Clutch</b>                      | <b>6</b>  |
| <b>Engine Lubrication System</b>   | <b>7</b>  |
| <b>Engine Removal/Installation</b> | <b>8</b>  |
| <b>Crankshaft/Transmission</b>     | <b>9</b>  |
| <b>Wheels/Tires</b>                | <b>10</b> |
| <b>Final Drive</b>                 | <b>11</b> |
| <b>Brakes</b>                      | <b>12</b> |
| <b>Suspension</b>                  | <b>13</b> |
| <b>Steering</b>                    | <b>14</b> |
| <b>Frame</b>                       | <b>15</b> |
| <b>Electrical System</b>           | <b>16</b> |
| <b>Appendix</b>                    | <b>17</b> |

This quick reference guide will assist you in locating a desired topic or procedure.

- Bend the pages back to match the black tab of the desired chapter number with the black tab on the edge at each table of contents page.
- Refer to the sectional table of contents for the exact pages to locate the specific topic required.



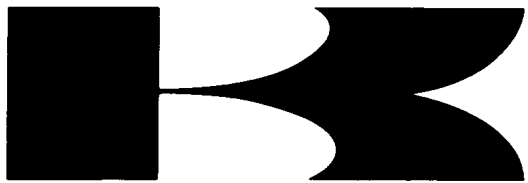

**Kawasaki**

**Ninja ZX-6R**

# **Motorcycle Service Manual**

---

All rights reserved. No parts of this publication may be reproduced, stored in a retrieval system, or transmitted in any form or by any means, electronic mechanical photocopying, recording or otherwise, without the prior written permission of Quality Assurance Division/Consumer Products & Machinery Company/Kawasaki Heavy Industries, Ltd., Japan.

No liability can be accepted for any inaccuracies or omissions in this publication, although every possible care has been taken to make it as complete and accurate as possible.

The right is reserved to make changes at any time without prior notice and without incurring an obligation to make such changes to products manufactured previously. See your Motorcycle dealer for the latest information on product improvements incorporated after this publication.

All information contained in this publication is based on the latest product information available at the time of publication. Illustrations and photographs in this publication are intended for reference use only and may not depict actual model component parts.

## LIST OF ABBREVIATIONS

|      |                           |     |                          |
|------|---------------------------|-----|--------------------------|
| A    | ampere(s)                 | lb  | pound(s)                 |
| ABDC | after bottom dead center  | m   | meter(s)                 |
| AC   | alternating current       | min | minute(s)                |
| ATDC | after top dead center     | N   | newton(s)                |
| BBDC | before bottom dead center | Pa  | pascal(s)                |
| BDC  | bottom dead center        | PS  | horsepower               |
| BTDC | before top dead center    | psi | pound(s) per square inch |
| °C   | degree(s) Celsius         | r   | revolution               |
| DC   | direct current            | rpm | revolution(s) per minute |
| F    | farad(s)                  | TDC | top dead center          |
| °F   | degree(s) Fahrenheit      | TIR | total indicator reading  |
| ft   | foot, feet                | V   | volt(s)                  |
| g    | gram(s)                   | W   | watt(s)                  |
| h    | hour(s)                   | Ω   | ohm(s)                   |
| L    | liter(s)                  |     |                          |

## COUNTRY AND AREA CODES

|     |            |      |                             |
|-----|------------|------|-----------------------------|
| AU  | Australia  | MY   | Malaysia                    |
| CA  | Canada     | US   | United States               |
| CAL | California | WVTA | Whole Vehicle Type Approval |
| FR  | France     |      |                             |

## EMISSION CONTROL INFORMATION

To protect the environment in which we all live, Kawasaki has incorporated crankcase emission (1) and exhaust emission (2) control systems in compliance with applicable regulations of the United States Environmental Protection Agency and California Air Resources Board. Additionally, Kawasaki has incorporated an evaporative emission control system (3) in compliance with applicable regulations of the California Air Resources Board on vehicles sold in California only.

### 1. Crankcase Emission Control System

This system eliminates the release of crankcase vapors into the atmosphere. Instead, the vapors are routed through an oil separator to the inlet side of the engine. While the engine is operating, the vapors are drawn into combustion chamber, where they are burned along with the fuel and air supplied by the fuel injection system.

### 2. Exhaust Emission Control System

This system reduces the amount of pollutants discharged into the atmosphere by the exhaust of this motorcycle. The fuel, ignition, and exhaust systems of this motorcycle have been carefully designed and constructed to ensure an efficient engine with low exhaust pollutant levels.

The exhaust system of this model motorcycle manufactured primarily for sale in California includes a catalytic converter system.

### 3. Evaporative Emission Control System

Vapors caused by fuel evaporation in the fuel system are not vented into the atmosphere. Instead, fuel vapors are routed into the running engine to be burned, or stored in a canister when the engine is stopped. Liquid fuel is caught by a vapor separator and returned to the fuel tank.

The Clean Air Act, which is the Federal law covering motor vehicle pollution, contains what is commonly referred to as the Act's "tampering provisions".

"Sec. 203(a) The following acts and the causing thereof are prohibited...

(3)(A) for any person to remove or render inoperative any device or element of design installed on or in a motor vehicle or motor vehicle engine in compliance with regulations under this title prior to its sale and delivery to the ultimate purchaser, or for any manufacturer or dealer knowingly to remove or render inoperative any such device or element of design after such sale and delivery to the ultimate purchaser.

(3)(B) for any person engaged in the business of repairing, servicing, selling, leasing, or trading motor vehicles or motor vehicle engines, or who operates a fleet of motor vehicles knowingly to remove or render inoperative any device or element of design installed on or in a motor vehicle or motor vehicle engine in compliance with regulations under this title following its sale and delivery to the ultimate purchaser..."

### NOTE

○The phrase "remove or render inoperative any device or element of design" has been generally interpreted as follows.

1. Tampering does not include the temporary removal or rendering inoperative of devices or elements of design in order to perform maintenance.
2. Tampering could include.
  - a. Maladjustment of vehicle components such that the emission standards are exceeded.
  - b. Use of replacement parts or accessories which adversely affect the performance or durability of the motorcycle.
  - c. Addition of components or accessories that result in the vehicle exceeding the standards.
  - d. Permanently removing, disconnecting, or rendering inoperative any component or element of design of the emission control systems.

**WE RECOMMEND THAT ALL DEALERS OBSERVE THESE PROVISIONS OF FEDERAL LAW, THE VIOLATION OF WHICH IS PUNISHABLE BY CIVIL PENALTIES NOT EXCEEDING \$10 000 PER VIOLATION.**

## **TAMPERING WITH NOISE CONTROL SYSTEM PROHIBITED**

Federal law prohibits the following acts or the causing thereof. (1) The removal or rendering inoperative by any person other than for purposes of maintenance, repair, or replacement, of any device or element of design incorporated into any new vehicle for the purpose of noise control prior to its sale or delivery to the ultimate purchaser or while it is in use, or (2) the use of the vehicle after such device or element of design has been removed or rendered inoperative by any person.

Among those acts presumed to constitute tampering are the acts listed below.

- Replacement of the original exhaust system or muffler with a component not in compliance with Federal regulations.
- Removal of the muffler(s) or any internal portion of the muffler(s).
- Removal of the air box or air box cover.
- Modifications to the muffler(s) or air inlet system by cutting, drilling, or other means if such modifications result in increased noise levels.

# Foreword

This manual is designed primarily for use by trained mechanics in a properly equipped shop. However, it contains enough detail and basic information to make it useful to the owner who desires to perform his own basic maintenance and repair work. A basic knowledge of mechanics, the proper use of tools, and workshop procedures must be understood in order to carry out maintenance and repair satisfactorily. Whenever the owner has insufficient experience or doubts his ability to do the work, all adjustments, maintenance, and repair should be carried out only by qualified mechanics.

In order to perform the work efficiently and to avoid costly mistakes, read the text, thoroughly familiarize yourself with the procedures before starting work, and then do the work carefully in a clean area. Whenever special tools or equipment are specified, do not use makeshift tools or equipment. Precision measurements can only be made if the proper instruments are used, and the use of substitute tools may adversely affect safe operation.

**For the duration of the warranty period,** we recommend that all repairs and scheduled maintenance be performed in accordance with this service manual. Any owner maintenance or repair procedure not performed in accordance with this manual may void the warranty.

To get the longest life out of your vehicle.

- Follow the Periodic Maintenance Chart in the Service Manual.
- Be alert for problems and non-scheduled maintenance.
- Use proper tools and genuine Kawasaki Motorcycle parts. Special tools, gauges, and testers that are necessary when servicing Kawasaki motorcycles are introduced by the Service Manual. Genuine parts provided as spare parts are listed in the Parts Catalog.
- Follow the procedures in this manual carefully. Don't take shortcuts.
- Remember to keep complete records of maintenance and repair with dates and any new parts installed.

---

## How to Use This Manual

---

In this manual, the product is divided into its major systems and these systems make up the manual's chapters. The Quick Reference

Guide shows you all of the product's system and assists in locating their chapters. Each chapter in turn has its own comprehensive Table of Contents.

For example, if you want stick coil information, use the Quick Reference Guide to locate the Electrical System chapter. Then, use the Table of Contents on the first page of the chapter to find the Stick Coil section.

Whenever you see these WARNING and CAUTION symbols, heed their instructions! Always follow safe operating and maintenance practices.

### WARNING

**This warning symbol identifies special instructions or procedures which, if not correctly followed, could result in personal injury, or loss of life.**

### CAUTION

**This caution symbol identifies special instructions or procedures which, if not strictly observed, could result in damage to or destruction of equipment.**

This manual contains four more symbols (in addition to WARNING and CAUTION) which will help you distinguish different types of information.

### NOTE

○ *This note symbol indicates points of particular interest for more efficient and convenient operation.*

- Indicates a procedural step or work to be done.
- Indicates a procedural sub-step or how to do the work of the procedural step it follows. It also precedes the text of a NOTE.
- ★ Indicates a conditional step or what action to take based on the results of the test or inspection in the procedural step or sub-step it follows.

In most chapters an exploded view illustration of the system components follows the Table of Contents. In these illustrations you will find the instructions indicating which parts require specified tightening torque, oil, grease or a locking agent during assembly.



# General Information

## Table of Contents

|                             |      |
|-----------------------------|------|
| Before Servicing .....      | 1-2  |
| Model Identification.....   | 1-7  |
| General Specifications..... | 1-9  |
| Unit Conversion Table ..... | 1-12 |

## 1-2 GENERAL INFORMATION

### Before Servicing

Before starting to perform an inspection service or carry out a disassembly and reassembly operation on a motorcycle, read the precautions given below. To facilitate actual operations, notes, illustrations, photographs, cautions, and detailed descriptions have been included in each chapter wherever necessary. This section explains the items that require particular attention during the removal and reinstallation or disassembly and reassembly of general parts.

Especially note the following.

#### **Battery Ground**

Before completing any service on the motorcycle, disconnect the battery cables from the battery to prevent the engine from accidentally turning over. Disconnect the ground cable (-) first and then the positive (+). When completed with the service, first connect the positive (+) cable to the positive (+) terminal of the battery then the negative (-) cable to the negative terminal.

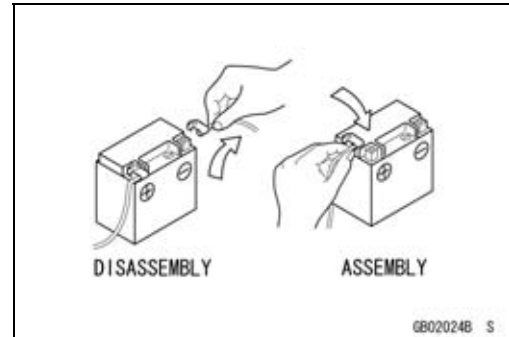

#### **Edges of Parts**

Lift large or heavy parts wearing gloves to prevent injury from possible sharp edges on the parts.

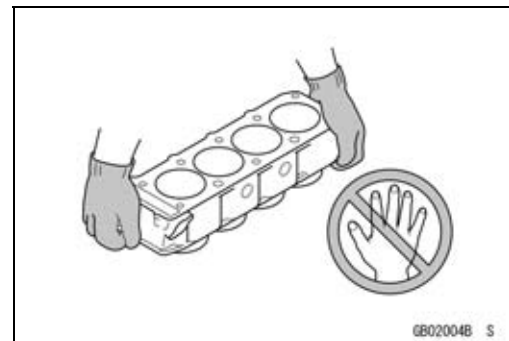

#### **Solvent**

Use a high-flash point solvent when cleaning parts. High-flash point solvent should be used according to directions of the solvent manufacturer.

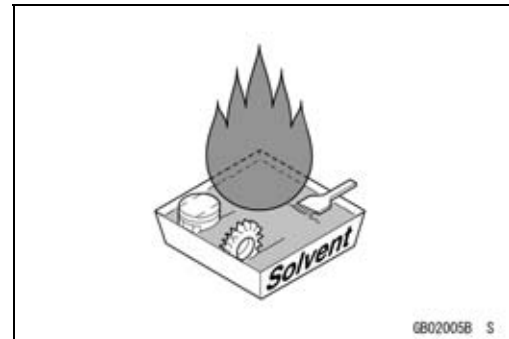

#### **Cleaning vehicle before disassembly**

Clean the vehicle thoroughly before disassembly. Dirt or other foreign materials entering into sealed areas during vehicle disassembly can cause excessive wear and decrease performance of the vehicle.

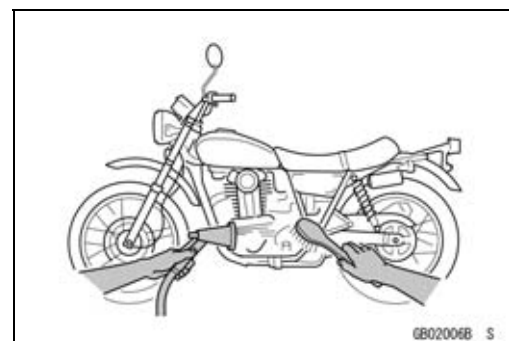

## Before Servicing

### **Arrangement and Cleaning of Removed Parts**

Disassembled parts are easy to confuse. Arrange the parts according to the order the parts were disassembled and clean the parts in order prior to assembly.

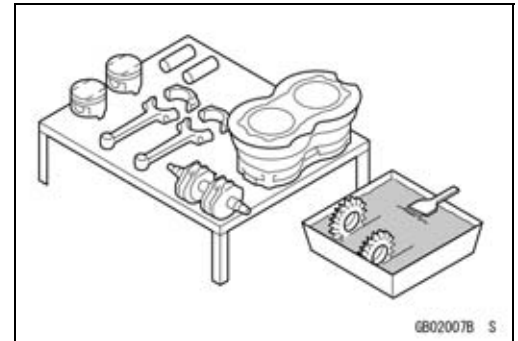

### **Storage of Removed Parts**

After all the parts including subassembly parts have been cleaned, store the parts in a clean area. Put a clean cloth or plastic sheet over the parts to protect from any foreign materials that may collect before re-assembly.

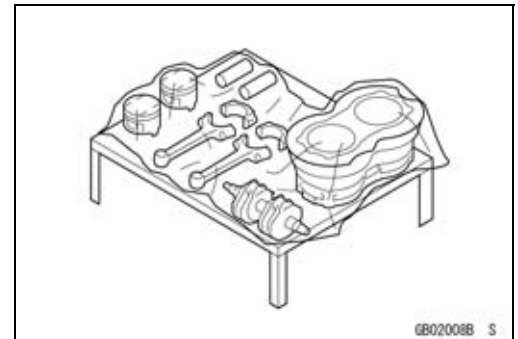

### **Inspection**

Reuse of worn or damaged parts may lead to serious accident. Visually inspect removed parts for corrosion, discoloration, or other damage. Refer to the appropriate sections of this manual for service limits on individual parts. Replace the parts if any damage has been found or if the part is beyond its service limit.

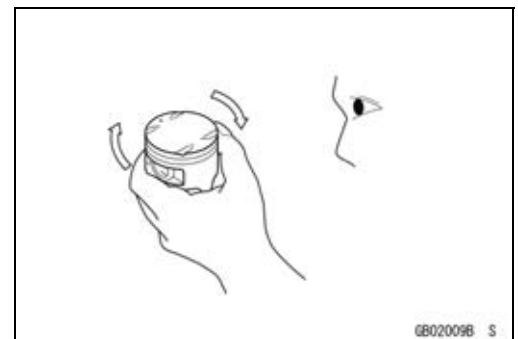

### **Replacement Parts**

Replacement Parts must be KAWASAKI genuine or recommended by KAWASAKI. Gaskets, O-rings, oil seals, grease seals, circlips or cotter pins must be replaced with new ones whenever disassembled.

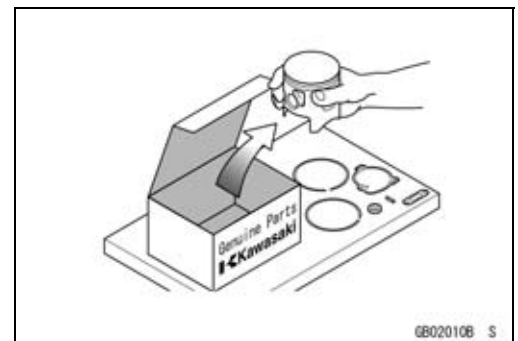

### **Assembly Order**

In most cases assembly order is the reverse of disassembly, however, if assembly order is provided in this Service Manual, follow the procedures given.

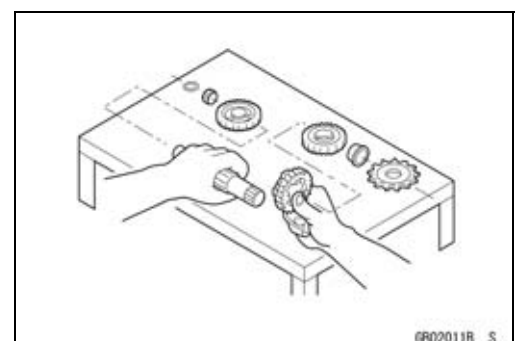

## 1-4 GENERAL INFORMATION

### Before Servicing

#### **Tightening Sequence**

Generally, when installing a part with several bolts, nuts, or screws, start them all in their holes and tighten them to a snug fit. Then tighten them according to the specified sequence to prevent case warpage or deformation which can lead to malfunction. Conversely when loosening the bolts, nuts, or screws, first loosen all of them by about a quarter turn and then remove them. If the specified tightening sequence is not indicated, tighten the fasteners alternating diagonally.

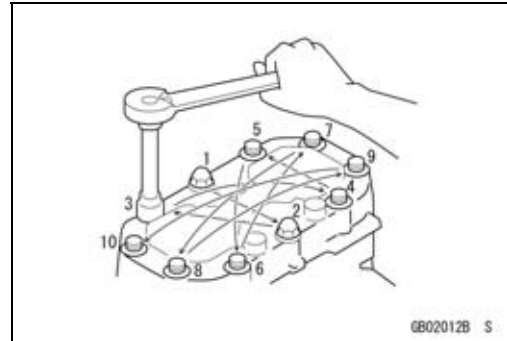

#### **Tightening Torque**

Incorrect torque applied to a bolt, nut, or screw may lead to serious damage. Tighten fasteners to the specified torque using a good quality torque wrench.

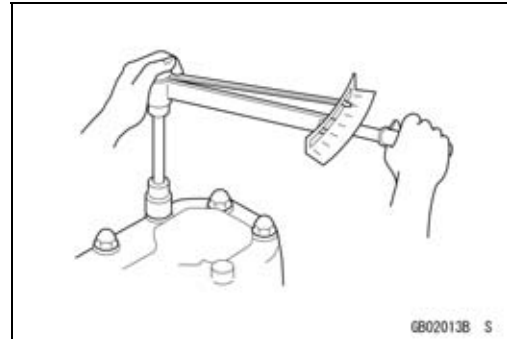

#### **Force**

Use common sense during disassembly and assembly, excessive force can cause expensive or hard to repair damage. When necessary, remove screws that have a non-permanent locking agent applied using an impact driver. Use a plastic-faced mallet whenever tapping is necessary.

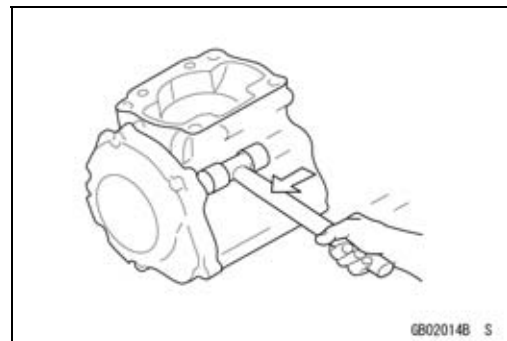

#### **Gasket, O-ring**

Hardening, shrinkage, or damage of both gaskets and O-rings after disassembly can reduce sealing performance. Remove the old gaskets and clean the sealing surfaces thoroughly so that no gasket material or other material remains. Install the new gaskets and replace the used O-rings when re-assembling.

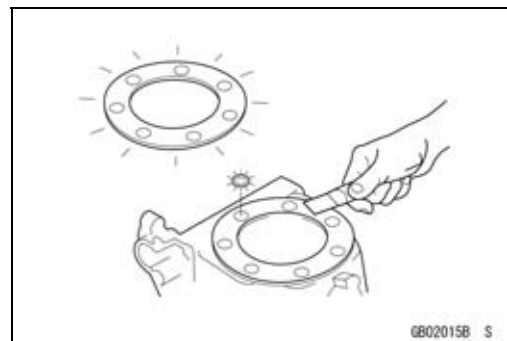

#### **Liquid Gasket, Non-permanent Locking Agent**

For applications that require Liquid Gasket or a Non-permanent Locking Agent, clean the surfaces so that no oil residue remains before applying liquid gasket or non-permanent locking agent. Do not apply them excessively. Excessive application can clog oil passages and cause serious damage.



**Before Servicing**

**Press**

For items such as bearings or oil seals that must be pressed into place, apply small amount of oil to the contact area. Be sure to maintain proper alignment and use smooth movements when installing.

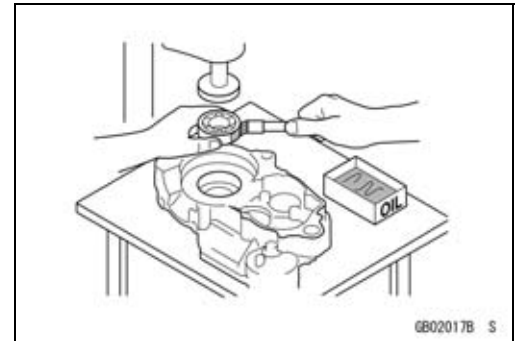

**Ball Bearing and Needle Bearing**

Do not remove pressed ball or needle unless removal is absolutely necessary. Replace with new ones whenever removed. Press bearings with the manufacturer and size marks facing out. Press the bearing into place by putting pressure on the correct bearing race as shown.

Pressing the incorrect race can cause pressure between the inner and outer race and result in bearing damage.

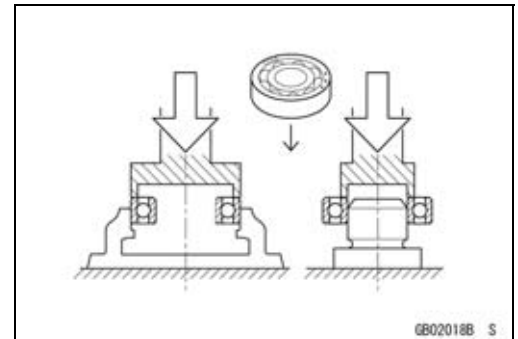

**Oil Seal, Grease Seal**

Do not remove pressed oil or grease seals unless removal is necessary. Replace with new ones whenever removed. Press new oil seals with manufacture and size marks facing out. Make sure the seal is aligned properly when installing.

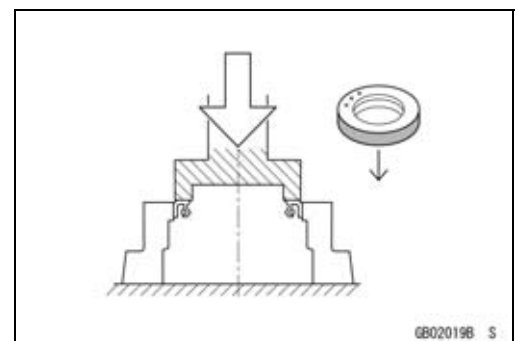

Apply specified grease to the lip of seal before installing the seal.

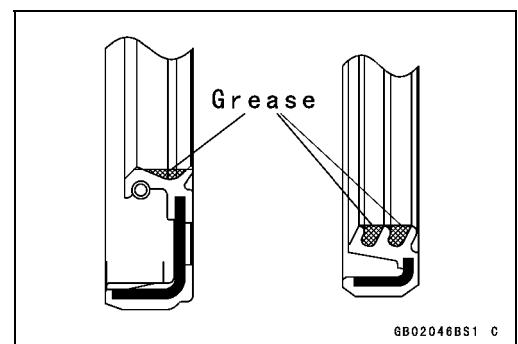

**Circlips, Cotter Pins**

Replace the circlips or cotter pins that were removed with new ones. Take care not to open the clip excessively when installing to prevent deformation.

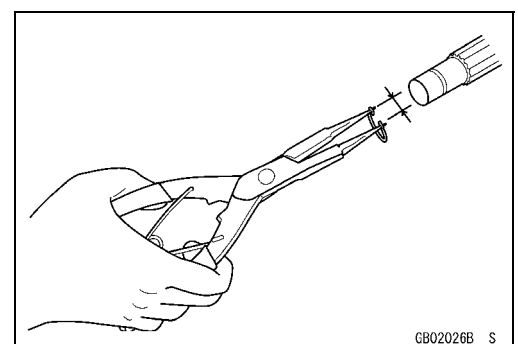

# 1-6 GENERAL INFORMATION

## Before Servicing

### **Lubrication**

It is important to lubricate rotating or sliding parts during assembly to minimize wear during initial operation. Lubrication points are called out throughout this manual, apply the specific oil or grease as specified.

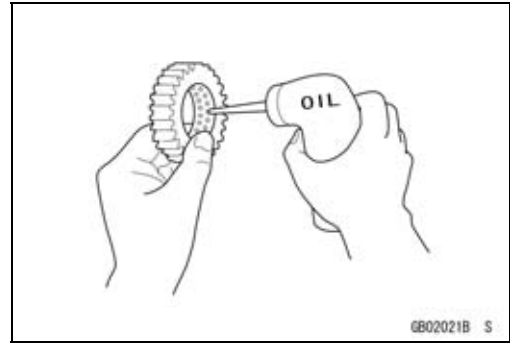

### **Direction of Engine Rotation**

When rotating the crankshaft by hand, the free play amount of rotating direction will affect the adjustment. Rotate the crankshaft to positive direction (clockwise viewed from output side).

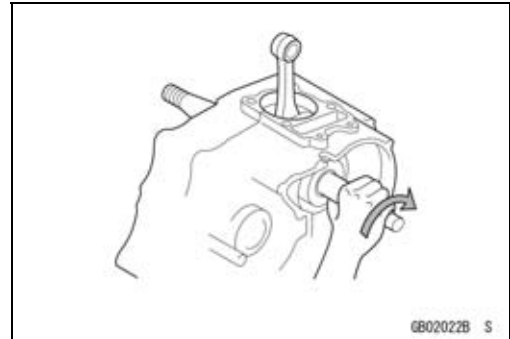

### **Electrical Wires**

A two-color wire is identified first by the primary color and then the stripe color. Unless instructed otherwise, electrical wires must be connected to those of the same color.

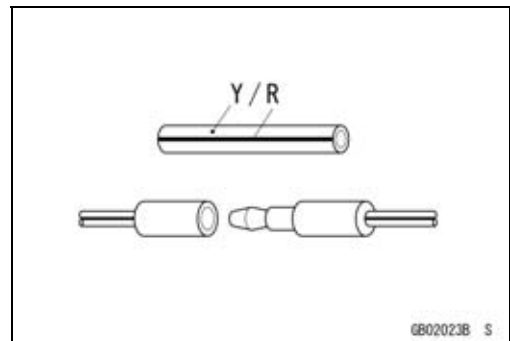

### **Instrument**

Use a meter that has enough accuracy for an accurate measurement. Read the manufacture's instructions thoroughly before using the meter. Incorrect values may lead to improper adjustments.

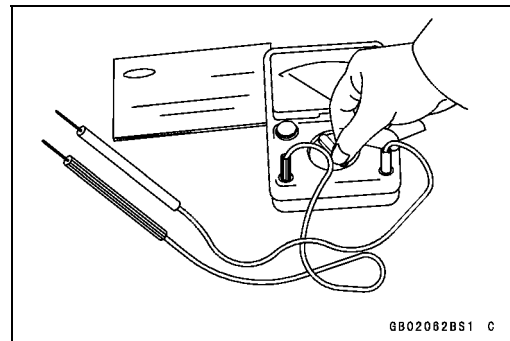

Model Identification

ZX600P7F (Europe) Left Side View



ZX600P7F (Europe) Right Side View



## 1-8 GENERAL INFORMATION

### Model Identification

#### ZX600P7F (US and Canada) Left Side View



#### ZX600P7F (US and Canada) Right Side View



**General Specifications**

| Items                     | ZX600P7F (Ninja ZX-6R)  |
|---------------------------|---|
| <b>Dimensions</b>         |   |
| Overall Length            | 2 105 mm (82.9 in.)   |
| Overall Width             | 720 mm (28.3 in.)   |
| Overall Height            | 1 125 mm (44.3 in.)   |
| Wheelbase                 | 1 405 mm (55.3 in.)   |
| Road Clearance            | 125 mm (4.7 in.)  |
| Seat Height               | 820 mm (32.3 in.)   |
| Dry Mass                  | 167 kg (368 lb)   |
| Curb Mass:                |   |
| Front                     | 101 kg (223 lb)   |
| Rear                      | 99 kg (218 lb)  |
| Fuel Tank Capacity        | 17 L (4.5 US gal)   |
| <b>Performance</b>        |   |
| Minimum Turning Radius    | 3.4 m (11.2 ft)   |
| <b>Engine</b>             |   |
| Type                      | 4-stroke, DOHC, 4-cylinder  |
| Cooling System            | Liquid-cooled   |
| Bore and Stroke           | 67.0 × 42.5 mm (2.6 × 1.7 in.)  |
| Displacement              | 599 mL (36.6 cu in.)  |
| Compression Ratio         | 13.3 : 1  |
| Maximum Horsepower        | 91.9 kW (125 PS) @14 000 r/min (rpm),<br>(FR) 78.2 kW (106 PS) @14 000 r/min (rpm),<br>(MY) 80.0 kW (109 PS) @12 000 r/min (rpm),<br>(CA), (CAL), (US) — — —  |
| Maximum Torque            | 66.0 N·m (6.7 kgf·m, 49 ft·lb) @11 700 r/min (rpm),<br>(FR) 58.4 N·m (6.0 kgf·m, 43 ft·lb) @11 700 r/min (rpm),<br>(MY) 64 N·m (6.5 kgf·m, 47 ft·lb) @12 000 r/min (rpm)<br>(CA), (CAL), (US) — — — |
| Carburetion System        | FI (Fuel injection)<br>Primary: KEIHIN TTK 38 × 4<br>Secondary: KEIHIN Multihole (8 holes) × 4  |
| Starting System           | Electric starter  |
| Ignition System           | Battery and coil (transistorized)   |
| Timing Advance            | Electronically advanced (digital igniter in ECU)  |
| Ignition Timing           | From 12.5° BTDC @1 300 r/min (rpm)  |
| Spark Plug                | NGK CR9E  |
| Cylinder Numbering Method | Left to right, 1-2-3-4  |
| Firing Order              | 1-2-4-3   |
| Valve Timing:             |   |
| Inlet:                    |   |
| Open                      | 41° BTDC  |
| Close                     | 67° ATDC  |
| Duration                  | 288°  |
| Exhaust:                  |   |
| Open                      | 63° BBDC  |
| Close                     | 23° ATDC  |

# 1-10 GENERAL INFORMATION

## General Specifications

| Items   | ZX600P7F (Ninja ZX-6R)  |
|---|---|
| Duration<br>Lubrication System<br>Engine Oil:<br>Type<br>Viscosity<br>Capacity  | 266°<br>Forced lubrication (wet sump with cooler)<br>API SE, SF or SG<br>API SH, SJ or SL with JASO MA<br>SAE10W-40<br>3.8 L (4.0 US qt)  |
| <b>Drive Train</b><br>Primary Reduction System:<br>Type<br>Reduction Ratio<br>Clutch Type<br>Transmission:<br>Type<br>Gear Ratios:<br>1st<br>2nd<br>3rd<br>4th<br>5th<br>6th<br>Final Drive System:<br>Type<br>Reduction Ratio<br>Overall Drive Ratio | Gear<br>1.900 (76/40)<br>Wet multi disc<br>6-speed, constant mesh, return shift<br>2.714 (38/14)<br>2.200 (33/15)<br>1.850 (37/20)<br>1.600 (32/20)<br>1.421 (27/19)<br>1.300 (26/20)<br>Chain drive<br>2.688 (43/16)<br>6.638 @Top gear          |
| <b>Frame</b><br>Type<br>Caster (Rake Angle)<br>Trail<br>Front Tire:<br>Type<br>Size<br>Rear Tire:<br>Type<br>Size<br>Rim Size:<br>Front<br>Rear<br>Front Suspension:<br>Type<br>Wheel Travel<br>Rear Suspension:<br>Type<br>Wheel Travel              | Tubular, diamond<br>25°<br>110 mm (4.3 in.)<br>Tubeless<br>120/70 ZR17 M/C (58 W)<br>Tubeless<br>180/55 ZR17 M/C (73 W)<br>17 × 3.50<br>17 × 5.50<br>Telescopic fork (upside-down)<br>120 mm (4.7 in.)<br>Swingarm (uni-trak)<br>133 mm (5.2 in.) |

---

**General Specifications**

---

| Items   | ZX600P7F (Ninja ZX-6R)   |
|---|--|
| Brake Type:<br>Front<br>Rear  | Dual discs<br>Single disc  |
| <b>Electrical Equipment</b><br>Battery<br>Headlight:<br>Type<br>Bulb:<br>High<br>Low<br>Tail/Brake Light<br>Alternator:<br>Type<br>Rated Output | 12 V 8 Ah<br>Semi-sealed beam<br>12 V 55 W + 65 W (quartz-halogen)<br>12 V 55 W (quartz-halogen)<br>12 V 0.1/1.6 W (LED)<br>Three-phase AC<br>31 A/14 V @5 000 r/min (rpm) |

Specifications subject to change without notice, and may not apply to every country.

# 1-12 GENERAL INFORMATION

## Unit Conversion Table

### Prefixes for Units

| Prefix | Symbol | Power       |
|--------|--------|-------------|
| mega   | M      | × 1 000 000 |
| kilo   | k      | × 1 000     |
| centi  | c      | × 0.01      |
| milli  | m      | × 0.001     |
| micro  | μ      | × 0.000001  |

### Units of Mass

|    |   |         |   |    |
|----|---|---------|---|----|
| kg | × | 2.205   | = | lb |
| g  | × | 0.03527 | = | oz |

### Units of Volume

|    |   |         |   |            |
|----|---|---------|---|------------|
| L  | × | 0.2642  | = | gal (US)   |
| L  | × | 0.2200  | = | gal (imp)  |
| L  | × | 1.057   | = | qt (US)    |
| L  | × | 0.8799  | = | qt (imp)   |
| L  | × | 2.113   | = | pint (US)  |
| L  | × | 1.816   | = | pint (imp) |
| mL | × | 0.03381 | = | oz (US)    |
| mL | × | 0.02816 | = | oz (imp)   |
| mL | × | 0.06102 | = | cu in      |

### Units of Force

|    |   |        |   |    |
|----|---|--------|---|----|
| N  | × | 0.1020 | = | kg |
| N  | × | 0.2248 | = | lb |
| kg | × | 9.807  | = | N  |
| kg | × | 2.205  | = | lb |

### Units of Length

|    |   |         |   |      |
|----|---|---------|---|------|
| km | × | 0.6214  | = | mile |
| m  | × | 3.281   | = | ft   |
| mm | × | 0.03937 | = | in   |

### Units of Torque

|       |   |        |   |       |
|-------|---|--------|---|-------|
| N·m   | × | 0.1020 | = | kgf·m |
| N·m   | × | 0.7376 | = | ft·lb |
| N·m   | × | 8.851  | = | in·lb |
| kgf·m | × | 9.807  | = | N·m   |
| kgf·m | × | 7.233  | = | ft·lb |
| kgf·m | × | 86.80  | = | in·lb |

### Units of Pressure

|                     |   |         |   |                     |
|---------------------|---|---------|---|---------------------|
| kPa                 | × | 0.01020 | = | kgf/cm <sup>2</sup> |
| kPa                 | × | 0.1450  | = | psi                 |
| kPa                 | × | 0.7501  | = | cmHg                |
| kgf/cm <sup>2</sup> | × | 98.07   | = | kPa                 |
| kgf/cm <sup>2</sup> | × | 14.22   | = | psi                 |
| cmHg                | × | 1.333   | = | kPa                 |

### Units of Speed

|      |   |        |   |     |
|------|---|--------|---|-----|
| km/h | × | 0.6214 | = | mph |
|------|---|--------|---|-----|

### Units of Power

|    |   |        |   |    |
|----|---|--------|---|----|
| kW | × | 1.360  | = | PS |
| kW | × | 1.341  | = | HP |
| PS | × | 0.7355 | = | kW |
| PS | × | 0.9863 | = | HP |

### Units of Temperature

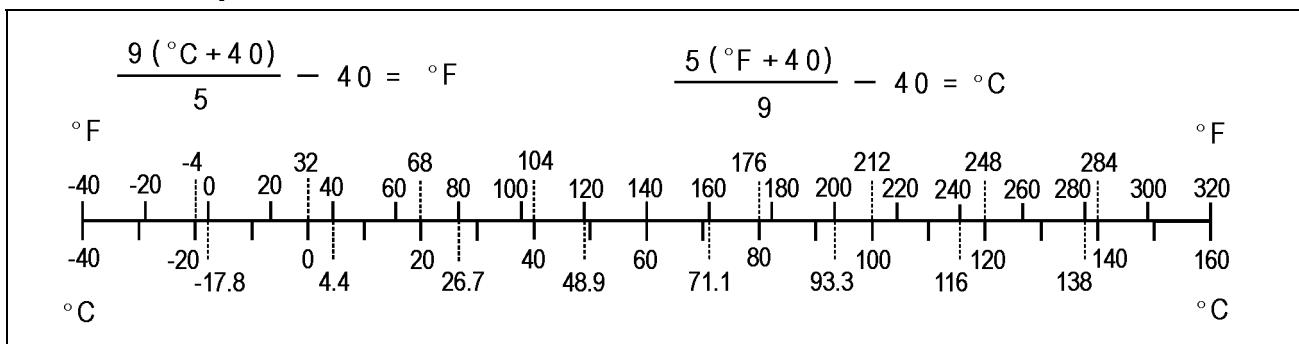

# Periodic Maintenance

## Table of Contents

|   |      |
|---|------|
| Periodic Maintenance Chart .....                                      | 2-3  |
| Torque and Locking Agent.....   | 2-6  |
| Specifications .....  | 2-12 |
| Special Tools .....   | 2-14 |
| Maintenance Procedure .....   | 2-15 |
| Fuel System (DFI).....  | 2-15 |
| Throttle Control System Inspection.....                               | 2-15 |
| Engine Vacuum Synchronization Inspection.....                         | 2-15 |
| Idle Speed Inspection .....   | 2-18 |
| Idle Speed Adjustment.....  | 2-19 |
| Fuel Hose Inspection (fuel leak, damage, installation condition)..... | 2-19 |
| Evaporative Emission Control System (California Model) .....          | 2-19 |
| Evaporative Emission Control System Inspection .....                  | 2-19 |
| Engine Top End .....  | 2-20 |
| Valve Clearance Inspection .....                                      | 2-20 |
| Valve Clearance Adjustment.....                                       | 2-22 |
| Air Suction System .....  | 2-24 |
| Air Suction System Damage Inspection.....                             | 2-24 |
| Cooling System.....   | 2-25 |
| Coolant Level Inspection.....   | 2-25 |
| Radiator Hose Damage and Installation Condition Inspection.....       | 2-25 |
| Clutch.....   | 2-26 |
| Clutch Operation Inspection .....                                     | 2-26 |
| Wheels/Tires .....  | 2-27 |
| Air Pressure Inspection.....  | 2-27 |
| Wheel/Tire Damage Inspection.....                                     | 2-27 |
| Tire Tread Wear Inspection .....                                      | 2-27 |
| Wheel Bearing Damage Inspection .....                                 | 2-28 |
| Drive Train .....   | 2-29 |
| Drive Chain Lubrication Condition Inspection .....                    | 2-29 |
| Drive Chain Slack Inspection .....                                    | 2-29 |
| Drive Chain Slack Adjustment .....                                    | 2-30 |
| Wheel Alignment Inspection .....                                      | 2-31 |
| Drive Chain Wear Inspection .....                                     | 2-31 |
| Chain Guide Wear Inspection .....                                     | 2-32 |
| Brake System .....  | 2-32 |
| Brake Fluid Leak (Brake Hose and Pipe) Inspection .....               | 2-32 |
| Brake Hose Damage and Installation Condition Inspection.....          | 2-32 |
| Brake Operation Inspection .....                                      | 2-33 |
| Brake Fluid Level Inspection.....                                     | 2-33 |
| Brake Pad Wear Inspection .....                                       | 2-34 |
| Brake Light Switch Operation Inspection .....                         | 2-34 |
| Suspensions .....   | 2-35 |
| Front Forks/Rear Shock Absorber Operation Inspection .....            | 2-35 |
| Front Fork Oil Leak Inspection.....                                   | 2-35 |
| Rear Shock Absorber Oil Leak Inspection .....                         | 2-36 |
| Rocker Arm Operation Inspection.....                                  | 2-36 |
| Tie-Rod Operation Inspection .....                                    | 2-36 |
| Steering System .....   | 2-36 |
| Steering Play Inspection .....  | 2-36 |

## 2-2 PERIODIC MAINTENANCE

---

|   |      |
|---|------|
| Steering Play Adjustment.....                       | 2-37 |
| Steering Stem Bearing Lubrication .....             | 2-38 |
| Lights and Switches Operation Inspection.....       | 2-38 |
| Headlight Aiming Inspection .....                   | 2-40 |
| Side Stand Switch Operation Inspection.....         | 2-41 |
| Engine Stop Switch Operation Inspection.....        | 2-42 |
| Others.....   | 2-43 |
| Chassis Parts Lubrication .....                     | 2-43 |
| Bolts, Nuts and Fasteners Tightness Inspection..... | 2-44 |
| Replacement Parts .....                             | 2-46 |
| Air Cleaner Element Replacement.....                | 2-46 |
| Fuel Hose Replacement .....                         | 2-47 |
| Coolant Change.....                                 | 2-50 |
| Radiator Hose and O-ring Replacement.....           | 2-52 |
| Engine Oil Change.....                              | 2-53 |
| Oil Filter Replacement .....                        | 2-53 |
| Brake Hose and Pipe Replacement.....                | 2-54 |
| Brake Fluid Change .....                            | 2-54 |
| Master Cylinder Rubber Parts Replacement .....      | 2-56 |
| Caliper Rubber Parts Replacement .....              | 2-57 |
| Spark Plug Replacement .....                        | 2-60 |

**Periodic Maintenance Chart**

The scheduled maintenance must be done in accordance with this chart to keep the motorcycle in good running condition. **The initial maintenance is vitally important and must not be neglected.**

**Periodic Inspection**

| INSPECTION   | FREQUENCY                           | * ODOMETER READING<br>× 1 000 km<br>(× 1 000 mile) |          |             |            |            |            |            |
|--|-------------------------------------|--|----------|-------------|------------|------------|------------|------------|
|  | Whichever comes first<br>↓<br>Every | 1<br>(0.6)   | 6<br>(4) | 12<br>(7.5) | 18<br>(12) | 24<br>(15) | 30<br>(20) | 36<br>(24) |
| <b>Fuel System</b>   |                                     |  |          |             |            |            |            |            |
| Throttle control system (play, smooth return, no drag)-inspect       | year                                | •  |          | •           |            | •          |            | •          |
| Engine vacuum synchronization-inspect                                |                                     |  |          | •           |            | •          |            | •          |
| Idle speed-inspect   |                                     | •  |          | •           |            | •          |            | •          |
| Fuel leak (fuel hose and pipe)-inspect                               | year                                | •  |          | •           |            | •          |            | •          |
| Fuel hose and pipe damage-inspect                                    | year                                | •  |          | •           |            | •          |            | •          |
| Fuel hose and pipe installation condition-inspect                    | year                                | •  |          | •           |            | •          |            | •          |
| <b>Evaporative Emission Control System (California Model only)</b>   |                                     |  |          |             |            |            |            |            |
| Evaporative emission control system function-inspect                 |                                     | •  | •        | •           | •          | •          | •          | •          |
| <b>Cooling System</b>  |                                     |  |          |             |            |            |            |            |
| Coolant level-inspect  |                                     | •  |          | •           |            | •          |            | •          |
| Coolant leak (radiator hose and pipe)-inspect                        | year                                | •  |          | •           |            | •          |            | •          |
| Radiator hose damage-inspect   | year                                | •  |          | •           |            | •          |            | •          |
| Radiator hose installation condition -inspect                        | year                                | •  |          | •           |            | •          |            | •          |
| <b>Engine Top End</b>  |                                     |  |          |             |            |            |            |            |
| Valve clearance-inspect (United States and Canada Models)            |                                     |  |          |             |            | •          |            |            |
| Valve clearance-inspect (Other than United States and Canada Models) |                                     | Every 42 000 km (26 000 mile)                      |          |             |            |            |            |            |
| <b>Air Suction System</b>  |                                     |  |          |             |            |            |            |            |
| Air suction system damage-inspect                                    |                                     |  |          | •           |            | •          |            | •          |
| <b>Clutch</b>  |                                     |  |          |             |            |            |            |            |
| Clutch operation (play, disengagement, engagement)-inspect           |                                     | •  |          | •           |            | •          |            | •          |
| <b>Wheels and Tires</b>  |                                     |  |          |             |            |            |            |            |
| Tire air pressure-inspect  | year                                |  |          | •           |            | •          |            | •          |
| Wheel/tire damage-inspect  |                                     |  |          | •           |            | •          |            | •          |
| Tire tread wear, abnormal wear-inspect                               |                                     |  |          | •           |            | •          |            | •          |
| Wheel bearing damage-inspect   | year                                |  |          | •           |            | •          |            | •          |
| <b>Drive Train</b>   |                                     |  |          |             |            |            |            |            |
| Drive chain lubrication condition-inspect #                          |                                     | Every 600 km (400 mile)                            |          |             |            |            |            |            |
| Drive chain slack-inspect #  |                                     | Every 1 000 km (600 mile)                          |          |             |            |            |            |            |

## 2-4 PERIODIC MAINTENANCE

### Periodic Maintenance Chart

| FREQUENCY   | Whichever comes first<br>↓ | * ODOMETER READING<br>× 1 000 km<br>(× 1 000 mile) |          |             |            |            |            |            |
|---|----------------------------|--|----------|-------------|------------|------------|------------|------------|
|   |                            | 1<br>(0.6)   | 6<br>(4) | 12<br>(7.5) | 18<br>(12) | 24<br>(15) | 30<br>(20) | 36<br>(24) |
| INSPECTION  | Every                      |  |          |             |            |            |            |            |
| Drive chain wear-inspect #  |                            |  |          | •           |            | •          |            | •          |
| Drive chain guide wear-inspect  |                            |  |          | •           |            | •          |            | •          |
| <b>Brake System</b>   |                            |  |          |             |            |            |            |            |
| Brake fluid leak (brake hose and pipe)-inspect                                | year                       | •  | •        | •           | •          | •          | •          | •          |
| Brake hose and pipe damage-inspect  | year                       | •  | •        | •           | •          | •          | •          | •          |
| Brake pad wear-inspect #  |                            |  | •        | •           | •          | •          | •          | •          |
| Brake hose installation condition-inspect                                     | year                       | •  | •        | •           | •          | •          | •          | •          |
| Brake fluid level-inspect   | 6 months                   | •  | •        | •           | •          | •          | •          | •          |
| Brake operation (effectiveness, play, no drag)-inspect                        | year                       | •  | •        | •           | •          | •          | •          | •          |
| Brake light switch operation-inspect  |                            | •  | •        | •           | •          | •          | •          | •          |
| <b>Suspensions</b>  |                            |  |          |             |            |            |            |            |
| Front forks/rear shock absorber operation (damping and smooth stroke)-inspect |                            |  |          | •           |            | •          |            | •          |
| Front forks/rear shock absorber oil leak-inspect                              | year                       |  |          | •           |            | •          |            | •          |
| Rocker arm operation-inspect  |                            |  |          | •           |            | •          |            | •          |
| Tie-Rods operation-inspect  |                            |  |          | •           |            | •          |            | •          |
| <b>Steering System</b>  |                            |  |          |             |            |            |            |            |
| Steering play-inspect   | year                       | •  |          | •           |            | •          |            | •          |
| Steering stem bearings-lubricate  | 2 years                    |  |          |             |            | •          |            |            |
| <b>Electrical System</b>  |                            |  |          |             |            |            |            |            |
| Lights and switches operation-inspect   | year                       |  |          | •           |            | •          |            | •          |
| Headlight aiming-inspect  | year                       |  |          | •           |            | •          |            | •          |
| Side stand switch operation-inspect   | year                       |  |          | •           |            | •          |            | •          |
| Engine stop switch operation-inspect  | year                       |  |          | •           |            | •          |            | •          |
| <b>Others</b>   |                            |  |          |             |            |            |            |            |
| Chassis parts-lubricate   | year                       |  |          | •           |            | •          |            | •          |
| Bolts and nuts tightness-inspect  |                            | •  |          | •           |            | •          |            | •          |

\*: For higher odometer readings, repeat at the frequency interval established here.

#: Service more frequently when operating in severe conditions; dusty, wet, muddy, high speed or frequent starting/stopping.

CAL: California Model

## PERIODIC MAINTENANCE 2-5

### Periodic Maintenance Chart

#### Periodic Replacement Parts

| CHANGE/REPLACE ITEM                         | FREQUENCY                          | * ODOMETER READING |             |            |            |            |
|---|------------------------------------|--------------------|-------------|------------|------------|------------|
|   | Whichever come first<br>↓<br>Every | 1<br>(0.6)         | 12<br>(7.5) | 24<br>(15) | 36<br>(24) | 48<br>(30) |
| Air cleaner element #                       | Every 18 000 km (12 000 mile)      |                    |             |            |            |            |
| Fuel hose                                   | 4 years                            |                    |             |            |            | •          |
| Coolant                                     | 3 years                            |                    |             |            | •          |            |
| Radiator hose and O-ring                    | 3 years                            |                    |             |            | •          |            |
| Engine oil #                                | year                               | •                  | •           | •          | •          | •          |
| Oil filter                                  | year                               | •                  | •           | •          | •          | •          |
| Brake hose and pipe                         | 4 years                            |                    |             |            |            | •          |
| Brake fluid                                 | 2 years                            |                    |             | •          |            | •          |
| Rubber parts of master cylinder and caliper | 4 years                            |                    |             |            |            | •          |
| Spark plug                                  |                                    |                    | •           | •          | •          | •          |

\*: For higher odometer readings, repeat at the frequency interval established here.

#: Service more frequently when operating in severe conditions; dusty, wet, muddy, high speed or frequent starting/stopping.

## 2-6 PERIODIC MAINTENANCE

### Torque and Locking Agent

The following tables list the tightening torque for the major fasteners requiring use of a non-permanent locking agent or silicone sealant etc.

Letters used in the "Remarks" column mean:

AL: Tighten the two clamp bolts alternately two times to ensure even tightening torque.

G: Apply grease to the threads.

L: Apply a non-permanent locking agent to the threads.

MO: Apply molybdenum disulfide grease oil solution.

R: Replacement Parts

S: Follow the specified tightening sequence.

Sl: Apply silicone grease.

SS: Apply silicone sealant.

| Fastener  | Torque |       |           | Remarks |
|---|--------|-------|-----------|---------|
|   | N·m    | kgf·m | ft·lb     |         |
| <b>Fuel System</b>                              |        |       |           |         |
| Air Cleaner Housing Screws                      | 1.1    | 0.11  | 9.7 in·lb |         |
| Air Cleaner Housing Clamp Bolts                 | 2.0    | 0.20  | 17 in·lb  |         |
| Air Cleaner Housing Mounting Bolt               | 6.9    | 0.70  | 61 in·lb  |         |
| Air Inlet Duct Mounting Bolts                   | 9.8    | 1.0   | 87 in·lb  | L       |
| Camshaft Position Sensor Bolt                   | 9.8    | 1.0   | 87 in·lb  |         |
| Crankshaft Sensor Bolts                         | 5.9    | 0.60  | 52 in·lb  |         |
| Delivery Pipe Mounting Screws (Nozzle Assy)     | 3.4    | 0.35  | 30 in·lb  |         |
| Delivery Pipe Mounting Screws (Throttle Body)   | 3.4    | 0.35  | 30 in·lb  |         |
| Exhaust Butterfly Valve Actuator Mounting Bolts | 6.9    | 0.70  | 61 in·lb  |         |
| Exhaust Butterfly Valve Actuator Pulley Bolt    | 4.9    | 0.50  | 43 in·lb  |         |
| Fuel Pump Bolts                                 | 9.8    | 1.0   | 87 in·lb  | L, S    |
| Nozzle Assy Mounting Bolts                      | 6.9    | 0.70  | 61 in·lb  |         |
| Nozzle Assy Fuel Hose Screw                     | 4.9    | 0.50  | 43 in·lb  |         |
| Separator Bracket Mounting Bolt                 | 0.8    | 0.08  | 7 in·lb   |         |
| Throttle Body Assembly Holder Clamp Bolts       | 3.0    | 0.30  | 27 in·lb  |         |
| Throttle Body Holder Bolts                      | 12     | 1.2   | 106 in·lb | L       |
| Throttle Cable Holder Plate Bolt                | 3.9    | 0.40  | 35 in·lb  | L       |
| Vehicle-down Sensor Bolts                       | 5.9    | 0.60  | 52 in·lb  |         |
| Water Temperature Sensor                        | 25     | 2.5   | 18        | SS      |
| <b>Cooling System</b>                           |        |       |           |         |
| Coolant By-pass Fitting Bolt                    | 8.8    | 0.90  | 78 in·lb  | L       |
| Coolant Drain Bolt (Cylinder)                   | 9.8    | 1.0   | 87 in·lb  |         |
| Coolant Drain Bolt (Water Pump)                 | 8.8    | 0.90  | 78 in·lb  |         |
| Coolant Reserve Tank Mounting Bolts             | 7.0    | 0.70  | 61 in·lb  |         |
| Impeller Bolt                                   | 9.8    | 1.0   | 87 in·lb  |         |
| Oil Cooler Mounting Bolts                       | 20     | 2.0   | 15        |         |
| Radiator Bracket Mounting Bolt                  | 9.8    | 1.0   | 87 in·lb  |         |
| Radiator Lower Bolt                             | 6.9    | 0.70  | 61 in·lb  |         |
| Radiator Upper Bolts                            | 9.8    | 1.0   | 87 in·lb  |         |
| Thermostat Housing Cover Bolts                  | 5.9    | 0.60  | 52 in·lb  |         |
| Water Hose Clamp Screws                         | 2.0    | 0.20  | 17 in·lb  |         |
| Water Hose Fitting Bolts (Cylinder)             | 9.8    | 1.0   | 87 in·lb  |         |

## PERIODIC MAINTENANCE 2-7

### Torque and Locking Agent

| Fastener  | Torque |       |           | Remarks   |
|---|--------|-------|-----------|-----------|
|   | N·m    | kgf·m | ft·lb     |           |
| Water Hose Fitting Bolts (Head Cover)           | 15     | 1.5   | 11        | L         |
| Water Pump Cover Bolts                          | 12     | 1.2   | 106 in·lb | L         |
| Water Temperature Sensor                        | 25     | 2.5   | 18        | SS        |
| <b>Engine Top End</b>                           |        |       |           |           |
| Air Suction Valve Cover Bolts                   | 9.8    | 1.0   | 87 in·lb  | L         |
| Camshaft Cap Bolts                              | 12     | 1.2   | 106 in·lb | S         |
| Camshaft Chain Tensioner Cap Bolt               | 20     | 2.0   | 15        |           |
| Camshaft Chain Tensioner Mounting Bolts         | 11     | 1.1   | 97 in·lb  |           |
| Cam Sprocket Mounting Bolts                     | 15     | 1.5   | 11        | L         |
| Cylinder Head Bolts (M9)                        | 39     | 4.0   | 29        | MO, S     |
| Cylinder Head Bolts (M6)                        | 12     | 1.2   | 106 in·lb | S         |
| Cylinder Head Cover Bolts                       | 9.8    | 1.0   | 87 in·lb  |           |
| Exhaust Butterfly Valve Actuator Mounting Nuts  | 6.9    | 0.70  | 61 in·lb  |           |
| Exhaust Butterfly Valve Actuator Pulley Bolt    | 4.9    | 0.50  | 43 in·lb  |           |
| Exhaust Butterfly Valve Cable Adjuster Locknuts | 6.9    | 0.70  | 61 in·lb  |           |
| Exhaust Butterfly Valve Cable Locknuts          | 6.9    | 0.70  | 61 in·lb  |           |
| Exhaust Butterfly Valve Cover Bolt              | 6.9    | 0.70  | 61 in·lb  |           |
| Exhaust Pipe Clamp Bolt                         | 17     | 1.7   | 13        |           |
| Exhaust Manifold Holder Nuts                    | 17     | 1.7   | 13        |           |
| Exhaust Pipe Mounting Bolt                      | 28     | 2.8   | 21        |           |
| Exhaust Manifold Holder Studs                   | –      | –     | –         | (stopped) |
| Front Camshaft Chain Guide Bolt (Lower)         | 12     | 1.2   | 106 in·lb |           |
| Front Camshaft Chain Guide Bolt (Upper)         | 25     | 2.5   | 18        |           |
| Muffler Body Clamp Bolt                         | 17     | 1.7   | 12        |           |
| Muffler Body Mounting Bolts                     | 28     | 2.8   | 21        |           |
| Muffler Rear Cover Bolts                        | 6.9    | 0.70  | 61 in·lb  |           |
| Muffler Slide Cover Bolts                       | 6.9    | 0.70  | 61 in·lb  |           |
| Muffler Upper Cover Bolts                       | 6.9    | 0.70  | 61 in·lb  |           |
| Upper Camshaft Chain Guide Bolt                 | 25     | 2.5   | 18        |           |
| Spark Plugs                                     | 13     | 1.3   | 113 in·lb |           |
| Oxygen Sensors                                  | 25     | 2.5   | 18        |           |
| Throttle Body Assy Holder Clamp Bolts           | 2.9    | 0.30  | 26 in·lb  |           |
| Throttle Body Holder Bolts                      | 12     | 1.2   | 106 in·lb | L         |
| Water Passage Plugs                             | 20     | 2.0   | 15        | L         |
| <b>Clutch</b>                                   |        |       |           |           |
| Clutch Cover Bolts (M6, L = 40 mm)              | 9.8    | 1.0   | 87 in·lb  |           |
| Clutch Cover Bolts (M6, L = 25 mm)              | 9.8    | 1.0   | 87 in·lb  |           |
| Clutch Hub Nut                                  | 135    | 14    | 100       | R         |
| Clutch Lever Clamp Bolts                        | 7.8    | 0.80  | 69 in·lb  | S         |
| Clutch Spring Bolts                             | 8.8    | 0.90  | 78 in·lb  |           |
| Sub Clutch Hub Bolts                            | 25     | 2.5   | 18        | L         |
| <b>Engine Lubrication System</b>                |        |       |           |           |
| Oil Filler Cap                                  | 2.0    | 0.20  | 17 in·lb  |           |

## 2-8 PERIODIC MAINTENANCE

2007 Kawasaki Ninja ZX-6R Motorcycle Service Repair Workshop Manual

Full Download: <https://www.aresrepairmanual.com/downloads/2007-kawasaki-ninja-zx-6r-motorcycle-service-repair-workshop-manual/>

### Torque and Locking Agent

<https://www.aresrepairmanual.com/downloads/2007-kawasaki-ninja-zx-6r-motorcycle-service-repair-workshop-manual/>

| Fastener                                  | Torque       |              |              | Remarks      |
|---|--------------|--------------|--------------|--------------|
|   | N·m          | kgf·m        | ft·lb        |              |
| Air Bleed Bolt                            | 9.8          | 1.0          | 87 in·lb     |              |
| Engine Oil Drain Bolt                     | 29           | 3.0          | 22           |              |
| Oil Cooler/Oil Filter Case Mounting Bolts | 20           | 2.0          | 15           | L            |
| Oil Pump Gear Bolt                        | 9.8          | 1.0          | 87 in·lb     | L            |
| Oil Cooler Mounting Bolts                 | 20           | 2.0          | 15           |              |
| Oil Filter                                | 31           | 3.2          | 23           | G, R         |
| Oil Filter Guard Bolts                    | 4.0          | 0.41         | 35 in·lb     | L            |
| Oil Filter Holder Bolt                    | 25           | 2.5          | 18           | L            |
| Oil Pan Bolts                             | 9.8          | 1.0          | 87 in·lb     |              |
| Oil Passage Nozzle                        | 4.9          | 0.50         | 43 in·lb     |              |
| Oil Passage Plugs (Taper)                 | 20           | 2.0          | 15           | L            |
| Oil Passage Plug (Left Side)              | 17           | 1.7          | 13           |              |
| Oil Pressure Relief Valve                 | 15           | 1.5          | 11           | L            |
| Oil Pressure Switch                       | 15           | 1.5          | 11           | SS           |
| Oil Pressure Switch Terminal Bolt         | –            | –            | –            | Hand-tighten |
| Water Hose Clamp Screws                   | 2.0          | 0.20         | 17 in·lb     |              |
| Water Pump Cover Bolts                    | 12           | 1.2          | 104 in·lb    | L            |
| <b>Engine Removal/Installation</b>        |              |              |              |              |
| Adjusting Collar Locknut                  | 49           | 5.0          | 36           | S            |
| Adjusting Collar                          | 9.8          | 1.0          | 87 in·lb     | S            |
| Lower Engine Mounting Nut                 | 44           | 4.5          | 33           | S            |
| Middle Engine Mounting Bracket Bolt       | 25           | 2.5          | 18           | S            |
| Middle Engine Mounting Nut                | 44           | 4.5          | 33           | S            |
| Upper Engine Mounting Bolts               | 44           | 4.5          | 33           | S            |
| <b>Crankshaft/Transmission</b>            |              |              |              |              |
| Breather Plate Bolts                      | 9.8          | 1.0          | 87 in·lb     | L            |
| Connecting Rod Big End Nuts               | see the text | see the text | see the text | MO           |
| Crankcase Bolts (M8) (Lower) (First)      | 15           | 1.5          | 11           | MO, S        |
| Crankcase Bolts (M8) (Lower) (Final)      | 31           | 3.2          | 23           | MO, S        |
| Crankcase Bolts (M6, L = 50 mm) (Lower)   | 12           | 1.2          | 104 in·lb    | S            |
| Gear Position Switch Screws               | 2.9          | 0.30         | 26 in·lb     | L            |
| Crankcase Bolt (M8, L = 90 mm) (Upper)    | 27           | 2.8          | 20           | S            |
| Crankcase Bolts (M8, L = 75 mm) (Upper)   | 27           | 2.8          | 20           | S            |
| Crankcase Bolts (M6, L = 68 mm) (Upper)   | 12           | 1.2          | 104 in·lb    | S            |
| Transmission Case Bolts (M8)              | 20           | 2.0          | 15           |              |
| Transmission Case Bolts (M6)              | 9.8          | 1.0          | 87 in·lb     |              |
| Piston Oil Nozzles                        | 2.9          | 0.30         | 26 in·lb     |              |
| Gear Positioning Lever Bolt               | 12           | 1.2          | 104 in·lb    |              |
| Oil Passage Plugs (Taper Side)            | 20           | 2.0          | 15           | L            |
| Oil Passage Plug (Left Side)              | 17           | 1.7          | 13           |              |
| Oil Pressure Switch                       | 15           | 1.5          | 11           | SS           |
| Fitting (Breather)                        | 15           | 1.5          | 11           | L            |

See the manual. Download All pages at:

<https://www.aresrepairmanual.com/downloads/2007-kawasaki-ninja-zx-6r-motorcycle-service-repair-workshop-manual/>