

Product: 2008 Kawasaki Ninja 250R Motorcycle Service Repair Workshop Manual  
Full Download: <https://www.arepairmanual.com/downloads/2008-kawasaki-ninja-250r-motocycle-service-repair-workshop-manual/>

# Kawasaki

# Ninja 250R



# Motorcycle Service Manual

Sample manual. Download All pages at:

<https://www.arepairmanual.com/downloads/2008-kawasaki-ninja-250r-motocycle-service-repair-workshop-manual/>

Product: 2008 Kawasaki Ninja 250R Motorcycle Service Repair Workshop Manual  
Full Download: <https://www.arepairmanual.com/downloads/2008-kawasaki-ninja-250r-motocycle-service-repair-workshop-manual/>

Sample manual. Download All pages at:  
<https://www.arepairmanual.com/downloads/2008-kawasaki-ninja-250r-motocycle-service-repair-workshop-manual/>

# Quick Reference Guide

<b>General Information</b>	<b>1</b>
<b>Periodic Maintenance</b>	<b>2</b>
<b>Fuel System (DFI)</b>	<b>3</b>
<b>Cooling System</b>	<b>4</b>
<b>Engine Top End</b>	<b>5</b>
<b>Clutch</b>	<b>6</b>
<b>Engine Lubrication System</b>	<b>7</b>
<b>Engine Removal/Installation</b>	<b>8</b>
<b>Crankshaft/Transmission</b>	<b>9</b>
<b>Wheels/Tires</b>	<b>10</b>
<b>Final Drive</b>	<b>11</b>
<b>Brakes</b>	<b>12</b>
<b>Suspension</b>	<b>13</b>
<b>Steering</b>	<b>14</b>
<b>Frame</b>	<b>15</b>
<b>Electrical System</b>	<b>16</b>
<b>Appendix</b>	<b>17</b>

This quick reference guide will assist you in locating a desired topic or procedure.

- Bend the pages back to match the black tab of the desired chapter number with the black tab on the edge at each table of contents page.
- Refer to the sectional table of contents for the exact pages to locate the specific topic required.





**Kawasaki**

**Ninja 250R**

# **Motorcycle Service Manual**

---

All rights reserved. No parts of this publication may be reproduced, stored in a retrieval system, or transmitted in any form or by any means, electronic mechanical photocopying, recording or otherwise, without the prior written permission of Quality Assurance Division/Consumer Products & Machinery Company/Kawasaki Heavy Industries, Ltd., Japan.

No liability can be accepted for any inaccuracies or omissions in this publication, although every possible care has been taken to make it as complete and accurate as possible.

The right is reserved to make changes at any time without prior notice and without incurring an obligation to make such changes to products manufactured previously. See your Motorcycle dealer for the latest information on product improvements incorporated after this publication.

All information contained in this publication is based on the latest product information available at the time of publication. Illustrations and photographs in this publication are intended for reference use only and may not depict actual model component parts.

## LIST OF ABBREVIATIONS

A	ampere(s)	lb	pound(s)
ABDC	after bottom dead center	m	meter(s)
AC	alternating current	min	minute(s)
ATDC	after top dead center	N	newton(s)
BBDC	before bottom dead center	Pa	pascal(s)
BDC	bottom dead center	PS	horsepower
BTDC	before top dead center	psi	pound(s) per square inch
°C	degree(s) Celsius	r	revolution
DC	direct current	rpm	revolution(s) per minute
F	farad(s)	TDC	top dead center
°F	degree(s) Fahrenheit	TIR	total indicator reading
ft	foot, feet	V	volt(s)
g	gram(s)	W	watt(s)
h	hour(s)	Ω	ohm(s)
L	liter(s)		

## COUNTRY AND AREA CODES

AT	Austria	WVTA (FULL N)	WVTA Model (Full Power)
CH	Switzerland	GB WVTA (FULL N)	WVTA Model (Left Side Traffic Full Power)
DE	Germany		

# Foreword

This manual is designed primarily for use by trained mechanics in a properly equipped shop. However, it contains enough detail and basic information to make it useful to the owner who desires to perform his own basic maintenance and repair work. A basic knowledge of mechanics, the proper use of tools, and workshop procedures must be understood in order to carry out maintenance and repair satisfactorily. Whenever the owner has insufficient experience or doubts his ability to do the work, all adjustments, maintenance, and repair should be carried out only by qualified mechanics.

In order to perform the work efficiently and to avoid costly mistakes, read the text, thoroughly familiarize yourself with the procedures before starting work, and then do the work carefully in a clean area. Whenever special tools or equipment are specified, do not use makeshift tools or equipment. Precision measurements can only be made if the proper instruments are used, and the use of substitute tools may adversely affect safe operation.

**For the duration of the warranty period,** we recommend that all repairs and scheduled maintenance be performed in accordance with this service manual. Any owner maintenance or repair procedure not performed in accordance with this manual may void the warranty.

To get the longest life out of your vehicle.

- Follow the Periodic Maintenance Chart in the Service Manual.
- Be alert for problems and non-scheduled maintenance.
- Use proper tools and genuine Kawasaki Motorcycle parts. Special tools, gauges, and testers that are necessary when servicing Kawasaki motorcycles are introduced by the Service Manual. Genuine parts provided as spare parts are listed in the Parts Catalog.
- Follow the procedures in this manual carefully. Don't take shortcuts.
- Remember to keep complete records of maintenance and repair with dates and any new parts installed.

---

## How to Use This Manual

---

In this manual, the product is divided into its major systems and these systems make up the manual's chapters. The Quick Reference

Guide shows you all of the product's system and assists in locating their chapters. Each chapter in turn has its own comprehensive Table of Contents.

For example, if you want ignition coil information, use the Quick Reference Guide to locate the Electrical System chapter. Then, use the Table of Contents on the first page of the chapter to find the Ignition Coil section.

Whenever you see these WARNING and CAUTION symbols, heed their instructions! Always follow safe operating and maintenance practices.

### WARNING

**This warning symbol identifies special instructions or procedures which, if not correctly followed, could result in personal injury, or loss of life.**

### CAUTION

**This caution symbol identifies special instructions or procedures which, if not strictly observed, could result in damage to or destruction of equipment.**

This manual contains four more symbols (in addition to WARNING and CAUTION) which will help you distinguish different types of information.

### NOTE

○ *This note symbol indicates points of particular interest for more efficient and convenient operation.*

- Indicates a procedural step or work to be done.
- Indicates a procedural sub-step or how to do the work of the procedural step it follows. It also precedes the text of a NOTE.
- ★ Indicates a conditional step or what action to take based on the results of the test or inspection in the procedural step or sub-step it follows.

In most chapters an exploded view illustration of the system components follows the Table of Contents. In these illustrations you will find the instructions indicating which parts require specified tightening torque, oil, grease or a locking agent during assembly.



# General Information

## Table of Contents

Before Servicing .....	1-2
Model Identification.....	1-7
General Specifications.....	1-8
Unit Conversion Table .....	1-11

## 1-2 GENERAL INFORMATION

### Before Servicing

Before starting to perform an inspection service or carry out a disassembly and reassembly operation on a motorcycle, read the precautions given below. To facilitate actual operations, notes, illustrations, photographs, cautions, and detailed descriptions have been included in each chapter wherever necessary. This section explains the items that require particular attention during the removal and reinstallation or disassembly and reassembly of general parts.

Especially note the following.

#### **Battery Ground**

Before completing any service on the motorcycle, disconnect the battery cables from the battery to prevent the engine from accidentally turning over. Disconnect the ground (-) first and then the positive (+). When completed with the service, first connect the positive (+) cable to the positive (+) terminal of the battery then the negative (-) cable to the negative terminal.

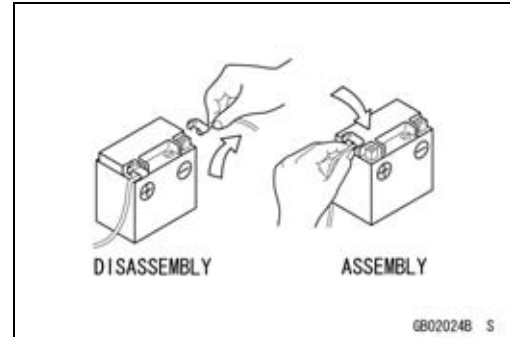

#### **Edges of Parts**

Lift large or heavy parts wearing gloves to prevent injury from possible sharp edges on the parts.

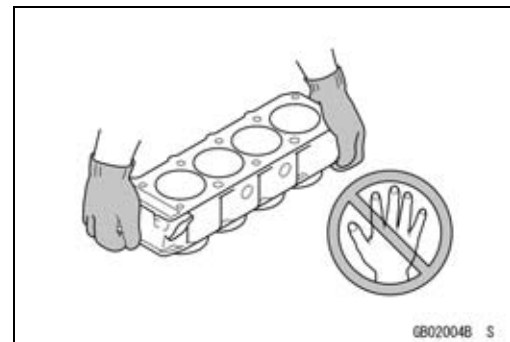

#### **Solvent**

Use a high-flash point solvent when cleaning parts. High-flash point solvent should be used according to directions of the solvent manufacturer.

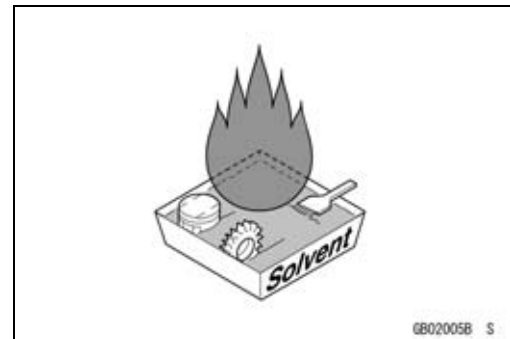

#### **Cleaning Vehicle before Disassembly**

Clean the vehicle thoroughly before disassembly. Dirt or other foreign materials entering into sealed areas during vehicle disassembly can cause excessive wear and decrease performance of the vehicle.

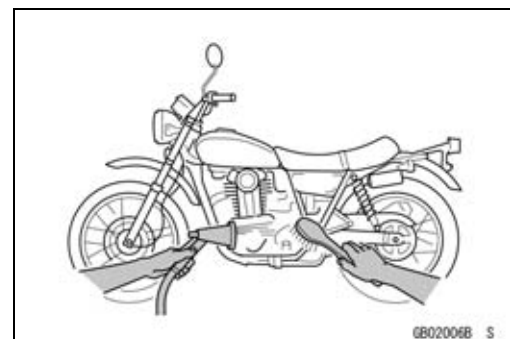

**Before Servicing**

**Arrangement and Cleaning of Removed Parts**

Disassembled parts are easy to confuse. Arrange the parts according to the order the parts were disassembled and clean the parts in order prior to assembly.

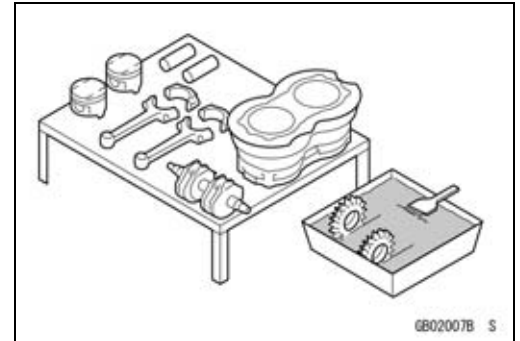

**Storage of Removed Parts**

After all the parts including subassembly parts have been cleaned, store the parts in a clean area. Put a clean cloth or plastic sheet over the parts to protect from any foreign materials that may collect before re-assembly.

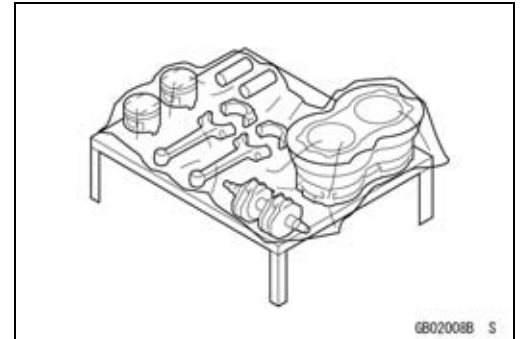

**Inspection**

Reuse of worn or damaged parts may lead to serious accident. Visually inspect removed parts for corrosion, discoloration, or other damage. Refer to the appropriate sections of this manual for service limits on individual parts. Replace the parts if any damage has been found or if the part is beyond its service limit.

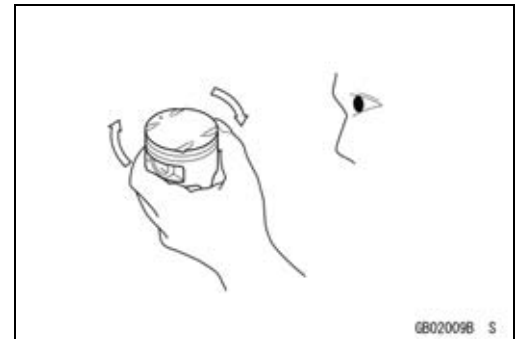

**Replacement Parts**

Replacement parts must be KAWASAKI genuine or recommended by KAWASAKI. Gaskets, O-rings, oil seals, grease seals, circlips or cotter pins must be replaced with new ones whenever disassembled.

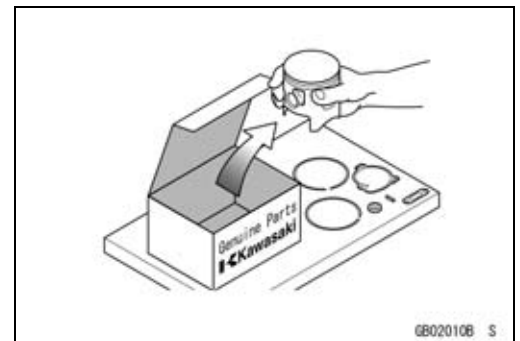

**Assembly Order**

In most cases assembly order is the reverse of disassembly, however, if assembly order is provided in this Service Manual, follow the procedures given.

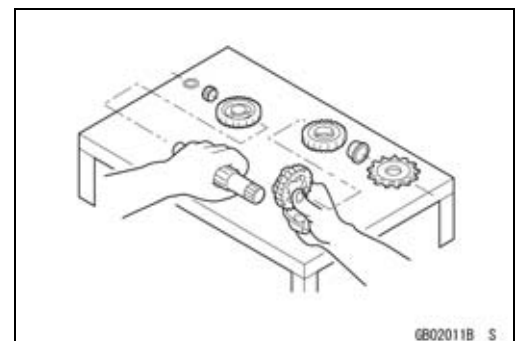

# 1-4 GENERAL INFORMATION

## Before Servicing

### **Tightening Sequence**

Generally, when installing a part with several bolts, nuts, or screws, start them all in their holes and tighten them to a snug fit. Then tighten them according to the specified sequence to prevent case warpage or deformation which can lead to malfunction. Conversely when loosening the bolts, nuts, or screws, first loosen all of them by about a quarter turn and then remove them. If the specified tightening sequence is not indicated, tighten the fasteners alternating diagonally.

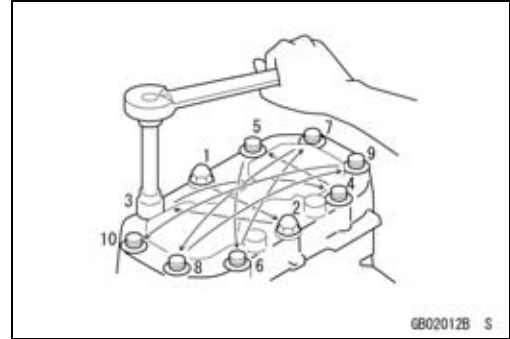

### **Tightening Torque**

Incorrect torque applied to a bolt, nut, or screw may lead to serious damage. Tighten fasteners to the specified torque using a good quality torque wrench.

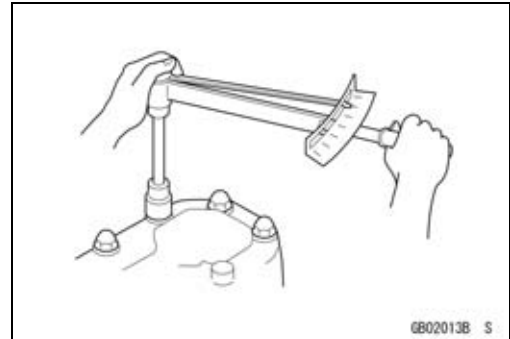

### **Force**

Use common sense during disassembly and assembly, excessive force can cause expensive or hard to repair damage. When necessary, remove screws that have a non-permanent locking agent applied using an impact driver. Use a plastic-faced mallet whenever tapping is necessary.

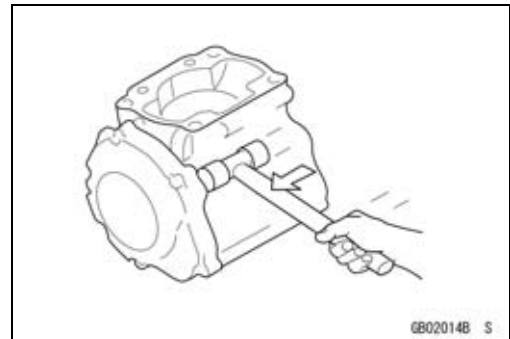

### **Gasket, O-ring**

Hardening, shrinkage, or damage of both gaskets and O-rings after disassembly can reduce sealing performance. Remove old gaskets and clean the sealing surfaces thoroughly so that no gasket material or other material remains. Install the new gaskets and replace the used O-rings when re-assembling.

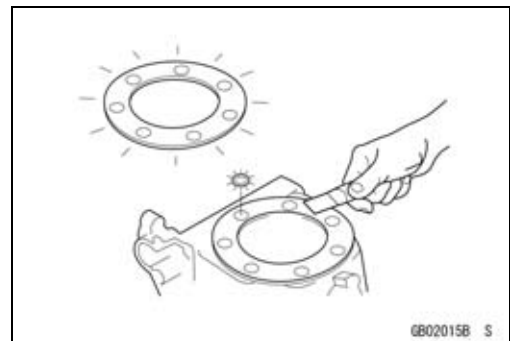

### **Liquid Gasket, Non-permanent Locking Agent**

For applications that require Liquid Gasket or a Non-permanent Locking Agent, clean the surfaces so that no oil residue remains before applying liquid gasket or non-permanent locking agent. Do not apply them excessively. Excessive application can clog oil passages and cause serious damage.



**Before Servicing**

**Press**

For items such as bearings or oil seals that must be pressed into place, apply small amount of oil to the contact area. Be sure to maintain proper alignment and use smooth movements when installing.

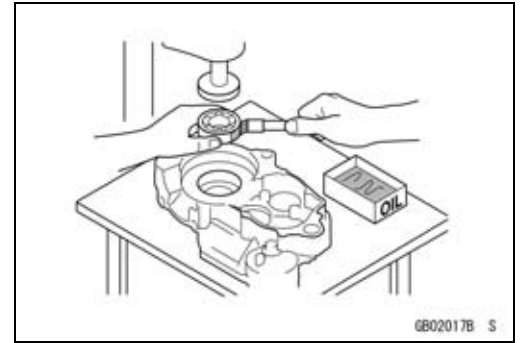

**Ball Bearing and Needle Bearing**

Do not remove pressed ball or needle unless removal is absolutely necessary. Replace with new ones whenever removed. Press bearings with the manufacturer and size marks facing out. Press the bearing into place by putting pressure on the correct bearing race as shown.

Pressing the incorrect race can cause pressure between the inner and outer race and result in bearing damage.

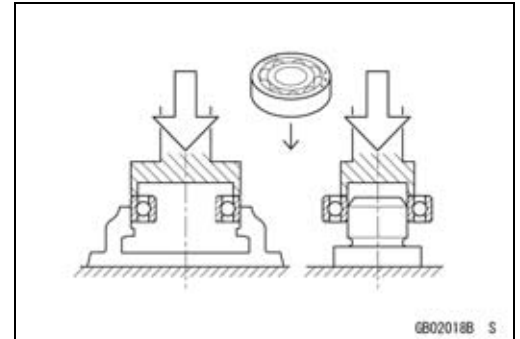

**Oil Seal, Grease Seal**

Do not remove pressed oil or grease seals unless removal is necessary. Replace with new ones whenever removed. Press new oil seals with manufacture and size marks facing out. Make sure the seal is aligned properly when installing.

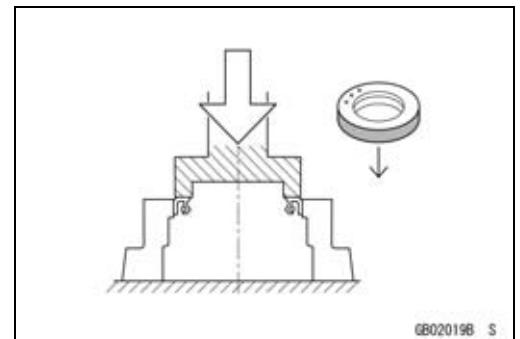

Apply specified grease to the lip of seal before installing the seal.

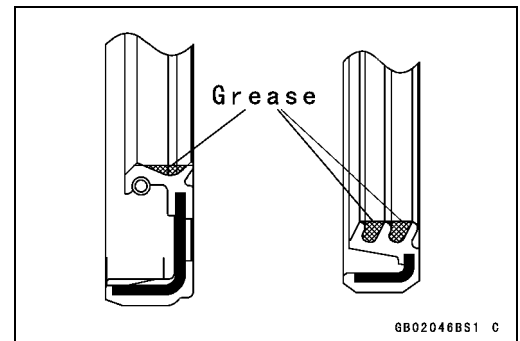

**Circlips, Cotter Pins**

Replace the circlips or cotter pins that were removed with new ones. Take care not to open the clip excessively when installing to prevent deformation.

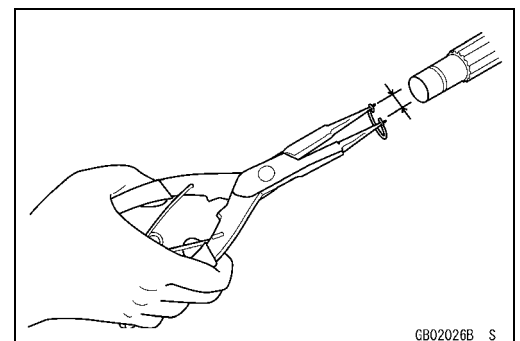

## 1-6 GENERAL INFORMATION

### Before Servicing

#### **Lubrication**

It is important to lubricate rotating or sliding parts during assembly to minimize wear during initial operation. Lubrication points are called out throughout this manual, apply the specific oil or grease as specified.

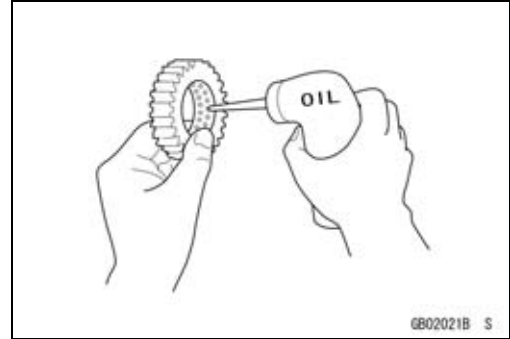

#### **Direction of Engine Rotation**

When rotating the crankshaft by hand, the free play amount of rotating direction will affect the adjustment. Rotate the crankshaft to positive direction (clockwise viewed from output side).

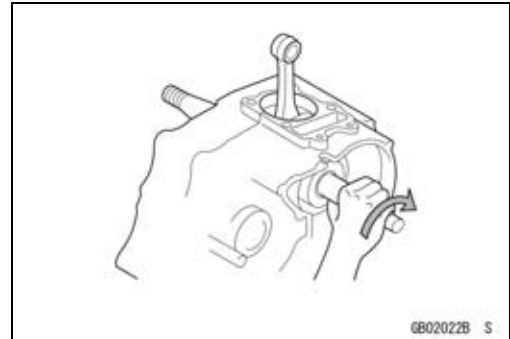

#### **Electrical Wires**

A two-color wire is identified first by the primary color and then the stripe color. Unless instructed otherwise, electrical wires must be connected to those of the same color.

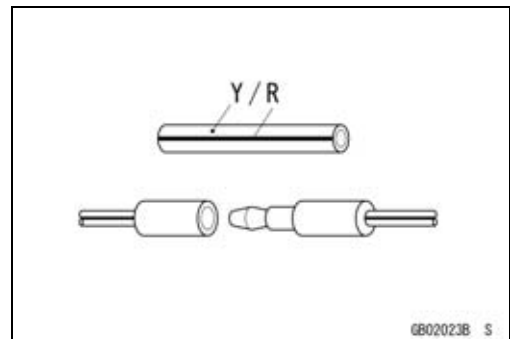

#### **Instrument**

Use a meter that has enough accuracy for an accurate measurement. Read the manufacturer's instructions thoroughly before using the meter. Incorrect values may lead to improper adjustments.

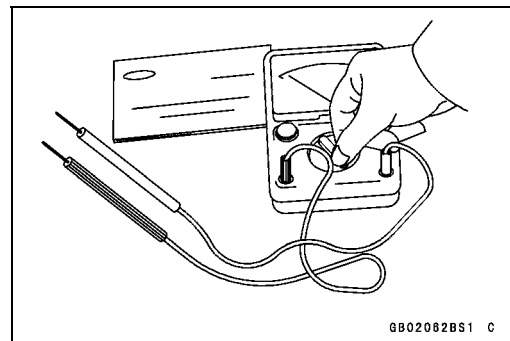

Model Identification

EX250K8F Left Side View



EX250K8F Right Side View



Frame Number



Engine Number



# 1-8 GENERAL INFORMATION

## General Specifications

Items	EX250K8F
<b>Dimensions</b> Overall Length Overall Width Overall Height Wheelbase Road Clearance Seat Height Dry Mass Curb Mass: Front Rear Fuel Tank Capacity	2 085 mm (82.09 in.) 715 mm (28.15 in.) 1 115 mm (43.90 in.) 1 400 mm (55.12 in.) 130 mm (5.12 in.) 775 mm (30.51 in.) 152 kg (335.2 lb) 82 kg (180.8 lb) 87 kg (191.8 lb) 17.8 L (4.7 US gal.)
<b>Performance</b> Minimum Turning Radius	2.7 m (8.9 ft)
<b>Engine</b> Type Cooling System Bore and Stroke Displacement Compression Ratio Maximum Horsepower Maximum Torque Carburetion System Starting System Ignition System Timing Advance Ignition Timing Spark Plug Cylinder Numbering Method Firing Order Valve Timing: Inlet: Open Close Duration Exhaust: Open Close Duration	4-stroke, DOHC, 2-cylinder Liquid-cooled 62.0 × 41.2 mm (2.44 × 1.62 in.) 249 cm <sup>3</sup> (15.19 cu in.) 11.6 : 1 24 kW (33 PS) @11 000 r/min (rpm) 22 N·m (2.2 kgf·m, 16 ft·lb) @8 200 r/min (rpm) FI (Fuel Injection) KEIHIN TTK28 × 2 Electric starter Battery and coil (transistorized) Electronically advanced (digital igniter in ECU) From 10° BTDC @1 300 r/min (rpm) 38° BTDC @6 000 r/min (rpm) NGK CR8E Left to right, 1-2 1-2 36° BTDC 56° ABDC 272° 61° BBDC 31° ATDC 272°



# 1-10 GENERAL INFORMATION

## General Specifications

Items	EX250K8F
Brake Type: Front Rear	Single disc Single disc
<b>Electrical Equipment</b> Battery Headlight: Type Bulb: High Low Tail/Brake Light Alternator: Type Rated Output	12 V 8 Ah Semi-sealed beam 12 V 55 W (quartz-halogen) × 2 12 V 55 W (quartz-halogen) 12 V 5/21 W Three-phase AC 23.0 A/14.0 V @5 000 r/min (rpm)

Specifications are subject to change without notice, and may not apply to every country.

**Unit Conversion Table**

**Prefixes for Units:**

Prefix	Symbol	Power
mega	M	× 1 000 000
kilo	k	× 1 000
centi	c	× 0.01
milli	m	× 0.001
micro	μ	× 0.000001

**Units of Mass:**

kg	×	2.205	=	lb
g	×	0.03527	=	oz

**Units of Volume:**

L	×	0.2642	=	gal (US)
L	×	0.2200	=	gal (imp)
L	×	1.057	=	qt (US)
L	×	0.8799	=	qt (imp)
L	×	2.113	=	pint (US)
L	×	1.816	=	pint (imp)
mL	×	0.03381	=	oz (US)
mL	×	0.02816	=	oz (imp)
mL	×	0.06102	=	cu in

**Units of Force:**

N	×	0.1020	=	kg
N	×	0.2248	=	lb

---

kg	×	9.807	=	N
kg	×	2.205	=	lb

**Units of Length:**

km	×	0.6214	=	mile
m	×	3.281	=	ft
mm	×	0.03937	=	in

**Units of Torque:**

N·m	×	0.1020	=	kgf·m
N·m	×	0.7376	=	ft·lb
N·m	×	8.851	=	in·lb

---

kgf·m	×	9.807	=	N·m
kgf·m	×	7.233	=	ft·lb
kgf·m	×	86.80	=	in·lb

**Units of Pressure:**

kPa	×	0.01020	=	kgf/cm <sup>2</sup>
kPa	×	0.1450	=	psi
kPa	×	0.7501	=	cmHg

---

kgf/cm <sup>2</sup>	×	98.07	=	kPa
kgf/cm <sup>2</sup>	×	14.22	=	psi
cmHg	×	1.333	=	kPa

**Units of Speed:**

km/h	×	0.6214	=	mph
------	---	--------	---	-----

**Units of Power:**

kW	×	1.360	=	PS
kW	×	1.341	=	HP

---

PS	×	0.7355	=	kW
PS	×	0.9863	=	HP

**Units of Temperature:**

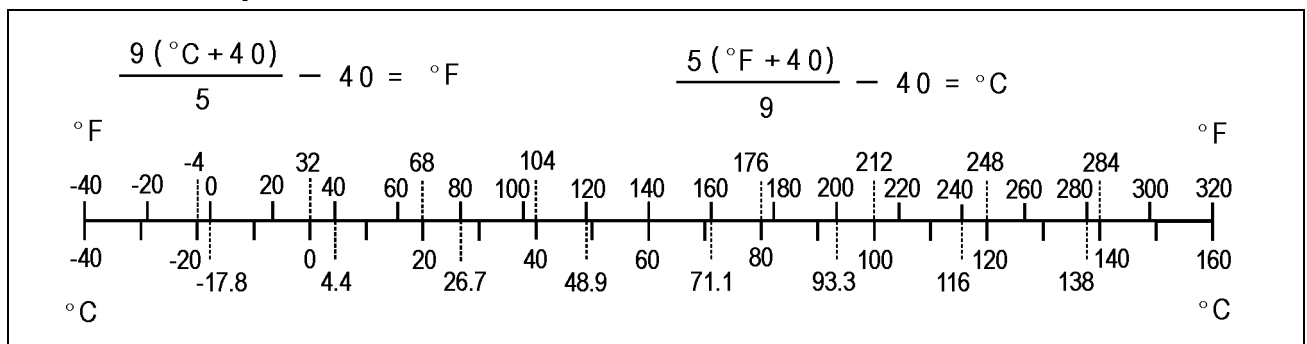



# Periodic Maintenance

## Table of Contents

Periodic Maintenance Chart .....	2-3
Torque and Locking Agent.....	2-6
Specifications .....	2-11
Special Tools .....	2-13
Periodic Maintenance Procedures.....	2-14
Fuel System (DFI).....	2-14
Air Cleaner Element Cleaning.....	2-14
Throttle Control System Inspection.....	2-14
Engine Vacuum Synchronization Inspection.....	2-15
Idle Speed Inspection .....	2-18
Idle Speed Adjustment.....	2-18
Fuel Hose Inspection (fuel leak, damage, installation condition).....	2-18
Cooling System.....	2-19
Coolant Level Inspection.....	2-19
Water Hose and Pipe Inspection (coolant leak, damage, installation condition) .....	2-20
Engine Top End .....	2-20
Valve Clearance Inspection .....	2-20
Valve Clearance Adjustment.....	2-21
Air Suction System Damage Inspection.....	2-23
Clutch.....	2-23
Clutch Operation Inspection.....	2-23
Wheels/Tires.....	2-24
Air Pressure Inspection.....	2-24
Wheel/Tire Damage Inspection.....	2-25
Tire Tread Wear Inspection.....	2-25
Wheel Bearing Damage Inspection .....	2-26
Final Drive.....	2-26
Drive Chain Lubrication Condition Inspection .....	2-26
Drive Chain Slack Inspection .....	2-27
Drive Chain Slack Adjustment .....	2-27
Wheel Alignment Inspection .....	2-28
Drive Chain Wear Inspection .....	2-29
Chain Guide Wear Inspection .....	2-29
Brakes.....	2-30
Brake Fluid Leak (Brake Hose and Pipe) Inspection .....	2-30
Brake Hose and Pipe Damage and Installation Condition.....	2-30
Brake Fluid Level Inspection.....	2-30
Brake Pad Wear Inspection .....	2-31
Brake Operation Inspection .....	2-31
Brake Light Switch Operation Inspection .....	2-32
Suspension .....	2-32
Front Forks/Rear Shock Absorber Operation Inspection .....	2-32
Front Fork Oil Leak Inspection.....	2-33
Rear Shock Absorber Oil Leak Inspection .....	2-33
Rocker Arm Operation Inspection.....	2-33
Tie-Rod Operation Inspection .....	2-33
Swingarm Pivot Lubrication .....	2-34
Steering .....	2-34
Steering Play Inspection .....	2-34
Steering Play Adjustment.....	2-35

## 2-2 PERIODIC MAINTENANCE

---

Steering Stem Bearing Lubrication .....	2-35
Electrical System .....	2-36
Lights and Switches Operation Inspection.....	2-36
Headlight Aiming Inspection .....	2-38
Sidestand Switch Operation Inspection .....	2-39
Engine Stop Switch Operation Inspection.....	2-40
Others .....	2-40
Chassis Parts Lubrication .....	2-40
Bolts, Nuts and Fasteners Tightness Inspection.....	2-42
Replacement Parts .....	2-43
Air Cleaner Element Replacement.....	2-43
Fuel Hose Replacement .....	2-44
Coolant Change .....	2-45
Radiator Hose and O-ring Replacement.....	2-48
Engine Oil Change.....	2-48
Oil Filter Replacement .....	2-49
Brake Hose and Pipe Replacement.....	2-50
Brake Fluid Change .....	2-50
Master Cylinder Rubber Parts Replacement .....	2-51
Caliper Rubber Parts Replacement .....	2-53
Spark Plug Replacement .....	2-54



## 2-4 PERIODIC MAINTENANCE

### Periodic Maintenance Chart

ITEM	FREQUENCY	Whichever comes first ↓	* ODOMETER READING × 1 000 km (× 1 000 mile)						See Page	
			1 (0.6)	6 (4)	12 (7.5)	18 (12)	24 (15)	30 (20)		36 (24)
Brake fluid level - inspect	6 months	↓	•	•	•	•	•	•	•	2-30
Brake pad wear - inspect #				•	•	•	•	•	•	2-31
Brake operation (effectiveness, play, no drag) - inspect	year		•	•	•	•	•	•	•	2-31
Brake light switch operation - inspect			•	•	•	•	•	•	•	2-32
<b>Suspension</b>										
Front forks/rear shock absorber operation (damping and smooth stroke) - inspect					•		•		•	2-32
Front forks/rear shock absorber oil leak - inspect	year			•		•		•		2-33
Rocker arm operation - inspect				•		•		•		2-33
Tie-rods operation - inspect				•		•		•		2-33
Swingarm pivot - lubricate						•				2-34
<b>Steering</b>										
Steering play - inspect	year		•		•		•		•	2-34
Steering stem bearings - lubricate	2 years					•				2-35
<b>Electrical System</b>										
Lights and switches operation - inspect	year			•		•		•		2-36
Headlight aiming - inspect	year			•		•		•		2-38
Sidestand switch operation - inspect	year			•		•		•		2-39
Engine stop switch operation - inspect	year			•		•		•		2-40
<b>Others</b>										
Chassis parts - lubricate	year			•		•		•		2-40
Bolts and nuts tightness - inspect			•		•		•		•	2-42

#: Service more frequently when operating in severe conditions; dusty, wet, muddy, high speed or frequent starting/stopping.

\*: For higher odometer readings, repeat at the frequency interval established here.

**Periodic Maintenance Chart**

**Periodic Replacement Parts**

ITEM	FREQUENCY ↓ Every	* ODOMETER READING × 1 000 km (× 1 000 mile)					See Page
		1 (0.6)	12 (7.5)	24 (15)	36 (24)	48 (30)	
Air cleaner element # - replace	2 years						2-43
Fuel hose - replace	4 years					●	2-44
Coolant - change	3 years				●		2-45
Radiator hose and O-ring - replace	3 years				●		2-48
Engine oil # - change	year	●	●	●	●	●	2-48
Oil filter - replace	year	●	●	●	●	●	2-49
Brake hose and pipe - replace	4 years					●	2-50
Brake fluid - change	2 years			●		●	2-50
Rubber parts of master cylinder and caliper - replace	4 years					●	2-51, 2-53
Spark plug - replace			●	●	●	●	2-54

#: Service more frequently when operating in severe conditions; dusty, wet, muddy, high speed or frequent starting/stopping.

\*: For higher odometer readings, repeat at the frequency interval established here.

## 2-6 PERIODIC MAINTENANCE

### Torque and Locking Agent

The following tables list the tightening torque for the major fasteners requiring use of a non-permanent locking agent or silicone sealant etc.

Letters used in the "Remarks" column mean:

G: Apply grease.

L: Apply a non-permanent locking agent.

MO: Apply molybdenum disulfide grease oil solution.

(mixture of the engine oil and molybdenum disulfide grease in a weight ratio 10:1)

S: Follow the specified tightening sequence.

Si: Apply silicone grease (ex. PBC grease).

SS: Apply silicone sealant.

Fastener	Torque			Remarks
	N·m	kgf·m	ft·lb	
<b>Fuel System (DFI)</b>				
Air Cleaner Housing Cap Bolts	2.5	0.25	22 in·lb	
Air Cleaner Housing Mounting Bolts	9.8	1.0	87 in·lb	
Air Cleaner Housing Screws	1.15	0.12	10 in·lb	
Air Duct Clamp Screws	2.0	0.20	18 in·lb	
Crankshaft Sensor Screws	3.0	0.31	27 in·lb	
Delivery Pipe Assy Mounting Screws	3.4	0.35	30 in·lb	
Fuel Pump Bolts	9.8	1.0	87 in·lb	L
Inlet Air Temperature Sensor Screw	1.2	0.12	11 in·lb	
Oxygen Sensor	44.1	4.50	32.5	
Speed Sensor Bolt	7.8	0.80	69 in·lb	L
Throttle Body Assy Holder Clamp Screws	2.0	0.20	18 in·lb	
Water Temperature Sensor	25	2.5	18	
<b>Cooling System</b>				
Coolant Drain Bolt (Cylinder)	5.9	0.60	52 in·lb	
Coolant Drain Bolt (Water Pump)	9.8	1.0	87 in·lb	
Radiator Bolts	9.8	1.0	87 in·lb	
Radiator Cap Bracket Bolt	9.8	1.0	87 in·lb	
Radiator (Water) Hose Clamp Screws	1.5	0.15	13 in·lb	
Reserve Tank Bolts	9.8	1.0	87 in·lb	
Reserve Tank Bracket Bolts	9.8	1.0	87 in·lb	
Reserve Tank Cap	—	—	—	Hand -Tighten
Resistor Bolt	7.8	0.80	69 in·lb	
Thermostat Cover Bolts	9.8	1.0	87 in·lb	
Thermostat Housing Mounting Bolts	9.8	1.0	87 in·lb	
Water Hose Fitting Bolts	9.8	1.0	87 in·lb	
Water Pipe Bolts	9.8	1.0	87 in·lb	
Water Pump Bolts	9.8	1.0	87 in·lb	
Water Pump Cover Bolts	9.8	1.0	87 in·lb	
Water Temperature Sensor	25	2.5	18	
<b>Engine Top End</b>				
Air Suction Valve Cover Bolts	9.8	1.0	87 in·lb	

## PERIODIC MAINTENANCE 2-7

### Torque and Locking Agent

Fastener	Torque			Remarks
	N·m	kgf·m	ft·lb	
Air Switching Valve Bracket Bolts	9.8	1.0	87 in·lb	
Camshaft Cap Bolts	12	1.2	106 in·lb	S
Camshaft Chain Tensioner Cap Bolt	5.0	0.51	44 in·lb	
Camshaft Chain Tensioner Mounting Bolts	9.8	1.0	87 in·lb	
Camshaft Sprocket Bolts	15	1.5	11	L
Coolant Drain Bolt (Cylinder)	5.9	0.60	52 in·lb	
Cylinder Head Bolts (M8)	31.4	3.2	23.2	MO, S
Cylinder Head Bolt (M6)	12	1.2	106 in·lb	S
Cylinder Head Cover Bolts	9.8	1.0	87 in·lb	
Cylinder Head Jacket Plugs	20	2.0	15	L
Exhaust Pipe Holder Nuts	12	1.2	106 in·lb	
Exhaust Pipe Mounting Bolt	9.8	1.0	87 in·lb	
Muffler Body Clamp Bolt	17	1.7	13	
Muffler Body Mounting Bolt	30	3.1	22	
Muffler Body Rear Cover Bolts	9.8	1.0	87 in·lb	L
Muffler Cover Bolts	9.8	1.0	87 in·lb	
Muffler Cover Clamp Bolt	9.8	1.0	87 in·lb	
Muffler Cover Clamp Screw	6.9	0.70	61 in·lb	
Rear Camshaft Chain Guide Bolt	17	1.7	13	
Spark Plugs	13	1.3	115 in·lb	
Throttle Body Assy Holder Clamp Screws	2.0	0.20	18 in·lb	
<b>Clutch</b>				
Clutch Cover Bolts	9.8	1.0	87 in·lb	
Clutch Hub Nut	132	13.5	97.4	
Clutch Lever Clamp Bolt	8.8	0.90	78 in·lb	
Clutch Spring Bolts	8.8	0.90	78 in·lb	
Oil Filler Plug	–	–	–	Hand -Tighten
<b>Engine Lubrication System</b>				
Crankcase Oil Passage Plug	15	1.5	11	
Engine Oil Drain Bolt (Crankcase)	19.6	2.0	14.5	
Engine Oil Drain Bolt (Oil Screen Cover)	19.6	2.0	14.5	
Oil Breather Mounting Bolts	9.8	1.0	87 in·lb	L
Oil Filter Mounting Bolt	19.6	2.0	14.5	
Oil Hose Banjo Bolts	19.6	2.0	14.5	
Oil Passage Plugs	20	2.0	15	L
Oil Pipe Banjo Bolt	12	1.2	106 in·lb	
Oil Pressure Relief Valve	15	1.5	11	L
Oil Pressure Switch	15	1.5	11	SS
Oil Pressure Switch Terminal Bolt	1.5	0.15	13 in·lb	G
Oil Pump Mounting Bolts	9.8	1.0	87 in·lb	L
Oil Screen Cover Bolts	9.8	1.0	87 in·lb	

## 2-8 PERIODIC MAINTENANCE

### Torque and Locking Agent

Fastener	Torque			Remarks
	N·m	kgf·m	ft·lb	
<b>Engine Removal/Installation</b>				
Engine Mounting Bracket Bolts and Nuts	69	7.0	51	
Engine Mounting Nuts	69	7.0	51	
<b>Crankshaft/Transmission</b>				
Connecting Rod Big End Nuts	27.5	2.8	20	MO
Crankcase Bolts (M8, L = 90 mm)	24	2.4	18	MO, S
Crankcase Bolts (M8, L = 73 mm)	19	1.9	14	MO, S
Crankcase Bolts (M6)	12	1.2	106 in·lb	
Neutral Switch	15	1.5	11	
Oil Breather Mounting Bolts	9.8	1.0	87 in·lb	L
Shift Drum Bearing Holder Bolts	12	1.2	106 in·lb	L
Shift Drum Pin Plate Bolt	9.0	0.92	80 in·lb	L
Shift Drum Positioning Bolt	24.5	2.5	18	
Shift Lever Bolt	12	1.2	106 in·lb	
Shift Pedal Mounting Bolt	25	2.5	18	
Shift Shaft Return Spring Pin	19.6	2.0	14.5	L
Starter Motor Clutch Bolts	34.3	3.5	25	L
Tie-Rod Locknuts	7.0	0.71	62 in·lb	
<b>Wheels/Tires</b>				
Front Axle Nut	88	9.0	65	
Rear Axle Nut	98	10.0	72.3	
<b>Final Drive</b>				
Engine Sprocket Cover Bolts	9.8	1.0	87 in·lb	
Engine Sprocket Nut	127	13.0	93.7	MO
Rear Axle Nut	98	10.0	72.3	
Rear Sprocket Nuts	59	6.0	44	
Speed Sensor Mounting Bracket Bolts	9.8	1.0	87 in·lb	L
<b>Brakes</b>				
Bleed Valves	5.5	0.56	49 in·lb	L
Brake Hose Banjo Bolts	25	2.5	18	
Brake Lever Pivot Bolt	5.9	0.60	52 in·lb	Si
Brake Lever Pivot Bolt Locknut	5.9	0.60	52 in·lb	
Brake Pedal Bolt	8.8	0.90	78 in·lb	
Front Brake Disc Mounting Bolts	27	2.8	20	L
Front Brake Light Switch Screw	1.2	0.12	11 in·lb	
Front Brake Pad Pins	17.2	1.8	13	
Front Brake Reservoir Cap Screws	1.5	0.15	13 in·lb	
Front Caliper Holder Pin Bolt	17.2	1.8	13	Si
Front Caliper Mounting Bolts	25	2.5	18	
Front Master Cylinder Clamp Bolts	8.8	0.90	78 in·lb	S
Rear Brake Disc Mounting Bolts	27	2.8	20	L
Rear Brake Pad Pins	17.2	1.8	13	
Rear Caliper Holder Pin Bolt	17.2	1.8	13	Si

## PERIODIC MAINTENANCE 2-9

### Torque and Locking Agent

Fastener	Torque			Remarks
	N·m	kgf·m	ft·lb	
Rear Caliper Mounting Bolts	25	2.5	18	
Rear Master Cylinder Mounting Bolts	25	2.5	18	
Rear Master Cylinder Push Rod Locknut	17.2	1.8	13	
<b>Suspension</b>				
Front Fork Bottom Allen Bolts	20	2.0	15	L
Lower Front Fork Clamp Bolts	30	3.1	22	
Rear Shock Absorber Nuts	59	6.0	44	
Swingarm Pivot Shaft Nut	98	10.0	72.3	
Tie-Rod Nuts	59	6.0	44	
Uni-Trak Rocker Arm Nut	59	6.0	44	
Upper Front Fork Clamp Bolts	20	2.0	15	
<b>Steering</b>				
Handlebar Mounting Bolts	25	2.5	18	
Lower Front Fork Clamp Bolts	30	3.1	22	
Steering Stem Head Bolt	44	4.5	32	
Steering Stem Nut	4.9	0.50	43 in·lb	
Switch Housing Screws	3.5	0.36	31 in·lb	
Upper Front Fork Clamp Bolts	20	2.0	15	
<b>Frame</b>				
Front Footpeg Bracket Bolts	25	2.5	18	
Rear Footpeg Bracket Bolts	25	2.5	18	
Sidestand Nut	39	4.0	29	
Sidestand Switch Bolt	8.8	0.90	78 in·lb	L
Windshield Mounting Bolts	0.42	0.043	3.7 in·lb	
<b>Electrical System</b>				
Alternator Cover Bolts	9.8	1.0	87 in·lb	
Alternator Rotor Bolt	88.2	9.0	65	S
Crankshaft Sensor Screws	3.0	0.31	27 in·lb	
Front Brake Light Switch Screw	1.2	0.12	11 in·lb	
Fuel Pump Bolts	9.8	1.0	87 in·lb	L
License Plate Light Cover Screws	0.90	0.092	8.0 in·lb	
License Plate Light Mounting Screws	1.2	0.12	11 in·lb	
Neutral Switch	15	1.5	11	
Oil Pressure Switch	15	1.5	11	SS
Oil Pressure Switch Terminal Bolt	1.5	0.15	13 in·lb	G
Oxygen Sensor	44.1	4.50	32.5	
Plugs (Alternator Cover)	–	–	–	Hand -Tighten
Regulator/Rectifier Bolts	9.8	1.0	87 in·lb	
Resistor Bolt	7.8	0.80	69 in·lb	
Sidestand Switch Bolt	8.8	0.90	78 in·lb	L
Spark Plugs	13	1.3	115 in·lb	
Speed Sensor Bolt	7.8	0.80	69 in·lb	L

Fastener	Torque			Remarks
	N·m	kgf·m	ft·lb	
Starter Motor Cable Terminal Nut	9.8	1.0	87 in·lb	L
Starter Motor Clutch Bolts	34.3	3.5	25	
Starter Motor Mounting Bolts	9.8	1.0	87 in·lb	
Starter Motor Terminal Locknut	6.9	0.70	61 in·lb	
Starter Motor Through Bolts	3.4	0.35	30 in·lb	
Starter Relay Cable Terminal Nuts	5.0	0.51	44 in·lb	
Stator Coil Bolts	12	1.2	106 in·lb	
Switch Housing Screws	3.5	0.36	31 in·lb	
Tail/Brake Light Mounting Bolts	5.9	0.60	52 in·lb	
Water Temperature Sensor	25	2.5	18	

The table below, relating tightening torque to thread diameter, lists the basic torque for the bolts and nuts. Use this table for only the bolts and nuts which do not require a specific torque value. All of the values are for use with dry solvent-cleaned threads.

### Basic Torque for General Fasteners

Threads Diameter (mm)	Torque		
	N·m	kgf·m	ft·lb
5	3.4 ~ 4.9	0.35 ~ 0.50	30 ~ 43 in·lb
6	5.9 ~ 7.8	0.60 ~ 0.80	52 ~ 69 in·lb
8	14 ~ 19	1.4 ~ 1.9	10.0 ~ 13.5
10	25 ~ 34	2.6 ~ 3.5	19.0 ~ 25
12	44 ~ 61	4.5 ~ 6.2	33 ~ 45
14	73 ~ 98	7.4 ~ 10.0	54 ~ 72
16	115 ~ 155	11.5 ~ 16.0	83 ~ 115
18	165 ~ 225	17.0 ~ 23.0	125 ~ 165
20	225 ~ 325	23.0 ~ 33.0	165 ~ 240