

Shop Manual

WF450-3

WF450T-3

TRASH COMPACTOR

SERIAL NUMBER

WF450-3
WF450T-3

W078-54101 AND UP
W077-54101 AND UP

- This shop manual may contain attachments and optional equipment that are not available in your area. Please consult your local KOMATSU distributor for those items you may require. Materials and specifications are subject to change without notice.
- WF450-3, WF450T-3 mount the S6D125-2 engine.
For details of the engine, see the 125-2 Series Engine Shop Manual

Product: 2001 KOMATSU WF450-3,WF450T-3 Trash Compactors Service Repair Workshop Manual
Full Download: <https://www.arepairmanual.com/downloads/2001-komatsu-wf450-3-wf450t-3-trash-compactors-service-repair-workshop-manual/>

Sample of manual. Download All 324 pages at:
<https://www.arepairmanual.com/downloads/2001-komatsu-wf450-3wf450t-3-trash-compactors-service-repair-workshop-manual/>

CONTENTS

No. of page

00	SAFETY	00-1
01	GENERAL	01-1
10	STRUCTURE AND FUNCTION	10-1
20	TESTING AND ADJUSTING	20-1
30	DISASSEMBLY AND ASSEMBLY	30-1
40	MAINTENANCE STANDARD	40-1
90	OTHERS	90-1

00 SAFETY

Safety notice	00-2
Foreword	00-6
How to read the shop manual	00-7
Volumes	00-7
Distribution and updating	00-7
Filing method	00-7
Symbols	00-8
Hoisting instructions	00-9

Safety notice



Important Safety Notice

Proper service and repair is extremely important for safe machine operation. Some of the described service and repair techniques require the use of tools specially designed by Komatsu for the specific purpose.

To prevent injury to workers, the symbol  is used to mark safety precautions in this manual. The cautions accompanying these symbols must always be followed carefully. If any dangerous situation arises or may possibly arise, first consider safety, and take the necessary actions to deal with the situation.



General Precautions

Mistakes in operation are extremely dangerous. Read the **OPERATION AND MAINTENANCE MANUAL** carefully before operating the machine! Always follow the safety rules valid in your country carefully!

1. Before carrying out any greasing or repairs, read all the precautions given on the decals which are fixed to the machine.
2. When carrying out any operation, always wear safety shoes and helmet. Do not wear loose work clothes, or clothes with buttons missing.
 - Always wear safety glasses when hitting parts with a hammer.
 - Always wear safety glasses when grinding parts with a grinder, etc.
3. If welding repairs are needed, always have a trained, experienced welder carry out the work. When carrying out welding work, always wear welding gloves, apron, glasses, cap and other clothes suited for welding work.
4. When carrying out any operation with two or more workers, always agree on the operating procedure before starting. Always inform your fellow workers before starting any step of the operation. Before starting work, hang UNDER REPAIR signs on the controls in the operator's compartment.
5. Keep all tools in good condition and learn the correct way to use them.
6. Decide a place in the repair workshop to keep tools and removed parts. Always keep the tools and parts in their correct places. Always keep the work area clean and make sure that there is no dirt or oil on the floor. Never smoke while working. Smoke only in the areas provided for smoking.

Preparations for work

1. Before adding oil or making any repairs, park the machine on hard, level ground, and block the wheels or tracks to prevent the machine from moving.
2. Before starting work, lower blade, ripper, bucket or any other work equipment to the ground and install the safety bar on the frame. If this is not possible, insert the safety pin or use blocks to prevent the work equipment from falling. In addition, be sure to lock all the control levers and hang warning signs on them.
3. When disassembling or assembling, support the machine with blocks, jacks or stands before starting work.
4. Remove all mud and oil from the steps or other places used to get on and off the machine. Always use the handrails, ladders or steps when getting on or off the machine. Never jump on or off the machine. If it is impossible to use the handrails, ladders or steps, use a stand to provide safe footing.

Precautions during work

1. When measuring hydraulic pressure, check that the measuring tool is correctly assembled before taking any measurements.
2. When removing the oil filler cap, drain plug or hydraulic pressure measuring plugs, loosen them slowly to prevent the oil from spurting out.
Before disconnecting or removing components of the oil, water or air circuits, first remove the pressure completely from the circuit.
3. The water and oil in the circuits are hot when the engine is stopped, so be careful not to get burned.
Wait for the oil and water to cool before carrying out any work on the oil or water circuits.
4. Before starting work, remove the leads from the battery. Always remove the lead from the negative (-) terminal first.
5. When raising heavy components, use a hoist or crane.
Check that the wire rope, chains and hooks are free from damage.
Always use lifting equipment which has ample capacity.
Install the lifting equipment at the correct places. Use a hoist or crane and operate slowly to prevent the component from hitting any other part.
Do not work with any part still raised by the hoist or crane.
6. When removing covers which are under internal pressure or under pressure from a spring, always leave two bolts in position on opposite sides. Slowly release the pressure, then slowly loosen the bolts to remove.
7. When removing components, be careful not to break or damage the wiring. Damaged wiring may cause electrical fires.
8. When removing piping, stop the fuel or oil from spilling out. If any fuel or oil drips onto the floor, wipe it up immediately. Fuel or oil on the floor can cause you to slip, or can even start fires.
9. As a general rule, do not use gasoline to wash parts. In particular, use only the minimum of gasoline when washing electrical parts. Do not smoke!
10. Be sure to assemble all parts again in their original places.
Replace any damaged parts with new parts.

When installing hoses and wires, be sure that they will not be damaged by contact with other parts when the machine is being operated.
11. When installing high pressure hoses, make sure that they are not twisted.
Damaged tubes are dangerous, so be extremely careful when installing tubes for high pressure circuits. Also, check that connecting parts are correctly installed.

12. When aligning two holes, never insert your fingers or hand. Be careful not to get your fingers caught in a hole.
13. When assembling or installing parts, always use the specified tightening torques. When installing protective parts such as guards, or parts which vibrate violently or rotate at high speed, be particularly careful to check that they are installed correctly.

Foreword

General

This shop manual has been prepared as an aid to improve the quality of repairs by giving the service personnel an accurate understanding of the product and by showing them the correct way to perform repairs and make judgements. Make sure you understand the contents of this manual and use it to full effect at every opportunity.

This shop manual mainly contains the necessary technical information for operations performed in a service workshop. For ease of understanding, the manual is divided into the following chapters; these chapters are further divided into the each main group of components:

Structure and function

This section explains the structure and function of each component. It serves not only to give an understanding of the structure, but also serves as reference material for troubleshooting.

Testing and adjusting

This section explains checks to be made before and after performing repairs, as well as adjustments to be made at completion of the checks and repairs. Troubleshooting charts correlating "Problems" to "Causes" are also included in this section.

Disassembly and assembly

This section explains the order to be followed when removing, installing, disassembling or assembling each component, as well as precautions to be taken for these operations.

Maintenance standard

This section gives the judgement standards when inspecting disassembled parts.

NOTE

The specifications contained in this shop manual are subject to change at any time and without any advance notice. Use the specifications given in the book with the latest date.

How to read the shop manual

Volumes

Shop manuals are issued as a guide to carrying out repairs.

Distribution and updating

Any additions, amendments or other changes will be sent to Komatsu distributors.

Get the most up-to-date information before you start any work.

Filing method

1. See the page number on the bottom of the page. File the pages in correct order.
2. Following examples show how to read the page number.

Example 1 (Chassis volume):

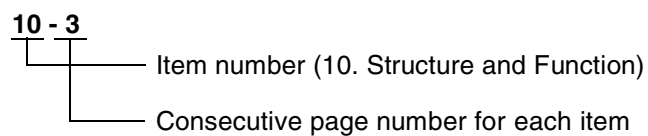





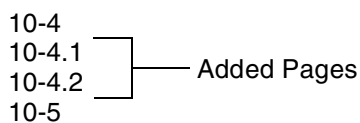

3. Additional pages: Additional pages are indicated by a point (.) and number after the page number. File as in the example.

Example:



Symbols

So that the shop manual can be of ample practical use, important safety and quality portions are marked with the following symbols:

Symbol	Item	Remarks
	Safety	Special safety precautions are necessary when performing the work.
	Caution	Special technical precautions or other precautions for preserving standards are necessary when performing the work.
	Weight	Weight of parts of systems. Caution necessary when selecting hoisting wire, or when working posture is important, etc.
	Tightening torque	Places that require special attention for the tightening torque during assembly.
	Coat	Places to be coated with adhesives and lubricants, etc.
	Oil, water	Places where oil, water or fuel must be added, and the capacity.
	Drain	Places where oil or water must be drained, and quantity to be drained.

Hoisting instructions



Heavy parts (25kg or more) must be lifted with a hoist, etc. In the DISASSEMBLY AND ASSEMBLY section, every part weighing 25 kg or more is indicated clearly with the symbol:



If a part cannot be smoothly removed from the machine by hoisting, the following checks should be made:

1. Check for removal of all bolts fastening the part to the relative parts.
2. Check for existence of another part causing interference with the part to be removed.

Wire ropes

1. Use adequate ropes depending on the weight of parts to be hoisted, referring to the table below:
 - The allowable load in tons, is given by vertical tensible force.
 - The allowable load value is estimated to be one-sixth or one-seventh of the breaking strength of the rope used.

Wire ropes: (Standard "Z" or "S" twist ropes without galvanizing)	
Rope diameter (mm)	Allowable load (tons)
10	1.0
11.2	1.4
12.5	1.6
14	2.2
16	2.8
18	3.6
20	4.4
22.4	5.6
30	10.0
40	18.0
50	28.0
60	40.0

2. Sling wire ropes from the middle portion of the hook.

Slings near the edge of the hook may cause the rope to slip off the hook during hoisting, and a serious accident can result. Hooks have maximum strength at the middle portion.

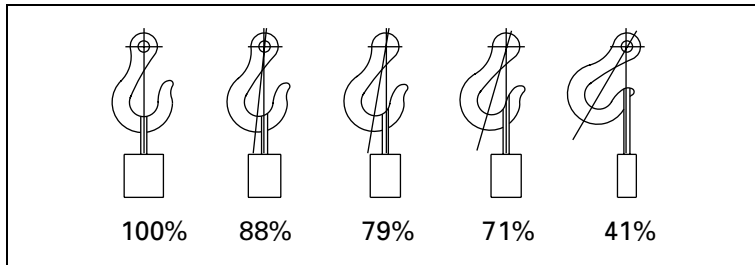

3. Do not sling a heavy load with one rope alone, but sling with two or more ropes symmetrically wound onto the load.



Slings with one rope may cause turning of the load during hoisting, untwisting of the rope, or slipping of the rope from its original winding position on the load, which can result in a dangerous accident.

4. Do not sling a heavy load with ropes forming a wide hanging angle from the hook.

When hoisting a load with two or more ropes, the force subjected to each rope will increase with the hanging angles.

The table below shows the variation of allowable load (kg) when hoisting is made with two ropes, each of which is allowed to sling up to 1000 kg vertically, at various hanging angles.

When two ropes sling a load vertically, up to 2000 kg of total weight can be suspended. This weight becomes 1000 kg when two ropes make a 120° hanging angle. On the other hand, two ropes are subjected to an excessive force as large as 4000 kg if they sling a 2000 kg load at a lifting angle of 150°.

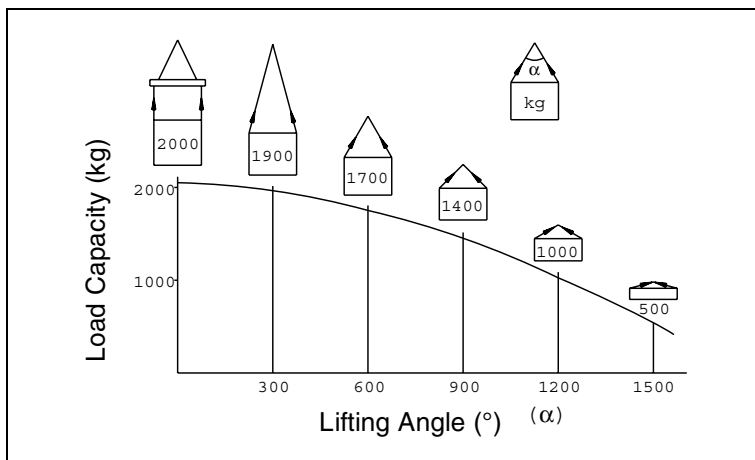

01 GENERAL

Specifications	01-2
WF450-3	01-2
WF450T-3	01-4
Weight Table	01-6

Specifications

WF450-3

Machine model			WF450-3	
Serial No.			54101 and up	
Weight	Operating weight	kg		
	Distribution (front)	kg		
	Distribution (rear)	kg		
Performance	Bucket capacity (piled)	m ³		
	Rated load	kg		
	Travel speed	FORWARD 1st	km/h	6.2
		FORWARD 2nd	km/h	11.2
		FORWARD 3rd	km/h	19.8
		FORWARD 4th	km/h	31.5
		REVERSE 1st	km/h	6.4
		REVERSE 2nd	km/h	11.7
		REVERSE 3rd	km/h	20.6
		REVERSE 4th	km/h	32.7
Max. rimpull	kN {kg}	204 {20,800}		
Gradeability	deg	25.0		
Min. turning radius	Center of outside wheel	mm		
	Outside portion of chassis (with BOC)	mm		
Engine	Model		Komatsu SA6D125E-2	
	Type		4-cycle, water-cooled, in-line, 6-cylinder direct injection, with turbocharger, after-cooler	
	No. of cylinders – bore x stroke	mm	6 – 125 mm × 150 mm	
	Piston displacement	l {cc}	11.04 {11,040}	
	Flywheel horsepower	kW {HP}/rpm	193.4 {260}/2,200	
	Maximum torque	Nm {kgm}/rpm	1,050 {107}/1,400	
	Fuel consumption ratio	g/kWh {g/HPh}	207 {154}	
	High idling speed	rpm	2,400 ± 50	
	Low idling speed	rpm	700 ⁺³⁰ ₀	
	Starting motor		24 V 7.5 kW	
Alternator		24 V 75 A		
Battery		12 V 170 Ah × 2		
Power train	Torque converter		3-element, 1-stage, single-phase (Komatsu TCA38-8A)	
	Transmission		Spur gear, constant-mesh multiple-disc, hydraulically actuated, modulation type	
	Reduction gear		Spiral bevel gear, splash lubrication	
	Differential		Straight bevel gear, torque proportioning	
	Final drive		Planetary gear single stage, splash lubrication	

Machine model			WF450-3
Serial No.			54101 and up
Wheels, rims	Drive type		Front-, rear-wheel drive
	Front wheel		Fixed frame, full-floating type
	Rear wheel		Center pin support full-floating type
	Shape of front and rear rims		mm
	Number of feet (per rim)		Piece
Balance capacity (per rim)		l	
Brakes	Service brake		Front-, rear-wheel independent system control, sealed multiple-disc wet-type disc brake With hydraulic booster
	Parking brake		Drive shaft, wet type disc brake Hydraulically released spring type
Steering system	Type		Articulated steering
	Structure		Fully hydraulic power steering
Hydraulic system	Hydraulic pump type		Gear pump
	Delivery	Hydraulic pump	302
		Switch pump	122
		Steering pump	168
		PPC, brake pump	62
Control valve	Set pressure for work equipment		2-spool type 20.6 {210}
	Set pressure for steering		Spool type 20.6 {210}
Cylinder	Boom cylinder No. – bore × stroke		Reciprocating piston 2 – 180 × 764
	Bucket cylinder No. – bore × stroke		Reciprocating piston 1 – 200 × 550
	Steering cylinder No. – bore × stroke		Reciprocating piston 2 – 100 × 440
Work equipment	Link type		Single link
	Bucket edge type		

WF450T-3

Machine model			WF450T-3	
Serial No.			54101 and up	
Weight	Operating weight		kg	
	Distribution (front)		kg	
	Distribution (rear)		kg	
Performance	Travel speed	FORWARD 1st	km/h	6.2
		FORWARD 2nd	km/h	11.0
		FORWARD 3rd	km/h	18.9
		FORWARD 4th	km/h	27.1
		REVERSE 1st	km/h	6.5
		REVERSE 2nd	km/h	11.5
		REVERSE 3rd	km/h	19.8
		REVERSE 4th	km/h	27.3
	Max. rimpull		kN {kg}	211 {21,500}
	Gradeability		deg	25.0
Min. turning radius	Center of outside wheel		mm	
	Outside portion of chassis		mm	
Engine	Model		Komatsu SA6D125E-2	
	Type		4-cycle, water-cooled, in-line, 6-cylinder direct injection, with turbocharger, after-cooler	
	No. of cylinders – bore x stroke		mm	6 – 125 mm x 150 mm
	Piston displacement		l {cc}	11.04 {11,040}
	Flywheel horsepower		kW {HP}/rpm	193.4 {260}/2,200
	Maximum torque		Nm {kgm}/rpm	1,050 {107}/1,400
	Fuel consumption ratio		g/kWh {g/HPH}	207 {154}
	High idling speed		rpm	2,400 ± 50
	Low idling speed		rpm	750 ⁺³⁰ ₀
	Starting motor			24 V 7.5 kW
Alternator			24 V 75 A	
Battery			12 V 170 Ah x 2	
Power train	Torque converter		3-element, 1-stage, single-phase (Komatsu TCA38-8A)	
	Transmission		Spur gear, constant-mesh multiple-disc, hydraulically actuated, modulation type	
	Reduction gear		Spiral bevel gear, splash lubrication	
	Differential		Straight bevel gear, torque proportioning	
	Final drive		Planetary gear single stage, splash lubrication	

Machine model			WF450T-3
Serial No.			54101 and up
Wheels, rims	Drive type		Front-, rear-wheel drive
	Front wheel		Fixed frame, full-floating type
	Rear wheel		Center pin support full-floating type
	Shape of front and rear rims		mm
	Number of feet (per rim)		Piece
Balance capacity (per rim)		l	
Brakes	Service brake		Front-, rear-wheel independent system control, sealed multiple-disc wet-type disc brake With hydraulic booster
	Parking brake		Drive shaft, wet type disc brake Hydraulically released spring type
Steering system	Type		Articulated steering
	Structure		Fully hydraulic power steering
Hydraulic system	Hydraulic pump type		Gear pump
	Delivery	Hydraulic pump	162
		Switch pump	115
		Steering pump	158
		PPC, brake pump	58
Control valve	Set pressure for work equipment	MPa {kg/cm ² }	2-spool type 20.6 {210}
	Set pressure for steering	MPa {kg/cm ² }	Spool type 20.6 {210}
Cylinder	Lift cylinder No. – bore × stroke	mm	Reciprocating piston 1 – 130 × 870
	Steering cylinder No. – bore × stroke	mm	Reciprocating piston 2 – 100 × 440
Dozing equipment	Blade width		mm
	Blade height		mm
	Max. lift above ground		mm
	Max. drop below ground		mm

Weight table



This weight table is a guide for use when transporting or handling components.

Unit: kg

Machine model	WF450-3	WF450T-3
Serial No.	54101 and up	54101 and up
Engine	1150	1150
Radiator	220	220
Transmission (including torque converter)	1000	1000
Center drive shaft	36	36
Front drive shaft	40	40
Rear drive shaft	19	19
Front axle	1482	1445
Rear axle	1493	1470
Front differential	250	250
Rear differential	260	260
Planetary carrier (each)	523	523
Axle pivot (rear axle)	148	148
Rim (1 piece), (triangular foot type)		
Rim (1 piece), (chopper type)		
Steering valve	24	24
Steering cylinder (each)	38	38
Brake (each)	140	140
Hydraulic tank	225	225
Hydraulic, PPC pump (tandem pump)	27	20
Steering, switch pump (tandem pump)	20	20
Main control valve	90	71
Lift cylinder	–	127
Boom cylinder (each)	192	–
Bucket cylinder	222	–
Engine hood	418	418
Front frame	1816	1870
Rear frame	1850	1850
Blade assembly (with cutting edge and end bit)	–	–
Blade	–	–
Bucket link	89	–
Bellcrank	415	–
Boom (including bushing)	1440 × 4	–
Bucket	–	–
Bumper	192	192
Fuel tank	218	218
Battery (each)	47	47
Cab	630	630
Air conditioner unit	12.5	12.5
Operator's seat	–	–
Floor board	272	272

10 STRUCTURE AND FUNCTION

Power train	10-4	Operation of PPC valve [at neutral]	10-97
Torque converter, transmission piping	★	Function of PPC valve	10-98
Torque converter	★	PPC relief valve	★
Transmission	10-14	Accumulator (for PPC valve)	★
Transmission control valve	★	Cut-off valve	10-105
Transmission solenoid valve	10-31	WF450-3	10-105
Pilot oil filter	★	Operation of cut-off valve	10-106
Drive shaft	★	Main control valve	10-107
Axle	10-37	WF450T-3	10-107
Front axle	10-37	WF450-3	10-109
Rear axle	10-38	Main relief valve	10-111
Differential	10-39	Safety valve (with suction)	10-113
Front differential	10-39	Suction valve	10-114
Rear differential	10-39	Float selector valve and unload valve	10-115
Limited slip differential	★	Operation – WF450T-3	10-116
Final drive	10-47	Operation – WF450-3	10-120
Axle mount, center hinge pin	10-49	Bucket positioner and boom kick-out	10-126
Steering piping	10-50	WF450-3	10-126
Steering column	★	Air conditioner	10-131
Steering valve	★	Air conditioner piping	10-131
Orbit-roll valve	★	Machine monitor system	10-132
Stop valve	★	Main monitor	10-133
Brake piping	10-59	Main monitor display function	10-134
Brake valve	★	Main monitor switch function	10-135
Charge valve	★	Preheating output function	10-136
Accumulator (for brake)	★	Trouble data display mode (When optional controller are installed)	10-137
Slack adjuster	★	Maintenance monitor	10-138
Brake	10-77	Maintenance monitor display function	10-139
Parking brake control	★	Sensors	★
Parking brake	10-81	Engine starting circuit	10-148
Parking brake solenoid valve	★	Engine stop circuit	10-149
Parking brake valve	★	Preheating circuit	10-150
Parking brake emergency release solenoid valve	★	(Automatic preheating system)	10-150
Hydraulic component layout	10-89	Electric transmission control	10-152
Work equipment lever linkage	10-90	WF450T-3	10-152
WF450T-3	10-90	WF450-3	10-153
WF450-3	10-91	Combination switch	10-154
Hydraulic tank	10-92	Kick-down switch	10-157
PPC valve	10-93	WF450-3	10-157
WF450T-3	10-93	Kick-down electric circuit diagram	10-158
WF450-3	10-95	WF450-3	10-158
		Transmission cut of switch	★
		Transmission cut of function	★
		Electric parking brake control	★

※ As for structure and function, enter only the special section of WF450 and WF450T-3.
Do not enter the sections common to WA470-3.

※ The sections common to WA470-3 are marked with ★ in the Page No. column on the table of contents. For those sections, see WA470-3 Shop Manual.

Blank for technical reason

Power train

WF450-3

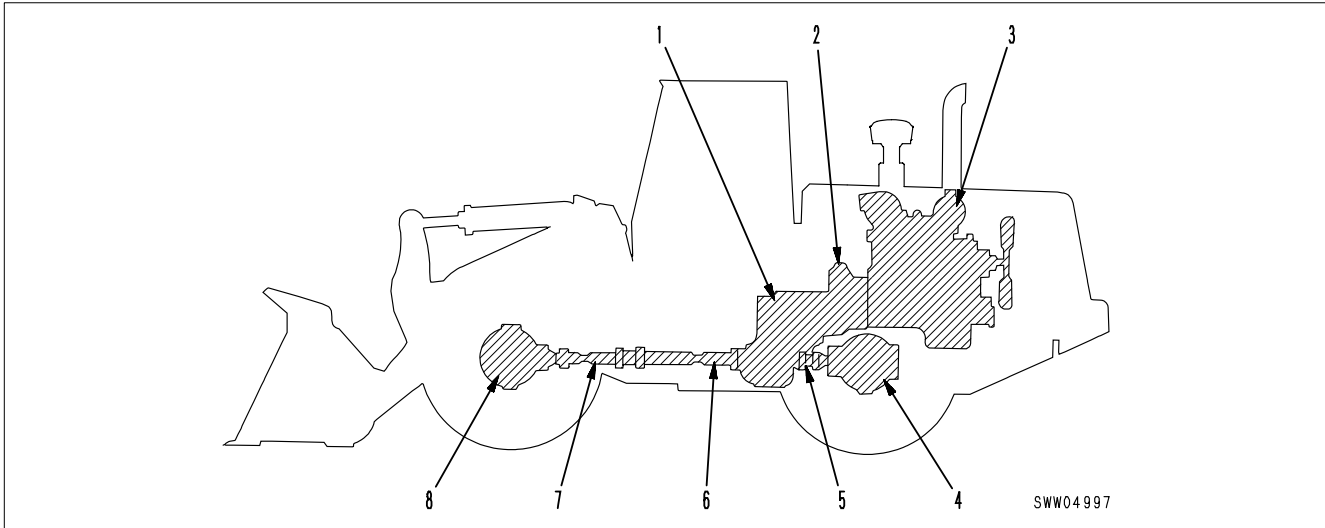

WF450T-3

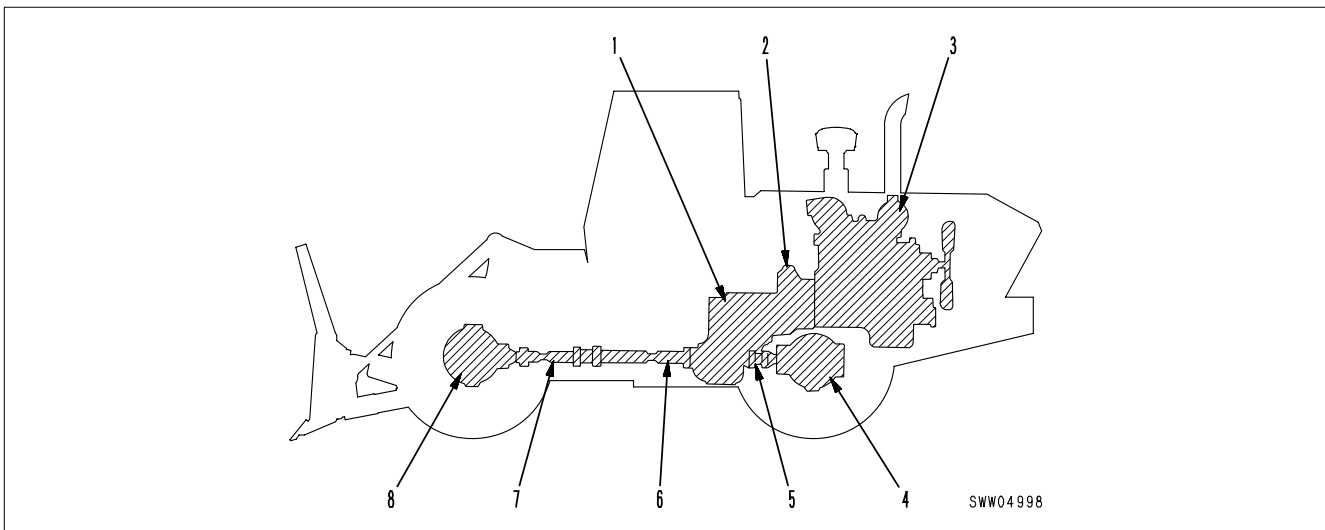

- | | | |
|--|---------------------|-----------------------|
| 1. Transmission
(multiple shaft type) | 3. Engine | 6. Center drive shaft |
| 2. Torque converter | 4. Rear axle | 7. Front drive shaft |
| | 5. Rear drive shaft | 8. Front axle |

Outline

- The motive force from engine (3) passes through the engine flywheel and is transmitted to torque converter (2), which is connected to the input shaft of transmission (1).
- The transmission has six hydraulically actuated clutches, and these provide four speed ranges for both FORWARD and REVERSE.
- The transmission speed ranges are selected manually.
- The motive force from the output shaft of the transmission passes through center drive shaft (6), front drive shaft (7) and rear drive shaft (5), and is then transmitted to front axle (8) and rear axle (4) to drive the wheels.

Pages
10-5 to 10-13
skipped for technical reason

Transmission

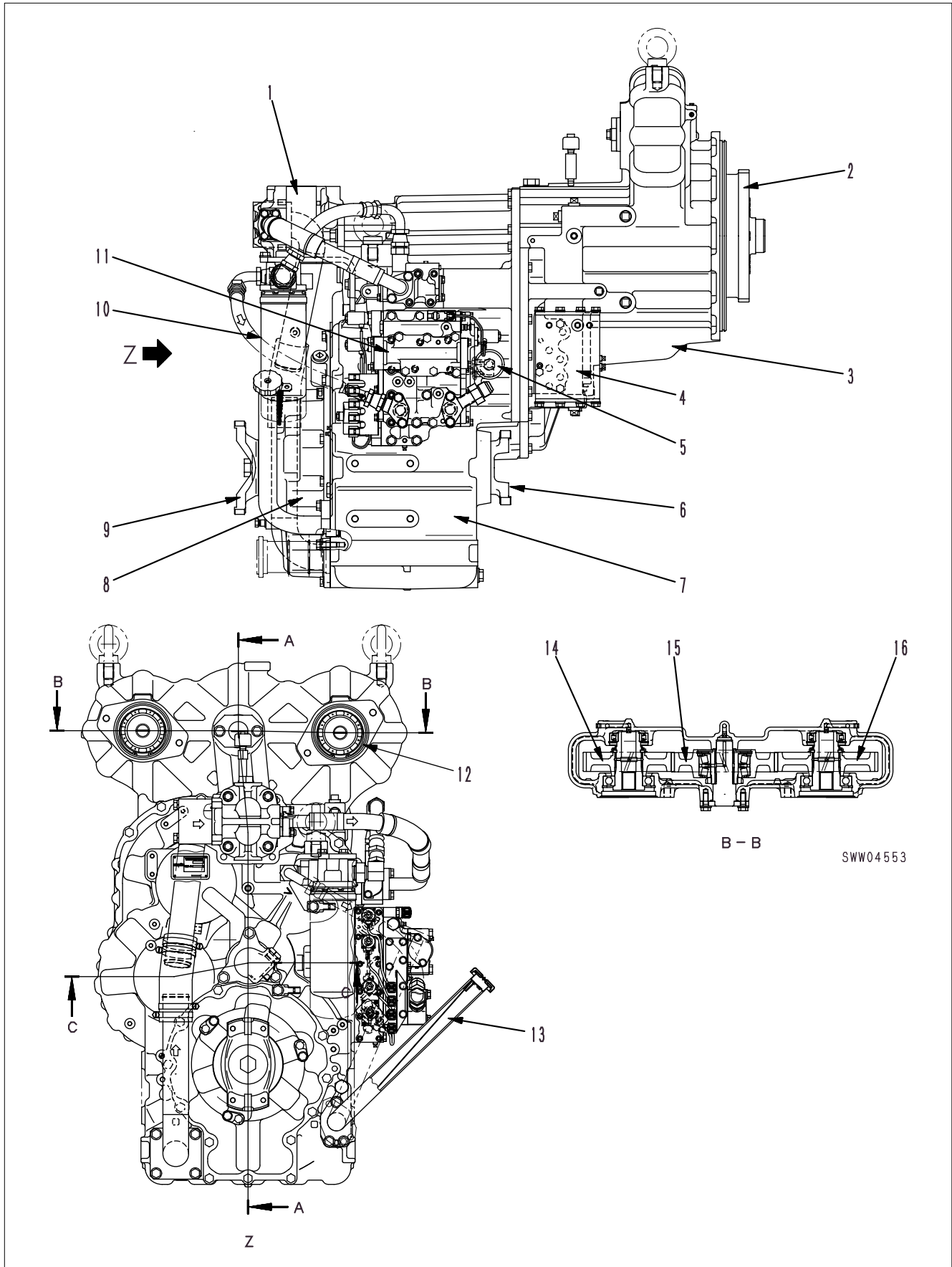

SWW04553

1. Torque converter charging pump
2. Torque converter
3. Torque converter housing
4. Accumulator
5. Oil filter (pilot)
6. Rear output coupling
7. Transmission
8. Parking brake (wet type multiple disc)
9. Front output coupling
10. Oil filter
11. Transmission control valve
12. PTO
13. Transmission oil filler
14. PTO gear (No. of teeth: 65)
15. PTO gear (No. of teeth: 76)
16. PTO gear (No. of teeth: 74)

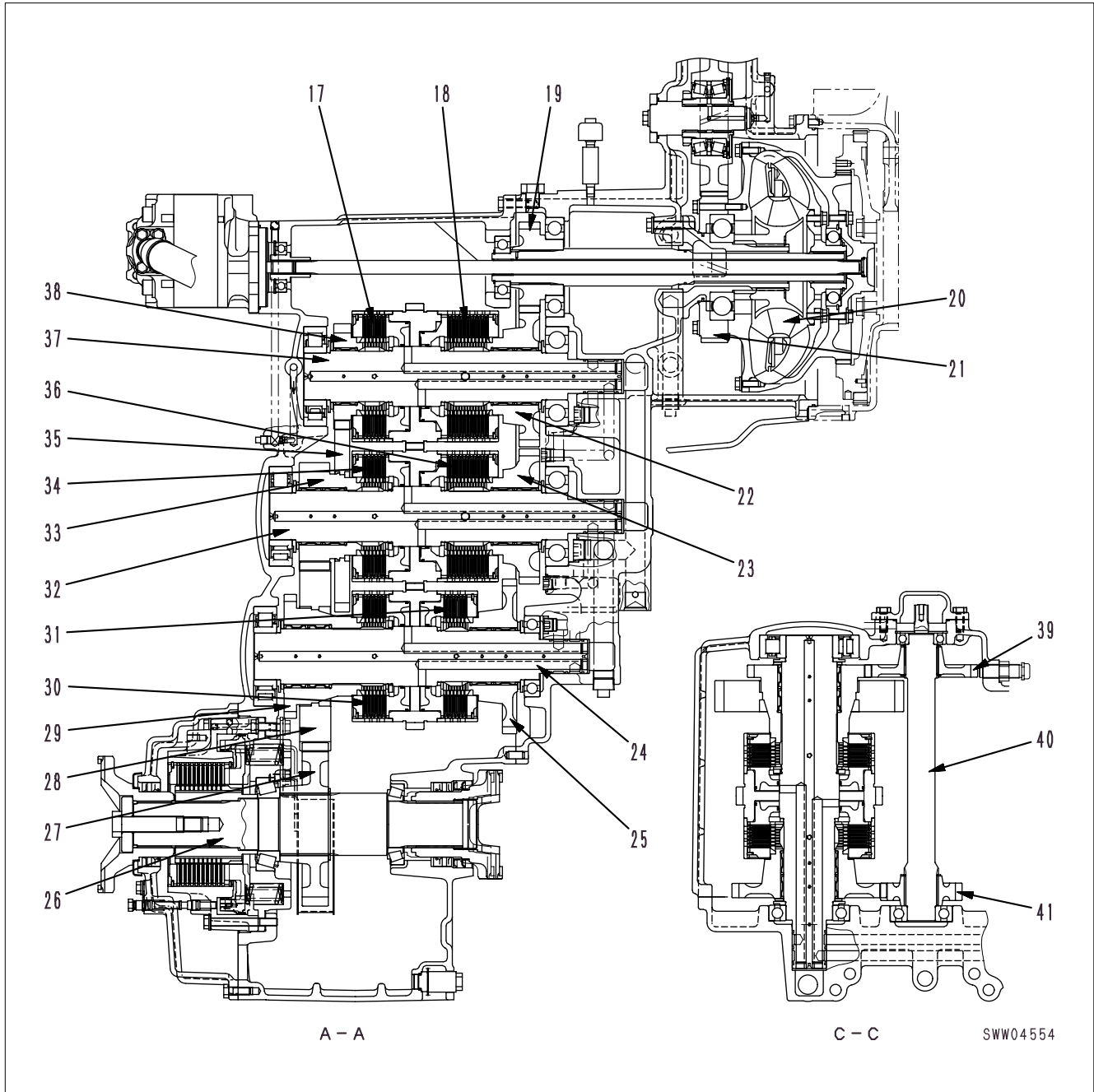

17. 1st clutch
18. FORWARD clutch
19. Input gear (No. of teeth: 30)
20. Torque converter
21. PTO drive gear (No. of teeth: 74)
22. FORWARD gear (No. of teeth: 48)
23. REVERSE gear (No. of teeth: 46)
24. 3rd, 4th shaft (No. of teeth: 50)
25. 4th gear (No. of teeth: 53)
26. Output shaft
27. Output gear (No. of teeth: 41)
28. 3rd gear (No. of teeth: 49)
29. 3rd gear (No. of teeth: 43)
30. 3rd clutch
31. 4th clutch
32. REVERSE, 2nd shaft (No. of teeth: 51)
33. 2nd gear (No. of teeth: 26)
34. 2nd clutch
35. 2nd gear (No. of teeth: 50)
36. REVERSE gear
37. FORWARD, 1st shaft (No. of teeth: 50)
38. 1st gear (No. of teeth: 26)
39. 3rd gear (No. of teeth: 38)
40. Countershaft
41. 4th gear (No. of teeth: 27)

NOTE

For each clutch and explanation of operation, see WA470-3 Shop Manual.

Pages
10-18 to 10-30
skipped for technical reason

Sample of manual. Download All 324 pages at:

<https://www.arepairmanual.com/downloads/2001-komatsu-wf450-3wf450t-3-trash-compactors-service-repair-workshop-manual/>