

Service Manual

Fastrac

3170, 3170 Plus
3190, 3190 Plus
3200, 3200 Plus
3220, 3220 Plus
3230, 3230 Plus

Published by the
TECHNICAL PUBLICATIONS DEPARTMENT
of
JCB SERVICE LTD;
World Parts Centre,
Waterloo Park
Uttoxeter, Staffordshire
ST14 7BS

Publication No. 9803/8030
Issue 9

General Information	1
Care & Safety	2
Routine Maintenance	3
Optional Equipment	A
Body & Framework	B
Electrics	C
Controls	D
Hydraulics	E
Transmission	F
Brakes	G
Steering	H
Suspension	S
Engine	T

Introduction

This publication is designed for the benefit of JCB Distributor Service Engineers who are receiving, or have received, training by JCB Technical Training Department.

These personnel should have a sound knowledge of workshop practice, safety procedures, and general techniques associated with the maintenance and repair of hydraulic earthmoving equipment.

Renewal of oil seals, gaskets, etc., and any component showing obvious signs of wear or damage is expected as a matter of course. It is expected that components will be cleaned and lubricated where appropriate, and that any opened hose or pipe connections will be blanked to prevent excessive loss of hydraulic fluid and ingress of dirt. Finally, please remember above all else

SAFETY MUST COME FIRST!

The manual is compiled in sections, the first three are numbered and contain information as follows:

- 1 = General Information** - includes torque settings and service tools.
- 2 = Care & Safety** - includes warnings and cautions pertinent to aspects of workshop procedures etc.
- 3 = Routine Maintenance** - includes service schedules and recommended lubricants for the whole machine.

The remaining sections are alphabetically coded and deal with Dismantling, Overhaul etc. of specific components, for example:

- A = Optional Equipment**
- B = Body & Framework ...etc**

The page numbering in each alphabetically coded section is not continuous. This allows for the insertion of new items in later issues of the manual.

Section contents, technical data, circuit descriptions, operation descriptions etc. are inserted at the beginning of each alphabetically coded section.

All sections are listed on the front cover; tabbed divider cards align directly with individual sections on the front cover for rapid reference.

Page cross references are generally made by presenting the subject title printed in bold, followed by the title of the section containing the subject. For example:

“**24** If the axle is still on the machine, fit the brake calipers (see **Brake Caliper Removal and Replacement**, Section G).”

Note: If only the subject title in bold is given, i.e. no section title, the cross reference is to another part of the same section.

Use the contents list at the beginning of each section to find the exact page number.

Where a torque setting is given as a single figure it may be varied by plus or minus 3%. Torque figures indicated are for dry threads, hence for lubricated threads may be reduced by one third.

‘Left Hand’ and ‘Right Hand’ are as viewed from the rear of the machine facing forwards.

Contents	Page No.
Machine Identification Plate	1 - 1
Typical Vehicle Identification Number (VIN)	1 - 1
Unit Identification	1 - 1
Torque Settings	
Introduction - Zinc Plated Fasteners and Dacromet Fasteners	2 - 1
Zinc Plated Fasteners	2 - 2
Dacromet Fasteners	2 - 3
Sealing and Retaining Compounds	3 - 1
Service Tools Numerical List	4 - 1
* Service Tools	
Optional Equipment	5 - 0
Body and Framework	5 - 1
Electrics	6 - 1
Hydraulics	7 - 1
Transmission	8 - 1
Brakes	9 - 1
Steering	9 - 1
Suspension	9 - 2
Engine	9 - 2
Moving a Disabled Machine	
General	10 - 1
Preparation for Towing	10 - 1
Transporting the Machine	10 - 2

Serial Number Plate

Each machine has a serial number plate located at **X**. The 17 digit Vehicle Identification Number (VIN), and the serial numbers of the engine and transmission are stamped on the plate.

*** Typical Vehicle Identification No. (VIN)**

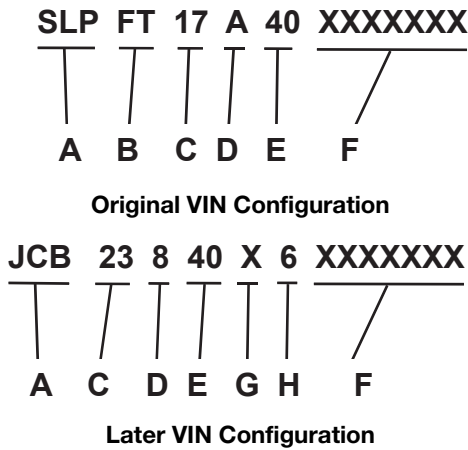

A = Manufacturing Code

B = Machine Range

FT = Fastrac

*** C** = Engine Type

17 = 3190 or 3190 Plus

18 = 3220 or 3220 Plus

19 = 3170 or 3170 Plus

23 = 3200 or 3200 Plus

24 = 3230 or 3230 Plus

*** D** = Transmission Type (Gearbox and axle combination)

3170, 3170 Plus

All other machines

A = 75 km/h

8 = Standard (40, 50 or 65 km/h)

B = 65 km/h

9 = High Speed (75 km/h)

D = 50 km/h

E = 40 km/h

E = Vehicle Max. Speed

40 = 40 km/h

50 = 50 km/h

65 = 65 km/h

75 = 75 km/h

F = Serial Number

*** G** = Authenticity Code

*** H** = year Code (e.g. 6 = 2006)

Unit Identification

The serial number of each major unit is also stamped on the unit itself as shown below. If a major unit is replaced by a new one, the serial number on the plate will be wrong. Either stamp the new number of the unit on the identification plate, or simply stamp out the old number. This will prevent the wrong unit number being quoted when replacement parts are ordered.

Engine

Gearbox Assembly (assembly of all three gearboxes)

Speed Gearbox

Front Axle

Rear Axle

M

N

P

R

S

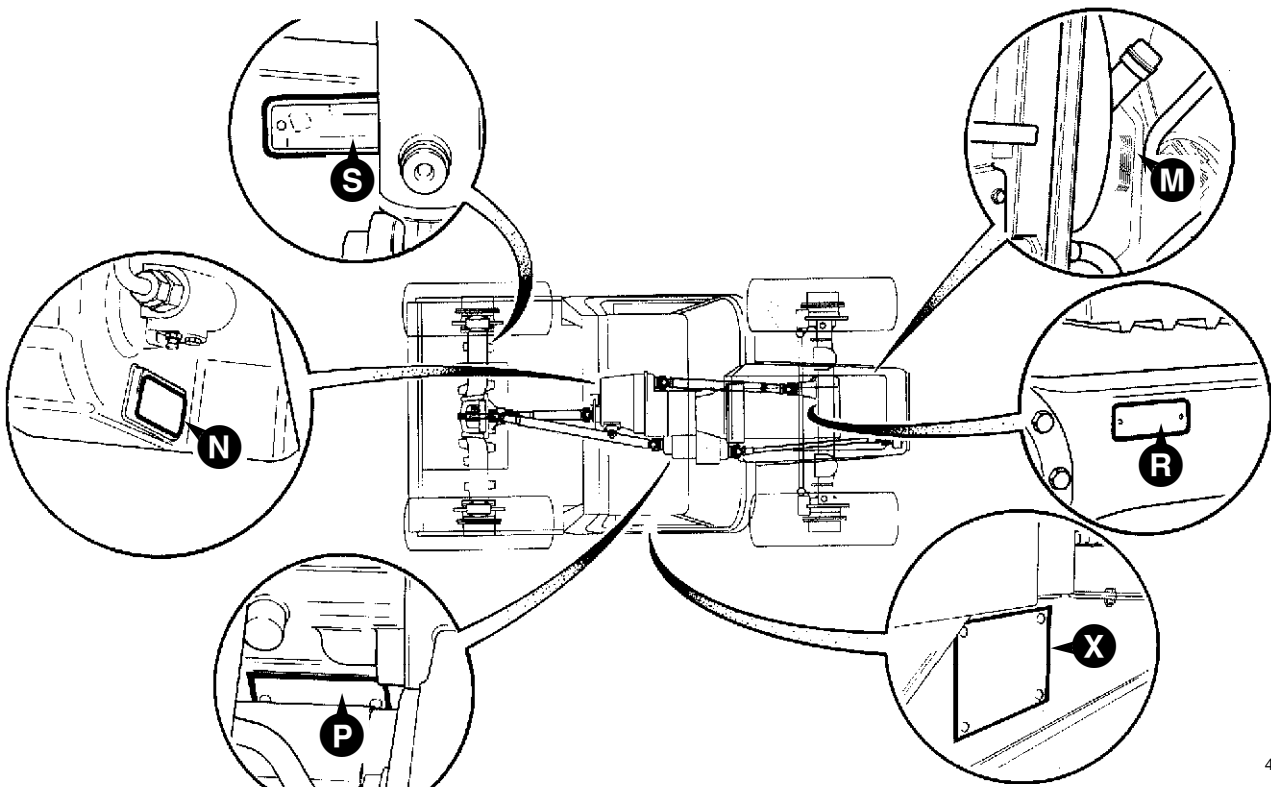

417490

Introduction - Zinc Plated Fasteners and Dacromet Fasteners

Some external fasteners on Fastrac machines are assembled using an improved type of corrosion resistant finish. This type of finish is called Dacromet and replaces the original Zinc and Yellow plating used on earlier machines.

The two types of fasteners can be readily identified by colour and part number suffix as follows:

Fastener Type	Colour	Part Number
Zinc and Yellow	Golden finish	'Z' (e.g. 1315/3712Z)
Dacromet	Mottled silver finish	'D' (e.g. 1315/3712D)

Note: As the Dacromet fasteners have a lower torque setting than the Zinc and Yellow fasteners, the torque figures used must be relevant to the type of fasteners.

Note: A Dacromet bolt should not be used in conjunction with a Zinc and Yellow plated nut, as this could change the torque characteristics of the torque settings further. For the same reason, a Dacromet nut should not be used in conjunction with a Zinc and Yellow plated bolt.

Note: All bolts used on JCB machines are high tensile and must not be replaced by bolts of a lesser tensile specification.

Note: Dacromet bolts, due to their high corrosion resistance are used areas where rust could occur. Dacromet bolts are only used for external applications. They are not used in application such as gearbox and engine joint seams or internal applications.

Zinc Plated Fasteners (golden finish)

Use only where no torque setting is specified in the text. Values are for dry threads and may be within three per cent of the figures stated. For lubricated threads the values should be REDUCED by one third.

Metric Grade 8.8 Bolts

Dia.	Bolt size		Torque Settings		
	(mm)	Hexagon (A/F) mm	Nm	kgf m	lbf ft
M5	(5)	8	7	0.7	5
M6	(6)	10	12	1.2	9
M8	(8)	13	28	3.0	21
M10	(10)	17	56	5.7	42
M12	(12)	19	98	10	72
M16	(16)	24	244	25	180
M18	(18)	27	350	36	258
M20	(20)	30	476	48	352
M24	(24)	36	822	84	607
M30	(30)	46	1633	166	1205
M36	(36)	55	2854	291	2105

Metric - All Internal Hexagon Headed Cap Screws

Diameter mm	Torque		
	Nm	kgf m	lbf ft
M3	2	0.2	1.5
M4	6	0.6	4.5
M5	11	1.1	8
M6	19	1.9	14
M8	46	4.7	34
M10	91	9.3	67
M12	159	16.2	117
M16	395	40	292
M18	550	56	406
M20	770	79	568
M24	1332	136	983

Metric Grade 10.9 Bolts

Dia.	Bolt size		Torque Settings		
	(mm)	Hexagon (A/F) mm	Nm	kgf m	lbf ft
M6	(6)	8	16	1.6	12
M8	(8)	13	39	4	29
M10	(10)	17	78	8	57
M12	(12)	19	137	14	101
M16	(16)	24	343	35	253
M20	(20)	30	657	67	485
M24	(24)	36	1157	118	853

Verbus Ripp Bolts

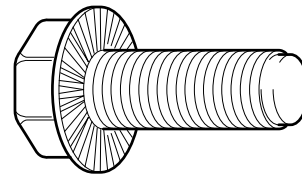

A343780

Torque settings for these bolts are determined by the application. Refer to the relevant procedure for the required settings.

Hydraulic Hose to Adapter Connections

BSP Size (inches)	Torque Settings		
	Nm	kgf m	lbf ft
1/8	14	1.4	10
1/4	24	2.5	18
3/8	33	3.3	24
1/2	44	4.8	35
5/8	58	6.0	43
3/4	84	8.6	62
1	115	11.8	85
1 1/2	244	24.9	180

Hydraulic Adapter into Component Connections with bonded washers

BSP Size (inches)	Torque Settings		
	Nm	kgf m	lbf ft
1/8	20	2.1	15
1/4	34	3.4	25
3/8	75	7.6	55
1/2	102	10.3	75
5/8	122	12.4	90
3/4	183	18.7	135
1	203	20.7	150
1 1/2	305	31	225

Dacromet Fasteners (mottled silver finish)

Use only where no torque setting is specified in the text.

NOTE: DACROMET FASTENERS ARE LUBRICATED AS PART OF THE PLATING PROCESS: DO NOT LUBRICATE.

Metric Grade 8.8 Bolts

Bolt size Dia.	Torque Settings		
	Nm	kgf m	lbf ft
M6 x 1.0	9	0.9	7
M8 x 1.25	22.5	2.3	17
M10 x 1.5	47.5	4.8	35
M12 x 1.75	80	8.2	59
M14 x 2	133	13.6	98
M16 x 2	200	20.4	148
M18 x 2.5	278	28.4	205
M20 x 2.5	392	40	289
M24 x 3	675	69	498
M30 x 3.5	1348	138	994

Metric Grade 10.9 Bolts

Bolt size Dia.	Torque Settings		
	Nm	kgf m	lbf ft
M6 x 1.0	13.5	1.4	10
M8 x 1.25	35	3.6	26
M10 x 1.5	62.5	6.4	46
M12 x 1.75	115	11.7	85
M14 x 2	175	17.9	129
M16 x 2	300	30.6	221
M18 x 2.5	395	40	291
M20 x 2.5	559	57	412
M24 x 3	962	98	710
M30 x 3.5	1920	196	1416

Metric Grade 12.9 Bolts

Bolt size Dia.	Torque Settings		
	Nm	kgf m	lbf ft
M6 x 1.0	15	1.5	11
M8 x 1.25	40	4.1	29
M10 x 1.5	80	8.2	59
M12 x 1.75	133	13.6	98
M14 x 2	225	23	166
M16 x 2	350	35.7	258
M18 x 2.5	463	47	342
M20 x 2.5	654	67	482
M24 x 3	1125	115	830
M30 x 3.5	2247	229	1657

Dacromet Fasteners (mottled silver finish) - List of Torque Settings

This list shows Dacromet fasteners that may not be shown in the other sections of the service manual.

Location: Front Wrapper
(top/bottom)
Nm: 392 **kgf m:** 40 **lbf ft:** 289

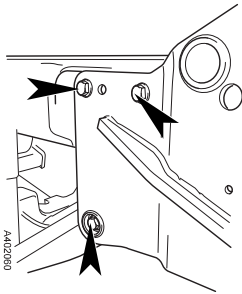

Location: Front Lower Crossmember
Nm: 115 **kgf m:** 12 **lbf ft:** 85

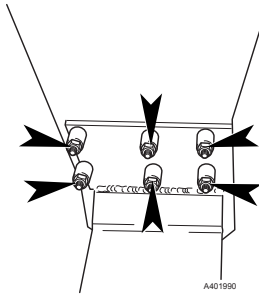

Location: Front P.T.O. Box
Nm: 200 **kgf m:** 20 **lbf ft:** 148

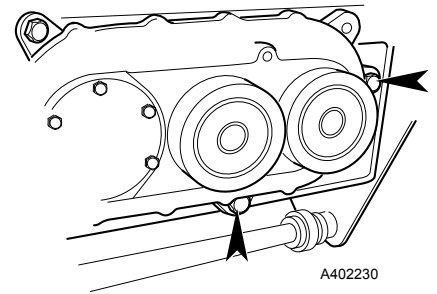

* **Location:** Front Axle Upper Arm
Mounting Bracket
8.8 grade bolts:
Nm: 200 **kgf m:** 20 **lbf ft:** 148

**10.9 grade bolts (all bolts with JCB
Threadlocker and Sealer and with
spacer fitted at bolt B):**
Nm: 300 **kgf m:** 30 **lbf ft:** 220

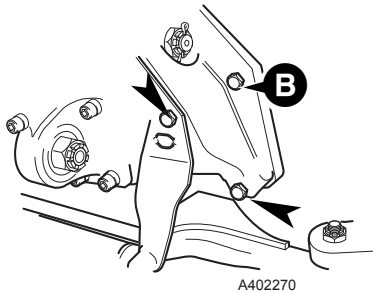

Location: Front Engine Mounting
Nm: 200 **kgf m:** 20 **lbf ft:** 148

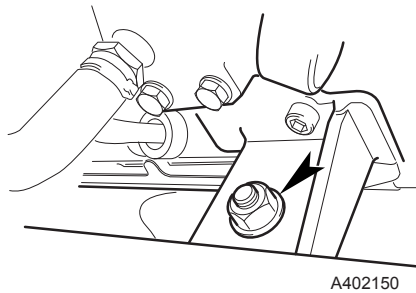

Location: Header Tank Clamp Plate
Nm: 30 **kgf m:** 3 **lbf ft:** 22

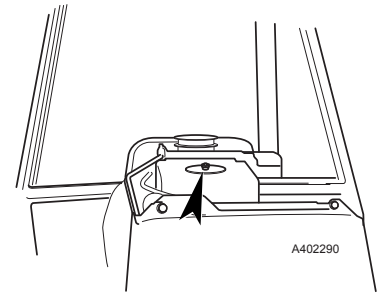

Location: Steershaft Bearing
Nm: 28 **kgf m:** 2.9 **lbf ft:** 21

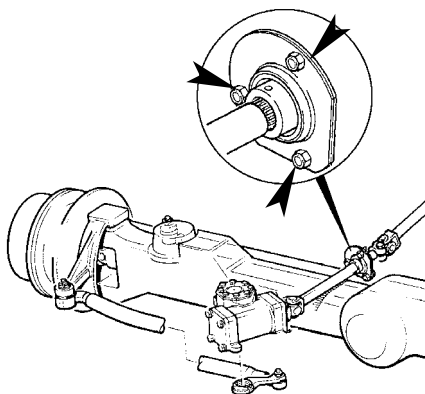

Location: Steershaft upper UJ
Nm: 38 **kgf m:** 3.9 **lbf ft:** 28

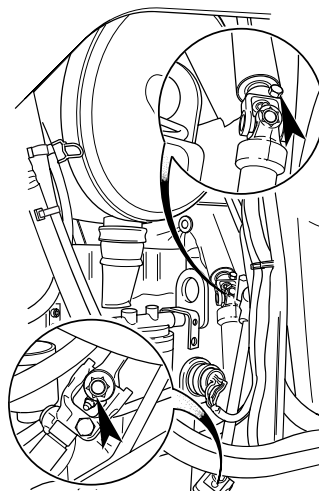

Dacromet Fasteners (mottled silver finish) - List of Torque Settings (continued)

Location: Gearbox Crossmember
Nm: 200 **kgf m:** 20 **lbf ft:** 148

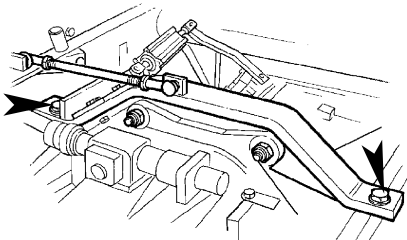

Location: Left Hand Pannier Step
Nm: 47.5 **kgf m:** 4.8 **lbf ft:** 35

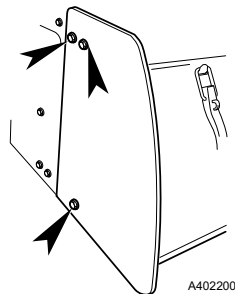

Location: Rear Anti-Roll bar mounting bracket
Nm: 392 **kgf m:** 40 **lbf ft:** 289

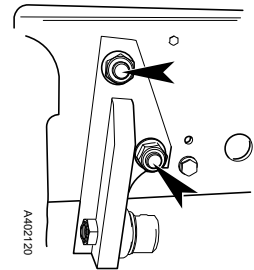

Location: Tower Casting to Axle
Nm: 392 **kgf m:** 40 **lbf ft:** 289

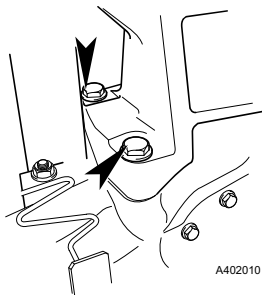

Location: Lower Link Capscrew
Nm: 654 **kgf m:** 67 **lbf ft:** 482

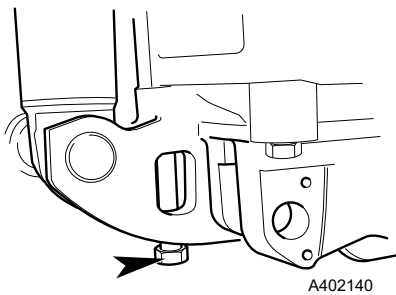

Location: Lower Link Bolt (Hex Head)
Nm: 392 **kgf m:** 40 **lbf ft:** 289

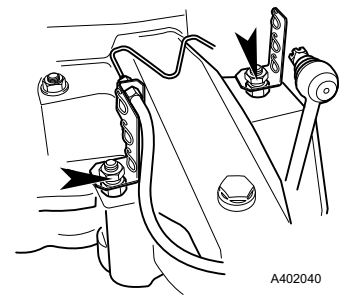

Location: Rear Crossmember
Nm: 392 **kgf m:** 40 **lbf ft:** 289

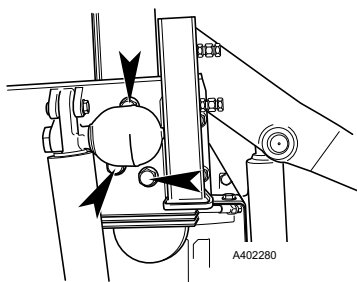

Location: Rear Lower Crossmember
Nm: 200 **kgf m:** 20 **lbf ft:** 148

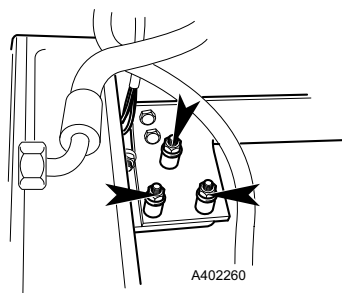

Location: Rockinger Hitch Bolt
Nm: 392 **kgf m:** 40 **lbf ft:** 289

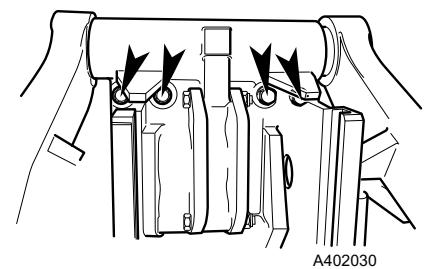

Sealing and Retaining Compounds

* Gasketing - Loctite 509	To seal the joint faces between the PTO/splitter gearbox, the speed gearbox and the range gearbox.	4102/3202 4102/3240	50ml 315 ml
JCB Multigasket	A medium strength sealant suitable for all sizes of gasket flanges, and for hydraulic fittings of 25-65 mm diameter.	4102/1212	
JCB High Strength Threadlocker	A high strength locking fluid for use with threaded components. Gasketing for all sizes of flange where the strength of the joint is important.	4102/0551	
JCB Retainer (High Strength)	For all retaining parts which are unlikely to be dismantled.	4101/0651	
JCB Threadlocker & Sealer	A medium strength locking fluid for sealing and retaining nuts, bolts, and screws up to 50 mm diameter, and for hydraulic fittings up to 25 mm diameter.	4101/0251	
JCB Threadlocker	For threads of suction strainer.	4101/0451	50ml
JCB Threadlocker & Sealer (High Strength)	A medium to high strength locking fluid.	4101/0552	
JCB Threadseal	Medium strength thread sealant (for patch bolts that are re-used).	4102/1951	50 ml
Clayton System Seal SC1251	A thread sealant used mainly on air brake system hose adapters.	4102/2210	2ml
JCB Activator	A cleaning primer which speeds the curing rate of anaerobic products.	4104/0251 4104/0253	Aerosol Bottle
JCB Cleaner/Degreaser	For degreasing components prior to use of anaerobic adhesives and sealants.	4104/1557	Aerosol
Direct Glazing Kit	For one pane of glass, comprises items marked † below plus applicator nozzle etc.	993/55700	
† Ultra Fast Adhesive	For direct glazing	4103/2109	310 ml
† Active Wipe 205	For direct glazing	4104/1203 4104/1206	250 g 30 ml
† Black Primer 206J	For direct glazing	4201/4906	30 ml
JCB Clear Silicone Sealant	To seal butt jointed glass. Also to seal hub planet gear carrier when no 'O' ring is fitted	4102/0901	
Black Polyurethane Sealant	To finish exposed edges of laminated glass	4102/2309	310 ml

Service Tools Numerical List

		Page No.			
			892/00278	Gauge 0 - 40 bar	7 - 2
			892/00279	Gauge 0 - 400 bar	7 - 2
			892/00281	Avo Meter	6 - 1
			892/00282	Shunt	6 - 1
			892/00283	Tool Kit Case	6 - 1
			892/00284	Digital Tachometer	6 - 1
			892/00285	Oil Temperature Probe	6 - 1
			892/00286	Surface Temperature Probe	6 - 1
			892/00293	Connector Pipe	7 - 1
			892/00294	Connector Pipe	7 - 1
			892/00298	Fluke Multimeter	6 - 1
			892/00311	Brake Test Kit	8 - 4
			892/00312	Dummy End Plate	8 - 2
			892/00314	Accumulator Adapter	9 - 1
			892/00318	Hose and Adapter Kit	7 - 2
			892/00333	Heavy Duty Socket, 19 mm A/F	8 - 2
			892/00334	Gland Seal Fitting Tool	7 - 2
			892/00706	Test Probe	7 - 2
			892/00801	Clutch spanner	5 - 3
			892/00802	Rotor puller set	5 - 3
			892/00803	Rotor installer set	5 - 3
			892/00807	Front plate puller	5 - 3
			892/00808	Shaft protector	5 - 3
			892/00812	Drive Coupling Spanner	8 - 1
			892/00817	Heavy Duty Socket, 17 mm A/F	8 - 2
			892/00818	Heavy Duty Socket, 22mm A/F	8 - 2
			892/00819	Heavy Duty Socket, 15 mm A/F	8 - 2
			892/00842	Glass Lifter	5 - 1
			892/00843	Folding Stand	5 - 1
			892/00844	Long Knife	5 - 2
			892/00845	Cartridge Gun	5 - 1
			892/00846	Glass Extractor Handles	5 - 2
			892/00847	Nylon Spatula	5 - 3
			892/00848	Wire Starter	5 - 2
			892/00849	Braided Cutting Wire	5 - 2
			892/00864	PD 90 Axle Locknut Spanner	8 - 3
			892/00871	Frame (Puller Adapter Assembly)	9 - 1
			892/00874	Brace (Puller Adapter Assembly)	9 - 1
			892/00875	Bar M24 (Puller Adapter Assembly)	9 - 1
			892/00876	Block (Puller Adapter Assembly)	9 - 1
			892/00892	Speed Gearbox Locking Tool	8 - 3
			892/00916	Spring Compressor	8 - 3
			892/00918	Setting Tool Kit	8 - 3
			892/00945	Sleeve for M30 Pinion	8 - 3
			892/01033	Data Link Adapter Kit - ABS	6 - 1
			892/01045	Peg Socket - Wet Clutch	8 - 5
			892/01046	Mandrel - Wet Clutch	8 - 4
			892/01047	Jig - Wet Clutch	8 - 4
			892/01048	Clutch Pack Retainer - Wet Clutch (2 required)	8 - 4
			892/01049	Guide Rod - Wet Clutch (2 required)	8 - 4
			892/01050	Mandrel - Wet Clutch	8 - 4
			892/01051	Intermediate Gear Retaining Tool - Wet Clutch Transmission	8 - 4
			892/01052	Locking Plate - Wet Clutch (2 required)	8 - 4
			892/01053	Adapter for impulse extractor (PTO intermediate shaft, wet clutch transmission)	8 - 2
			892/01066	Combination Lead	6 - 2
			* 892/01092	Wheel Hub Service Kit	8 - 5
			926/15500	Rubber Spacer Blocks	5 - 3
			992/09000	Peg Spanner	5 - 0
			992/12300	Mobile Oven	5 - 1
			992/12400	Static Oven	5 - 1

Service Tools Numerical List (continued)

		Page No.
992/12600	Static Oven	5 - 1
992/12800	Cut-out Knife	5 - 2
992/12801	'L' Blades	5 - 2
993/45400	Torque Multiplier	8 - 1
993/55700	Direct Glazing Kit	3 - 1
993/59300	Pressure Test Adapter and Clamp	8 - 2
993/69800	Seal Kit	7 - 1
993/70111	Break-back Torque Wrench	8 - 3
997/11000	Drive Head Setting Bracket	8 - 3
997/11100	Adapter for M24 Pinion	8 - 3

The following parts are replacement items for kits and would normally be included in the relevant kit numbers.

Replacement items for kit no. 892/00253

892/00201	Gauge 0 - 20 bar	7 - 1
892/00202	Gauge 0 - 40 bar	7 - 1
892/00203	Gauge 0 - 400 bar	7 - 1
892/00254	Hose	7 - 1

*** Replacement parts for kit no. 892/01092**

1315/3414Z	Bolt M10x60	8 - 5
1315/3731Z	Bolt M16x220	8 - 5
1315/3835Z	Bolt M20x300	8 - 5
1370/0301Z	Nut M10	8 - 5
1370/0401Z	Nut M12	8 - 5
1370/0601Z	Nut M16	8 - 5
1370/0701Z	Nut M20	8 - 5
1420/0009Z	Washer M12	8 - 5
1420/0012Z	Washer M20	8 - 5
445/12303	Washer	8 - 5
892/00891	Dolly	8 - 5
917/02800	Bearing	8 - 5
998/10606	Bearing Fitting Tube	8 - 5
998/10607	Inner Bearing Plate	8 - 5
998/10608	Bearing Centre Puller	8 - 5
998/10610	Puller Rod	8 - 5
998/10614	Reaction Tube	8 - 5
998/10615	Wheel Bearing Carrier Puller	8 - 5
998/10616	Puller Handle Nut	8 - 5
998/10623	Puller Beam	8 - 5
998/10624	Modified Wheel Stud	8 - 5

Service Tools

Section A - Optional Equipment

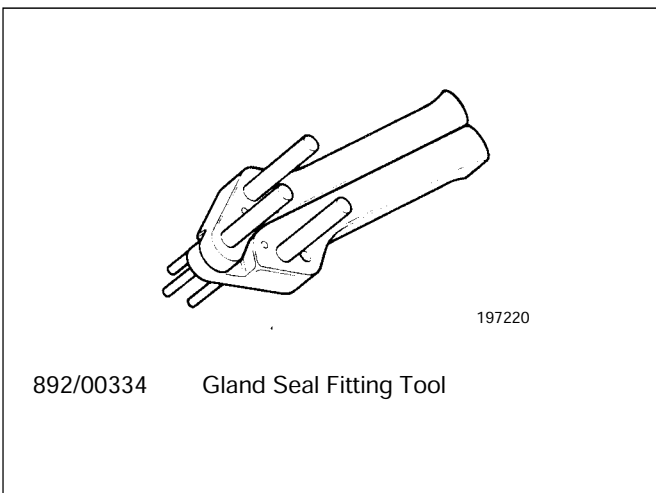
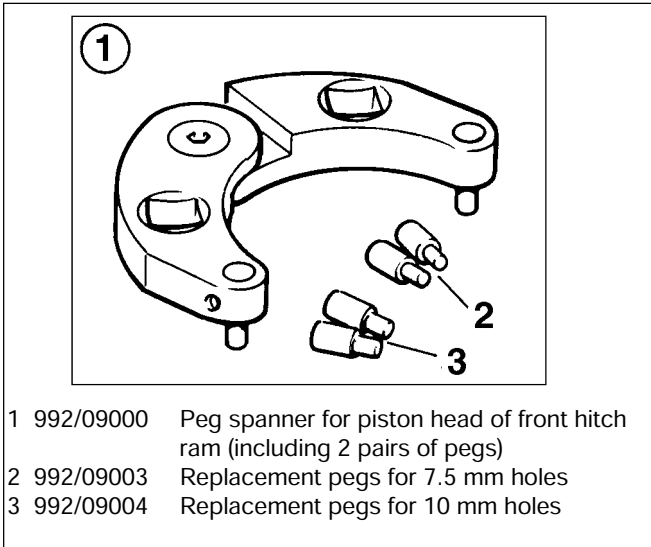

Service Tools

Section B - Body and Framework

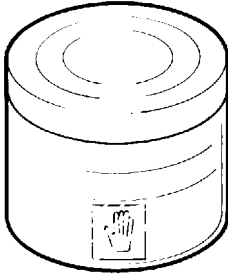

S186240

Hand Cleaner - special blend for the removal of polyurethane adhesives.

JCB part number - 4104/1310 (454g; 1lb tub)

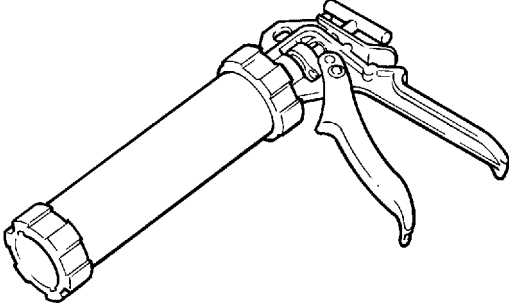

S186270

Cartridge Gun - hand operated - essential for the application of sealants, polyurethane materials etc.

JCB part number - 892/00845

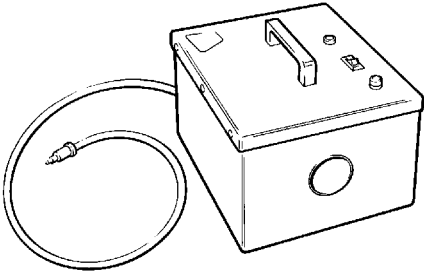

S186250

12V Mobile Oven - 1 cartridge capacity - required to pre-heat adhesive prior to use. It is fitted with a male plug (703/23201) which fits into a female socket (715/04300).

JCB part number - 992/12300

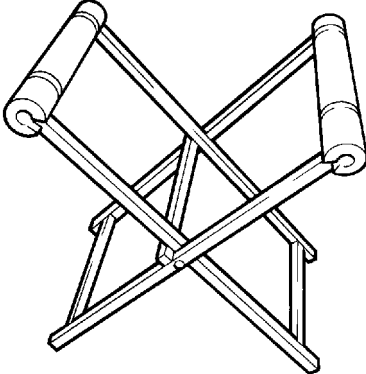

S186280

Folding Stand for Holding Glass - essential for preparing new glass prior to installation.

JCB part number - 892/00843

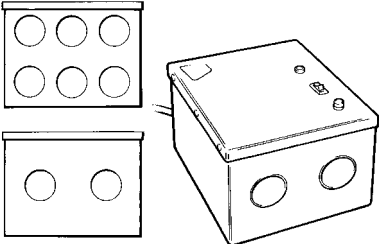

S186260

240V Static Oven - available with 2 or 6 cartridge capacity - required to pre-heat adhesive prior to use. No plug supplied. Note: 110V models available upon request - contact JCB Technical Service

JCB part number:
 992/12400 - 2 cartridge x 240V
 992/12600 - 6 cartridge x 240V

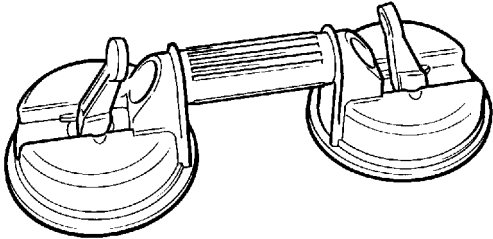

S186300

Glass Lifter - minimum 2 off - essential for glass installation, 2 required to handle large panes of glass. Ensure suction cups are protected from damage during storage.

JCB part number - 892/00842

Service Tools (continued)

Section B - Body and Framework (continued)

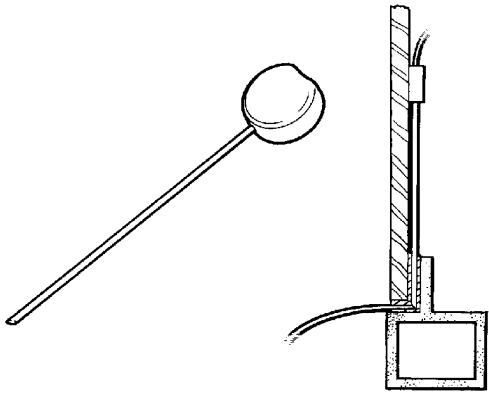

S186310

Wire Starter - used to access braided cutting wire (below) through original polyurethane seal.

JCB part number - 892/00848

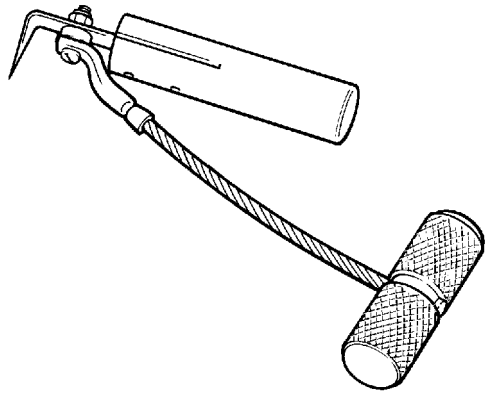

S186340

Cut-out Knife - used to remove broken glass.

JCB part number - 992/12800

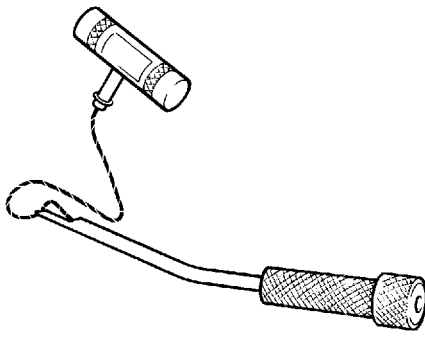

S186320

Glass Extractor (Handles) - used with braided cutting wire (below) to cut out broken glass.

JCB part number - 892/00846

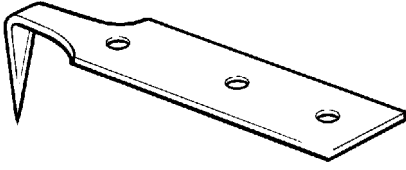

S186350

'L' Blades - 25mm (1in.) cut - replacement blades for cut-out knife (above).

JCB part number - 992/12801 (unit quantity = 5 off)

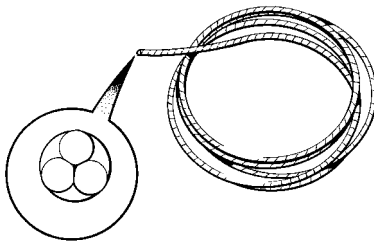

S186330

Braided Cutting Wire - consumable heavy duty cut-out wire used with the glass extraction tool (above).

JCB part number - 892/00849 (approx 25m length)

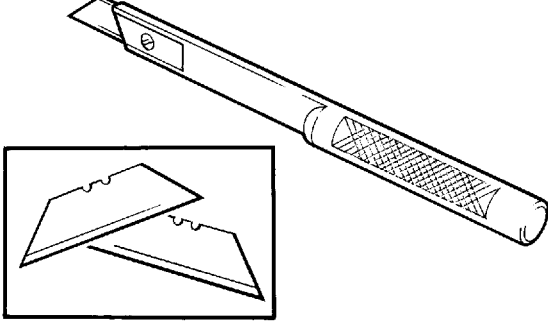

S186360

Long Knife - used to give extended reach for normally inaccessible areas.

JCB part number - 892/00844

Service Tools (continued)

Section B - Body and Framework (continued)

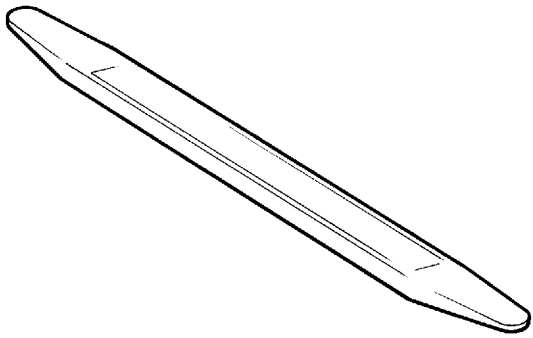

Nylon Spatula - general tool used for smoothing sealants - also used to re-install glass in rubber glazing because metal tools will chip the glass edge.

JCB part number - 892/00847

S186470

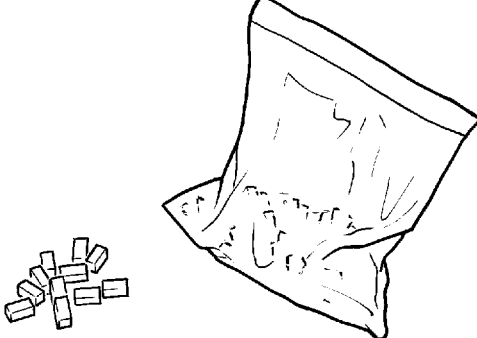

Rubber Spacer Blocks - used to provide the correct set clearance between glass edge and cab frame.

JCB part number - 926/15500
(unit quantity = 500 off)

S186550

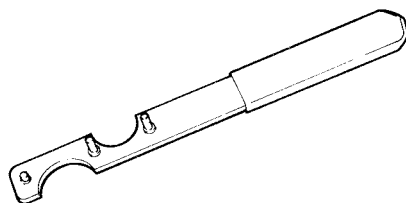

892/00801 Clutch spanner for air conditioning compressor

S200940

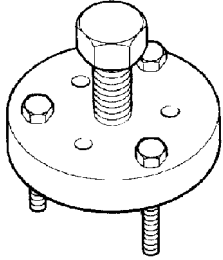

892/00807 Front plate puller for air conditioning compressor

S200970

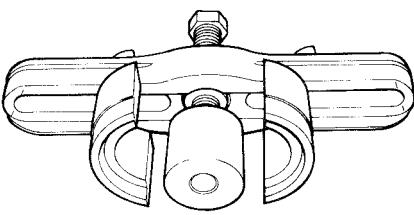

892/00802 Rotor puller set for air conditioning compressor

S200950



892/00808 Shaft protector for air conditioning compressor

S200980

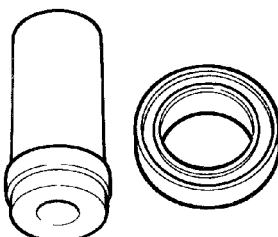

892/00803 Rotor installer set for air conditioning compressor

S200960

Service Tools

Section C - Electrics

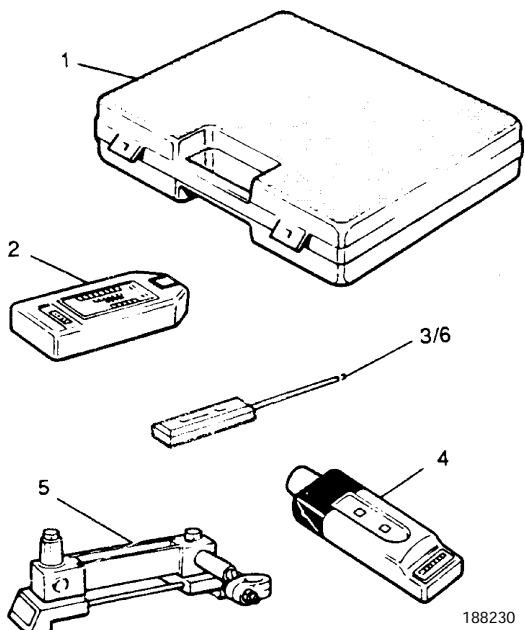

Electrical Test Equipment

- 1 892/00283 Tool Kit Case
- 2 892/00281 AVO Meter
- 3 892/00286 Surface Temperature Probe
- 4 892/00284 Microtach Digital Tachometer
- 5 892/00282 100 Amp Shunt - open type
- 6 892/00285 Hydraulic Oil Temperature Probe
- 7 892/00298 Fluke 85 Multimeter

188230

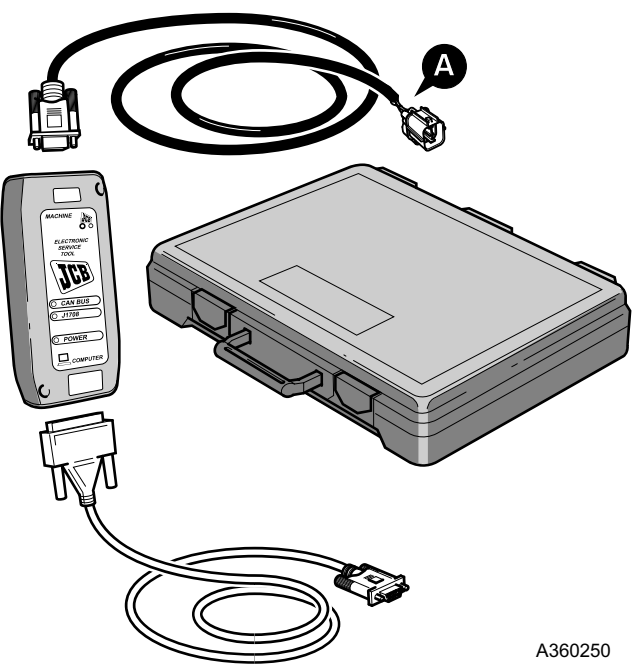

892/01033 Data Link Adapter Kit - ABS

Note: Item **A** of the Data Link Adapter Kit is unsuitable for use with the Fastrac and must be replaced by the 'Harness - Diagnostic (J1939)' shown below.

A360250

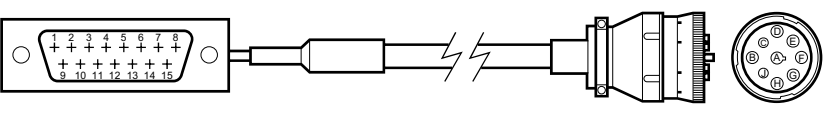

A386040

* 721/10885 Harness - Diagnostic (J1939)

Service Tools (continued)

Section C - Electrics (continued)

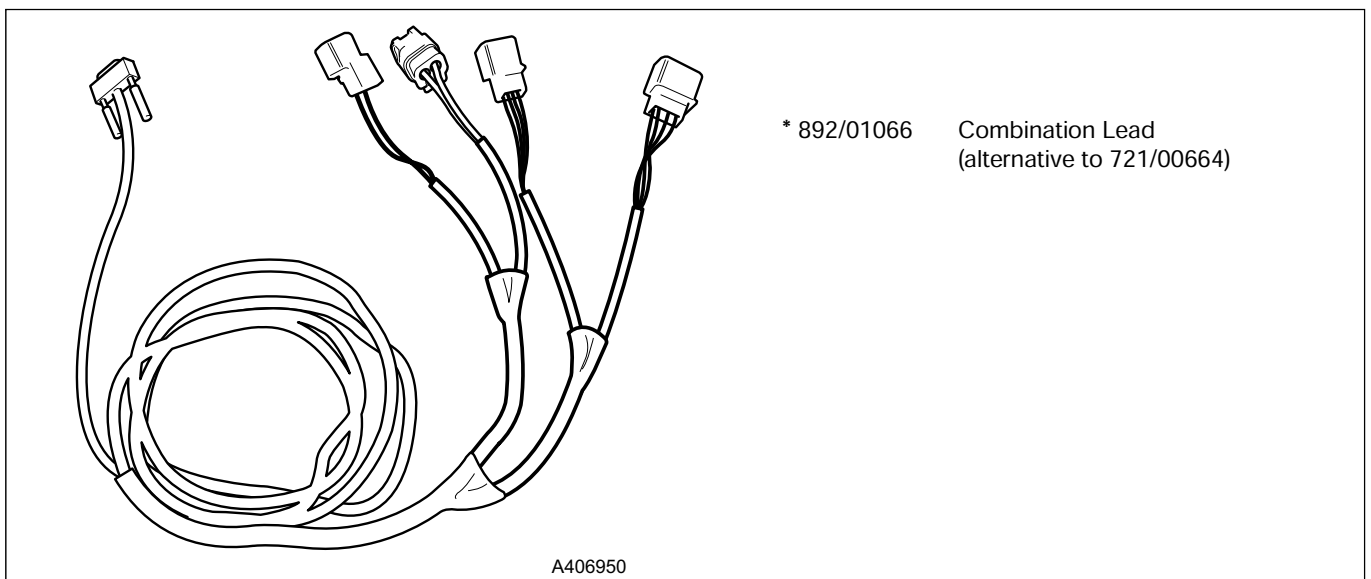
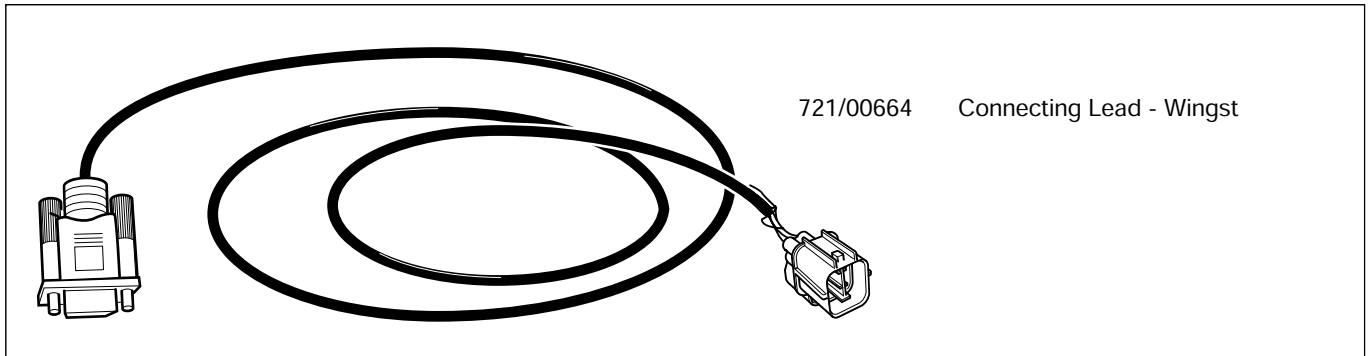

Service Tools

Section E - Hydraulics

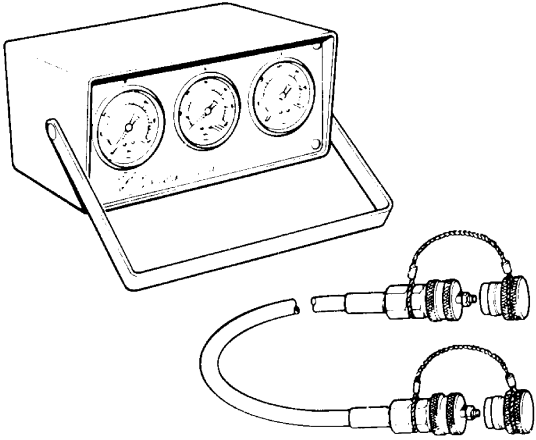

Hydraulic Circuit Pressure Test Kit

892/00253	Pressure Test Kit
892/00201	Replacement Gauge 0-20 bar (0-300 lbf/in ²)
892/00202	Replacement Gauge 0-40 bar (0-600 lbf/in ²)
892/00203	Replacement Gauge 0-400 bar (0-6000 lbf/in ²)
892/00254	Replacement Hose
:993/69800	Seal Kit for 892/00254 (can also be used with probe 892/00706)

S188120

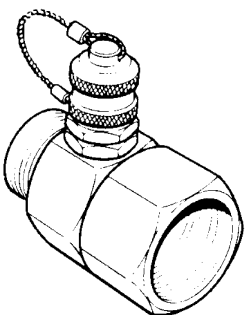

Pressure Test 'T' Adapters

892/00262	1/4 in M BSP x 1/4 in F BSP x Test Point
816/55038	3/8 in M BSP x 3/8 in F BSP x Test Point
816/55040	1/2 in M BSP x 1/2 in F BSP x Test Point
892/00263	5/8 in M BSP x 5/8 in F BSP x Test Point
892/00264	3/4 in M BSP x 3/4 in F BSP x Test Point
892/00265	1 in M BSP x 1 in F BSP x Test Point

S188130

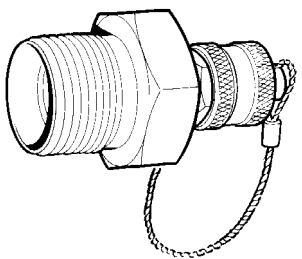

Pressure Test Adapters

892/00255	1/4 in BSP x Test Point
892/00256	3/8 in BSP x Test Point
892/00257	1/2 in BSP x Test Point
892/00258	5/8 in BSP x Test Point
816/15118	3/4 in BSP x Test Point
892/00259	1 in BSP x Test Point
892/00260	1.1/4 in BSP x Test Point
892/00261	5/8 in UNF x Test Point

S200140

Flow Test Equipment

892/00268	Flow Monitoring Unit
892/00269	Sensor Head 0 - 100 l/min (0 - 22 UK gal/min)
892/00293	Connector Pipe
892/00270	Load Valve
1406/0021	Bonded Washer
1604/0006	Adapter 3/4 in M x 3/4 in M BSP
1612/0006	Adapter 3/4 in F x 3/4 in M BSP
892/00271	Adapter 3/4 in F x 5/8 in M BSP
892/00272	Adapter 5/8 in F x 3/4 in M BSP
816/20008	Adapter 3/4 in F x 1/2 in M BSP
892/00275	Adapter 1/2 in F x 3/4 in M BSP
892/00276	Adapter 3/4 in F x 3/8 in M BSP
892/00277	Adapter 3/8 in F x 3/4 in M BSP
892/00273	Sensor Head 0 - 380 l/min
892/00294	Connector Pipe
1606/0015	Adapter 1.1/4 in M BSP x 1 in M BSP
892/00078	Connector 1 in F x 1 in F BSP
1604/0008	Adapter 1 in M x 1 in M BSP
1606/0012	Adapter 1 in M x 3/4 in M BSP
816/20013	Adapter 3/4 in F x 1 in M BSP

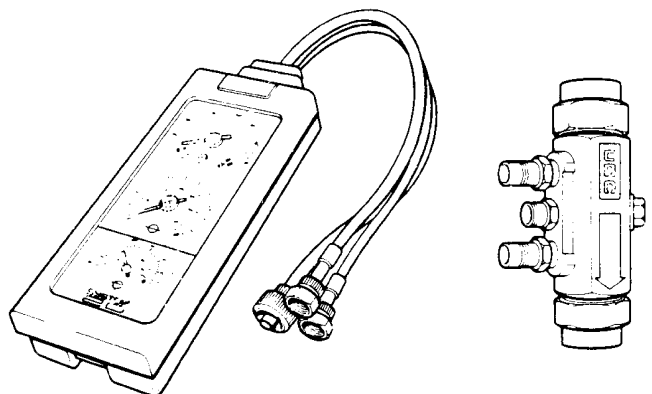

S188150

Service Tools (continued)

Section E - Hydraulics (continued)

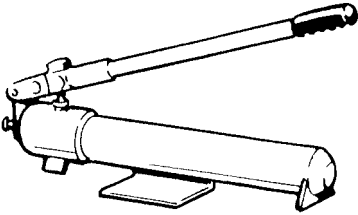

S193850

Hand Pump Equipment

- 892/00223 Hand Pump
- 892/00137 Micro-bore Hose 1/4 in BSP x 5 metres
- 892/00274 Adapter 1/4 in BSP male x 3/8 BSPT male
- 892/00262 Test Point on 1/4 in BSP male x 1/4 BSP female adapter
- 892/00706 Test Probe
- 892/00278 Gauge 0-40 bar (0-600 lbf/in²)
- 892/00279 Gauge 0-400 bar (0-6000 lbf/in²)

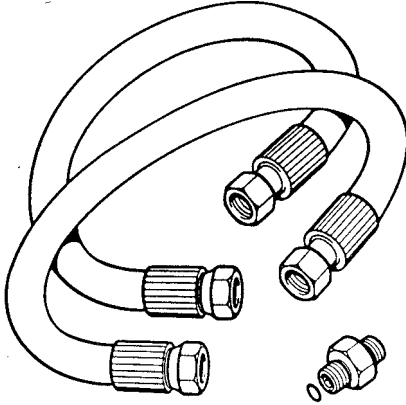

197210

892/00318 Hose And Adapter Kit
To enable flow and pressure test equipment to be connected to adapters fitted with 'O' ringface seals.

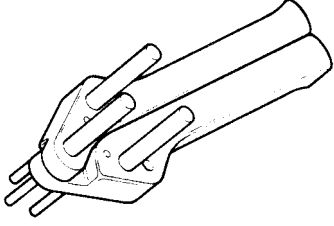

197220

892/00334 Gland Seal Fitting Tool



3 mm

331/64246 Tool Kit for Non-return Valve

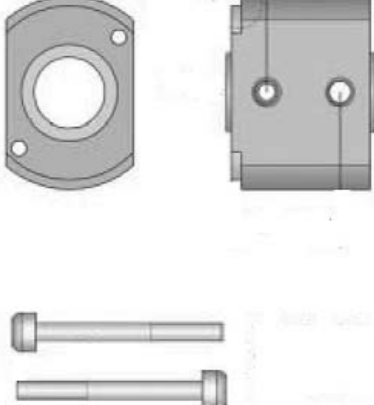

331/64265 Retaining Bush for Valve Spool

Service Tools

Section F - Transmission

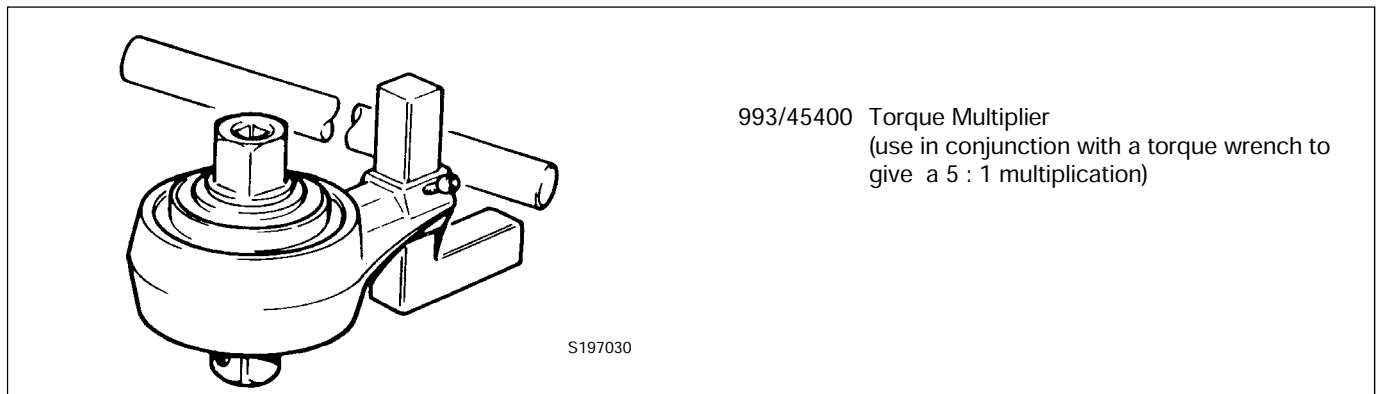
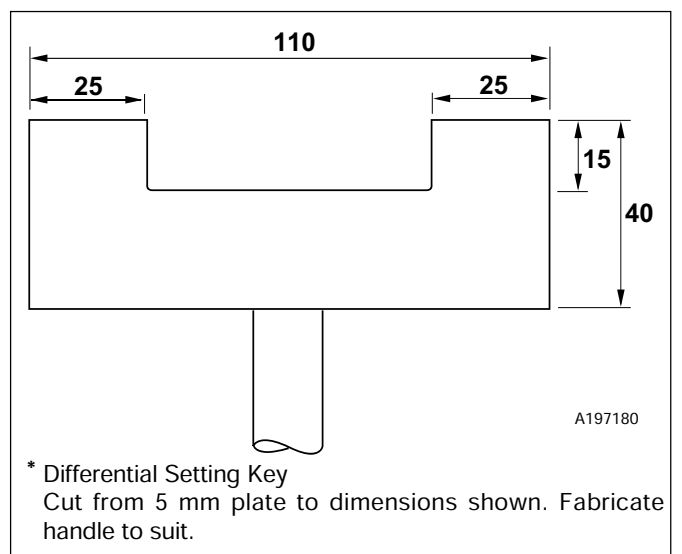
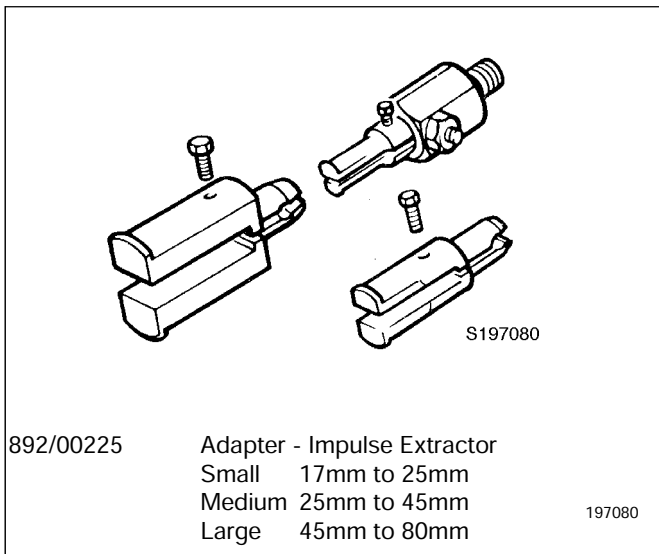
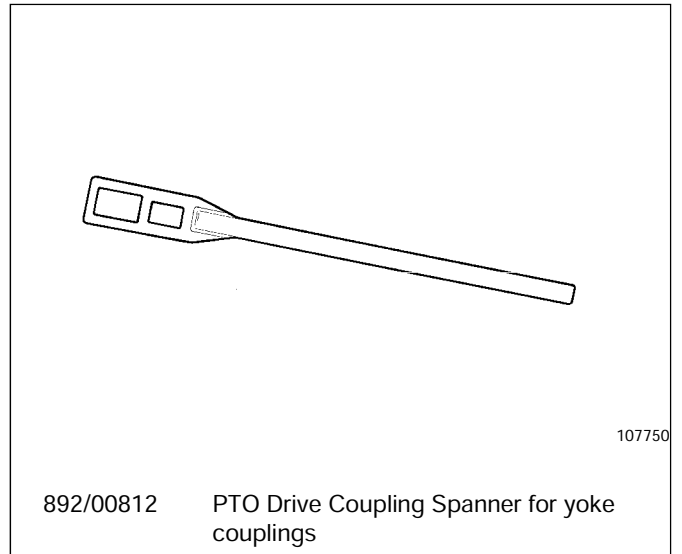
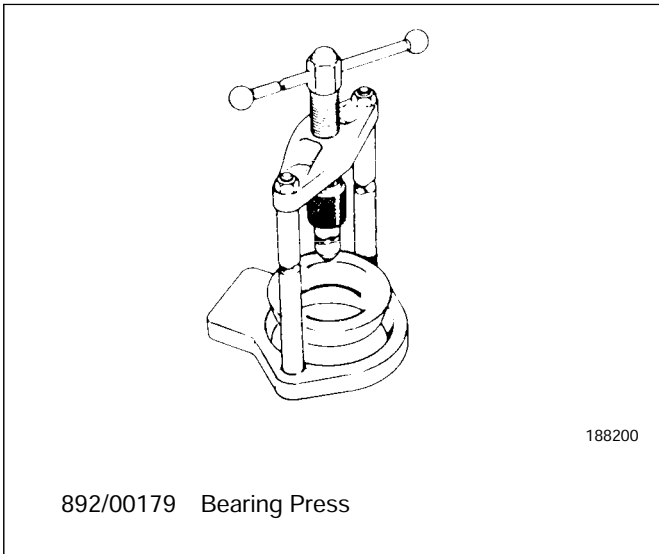

Service Tools (continued)

Section F - Transmission (continued)

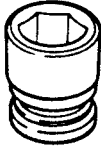

Heavy Duty Sockets 197250

892/00817	17 mm A/F x 3/4in. square drive
892/00818	22 mm A/F x 3/4in. square drive
892/00819	15 mm A/F x 1/2in. square drive
892/00333	19 mm A/F x 3/4in. square drive

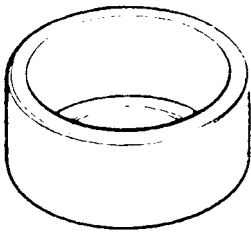

S190770

892/00174 Measuring Cup - Pinion Head Bearing

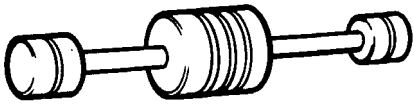

892/00224 Impulse Extractor Set
for Hub Bearing Seals

892/01053 Adapter for impulse extractor
(PTO intermediate shaft, wet clutch
transmission) S197070

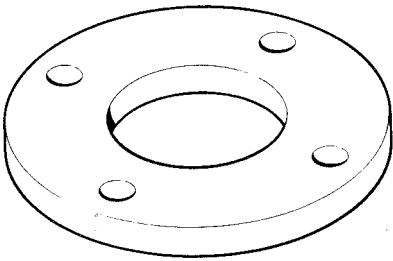

S197240

892/00312 Dummy End Plate for Range Gearbox

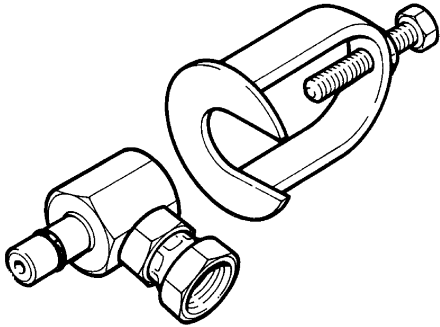

S196750

993/59300 2/4 WD Pressure Test Adaptor & Clamp

Service Tools (continued)

Section F - Transmission (continued)

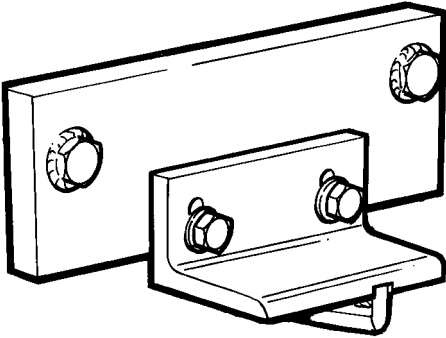

S226300 892/00892 Speed Gearbox Locking Tool

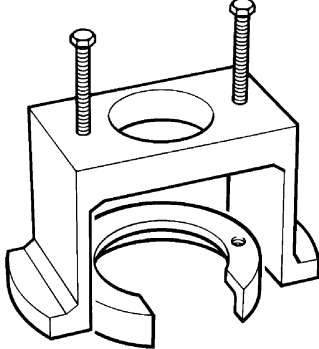

S267310 892/00916 Spring Compressor for Splitter and PTO Clutches

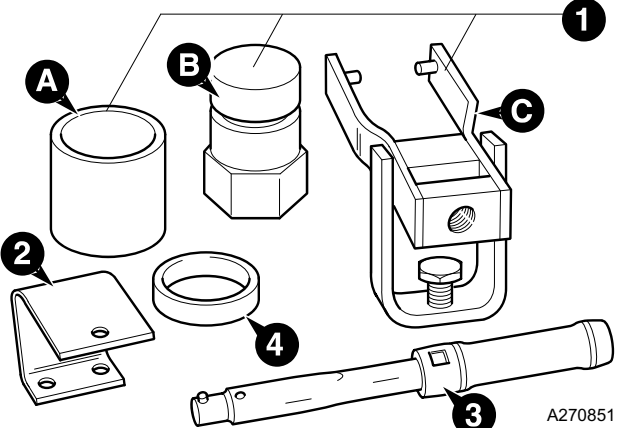

A270851

Solid Spacer Setting Tools

- 1 892/00918 Setting Tool Kit. Contains the following:
 - A Sleeve for M24 Pinion
 - B Adapter for M30 Pinion
 - C Fork (suitable for all axles)
- The following setting tools must be purchased separately:
- 892/00945 A Sleeve for M30 Pinion
 - 997/11100 B Adapter for M24 Pinion
 - 2 997/11000 Drive Head Setting Bracket
 - 3 993/70111 Break-back Torque Wrench
 - 4 - Solid spacer (see parts CD or microfiche for part numbers)

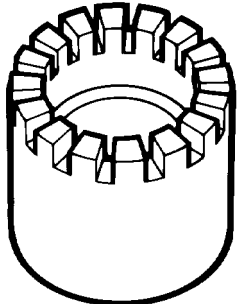

S234120 892/00864 PD 90 Axle Locknut Spanner

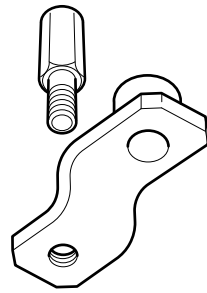

A361730 892/01052 (x2) Locking Plate for locking wet clutch drum to housing

Service Tools (continued)

Section F - Transmission (continued)

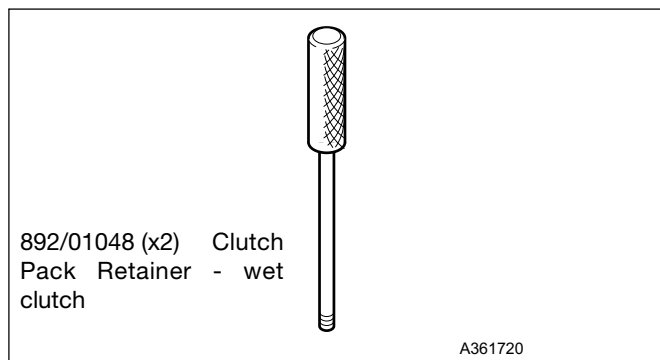
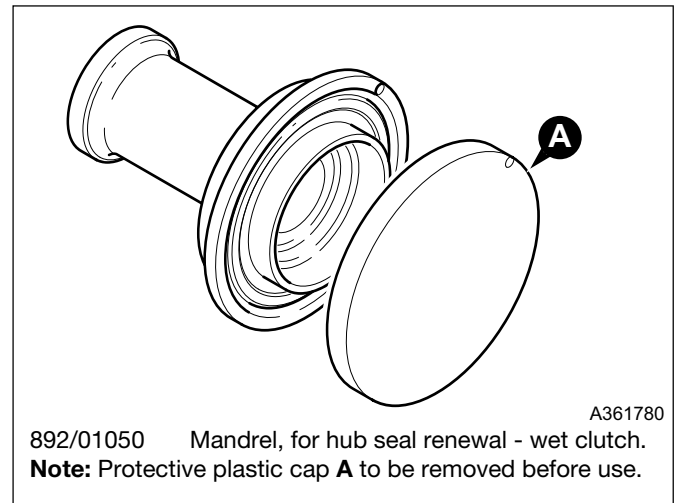
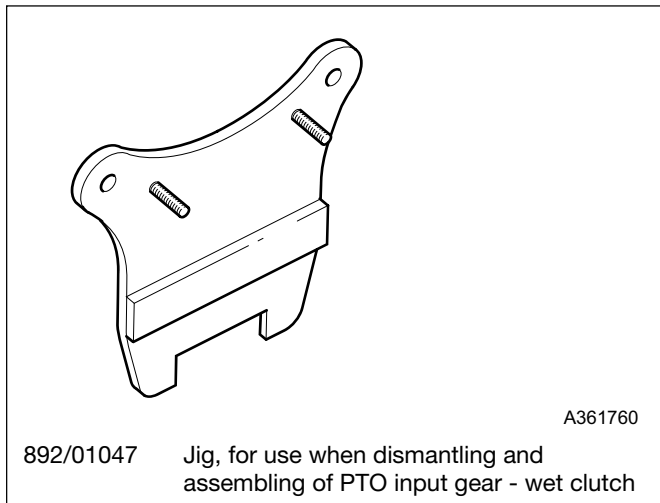
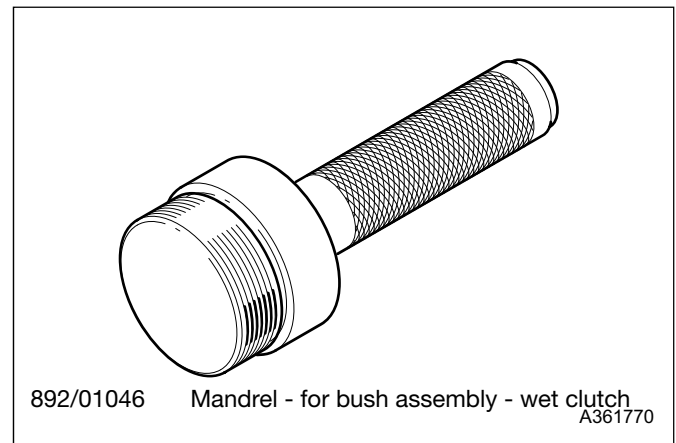
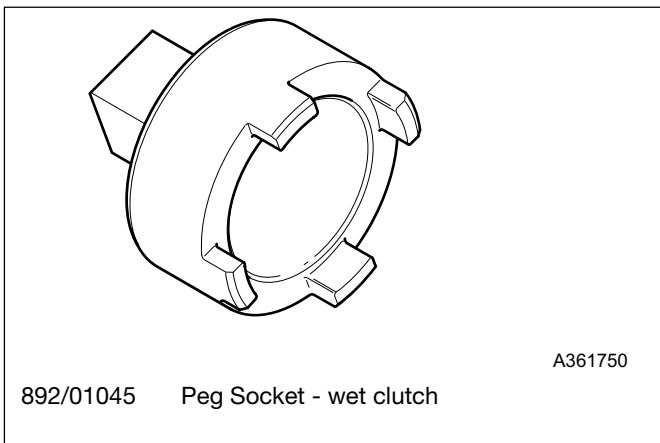
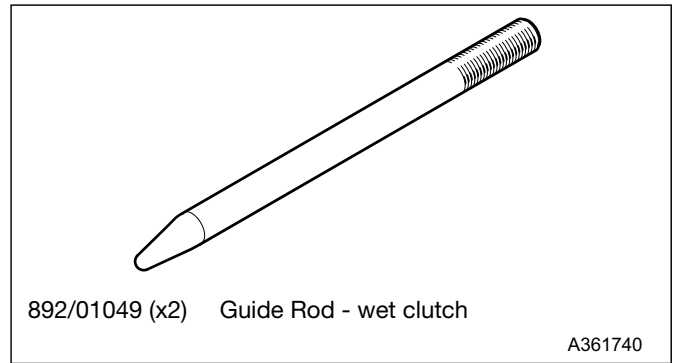
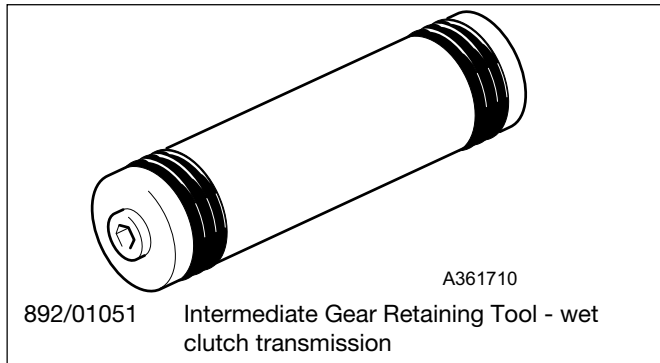

Service Tools (continued)

Item	Description	Part No.	Qty
A	Hub Service Kit	892/01092	1
comprises:			
1	Puller Beam	998/10623	1
2	Inner Bearing Plate	998/10607	1
3	Bolt M16x220	1315/3731Z	2
4	Nut M16	1370/0601Z	2
5	Reaction Tube	998/10614	1
6	Modified Wheel Stud	998/10624	2
7	Wheel Bearing Carrier Puller	998/10615	2
8	Nut M20	1370/0701Z	4
9	Washer M20	1420/0012Z	2
10	Puller Rod	998/10610	2
11	Nut M12	1370/0401Z	2
12	Washer M12	1420/0009Z	2
13	Bearing Centre Puller	998/10608	1
14	Bolt M10x60	1315/3414Z	1
15	Nut M10	1370/0301Z	1
16	Bearing Fitting Tube	998/10606	1
17	Puller Handle Nut	998/10616	1
18	Bolt M20x300	1315/3835Z	2
19	Washer	445/12303	2
20	Bearing	917/02800	1
21	Dolly	892/00891	1

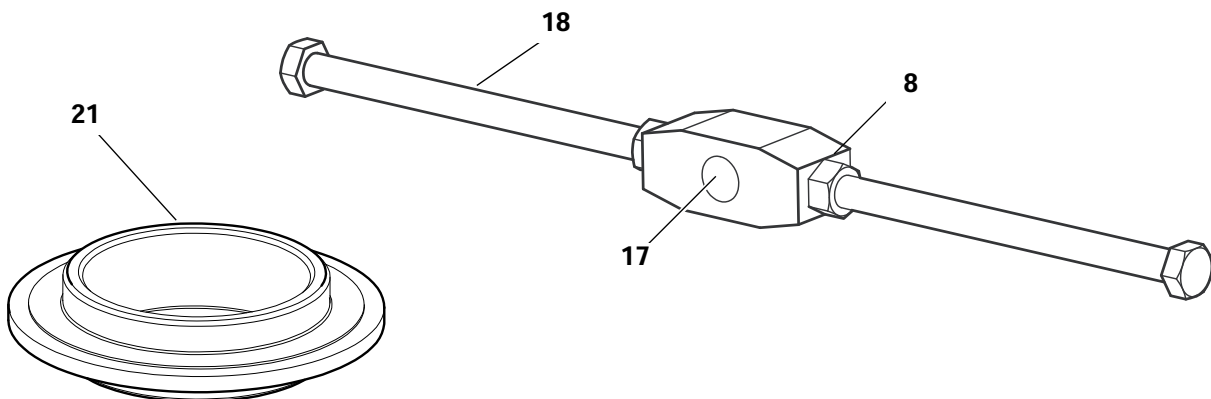
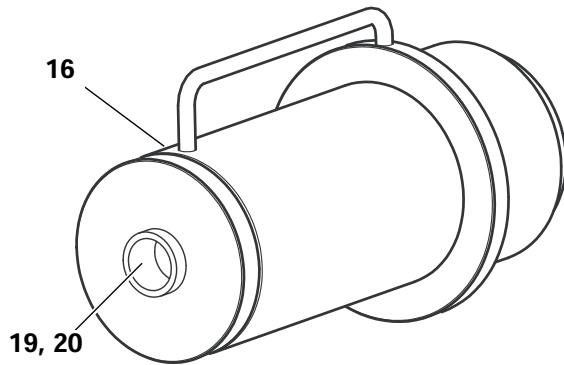
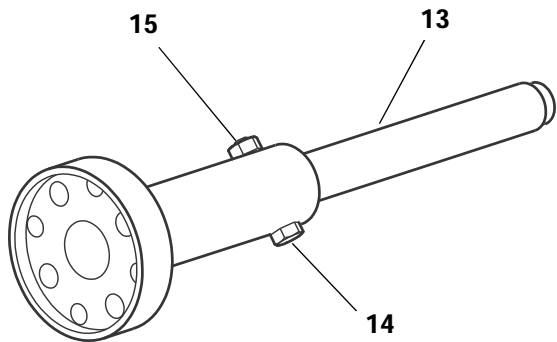
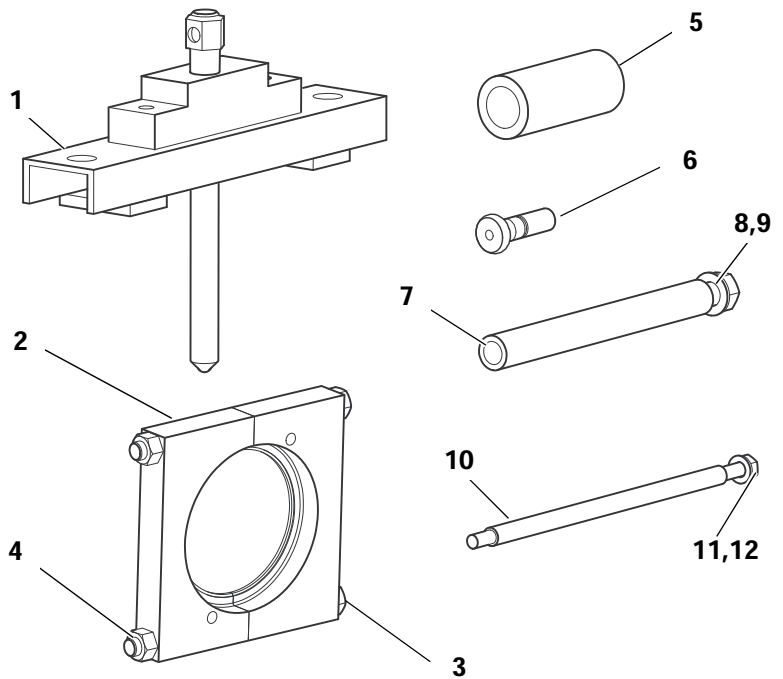

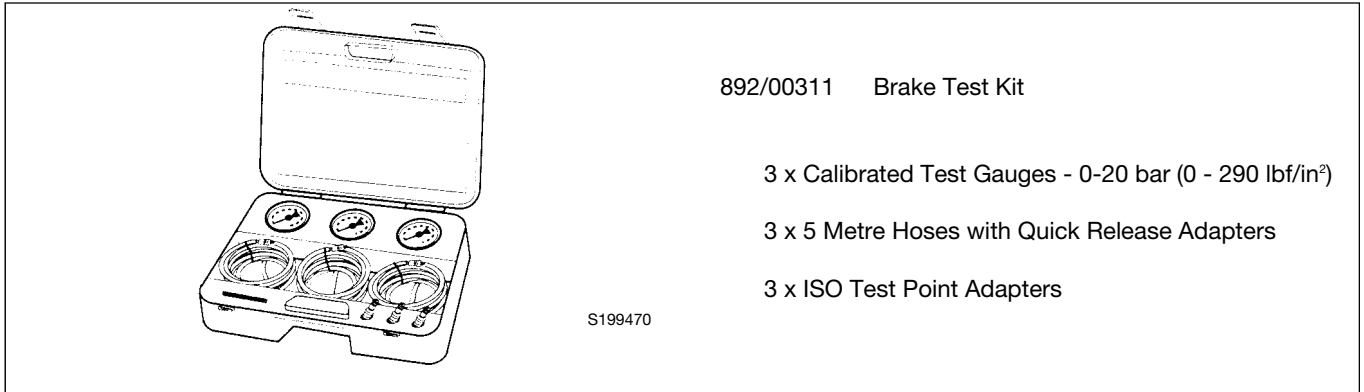
Service Tools (continued)**Section G - Brakes**

892/00311 Brake Test Kit

3 x Calibrated Test Gauges - 0-20 bar (0 - 290 lbf/in²)

3 x 5 Metre Hoses with Quick Release Adapters

3 x ISO Test Point Adapters

S199470

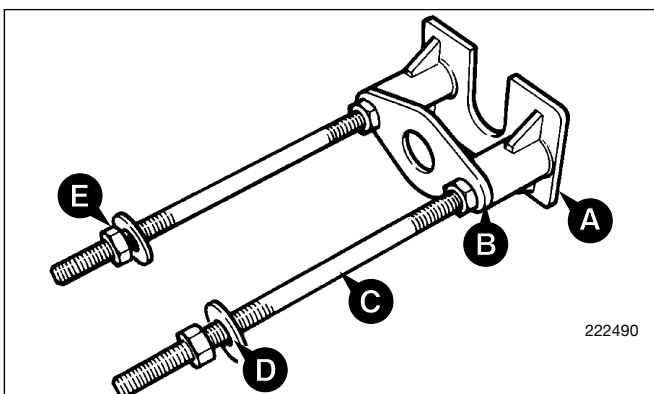
Section H - Steering

222490

Puller adapter assembly for removal of drop arm from steering box (3000 Series machines). Comprises:

A	892/00871	Frame	1 off
B	892/00874	Brace	1 off
C	892/00875	Bar M24	2 off
D	892/00876	Block	2 off
E	1370/0901Z	Nut M24	2 off

Use in conjunction with a 20 tonne hydraulic ram as obtainable from Sykes Pickavant to suit puller bars at 185 mm centres.

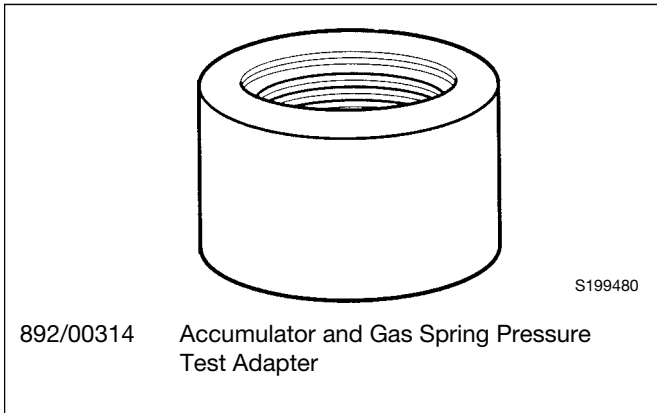
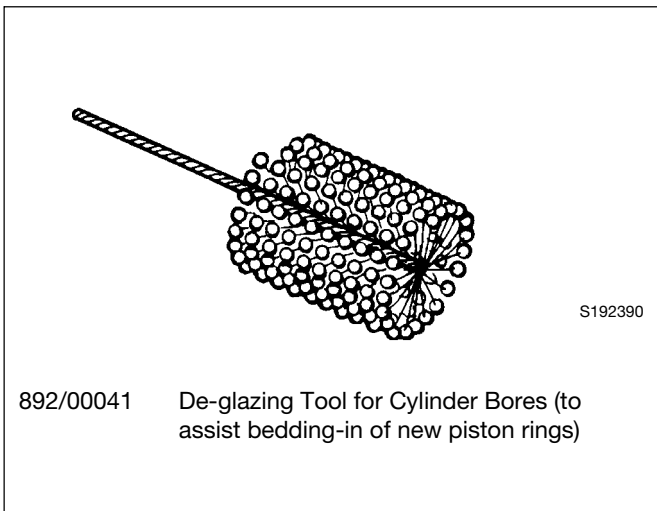
Service Tools (continued)**Section S - Suspension****Section T - Engine**

Note: For other engine tools refer to the relevant Engine Service Manual.

General

Do not tow a machine unless there is no alternative. Remember that more damage might be caused to the machine by towing it. If at all possible repair the machine where it stands.

* **Note:** It is not possible to tow-start or push-start the Fastrac due to the design of the transmission.

Make sure you will be obeying all pertinent laws and regulations before towing the machine on public roads.

⚠ DANGER

If the engine is not running, there will not be enough air to apply the service brakes or release the parking brake. Carefully follow the precautions in this section before moving the machine or there may be a serious accident.

13-2-2-6/1

⚠ CAUTION

Towing a machine too far or too fast can damage the transmission. Do not tow the machine further than one mile. Use a trailer for greater distances. When towing do not travel faster than 25 km/h (15 mph).

Use a rigid drawbar. If you must use towing chains, then use two towing vehicles. One towing vehicle should be coupled to the front of the disabled machine. The other towing vehicle should be coupled to the rear of the disabled machine, to provide braking power.

The towing vehicle(s) must have enough pulling and braking power to move and stop the machine.

2-2-7-3

Preparation for Towing

1 Connect the towing vehicle.

- a Apply the parking brakes on the towing vehicle and securely chock the wheels on the Fastrac.

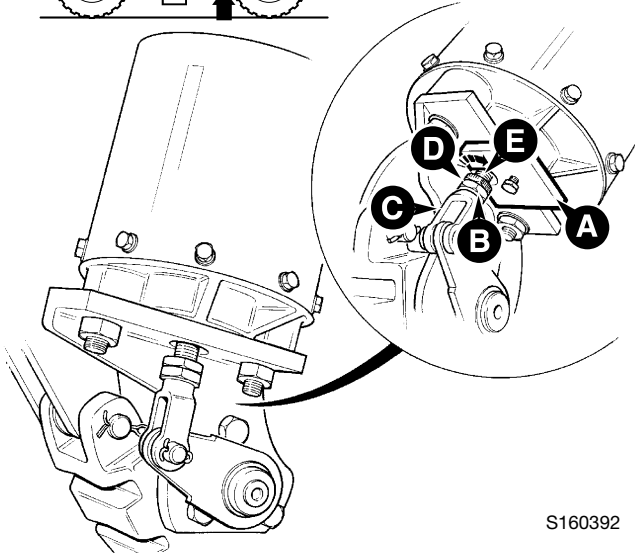
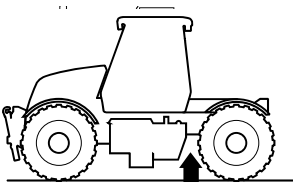

S160392

- b Fit the drawbar between towing vehicle and Fastrac.

2 Prepare the machine.

- a Make sure that the range and speed gearboxes are both in neutral.
- b If the gearbox has failed, disconnect both propshafts (see Section F).
- c If an axle has failed, remove the sun gears (see Section F).

3 Release the Fastrac parking brake.

If there is not enough air pressure to release the brake, start the engine to charge up the air system. If the engine cannot be run but the brake air system is serviceable, charge the system to 8 bar (120 lbf/in²) through Schrader valve **X** (machines with ABS) or **Y** (machines without ABS). **This job must be done by a qualified mechanic, using the correct equipment.**

⚠ DANGER

Ensure that the chocks and towing vehicle will prevent the Fastrac from moving as it is necessary to work under the machine to remove the propshafts or release the parking brake. When the propshafts have been disconnected the parking brake cannot prevent the machine from moving. When the parking brake has been manually released as described below, it will be impossible to apply the brake until plate **A** has been removed and the propshafts connected. Anyone working underneath, or near the machine, could be killed or seriously injured if the machine moved.

13-2-2-11/1

Alternatively, position plate **A** (if provided with the machine) as shown. Keeping nut **B** tight against clevis **C**, turn nut **D** against the plate so that rod **E** is drawn out of the actuator body and the parking brake is released.

Note: If the parking brake cannot be released, remove both propshafts (see Section F).

The machine is now ready for towing. If you will be steering the Fastrac, make sure you understand what the towing driver will be doing. Obey his instructions and all relevant regulations. Remember that the steering will be much heavier if the engine is not running.

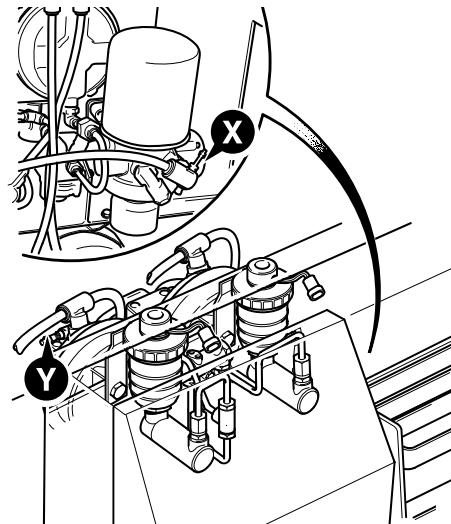

418150

Transporting the Machine

The safe transit of the load is the responsibility of the transport contractor and driver. Any machine, attachments or parts that may move during transit must be adequately secured.

5-2-5-9

Note: Before transporting the machine make sure you will be obeying the rules and laws of all the areas that the machine will be carried through.

Make sure that the transporting vehicle is suitable. See **Static Dimensions** (SPECIFICATIONS section in the machine handbook) for the dimensions of the machine.

WARNING

Before moving the machine onto the trailer, make sure that the trailer and ramp are free from oil, grease and ice. Remove oil, grease and ice from the machine tyres. Make sure the machine will not foul on the ramp angle. See Static Dimensions in SPECIFICATIONS section for the minimum ground clearance of your machine.

2-2-7-5/1

- 1 Place blocks at the front and rear of the trailer wheels.
- 2 Move the machine on to the trailer as follows:
 - a Make sure the ramps are correctly in place and secure.
 - b Carefully drive the machine onto the trailer.
 - c Set the drive to neutral and engage the parking brake.
 - d Switch off the engine.
 - e Ensure that the overall height of the load is within regulations.
 - f Secure the cab.

- 3 Anchor the machine to the trailer with chains or suitable webbing straps. The preferred fixing is to use webbing straps individually fixing all four wheels to the deck of the trailer as at **A**. If chains are used they should be connected to a suitable part of the drawbar at the rear of the machine. At the front, use the tie down points **B**. Avoid chaining any part of the machine where the chains may damage critical componentry. For example, chaining around either axle provides the possibility of damaging the steel brake pipes running along their length.
- 4 Measure the maximum height of the machine from the ground. Try to make sure the truck driver knows the clearance height before he drives away.

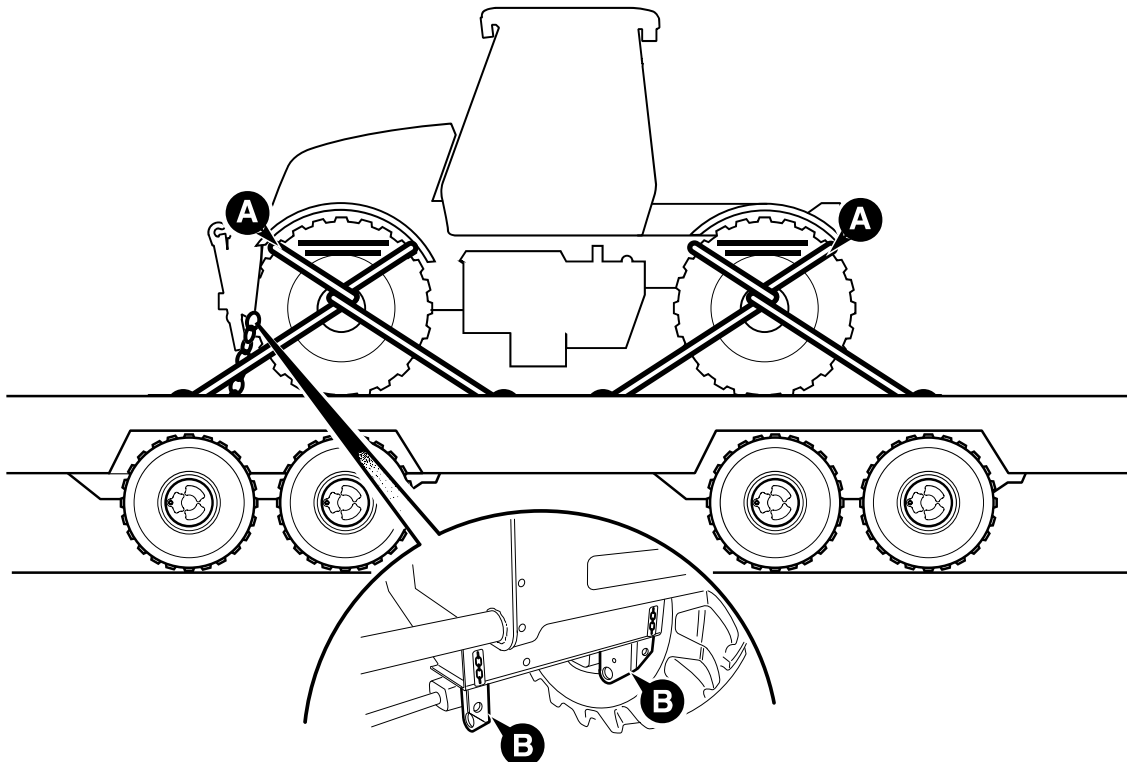

418300

Contents

Page No.

Safety Notices	1 - 1
General Safety	2 - 1
Operating Safety	3 - 1
Maintenance Safety	4 - 1

Sample of manual. Download All 830 pages at:

<https://www.arepairmanual.com/downloads/jcb-31703190320032203230-fastrac-service-repair-manual/>