



Section 3

Maintenance

[Section 1 - General Information](#)

[Section 2 - Care and Safety](#)

[Section 3 - Maintenance](#)

[Section A - Attachments](#)

[Section B - Body and Framework](#)

[Section C - Electrics](#)

[Section D - Controls](#)

[Section E - Hydraulics](#)

[Section F - Gearboxes](#)

[Section J - Track and Running Gear](#)

[Section K - Engine](#)

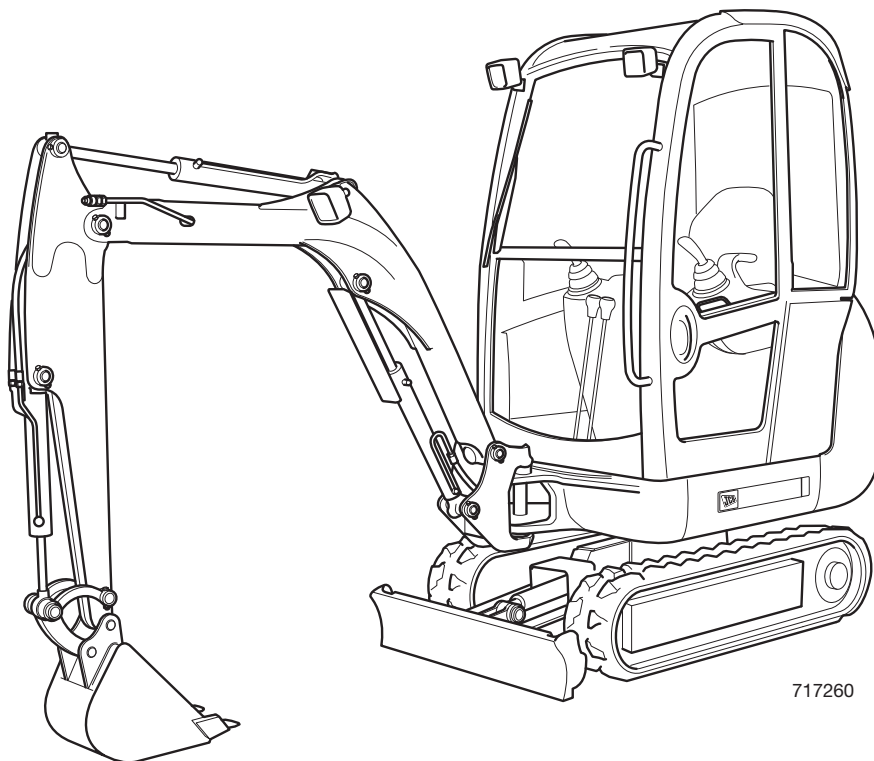

717260

Publication No.
9803/9350-3



Sample manual. Download All pages at.

<https://www.arepairmanual.com/downloads/jcb-801480168018-mini-excavator-service-repair-manual/>

World Class
Customer Support



Section 3 - Maintenance

Contents	Page No.
Routine Maintenance	
Service Requirements	3-1
Introduction	3-1
Owner/Operator Support	3-1
Service/Maintenance Agreements	3-1
Obtaining Replacement Parts	3-1
Health and Safety	3-2
Lubricants	3-2
Battery	3-4
First Aid - Electrolyte	3-4
Service Schedules	3-6
Introduction	3-6
How to Use the Service Schedules	3-6
Pre Start Cold Checks, Service Points and Fluid Levels	3-7
Functional Test and Final Inspection	3-9
Fluids, Lubricants and Capacities	3-10
Coolant Mixtures	3-10
Fuels	3-12
Cleaning the Machine	3-15
Introduction	3-15
Cleaning the Tracks	3-15
Checking for Damage	3-17
Seat Belt	3-18
Checking the Seat Belt Condition and Security	3-18
Checking the Cab/Canopy Frame	3-19
Greasing	3-20
Introduction	3-20
Pivot Pins	3-21
Every 50 Hours	3-22
Every 1000 Hours	3-23
Electrical System	3-24
Battery	3-24
Fuses	3-26
Bulbs	3-26
Engine	3-27
Checking the Oil Level	3-27
Changing the Oil and Filter	3-28
Changing the Air Filter Element	3-29
Checking the Coolant Level	3-30
Changing the Coolant	3-31
Adjusting the Fan Belt	3-32
Fuel System	3-33
Filling the Tank	3-33
Draining the Fuel Filter/Sedimenter (Tier 2 Machines)	3-34
Replacing the Fuel Filter Element (Tier 2 Machines)	3-35
Bleeding the System (Tier 2 Machines)	3-36
Draining the Fuel Filter/Sedimenter (Tier 3 Machines)	3-37
Replacing the Fuel Filter Element (Tier 3 Machines)	3-38
Replacing the Fuel Pre Filter Element (Tier 3 Machines)	3-39
Bleeding the System (Tier 3 Machines)	3-40
Hydraulic System	3-41
Checking and Adjusting the Fluid Level	3-41
Replacing the Hydraulic Filter	3-42
Checking the Ram Piston Rods	3-42



Contents	Page No.
Tracks and Running Gear	3-43
Checking the Track Gearbox Oil Level	3-43
Changing the Track Gearbox Oil	3-43
Checking the Track Tension	3-44

Routine Maintenance

Service Requirements

Introduction

Your machine has been designed and built to give maximum performance, economy and ease of use under a wide variety of operating conditions. Prior to delivery, your machine was inspected both at the Factory and by your Distributor to ensure that it reaches you in optimum condition. To maintain this condition and ensure trouble free operation it is important that the routine services, as specified in this Manual, are carried out by an approved JCB Distributor at the recommended intervals.

This section of the Manual gives full details of the service requirements necessary to maintain your JCB machine at peak efficiency.

It can be seen from the Service Schedules on the following pages that many essential service checks should only be carried out by a JCB trained specialist. Only JCB Distributor Service Engineers have been trained by JCB to carry out such specialist tasks, and only JCB Distributor Service Engineers are equipped with the necessary special tools and test equipment to perform such tasks, thoroughly, safely, accurately and efficiently.

JCB regularly updates its Distributors advising them of any product developments, changes in specifications and procedures. Therefore only a JCB Distributor is fully able to maintain and service your machine.

A Service Record Sheet or Book is provided which will enable you to plan your service requirements and keep a service history record. It should be dated, signed and stamped by your Distributor each time your machine is serviced.

Remember, if your machine has been correctly maintained, not only will it give you improved reliability but its resale value will be greatly enhanced.

Owner/Operator Support

JCB together with your Distributor wants you to be completely satisfied with your new JCB machine. If you do encounter a problem however, you should contact your Distributor's Service Department who are there to help you!

You will have been given the names of the relevant service contacts at your Distributor when the machine was installed.

To get the most from your Distributor please help them to satisfy you by:

- 1 Giving your name, address and telephone number.
- 2 Quoting your machine model and serial number.
- 3 Date of purchase and hours of work.
- 4 Nature of the problem.

Remember, only your JCB Distributor has access to the vast resources available at JCB to help support you. In addition, your Distributor is able to offer a variety of programmes covering Warranty, Fixed Price Servicing, Safety Inspections, including weight tests, covering both legal and insurance requirements.

Service/Maintenance Agreements

To help plan and spread the costs of maintaining your machine, we strongly recommend you take advantage of the many Service and Maintenance Agreements your Distributor can offer. These can be tailor made to meet your operating conditions, work schedule etc.

Please consult your JCB Distributor for details.

Obtaining Replacement Parts

We recommend you fit only JCB Genuine Parts. A Parts Book will help you identify parts and order them from your JCB distributor.

Your dealer will need to know the exact model, build and serial number of your machine. See **Identifying Your Machine** in INTRODUCTION section.

The data plate also shows the serial numbers of the engine, transmission and axle(s), where applicable. But remember if any of these units have been changed, the serial number on the data plate may be wrong. Check on the unit itself.

Health and Safety

T3-001_3

Lubricants

Introduction

It is most important that you read and understand this information and the publications referred to. Make sure all your colleagues who are concerned with lubricants read it too.

Hygiene

JCB lubricants are not a health risk when used properly for their intended purposes.

However, excessive or prolonged skin contact can remove the natural fats from your skin, causing dryness and irritation.

Low viscosity oils are more likely to do this, so take special care when handling used oils, which might be diluted with fuel contamination.

Whenever you are handling oil products you should maintain good standards of care and personal and plant hygiene. For details of these precautions we advise you to read the relevant publications issued by your local health authority, plus the following.

Storage

Always keep lubricants out of the reach of children.

Never store lubricants in open or unlabelled containers.

Waste Disposal

CAUTION

It is illegal to pollute drains, sewers or the ground. Clean up all spilt fluids and/or lubricants.

Used fluids and/or lubricants, filters and contaminated materials must be disposed of in accordance with local regulations. Use authorised waste disposal sites.

INT-3-2-14

All waste products should be disposed of in accordance with all the relevant regulations.

The collection and disposal of used oil should be in accordance with any local regulations. Never pour used engine oil into sewers, drains or on the ground.

Handling

New Oil

There are no special precautions needed for the handling or use of new oil, beside the normal care and hygiene practices.

Used Oil

Used engine crankcase lubricants contain harmful contaminants.

Here are precautions to protect your health when handling used engine oil:

- 1 Avoid prolonged, excessive or repeated skin contact with used oil.
- 2 Apply a barrier cream to the skin before handling used oil. Note the following when removing engine oil from skin:
 - a Wash your skin thoroughly with soap and water.
 - b Using a nail brush will help.
 - c Use special hand cleansers to help clean dirty hands.
 - d Never use petrol, diesel fuel, or paraffin for washing.
- 3 Avoid skin contact with oil soaked clothing.
- 4 Don't keep oily rags in pockets.
- 5 Wash dirty clothing before re-use.
- 6 Throw away oil-soaked shoes.



First Aid - Oil

Eyes

In the case of eye contact, flush with water for 15 minutes. If irritation persists, get medical attention.

Swallowing

If oil is swallowed do not induce vomiting. Get medical advice.

Skin

In the case of excessive skin contact, wash with soap and water.

Spillage

Absorb on sand or a locally approved brand of absorbent granules. Scrape up and remove to a chemical disposal area.

Fires

WARNING

Do not use water to put out an oil fire. This will only spread it because oil floats on water.

Extinguish oil and lubricant fires with carbon dioxide, dry chemical or foam. Fire fighters should use self contained breathing apparatus.

7-3-1-3_1

Battery

WARNING

Batteries give off an explosive gas. Do not smoke when handling or working on the battery. Keep the battery away from sparks and flames.

Battery electrolyte contains sulphuric acid. It can burn you if it touches your skin or eyes. Wear goggles. Handle the battery carefully to prevent spillage. Keep metallic items (watches, rings, zips etc) away from the battery terminals. Such items could short the terminals and burn you.

Set all switches in the cab to OFF before disconnecting and connecting the battery. When disconnecting the battery, take off the earth (-) lead first.

Re-charge the battery away from the machine, in a well ventilated area. Switch the charging circuit off before connecting or disconnecting the battery. When you have installed the battery in the machine, wait five minutes before connecting it up.

When reconnecting, fit the positive (+) lead first.

First Aid - Electrolyte

Do the following if electrolyte:

GETS INTO YOUR EYES

Immediately flush with water for 15 minutes, always get medical help.

IS SWALLOWED

Do not induce vomiting. Drink large quantities of water or milk. Then drink milk of magnesia, beaten egg or vegetable oil. Get medical help.

GETS ONTO YOUR SKIN

Flush with water, remove affected clothing. Cover burns with a sterile dressing then get medical help.

5-3-4-3_1

Warning Symbols

The following warning symbols may be found on the battery.

Symbol	Meaning
	Keep away from children.
	Shield eyes.
	No smoking, no naked flames, no sparks.
	Explosive Gas.
	Battery acid.
	Note operating instructions.

CAUTION

Do not disconnect the battery while the engine is running, otherwise the electrical circuits may be damaged.

INT-3-1-14

WARNING

Electrical Circuits

Understand the electrical circuit before connecting or disconnecting an electrical component. A wrong connection can cause injury and/or damage.

INT-3-1-4

DANGER

Electrolyte

Battery electrolyte is toxic and corrosive. Do not breathe the gases given off by the battery. Keep the electrolyte away from your clothes, skin, mouth and eyes. Wear safety glasses.

INT-3-2-1_3

CAUTION

Damaged or spent batteries and any residue from fires or spillage should be put in a closed acid proof receptacle and must be disposed of in accordance with local environmental waste regulations.

INT-3-1-12

WARNING

Battery Gases

Batteries give off explosive gases. Keep flames and sparks away from the battery. Do not smoke close to the battery. Make sure there is good ventilation in closed areas where batteries are being used or charged. Do not check the battery charge by shorting the terminals with metal; use a hydrometer or voltmeter.

INT-3-1-8

Service Schedules

Introduction

A poorly maintained machine is a hazard. Doing the regular maintenance and lubrication jobs listed in these schedules will help keep the machine in safe running order.

WARNING

Maintenance must be done only by suitably qualified and competent persons.

Before doing any maintenance make sure the machine is safe, it should be correctly parked on level ground.

To prevent anyone starting the engine, remove the starter key. Disconnect the battery when you are not using electrical power. If you do not take these precautions you could be killed or injured.

8-3-1-1

Apart from the daily jobs, the schedules are based on machine running hours. Keep a regular check on the hour meter reading. Do not use a machine which is due for a regular service. Rectify any defects found during regular maintenance before clearing the machine for use.

Calendar equivalents:

- Every 10 Hours = Daily
- Every 50 Hours = Weekly
- Every 500 Hours = Six Months
- Every 1000 Hours = 1 Year
- Every 2000 Hours = 2 Year

All jobs should be marked and logged → [Table 1.](#) ([□ 3-6](#))

Table 1.

Description	Symbol
No fault found job complete	✓
Fault found and corrected (Detail on report)	□
Follow up required (Detail on report)	x

How to Use the Service Schedules

T3-012_3

In the example shown, **A** shows all service requirements to be carried out every 10 hours and **B** shows the requirements to be carried out every 500 hours.

Important: Services should be carried out at either the hourly interval or calendar interval, whichever occurs first. Refer to **Calendar Equivalents**.

Operation	Interval						
	10	50	100 ⁽¹⁾	500	1000	2000	8000
ENGINE							
Coolant Quality and Level - Check	<input type="checkbox"/>	<input type="checkbox"/>	<input type="checkbox"/>	<input type="checkbox"/>	<input type="checkbox"/>		
Cooling System - Drain and Refill						<input type="checkbox"/>	<input type="checkbox"/>
Oil level - Check	<input type="checkbox"/>	<input type="checkbox"/>					
Oil and Filter ⁽²⁾⁽³⁾ - Change				<input type="checkbox"/>	<input type="checkbox"/>	<input type="checkbox"/>	<input type="checkbox"/>
Air Cleaner Dust Valve ⁽⁵⁾ - Change				<input type="checkbox"/>	<input type="checkbox"/>	<input type="checkbox"/>	<input type="checkbox"/>
Air Cleaner Outer Element ⁽⁵⁾ - Change					<input type="checkbox"/>	<input type="checkbox"/>	<input type="checkbox"/>
Air Cleaner Inner Element - Change						<input type="checkbox"/>	<input type="checkbox"/>
Pre-Cleaner (if fitted) - Check			<input type="checkbox"/>				
Water Separator - Check for contamination and Drain		<input type="checkbox"/>	<input type="checkbox"/>	<input type="checkbox"/>	<input type="checkbox"/>	<input type="checkbox"/>	<input type="checkbox"/>
Engine Fuel Filter - Change					<input type="checkbox"/>	<input type="checkbox"/>	<input type="checkbox"/>
Front End Accessory Drive (FEAD) Belt Condition - Check					<input type="checkbox"/>	<input type="checkbox"/>	<input type="checkbox"/>
Front End Accessory Drive (FEAD) Belt - Change							<input type="checkbox"/>
Engine Mounting Bolts for Tightness - Check				<input type="checkbox"/>	<input type="checkbox"/>	<input type="checkbox"/>	<input type="checkbox"/>
All Hoses - Condition - Check			<input type="checkbox"/>	<input type="checkbox"/>	<input type="checkbox"/>	<input type="checkbox"/>	<input type="checkbox"/>
Radiator ⁽⁶⁾ - Clean				<input type="checkbox"/>	<input type="checkbox"/>	<input type="checkbox"/>	<input type="checkbox"/>
Crankcase Ventilation Filter - Change					<input type="checkbox"/>	<input type="checkbox"/>	<input type="checkbox"/>

795390-1



Section 3 - Maintenance Routine Maintenance

Service Schedules

Pre Start Cold Checks, Service Points and Fluid Levels

	Operation	10	50	500	1000	2000
ENGINE						
Oil level	- Check	<input type="checkbox"/>	<input type="checkbox"/>	<input type="checkbox"/>	<input type="checkbox"/>	<input type="checkbox"/>
Oil and Filter	- Change			<input type="checkbox"/>	<input type="checkbox"/>	<input type="checkbox"/>
Air Cleaner Element (Dusty Conditions only)	- Change			<input type="checkbox"/>	<input type="checkbox"/>	<input type="checkbox"/>
Air Cleaner Outer Element	- Change				<input type="checkbox"/>	<input type="checkbox"/>
Air Cleaner Hose Security	- Check and Adjust		<input type="checkbox"/>	<input type="checkbox"/>	<input type="checkbox"/>	<input type="checkbox"/>
Air Filter Dust Valve	- Check and Clean			<input type="checkbox"/>	<input type="checkbox"/>	<input type="checkbox"/>
Fuel Injectors ⁽¹⁾	- Clean and Test					<input type="checkbox"/>
Coolant Quality/Level	- Check	<input type="checkbox"/>	<input type="checkbox"/>	<input type="checkbox"/>	<input type="checkbox"/>	<input type="checkbox"/>
Coolant	- Change					<input type="checkbox"/>
Fuel Lift Pump	- Clean			<input type="checkbox"/>	<input type="checkbox"/>	<input type="checkbox"/>
Fuel Sedimenter	- Drain and Clean		<input type="checkbox"/>	<input type="checkbox"/>	<input type="checkbox"/>	<input type="checkbox"/>
Fuel Filter/Sedimenter Element	- Change			<input type="checkbox"/>	<input type="checkbox"/>	<input type="checkbox"/>
Primary Fuel Filter	- Check			<input type="checkbox"/>	<input type="checkbox"/>	<input type="checkbox"/>
Fuel Pre Filter (Tier 3 Machines only)	- Check			<input type="checkbox"/>	<input type="checkbox"/>	<input type="checkbox"/>
Fan Belt Tension/Condition	- Check and Adjust		<input type="checkbox"/>	<input type="checkbox"/>	<input type="checkbox"/>	<input type="checkbox"/>
Valve Clearances ⁽¹⁾	- Check and Adjust				<input type="checkbox"/>	<input type="checkbox"/>
Cylinder Head Bolts for Tightness	- Check and Adjust			<input type="checkbox"/>	<input type="checkbox"/>	<input type="checkbox"/>
Engine Mounting Bolts for Tightness	- Check and Adjust			<input type="checkbox"/>	<input type="checkbox"/>	<input type="checkbox"/>
Exhaust System Security	- Check and Adjust			<input type="checkbox"/>	<input type="checkbox"/>	<input type="checkbox"/>
Radiator	- Clean and Check	<input type="checkbox"/>	<input type="checkbox"/>	<input type="checkbox"/>	<input type="checkbox"/>	<input type="checkbox"/>
TRANSMISSION						
Security of Mounting Bolts and Nuts						
- Track Wheel Motor to Undercarriage Bolts	- Check			<input type="checkbox"/>	<input type="checkbox"/>	<input type="checkbox"/>
- Drive Sprocket Bolts	- Check			<input type="checkbox"/>	<input type="checkbox"/>	<input type="checkbox"/>
- Slew Gearbox Bolts	- Check				<input type="checkbox"/>	<input type="checkbox"/>
Track Gearbox Oil	- Change			<input type="checkbox"/>	<input type="checkbox"/>	<input type="checkbox"/>
HYDRAULICS						
Oil Level	- Check	<input type="checkbox"/>	<input type="checkbox"/>	<input type="checkbox"/>	<input type="checkbox"/>	<input type="checkbox"/>
Oil	Change					<input type="checkbox"/>
Rams - Chrome Condition	- Check		<input type="checkbox"/>	<input type="checkbox"/>	<input type="checkbox"/>	<input type="checkbox"/>
Hoses and Pipework - Damage/Leaks	- Check		<input type="checkbox"/>	<input type="checkbox"/>	<input type="checkbox"/>	<input type="checkbox"/>
Return Filter Element	- Change			<input type="checkbox"/>	<input type="checkbox"/>	<input type="checkbox"/>
Suction Strainer	- Clean				<input type="checkbox"/>	<input type="checkbox"/>
Security of Mounting Bolts on Major Assemblies	- Check				<input type="checkbox"/>	<input type="checkbox"/>
ELECTRICS						



Section 3 - Maintenance Routine Maintenance

Service Schedules

	Operation	10	50	500	1000	2000
Battery Electrolyte Level (if applicable)	- Check			<input type="checkbox"/>	<input type="checkbox"/>	<input type="checkbox"/>
Starter Motor and Alternator Brush Gear	- Check					<input type="checkbox"/>
Wiring for Chaffing/Routing	- Check		<input type="checkbox"/>	<input type="checkbox"/>	<input type="checkbox"/>	<input type="checkbox"/>
Battery Terminals for Condition and Tightness	- Check		<input type="checkbox"/>	<input type="checkbox"/>	<input type="checkbox"/>	<input type="checkbox"/>
UNDERCARRIAGE						
Track Rollers Bolts	- Check			<input type="checkbox"/>	<input type="checkbox"/>	<input type="checkbox"/>
Track Rollers Oil and Seals	- Change				<input type="checkbox"/>	<input type="checkbox"/>
Idler Wheels Oil and Seals	- Change				<input type="checkbox"/>	<input type="checkbox"/>
Track Plate Condition and Bolt Torque	- Check		<input type="checkbox"/>	<input type="checkbox"/>	<input type="checkbox"/>	<input type="checkbox"/>
Track Tension	- Check		<input type="checkbox"/>	<input type="checkbox"/>	<input type="checkbox"/>	<input type="checkbox"/>
BODYWORK AND CAB						
Cab Mounting Bolts Security	- Check and Adjust				<input type="checkbox"/>	<input type="checkbox"/>
All Pivot Pins	- Grease	<input type="checkbox"/>	<input type="checkbox"/>	<input type="checkbox"/>	<input type="checkbox"/>	<input type="checkbox"/>
Kingpost - kingpin retaining plate bolts torque	- Check			<input type="checkbox"/>	<input type="checkbox"/>	<input type="checkbox"/>
Slew Ring Bearing	- Grease		<input type="checkbox"/>	<input type="checkbox"/>	<input type="checkbox"/>	<input type="checkbox"/>
Slew Ring Mounting Bolts	- Check				<input type="checkbox"/>	<input type="checkbox"/>
Slew Ring Pinion and Gear Teeth	- Grease				<input type="checkbox"/>	<input type="checkbox"/>
Door/Window Hinges	- Lubricate		<input type="checkbox"/>	<input type="checkbox"/>	<input type="checkbox"/>	<input type="checkbox"/>
Windscreen Washer Fluid Level	- Check	<input type="checkbox"/>	<input type="checkbox"/>	<input type="checkbox"/>	<input type="checkbox"/>	<input type="checkbox"/>
Machine Generally	- Check and Clean	<input type="checkbox"/>	<input type="checkbox"/>	<input type="checkbox"/>	<input type="checkbox"/>	<input type="checkbox"/>
ATTACHMENTS						
Quick Hitch	- Grease	<input type="checkbox"/>	<input type="checkbox"/>	<input type="checkbox"/>	<input type="checkbox"/>	<input type="checkbox"/>
OPTIONAL EQUIPMENT						
As Required	- Check	<input type="checkbox"/>	<input type="checkbox"/>	<input type="checkbox"/>	<input type="checkbox"/>	<input type="checkbox"/>

(1) Jobs which should only be done by a specialist.



Section 3 - Maintenance Routine Maintenance

Service Schedules

Functional Test and Final Inspection

	Operation	10	50	500	1000	2000
ENGINE						
Idle and Maximum Speed ⁽¹⁾	- Check and Adjust			<input type="checkbox"/>	<input type="checkbox"/>	<input type="checkbox"/>
Exhaust Smoke (excessive)	- Check	<input type="checkbox"/>	<input type="checkbox"/>	<input type="checkbox"/>	<input type="checkbox"/>	<input type="checkbox"/>
Fuel System - Leaks and Contamination	- Check	<input type="checkbox"/>	<input type="checkbox"/>	<input type="checkbox"/>	<input type="checkbox"/>	<input type="checkbox"/>
HYDRAULICS						
Operation All Services - Excavator, Dozer etc.	- Check	<input type="checkbox"/>	<input type="checkbox"/>	<input type="checkbox"/>	<input type="checkbox"/>	<input type="checkbox"/>
Hoses and Pipework - Damage/Leaks	- Check		<input type="checkbox"/>	<input type="checkbox"/>	<input type="checkbox"/>	<input type="checkbox"/>
Main Relief Valve Pressure ⁽¹⁾	- Check and Adjust			<input type="checkbox"/>	<input type="checkbox"/>	<input type="checkbox"/>
Auxiliary Relief Valve Pressure ⁽¹⁾	- Check and Adjust			<input type="checkbox"/>	<input type="checkbox"/>	<input type="checkbox"/>
Slew Cross Line Relief Valve Pressure ⁽¹⁾	- Check and Adjust			<input type="checkbox"/>	<input type="checkbox"/>	<input type="checkbox"/>
Servo Relief Valve Pressure ⁽¹⁾	- Check and Adjust			<input type="checkbox"/>	<input type="checkbox"/>	<input type="checkbox"/>
ELECTRICS						
All Electrical Equipment Operation, (e.g. warning lights, beacon, alarms, horn, wipers etc.)	- Check	<input type="checkbox"/>	<input type="checkbox"/>	<input type="checkbox"/>	<input type="checkbox"/>	<input type="checkbox"/>
Hourmeter Operation	- Check	<input type="checkbox"/>	<input type="checkbox"/>	<input type="checkbox"/>	<input type="checkbox"/>	<input type="checkbox"/>
UNDERCARRIAGE						
Track and Running Gear Operation	- Check	<input type="checkbox"/>	<input type="checkbox"/>	<input type="checkbox"/>	<input type="checkbox"/>	<input type="checkbox"/>
BODYWORK AND CAB						
Excavator Lever and Swing Pedal Locks	- Check			<input type="checkbox"/>	<input type="checkbox"/>	<input type="checkbox"/>

(1) Jobs which should only be done by a specialist.

Fluids, Lubricants and Capacities

Table 2.

Item	Capacity Litres (Gal)	Fluid / Lubricant	International Specification
Fuel Tank	23.5 (5.2)	Diesel Oil	
Engine (Oil)	4.0 (0.9)	JCB 10W/30 Multigrade above -15°C (above 5°F)	MIL-L-46152, API CC/SF
		5W/20 -15°C to -25°C (5°F to 13°F)	API CC/SE (recommended)
Engine Coolant		JCB High Performance Antifreeze and Inhibitor/Water → Coolant Mixtures (□ 3-11)	ASTM D3306-74
Canopy	4.5 (1.0)		
Cab	5.0 (1.1)		
Track Gearbox (each)	0.3 (0.07)	JCB SAE 30 Engine Oil (Not Multigrade)	API CD/SF, MIL-L-46152, MIL-L-2104D
Track Idler Wheels	0.025 (0.006)	JCB HD90 Gear oil	API-GL-5, MIL-L-2105D
Track Rollers (bottom)	0.025 (0.006)	JCB HD90 Gear Oil	API-GL-5, MIL-L-2105D
Hydraulic System	30 (6.6)	JCB Special Hydraulic Fluid Up to 30°C (86°F) JCB Hydraulic Fluid 46 Over 30°C (86°F)	
Slew Ring Bearings		JCB MPL Grease	Lithium based no 2 consistency
Slew Ring Gear Teeth		JCB Slew Pinion Grease	
All Other Grease		JCB MPL Grease	Lithium based no 2 consistency

WARNING

Slew Pinion Grease

JCB Slew Pinion Grease is harmful as it contains bitumen compounds 2811. Excessive contact may lead to dermatitis or skin cancer. Always use a barrier cream or wear gloves; wash contaminated skin thoroughly with soap and water. In the event of eye contact, immediately wash with plenty of water and seek medical advice.

8-1-1-7

Coolant Mixtures

T3-009_3

Check the strength of the coolant mixture at least once a year, preferably at the start of the cold period.

Replace the coolant mixture according to the intervals shown in the machine's Service Schedule.

WARNING

Antifreeze can be harmful. Obey the manufacturer's instructions when handling full strength or diluted antifreeze.

7-3-4-4_1

You must dilute full strength antifreeze with clean water before use. Use clean water of no more than a moderate hardness (pH value 8.5). If this cannot be obtained, use de-ionized water. For further information advice on water hardness, contact your local water authority.

The correct concentration of antifreeze protects the engine against frost damage in winter and provides year round protection against corrosion.

The protection provided by JCB High Performance Antifreeze and Inhibitor is shown below.

50% Concentration (Standard)

Protects against damage down to -40 °C (-39 °F)

60% Concentration (Extreme Conditions Only)

Protects against damage down to -56 °C (-68 °F)

Important: Do not exceed a 60% concentration, as the freezing protection provided reduces beyond this point.

If you use any other brand of antifreeze:

- Ensure that the antifreeze complies with International Specification ASTM D6210.
- Always read and understand the manufacturer's instructions.
- Ensure that a corrosion inhibitor is included. Serious damage to the cooling system can occur if corrosion inhibitors are not used.
- Ensure that the antifreeze is ethylene glycol based and does not use Organic Acid Technology (OAT).

Fuels



Acceptable and Unacceptable Fuels

T3-048

Important: No warranty liability whatsoever will be accepted for failure of fuel injection equipment where the failure is attributed to the quality and grade of the fuel used.

Consult your fuel supplier or JCB distributor about the suitability of any fuel you are unsure of.

GEN-9-2

Table 3.

Fuel Specification	Applicable Engines	Service Requirements
EN590 Diesel fuel types - Auto/C0/C1/C2/C3/C4	All	Obey the usual routine maintenance schedules and procedures.
BS2869 Class A2		
ASTM D975-076 2-D, US DF1, US DF2, US DFA		
JIS K2204 Grades 1, 2, 3 and Special Grade 3		
ASTM D975-076 1-D	All <i>Important: Engines operated with these fuels may have a reduced service life.</i>	Obey the usual routine maintenance schedules and procedures. Fuel additives are recommended for use with low sulphur fuels ⁽¹⁾ . ⇒ Additives (□ 3-13) .
MIL T38219 JP7		
NATO F63		
French EN590 (RME5) with 5% maximum		
AVTURFSII, NATO F34, JP8, MIL T83133, DERD 2463, DEF STAN 91-87	All <i>Important: Engines operated with these fuels may have a reduced service life.</i>	Obey the usual routine maintenance schedules and procedures. Fuel additives must be used ⁽¹⁾ . ⇒ Additives (□ 3-13) .
AVCAT FSII, NATO F44, JP5, MIL T5624, DERD 2452, AVTOR		
NATO F35, JET A1, DEF STAN 91-91, DERD 2494, XF63		
AVCAT, NATO F43 (obsolete), JP5 without additives		
JET A (ASTM D1655)		
ASTM D3699 Kerosene		
B5 Biodiesel - RME content blended with mineral derived diesel (5% maximum) - ASTM D6751, DIN 51606, ISO 14214	Tier 3 only ⁽²⁾ .	You must obey special routine maintenance schedules and procedures. ⇒ Warranty (□ 3-13) .
AVTAG (obsolete)	These fuels are not acceptable with or without additives. Engines must not be operated with these fuels.	
AVTAG FSII (obsolete), NATO F40, JP4, DERD 2454		
JET B (ASTM D1655)		
BS MA100		
JIS K2203 No.2		
Unmodified vegetable oils		

(1) Use a fuel additive (where instructed) to make sure that the fuel meets the minimum lubricity requirement.

(2) Refer to Typical Engine Identification Number.

Additives

The additives listed below are advertised as being suitable for bringing the lubricity levels of kerosene/low sulphur fuels up to those of diesel fuels. They must be used as specified by your fuel supplier who will understand the concentration level necessary.

Important: *The lubricity wear scar diameter must not be more than 460 microns, as tested on a high frequency reciprocating rig at 60°C (140°F). Refer to ISO 12156-1.*

- Elf 2S 1750. Dosage 1000-1500 ppm (0.1 - 0.15%), specifically for Indian Superior Kerosene (SKO) but may be applicable to other fuels.
- Lubrizol 539N. Dosage (on Swedish low sulphur fuel) 250 ppm.
- Paradyne 7505 (from Infineum). Dosage 500 ppm (0.05%).

Note: *These products are given as examples only. The information is derived from the manufacturers data. The products are not recommended or endorsed by JCB.*

Service Requirements for use of B5 Biodiesel

- The engine oil must be a grade CH4 as minimum specification.
- Do not leave unused B5 biodiesel in the fuel tank for extended periods (top up each day).
- Make sure that 1 in 5 fuel tank fills use standard diesel to EN590 specification, this will help to prevent 'gumming'.
- Make sure regular oil sampling is completed (look for excessive unburnt fuel content, water or wear particles).
- Change the engine oil and filter more frequently (as a minimum half the recommended intervals), or as indicated by oil sampling.
- Change the fuel filters more frequently (as a minimum half the recommended intervals), or if there are engine performance related issues.
- Make sure the fuel is stored correctly, care must be taken to make sure no water enters the machine fuel

tank (or the storage tank). Water will encourage micro-bacterial growth.

- Make sure that the fuel pre-filter is drained daily (not every week as currently advised).
- Only Tier 3 engines (factory filled with CH4 oil) - this is not approved with other manufacturers.
- Use heater kits in low ambient temperature territories.
- The biodiesel must meet the following standards: ASTM D6751, DIN 51606, ISO 14214

Note: *If necessary use a test kit to confirm the fuel specification. Testing kits are available (not from JCB currently), use the internet as a source for the kits.*

Note: *If performance related issues are to be reported to JCB Service, and the engine has been run on biodiesel, then the fuel system must be filled with standard diesel (at least 2 x tank fills) to EN590 specification and relevant stall speeds recorded prior to making the report.*

Warranty

JCB have shown a commitment to support the environment by approving the use of biodiesel blended fuels.

Using a B5 blend of biodiesel requires caution and additional servicing of the engine is required. → [Service Requirements for use of B5 Biodiesel \(□ 3-13\)](#).

Failure to follow the additional recommended service requirements may lead to a warranty claim being declined.

Failures resulting by the incorrect use of biodiesels or other fuel additives are not defects of the engine workmanship and therefore will not be supported by JCB Warranty.

Sulphur Content

T3-032

High sulphur content can cause engine wear. (High sulphur fuel is not normally found in North America, Europe or Australia.) If you have to use high sulphur fuel you must change the engine oil more frequently. ⇒ [Table 4. Sulphur Content \(□ 3-14\)](#).

Low sulphur fuels must have the appropriate fuel lubricity additives, these lubricity improvers must not create residual deposits that block the fuel system, e.g. injectors, filters etc. Contact your fuel Supplier.

CAUTION

A combination of water and sulphur will have a corrosive chemical effect on fuel injection equipment. It is essential that water is eradicated from the fuel system when high sulphur fuels are used.

ENG-3-2

Table 4. Sulphur Content

Percentage of sulphur in the fuel (%)	Oil Change Interval
Less than 0.5	Normal
0.5 to 1.0	0.75 of normal
More than 1.0	0.50 of normal

Effects of Fuel Contaminates

T3-033

The effect of dirt, water and other contaminants in diesel can be disastrous for injection equipment:

- **Dirt** - A severely damaging contaminant. Finely machined and mated surfaces such as delivery valves and distributor rotors are susceptible to the abrasive nature of dirt particles - increased wear will almost inevitably lead to greater leakage, uneven running and poor fuel delivery.
- **Water** - Water can enter fuel through poor storage or careless handling, and will almost inevitably condense in fuel tanks. The smallest amounts of water can result in effects that are just as disastrous to the fuel injection pump as dirt, causing rapid wear, corrosion and in severe cases, even seizure. It is vitally important that water is prevented from reaching the fuel injection equipment. The filter/water trap must be drained regularly.
- **Wax** - Wax is precipitated from diesel when the ambient temperature falls below that of the fuel's cloud point, causing a restriction in fuel flow resulting in rough engine running. Special winter fuels may be available for engine operation at temperatures below 0°C (32°F). These fuels have a lower viscosity and limit wax formation.

Cleaning the Machine

Introduction

Clean the machine using water and or steam. Do not allow mud, debris etc. to build upon the machine.

T3-024

Before carrying out any service procedures that require components to be removed:

- 1 Cleaning must be carried out either in the area of components to be removed or, in the case of major work, or work on the fuel system, the whole engine and surrounding machine must be cleaned.
- 2 When cleaning is complete move the machine away from the wash area, or alternatively, clean away the material washed from the machine.

Important: When removing components be aware of any dirt or debris that may be exposed. Cover any open ports and clean away the deposits before proceeding.

Detergents

Avoid using full strength detergent - always dilute detergents as per the manufacturer's recommendations, otherwise damage to the paint finish may occur.

Always adhere to local regulations regarding the disposal of debris created from machine cleaning.

Pressure Washing and Steam Cleaning

CAUTION

Never use water or steam to clean inside the cab. The use of water or steam could damage the on-board computer and render the machine inoperable. Remove dirt using a brush or damp cloth.

8-3-4-8

- 1 Park the machine on level ground. Operate the controls to slew the cab around across the tracks.

CAUTION

The engine or certain components could be damaged by high pressure washing systems; special precautions must be taken if the engine is to be washed using a high pressure system.

Ensure that the alternator, starter motor and any other electrical components are shielded and not directly cleaned by the high pressure cleaning system.

ENG-3-3

Important: Do not aim the water jet directly at bearings, oil seals or electrical and electronic components such as the engine electronic control unit (ECU), alternator or fuel injectors.

Use a low pressure water jet and brush to soak off caked mud or dirt.

Use a pressure washer to remove soft dirt and oil.

Note: The machine must always be greased after pressure washing or steam cleaning.

Cleaning the Tracks

WARNING

If two people are doing this job make sure that the person operating the controls is a competent operator. If the wrong control lever is moved, or if the controls are moved violently, the other person could be killed or injured.

If you will be working with another person, make sure that you both understand what is to be done. Learn and use the recognised signalling procedures. Do not rely on shouting - he will not hear you.

To clean the tracks, you must turn them. When the tracks are turning, keep clear of rotating parts. Before starting this job, make sure that you have no loose clothing (cuffs, ties etc.) which could get caught in moving parts. Keep people not involved with this job well away!

MD-3-3-2

Lower the bucket to the ground.

- 2 Operate the controls to push the boom down so that the track nearest the bucket is lifted clear of the ground.

WARNING

Rotating the tracks off the ground may cause stones and other debris to be thrown with considerable force. If you are on the outside, keep well clear. Keep other people well clear.

8-3-5-8

- 3 Operate the controls to rotate the track which is off the ground. Rotate it one way and then the other to shake off the mud. If necessary the person outside may use water from a hose to help loosen sticky material.
- 4 When the track is clean stop the rotation. Inspect the track, rollers sprockets and idler wheels for damage or oil leaks. Replace any damaged parts. If in doubt consult your JCB Dealer.
- 5 Operate the controls slowly to lower the track to the ground.
- 6 Operate the controls to position the bucket on the other side of the machine so that steps 2 to 5 can be repeated for the other track.

Checking for Damage

T3-013

- 1 Inspect steelwork for damage. Note damaged paintwork for future repair.
- 2 Make sure all pivot pins are correctly in place and secured by their locking devices.
- 3 Ensure that the steps and handrails are undamaged and secure.
- 4 Check for broken or cracked window glass. Replace damaged items.
- 5 Check all bucket teeth for damage and security.
- 6 Check all lamp lenses for damage.
- 7 Inspect the tyres for damage and penetration by sharp objects.
- 8 Check that all safety decals are in place and undamaged. Fit new decals where necessary.

Seat Belt

Checking the Seat Belt Condition and Security

T3-008

WARNING

When a seat belt is fitted to your machine replace it with a new one if it is damaged, if the fabric is worn, or if the machine has been in an accident. Fit a new seat belt every three years.

2-3-1-7_1

Inspect the seat belt for signs of fraying and stretching. Check that the stitching is not loose or damaged. Check that the buckle assembly is undamaged and works correctly.

Check that the belt mounting bolts are undamaged, correctly fitted and tightened.

Checking the Cab/Canopy Frame

WARNING

Modified and wrongly repaired cab frames are dangerous. Do not modify the cab frame. Do not attempt to repair the cab frame. If the cab frame has been in an accident, do not use the machine until the structure has been inspected and repaired. This must be done by a qualified person. For assistance, contact your JCB dealer. Failure to take these precautions could result in death or injury to the operator.

MD-3-1-4

- 1 Check the cab/canopy frame for damage.
- 2 Check that all the mounting bolts are installed and undamaged.
- 3 Check that the bolts are tight.

Greasing

Introduction

T3-028

You must grease the machine regularly to keep it working efficiently. Regular greasing will also lengthen the machine's working life. Refer to the **Service Schedule** for the correct intervals.

Note: *The machine must always be greased after pressure washing or steam cleaning.*

Greasing should be done with a grease gun. Normally, two strokes of the gun should be sufficient. Stop greasing when fresh grease appears at the joint. Use only the recommended type of grease. Do not mix different types of grease, keep them separate.

In the following illustrations, the grease points are numbered. Count off the grease points as you grease each one. Refit the dust caps after greasing.

Note: *Where applicable, refer to the manufacturers manual for instructions on the maintenance of optional attachments.*

Pivot Pins

WARNING

You will be working close into the machine for these jobs. Lower the attachments if possible. Remove starter key and disconnect the battery. This will prevent the engine being started.

8-3-1-3

For the types of grease to use at each point, ⇒ [Fluids, Lubricants and Capacities \(□ 3-10\)](#). Do not mix different types of grease, keep them separate.

*Note: Some optional attachments may need greasing more often. See **Optional Attachments**.*

- A Dipper ram pivot pin
- B Bucket ram pivot pin
- C Bucket pivot pin
- D Boom ram pivot pin
- E Kingpost ram pivot pin
- F Swing ram pivot pin
- G Dozer ram pivot pin

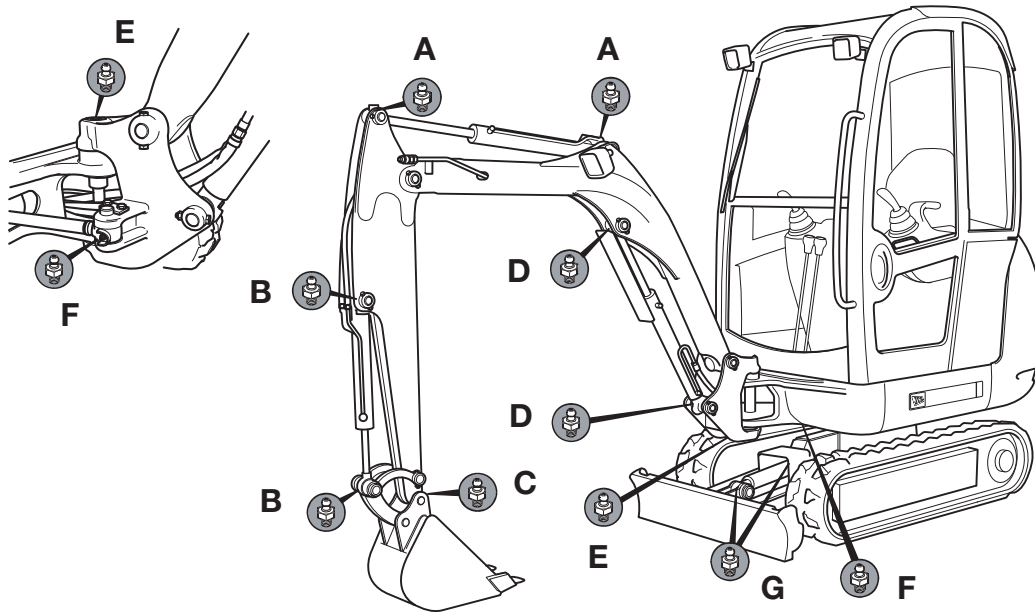

Fig 1.

Every 50 Hours

Slew Ring Bearings

WARNING

Do not overgrease the slew ring as this will result in the displacement of the grease seal.

8-2-9-35

Ensure the slew ring is kept full of grease. With the cab in the straight ahead position as shown, the grease point **A** is located on the front of the slew ring.

To ensure full distribution of the grease, use the following procedure:

- 1 Grease in, using 4 strokes of the grease gun. Rotate 180°.
- 2 Grease in, using 4 strokes of the grease gun. Rotate 180°.
- 3 Grease in using 4 strokes of the grease gun.

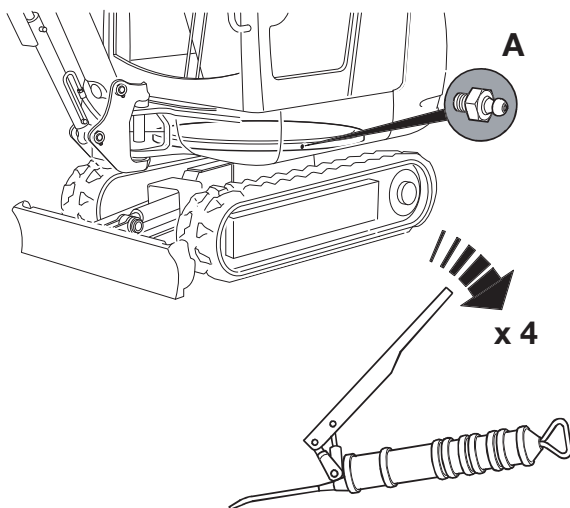

Fig 2.

Every 1000 Hours

Slew Ring Gear Teeth

WARNING

Slew Pinion Grease

JCB Slew Pinion Grease is harmful as it contains bitumen compounds 2811. Excessive contact may lead to dermatitis or skin cancer. Always use a barrier cream or wear gloves; wash contaminated skin thoroughly with soap and water. In the event of eye contact, immediately wash with plenty of water and seek medical advice.

8-1-1-7

WARNING

Soft Ground

A machine can sink into soft ground. Never work under a machine on soft ground.

INT-3-2-4

WARNING

Jacking

A machine can roll off jacks and crush you. Do not work under a machine supported only by jacks.

8-3-5-7

- 1 Raise the machine and support the undercarriage.
- 2 Stop the engine and remove the starter key.
- 3 Remove bolts **A** and plate **B** in the underside of the undercarriage. → [Fig 3. \(□ 3-23\)](#)
- 4 Apply the grease to the pinion using the applicator. → [Fluids, Lubricants and Capacities \(□ 3-10\)](#).
- 5 Start the engine and rotate the mainframe fully twice.
- 6 Stop the engine and remove the key.

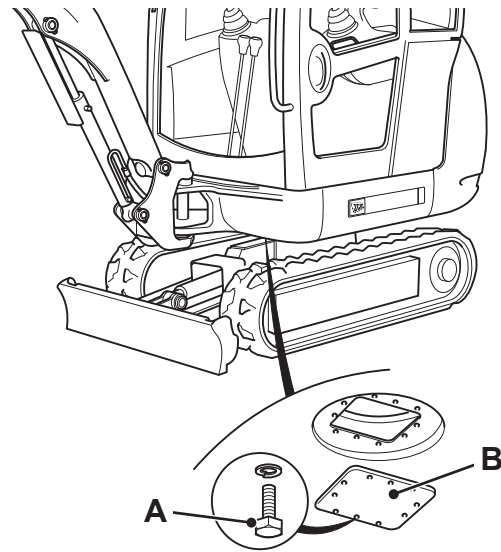

Fig 3.

- 7 Repeat step 4 as necessary.
- 8 Refit the plate **B** using bolts **A**.
- 9 Lower the machine to the ground.

Electrical System

Battery

Battery Cover

The battery is located on the right side of the engine compartment. Remove the battery cover if fitted.

Battery Disconnection/Connection

T3-019_3

WARNING

Keep metal watch straps and any metal fasteners on your clothes, clear of the positive (+) battery terminal. Such items can short between the terminal and nearby metal work. If it happens you can get burned.

5-2-2-4

Disconnection

- 1 Get access to the battery. See **Access Panels**.
- 2 Remove the leads. Disconnect the earth (-) terminal first.

Connection

- 1 Check the battery.
 - a If the terminal is dirty, clean the post.

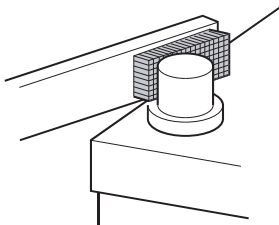

Fig 4.

- b If the terminal post is corroded and generates white powder wash the terminal with hot water. If considerable corrosion is detected, clean with a wire brush or abrasive paper.

- c After cleaning, apply a thin coat of petroleum jelly to the terminal.

- 2 Re-connect the leads. Connect the earth (-) terminal last.
- 3 Close and lock the access panels.

Checking the Electrolyte Level

T3-020_2

Maintenance free batteries used in normal temperate climate applications should not need topping up. However,

in certain conditions (such as prolonged operation at tropical temperatures or if the alternator overcharges) the electrolyte level should be checked as described below.

- 1 Get access to the battery. See **Access Panels**.
- 2 Disconnect and remove battery. See **Battery Disconnection/Connection**.

WARNING

Do not top the battery up with acid. The electrolyte could boil out and burn you.

2-3-4-6

- 3 Remove covers **A**. Look at the level in each cell. The electrolyte should be 6 mm (1/4 in) above the plates. Top up if necessary with distilled water or de-ionized water.

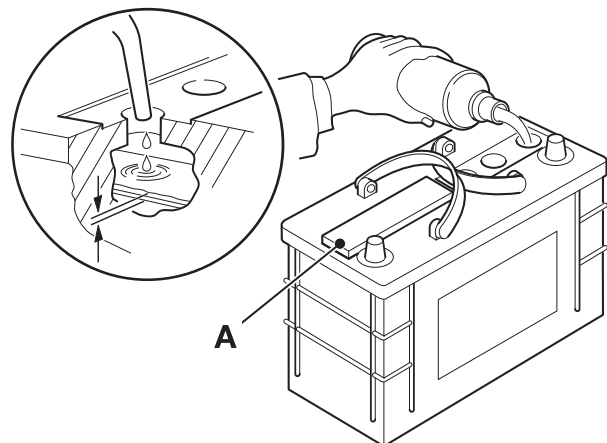

Fig 5.

- 4 Refit battery.
- 5 Close and lock the access panels.

Jump Starting the Engine

WARNING

In temperatures below freezing, the battery electrolyte may freeze if the battery is discharged or poorly charged. Do not use a battery if its electrolyte is frozen. To prevent the battery electrolyte from freezing, keep the battery at full charge.

If you try to charge a frozen battery or jump-start and run the engine, the battery could explode.

Batteries produce a flammable gas, which is explosive; do not smoke when checking the electrolyte levels.

When jump-starting from another vehicle, make sure that the two vehicles do not touch each other. This prevents any chance of sparks near the battery.

Switch off all circuits which are not controlled by the starter switch.

Do not connect the booster (slave) supply directly across the starter motor.

Use only sound jump leads with securely attached connectors. Connect one jump lead at a time.

The machine has a negative earth electrical system. Check which battery terminal is positive (+) before making any connections. Keep metal watch straps and jewellery away from the jump lead connectors and the battery terminals - an accidental short could cause serious burns and damage equipment. Make sure you know the voltage of the machine. The booster (slave) supply must not be higher than that of the machine. Using a higher voltage supply will damage your machine's electrical system. If you do not know the voltage of your booster (slave) supply, then contact your JCB dealer for advice. Do not attempt to jump-start the engine until you are sure of the voltage of the booster (slave) supply.

8-2-7-4

Note: Follow the instructions on this and the following page to start the engine using booster cables. Your machine has a 12V starting system. The negative (-) terminal on the battery is connected to frame earth.

DANGER

Before lowering the attachments to the ground, make sure that the machine and the area around it are clear of other people. Anyone on or close to the machine could fall and be crushed by the attachments, or get caught in the linkages.

2-2-3-4

- 1 Lower the Attachments to the Ground.

Lower the excavator bucket and dozer to the ground, if they are not already there. They will lower themselves under their own weight when you operate the control. Operate the control carefully to control the rate of descent.
- 2 Set all switches in the cab to 'OFF'.
- 3 Gain access to the battery.
 - a Open the engine cover.
 - b The battery is located on the right side of the engine compartment.
- 4 Connect the Booster Cables
 - a Connect the positive booster cable to the positive (+) terminal on the machine battery. Connect the other end of this cable to the positive (+) terminal of the booster supply.
 - b Connect the negative (-) booster cable to a good frame earth on the machine, away from and below the battery.

Note: A good frame earth is part of the machine frame, free from paint and dirt. Do not use a pivot pin for an earth.
- 5 Do the pre-start checks.

See Before Starting the Engine, Operation Section.
- 6 Start the engine.

See Starting the Engine, Operation Section.
- 7 Disconnect the Booster Cables
 - a Disconnect the cable from the machine frame earth, then disconnect it from the booster supply.
 - b Disconnect the positive booster cable from the positive (+) terminal on the battery, then disconnect it from the booster supply.
- 8 Close the engine cover.

Fuses

⚠ CAUTION

Fuses

Always replace fuses with ones of correct ampere rating to avoid electrical system damage.

8-3-3-5

The electrical circuits are protected by fuses. The fuse box **A** is located above the battery in the engine bay. ⇒ [Fig 6.](#) (□ 3-26). If a fuse blows, find out why before fitting a new one.

Fuse	Circuit	Rating
1	Engine Stop	5A
2	Servo Control, Instruments, Two Speed Tracking	5A
3	Windscreen Wiper	15A
4	Blower	15A
5	Boom Light	7.5A
6	Work Lights	15A
7	Horn, Interior Light, Aux. Power Socket	15A
8	Beacon	10A
9	Main Fuse	80A

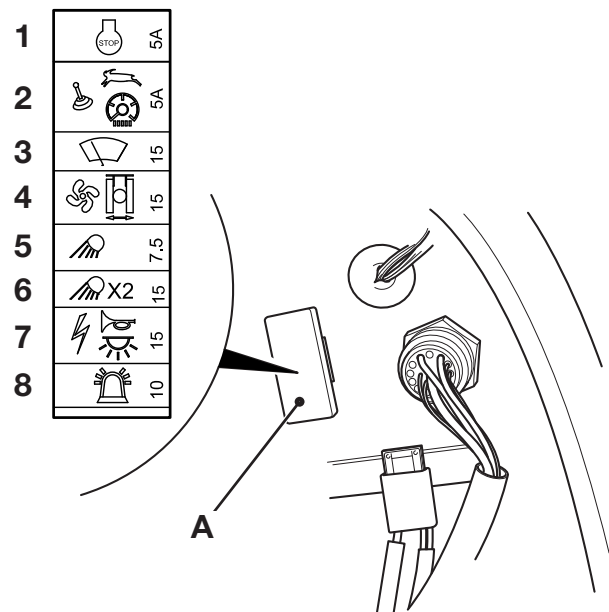

Fig 6.

Bulbs

Bulb	Rating
Cab lights	18W
Working lights	55W
Warning lights	3W

Engine

Checking the Oil Level

- 1 Park the machine on level ground. Lower the excavator and dozer to the ground.
- 2 Stop the engine and remove starter key.
- 3 Lower the engine cover. Allow time for the oil to drain back into the engine sump before taking a reading. If insufficient time is given a false low reading may be recorded which will result in overfilling the engine.
- 4 Withdraw dipstick and wipe clean, re-insert fully into tube and withdraw to check level. The correct level will show the oil at the top of the hatched area of the dipstick **A**. If necessary add oil slowly through the filler **B**. Replace filler cap securely. Use only the recommended oil. [⇒ Fluids, Lubricants and Capacities \(3-10\)](#).

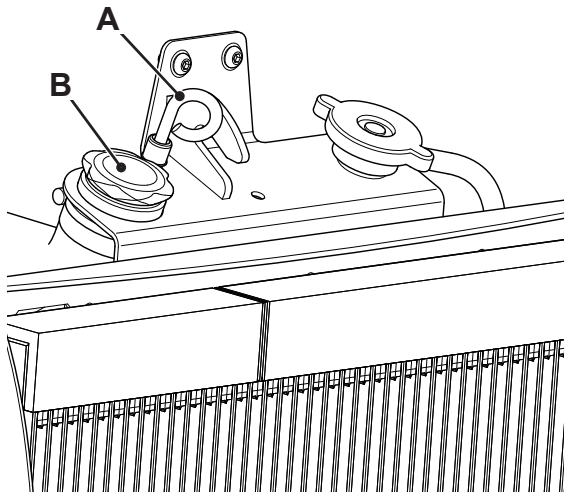

Fig 7.

Changing the Oil and Filter

WARNING

Hot oil and engine components can burn you. Make sure the engine is cool before doing this job.

Used engine crankcase lubricants contain harmful contaminants. In laboratory tests it was shown that used engine oils can cause skin cancer.

8-3-1-4

CAUTION

Keep your face away from the drain hole when removing the drain plug.

2-3-3-4

- 1 Remove sump protection plate.
- 2 Place a container beneath the engine (to catch the oil). ⇒ [Fluids, Lubricants and Capacities \(□ 3-10\)](#), for capacity. Remove the drain plug **A**. Let the oil drain out, then clean and refit the drain plug.

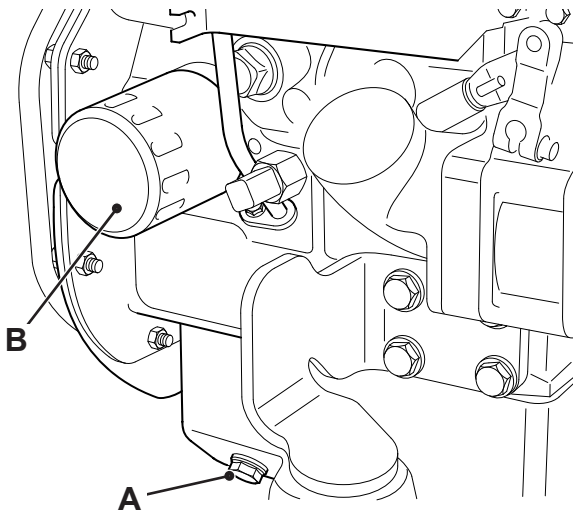

Fig 8.

CAUTION

The oil filter canister will contain some oil which could spill out when you remove the canister.

MD-3-2-1

- 3 Unscrew the filter canister **B**. If necessary use a chain or strap wrench. Clean the filter mounting face.

Smear the seal on the new filter canister with oil. Screw in the new canister - hand tight and then one quarter turn.

- 4 Fill the engine with new oil through the filler. ⇒ [Fluids, Lubricants and Capacities \(□ 3-10\)](#).
- 5 Wipe off any spilt oil. Check for leaks. Make sure that the filler cap is correctly refitted

Changing the Air Filter Element

- 1 Stop the engine and remove starter key.
- 2 Lower the engine cover.
- 3 Undo the two retaining clips holding the cover **A** and remove the element **B**. Do not tap or knock the element as you remove it.
- 4 Clean the inside of canister and dust valve.
- 5 Prior to fitting new element, smear the seal on the end of the element with grease. Temporarily insert the filter element into the canister ensuring its correct location. Withdraw the element and check that there is a continuous grease witness mark around the base of the canister. This shows that the canister has not been distorted which would allow unfiltered air to bypass the element. Refit the element and cover. Check all air hoses for condition and security.

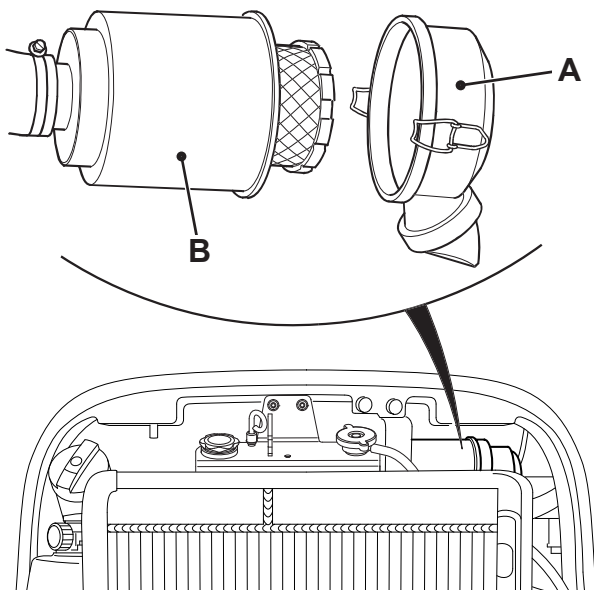

Fig 9.

Checking the Coolant Level

WARNING

The cooling system is pressurised when the coolant is hot. When you remove the cap, hot coolant can spray out and burn you. Make sure that the engine is cool before you work on the cooling system.

9-3-3-1_2

- 1 Park the machine on level ground, stop the engine and remove the starter key. Lower the engine cover and allow the engine to cool.
- 2 Observe the coolant fluid in the expansion bottle, the bottle **A** should be half full of coolant.
- 3 Top up the system, if required by carefully removing the expansion tube filler cap **B**, top up the level to the neck of the expansion tube.
- 4 Refit the filler cap **B** making sure that it is tight.

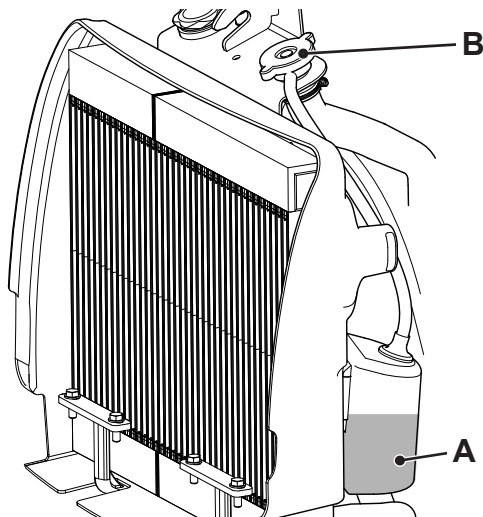

Fig 10.

Note: Water in the expansion bottle and not in the radiator indicates expansion bottle tube leaking or a non-sealing radiator pressure cap.

Changing the Coolant

⚠ CAUTION

Keep your face away from the cylinder block tap and the radiator drain plug when you drain the system.

MD-3-1-6

- 1 Park the machine on level ground, stop the engine and remove the starter key. Lower the engine cover and allow the engine to cool.
- 2 Carefully and slowly remove the radiator cap **A** allowing any trapped pressure to escape.
- 3 Undo the speed plug **B** on the cylinder block and let the coolant drain out. → [Fig 12. \(□ 3-31\)](#). Remove the bottom radiator hose **C** by unfastening at clip **D** and let the coolant drain out. Make sure the drain hole is not blocked.
- 4 Flush the system with clean water if necessary.

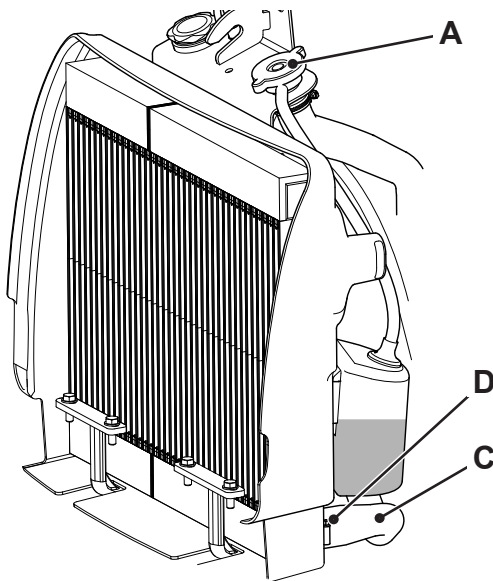

Fig 11.

- 5 Close the speed plug **B**. Refit bottom hose **C** and secure with hose clip **D**.

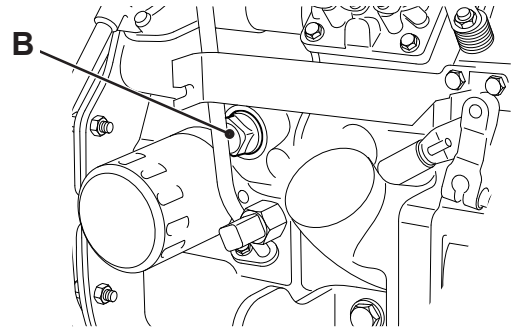

Fig 12.

- 6 Fill the system. Use the correct mix of clean, soft water and anti-freeze. → [Coolant Mixtures \(□ 3-11\)](#).
- 7 Refit the filler cap **A** making sure that it is tight.
- 8 Run the engine for a while, to raise the coolant to working temperature and pressure. Stop the engine. Check for leaks.

Adjusting the Fan Belt

- 1 Lower the engine cover
- 2 Check that there is 5mm (0.2in) slack midway between the crankshaft pulley and the alternator pulley.
- 3 If necessary loosen the alternator mounting bolts **B** and **C**.

Important: Excessive fan belt slack may result in damage to the engine timing cover.

- 4 Position the alternator so that there is 5mm (0.2in) slack at point **A**.
- 5 Tighten the alternator mounting bolts in the order **B** and **C**.

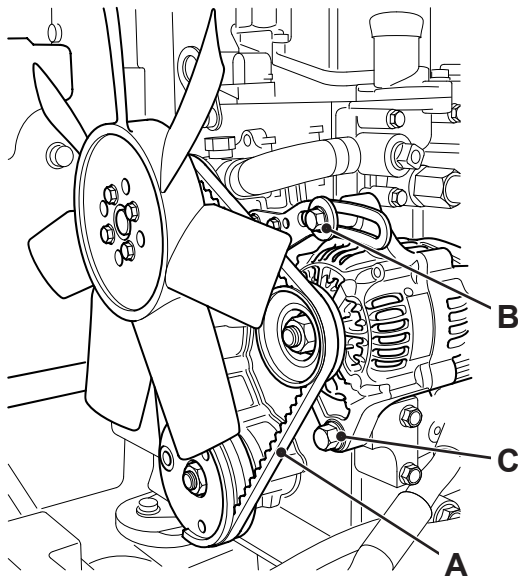

Fig 13.

Fuel System

Filling the Tank

CAUTION

Consult your fuel supplier or JCB distributor about the suitability of any fuel you are unsure of.

GEN-9-2

WARNING

Diesel Fuel

Diesel fuel is flammable; keep naked flames away from the fuel system. Do not smoke while refuelling or working on the fuel system. Do not refuel with the engine running. There could be a fire and injury if you do not follow these precautions.

INT-3-2-2_1

WARNING

Petrol

Do not use petrol in this machine. Do not mix petrol with the diesel fuel; in storage tanks the petrol will rise to the top and form flammable vapours.

INT-3-1-6

WARNING

Mobile Phones

Switch off your mobile phone before entering an area with a potentially explosive atmosphere. Sparks in such an area could cause an explosion or fire resulting in death or serious injury.

Switch off and do not use your mobile phone when refuelling the machine.

INT-3-3-9

CAUTION

Spilt fuel may cause skidding and therefore accidents. Clean any spilt fuel immediately.

Do not use fuel to clean the machine.

When filling with fuel, choose a well aired and ventilated area.

INT-2-2-12

At the end of every working day, fill the tank with the correct type of fuel. This will prevent overnight condensation from developing in the fuel. Do not fill the tank completely, leave some space to allow the fuel to expand.

We recommend that you lock the engine cover to prevent theft and tampering.

Draining the Fuel Filter/Sedimenter (Tier 2 Machines)

WARNING

Fuel oil is highly inflammable. Stop the engine immediately if a fuel leak is suspected. Completely wipe off any spilt fuel which could cause a fire.

8-3-4-3_1

- 1 Locate the sedimenter under the engine compartment to the left hand side of the machine.
- 2 Look in the bowl **A**. If there is any sediment in the bowl replace the fuel filter element. ⇒ [Replacing the Fuel Filter Element \(Tier 2 Machines\) \(□ 3-35\)](#). If there is water but no sediment, drain off the water by opening tap **B**.

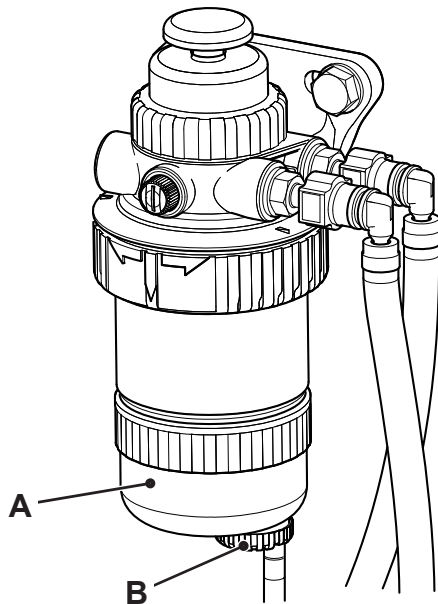

Fig 14.

Replacing the Fuel Filter Element (Tier 2 Machines)

WARNING

Fuel oil is highly inflammable. Stop the engine immediately if a fuel leak is suspected. Completely wipe off any spilt fuel which could cause a fire.

8-3-4-3_1

If the bowl **A** contains sediment carry out the following:

- 1 Disconnect the battery.
- 2 Drain the sediment bowl **A**. ⇒ [Draining the Fuel Filter/Sedimenter \(Tier 2 Machines\) \(□ 3-34\)](#).
- 3 Unscrew the filter and sediment bowl from the filter head **B**.
- 4 Unscrew the sediment bowl **A** from the filter **C** and wash the bowl. Use clean fuel.

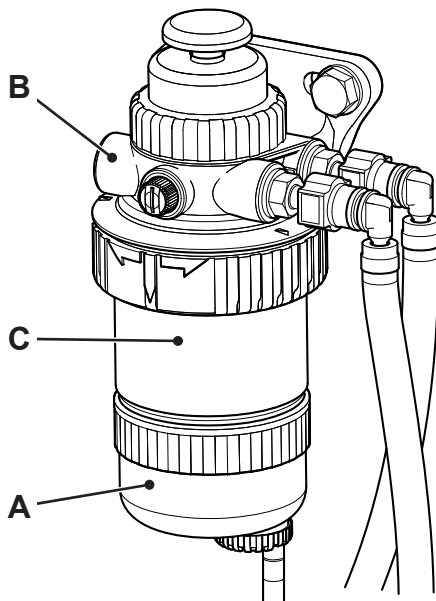

Fig 15.

- 5 Re-assemble new filter to bowl and refit to filter head **B**.
- 6 Bleed the system. ⇒ [Bleeding the System \(Tier 2 Machines\) \(□ 3-36\)](#).

Bleeding the System (Tier 2 Machines)

⚠ CAUTION

Running the engine with air in the system could damage the fuel injection pump. After maintenance, the system must be bled to remove any air.

2-3-3-11

⚠ WARNING

To bleed the injectors you must turn the engine. When the engine is turning, there are parts rotating in the engine compartment.

Before starting this job make sure that you have no loose clothing (cuffs, ties etc) which could get caught in rotating parts.

When the engine is turning, keep clear of rotating parts.

2-3-3-8

⚠ WARNING

Fuel oil is highly inflammable. Stop the engine immediately if a fuel leak is suspected. Completely wipe off any spilt fuel which could cause a fire.

8-3-4-3_1

- 1 Lower the engine cover.
- 2 To bleed air from the filter, slacken bleed screw **A**. Operate hand primer **B** until air free fuel flows from the union.
- 3 The fuel injection pump is self bleeding as the engine is cranked.

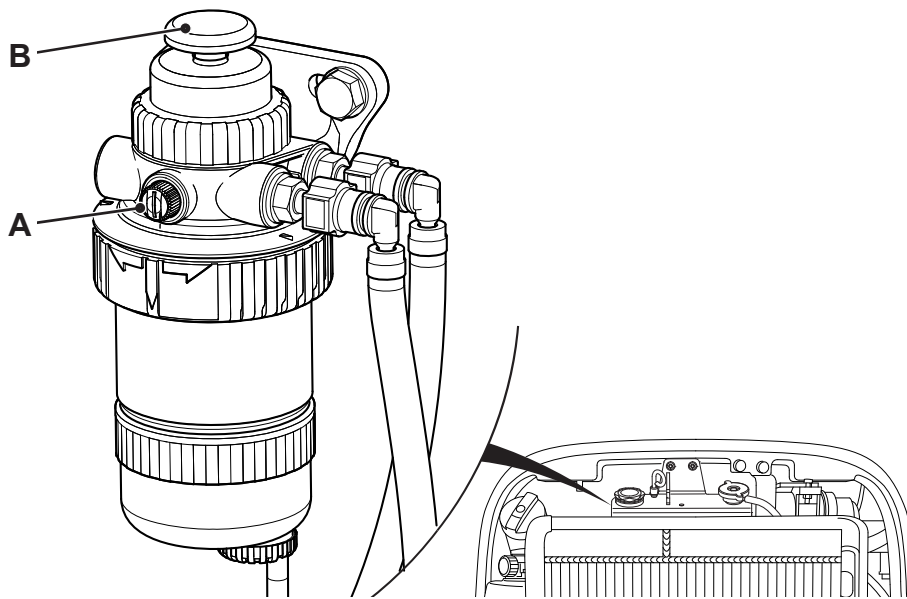

Fig 16.

Draining the Fuel Filter/Sedimenter (Tier 3 Machines)

WARNING

Fuel oil is highly inflammable. Stop the engine immediately if a fuel leak is suspected. Completely wipe off any spilt fuel which could cause a fire.

8-3-4-3_1

- 1 Locate the sedimenter under the engine compartment to the left hand side of the machine.
- 2 Look in the bowl **A**. If there is any sediment in the bowl replace the fuel filter element. ⇒ [Replacing the Fuel Filter Element \(Tier 3 Machines\) \(□ 3-38\)](#). If there is water but no sediment, drain off the water by opening tap **B**. ⇒ [Fig 17. \(□ 3-37\)](#)

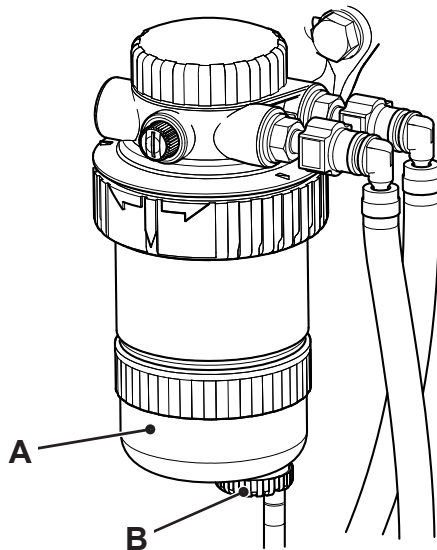

Fig 17.

Replacing the Fuel Filter Element (Tier 3 Machines)

WARNING

Fuel oil is highly inflammable. Stop the engine immediately if a fuel leak is suspected. Completely wipe off any spilt fuel which could cause a fire.

8-3-4-3_1

If the bowl **A** contains sediment carry out the following:

- 1 Disconnect the battery.
- 2 Drain the sediment bowl **A**. ⇒ [Draining the Fuel Filter/Sedimenter \(Tier 3 Machines\) \(□ 3-37\)](#).
- 3 Unscrew the filter and sediment bowl from the filter head **B**.
- 4 Unscrew the sediment bowl **A** from the filter **C** and wash the bowl. Use clean fuel. ⇒ [Fig 18. \(□ 3-38\)](#)

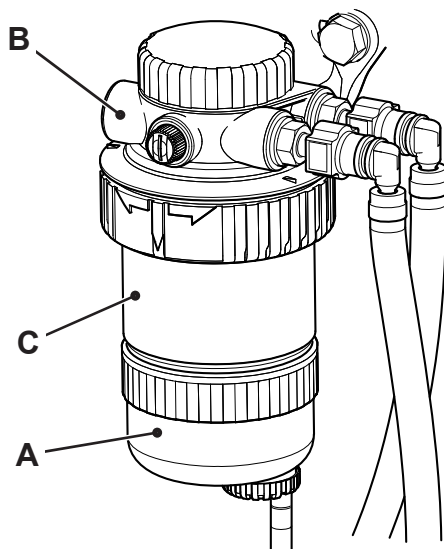

Fig 18.

- 5 Re-assemble new filter to bowl and refit to filter head **B**.
- 6 Bleed the system. ⇒ [Bleeding the System \(Tier 3 Machines\) \(□ 3-40\)](#).

Replacing the Fuel Pre Filter Element (Tier 3 Machines)

WARNING

Fuel oil is highly inflammable. Stop the engine immediately if a fuel leak is suspected. Completely wipe off any spilt fuel which could cause a fire.

8-3-4-3_1

- 1 Disconnect the battery.
- 2 Clamp the fuel hoses **A**. [⇒ Fig 19. \(□ 3-39\)](#)
- 3 Disconnect the fuel hose clips **B**.
- 4 Remove the bolt **C**, Collect the washer, Remove the fuel pre filter **D**
- 5 Install new filter in reverse order.
- 6 Bleed the system. [⇒ *Bleeding the System \(Tier 3 Machines\)* \(□ 3-40\).](#)

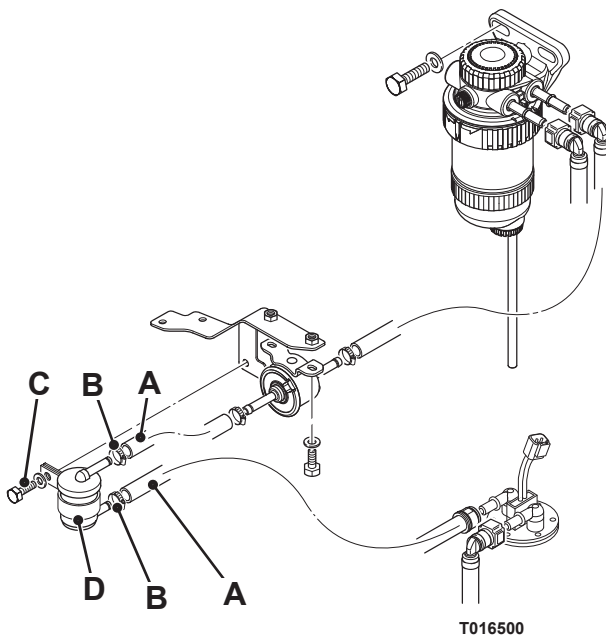

Fig 19.

Bleeding the System (Tier 3 Machines)

CAUTION

Running the engine with air in the system could damage the fuel injection pump. After maintenance, the system must be bled to remove any air.

2-3-3-11

WARNING

To bleed the injectors you must turn the engine. When the engine is turning, there are parts rotating in the engine compartment.

Before starting this job make sure that you have no loose clothing (cuffs, ties etc) which could get caught in rotating parts.

When the engine is turning, keep clear of rotating parts.

2-3-3-8

WARNING

Fuel oil is highly inflammable. Stop the engine immediately if a fuel leak is suspected. Completely wipe off any spilt fuel which could cause a fire.

8-3-4-3_1

- 1 Lower the engine cover.
- 2 To bleed air from the filter, slacken bleed screw **A**. Switch ignition to ON position (This will start the electric fuel pump).
- 3 Retighten bleed screw **A** when all air has been removed. [⇒ Fig 20. \(□ 3-40\)](#)

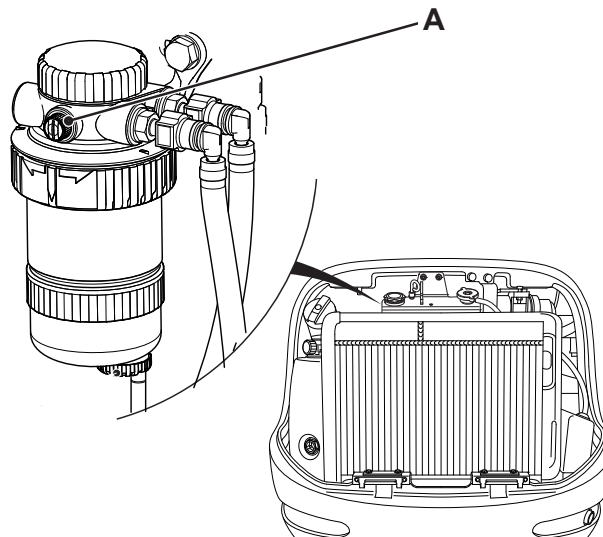

Fig 20.

Hydraulic System

WARNING

Fluid Under Pressure

Fine jets of fluid at high pressure can penetrate the skin. Keep face and hands well clear of fluid under pressure and wear protective glasses. Hold a piece of cardboard close to suspected leaks and then inspect the cardboard for signs of fluid. If fluid penetrates your skin, get medical help immediately.

INT-3-1-10_2

Checking and Adjusting the Fluid Level

1 Prepare the Machine

Park the machine on firm level ground with the rams positioned as shown. [⇒ Fig 21. \(□ 3-41\)](#). Stop the engine and remove the starter key.

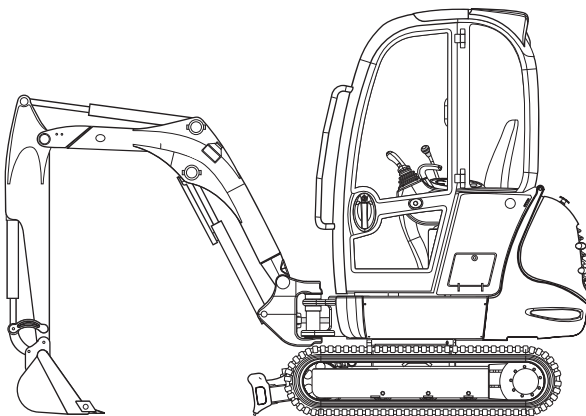

Fig 21.

2 Check the Level

Open the engine cover and check the level indicator **A**.

3 Top up fluid level if necessary

Remove filler cap **B** and spring **C**, add fluid. Ensure that only correct grade of fluid is used. [⇒ Fluids, Lubricants and Capacities \(□ 3-10\)](#).

4 Refit the filler cap and spring.

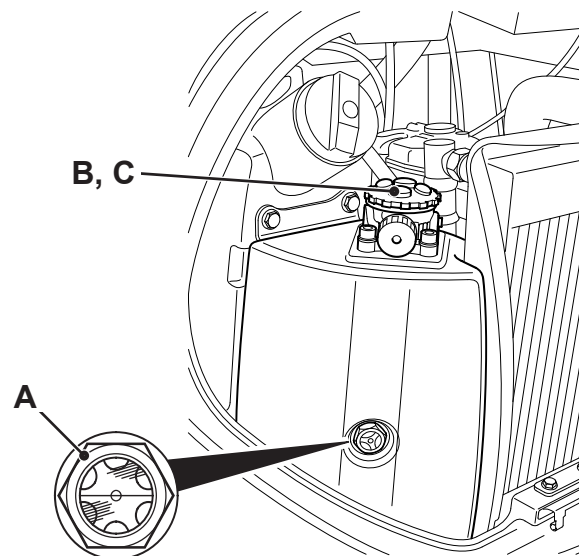

Fig 22.

Replacing the Hydraulic Filter

- 1 Open the engine cover and unscrew filler cap **B** and spring **C**.
- 2 Withdraw bypass valve **D**, cartridge filter **E** and seal **F**.
- 3 Clean all metal parts. Reassemble using new cartridge filter **E** and seal **F**.
- 4 Top up hydraulic fluid level through filter. ⇒ [Fluids, Lubricants and Capacities \(□ 3-10\)](#).
- 5 Replace bypass valve **D**, spring **C** and filler cap **B**.

Checking the Ram Piston Rods

Extend each ram fully, one at a time and visually examine for score marks, dents or similar defects. If a ram piston appears defective contact your service engineer or JCB dealer.

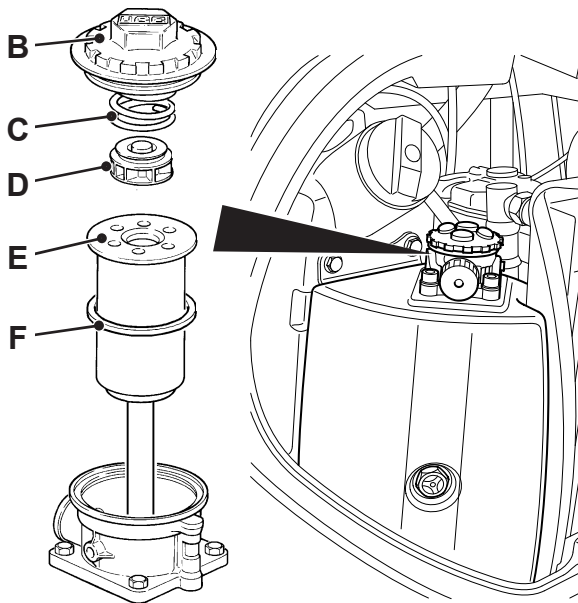

Fig 23.

Tracks and Running Gear

Checking the Track Gearbox Oil Level

- 1 Position the machine on firm level ground. Ensure that the gearbox plugs **A** and **B** are positioned as shown. Stop the engine and remove starter key.
- 2 Clean the area around the fill/level plug **A** and remove the plug, oil should be seen to be level with the hole.
- 3 Top up as necessary. [⇒ Fluids, Lubricants and Capacities \(□ 3-10\)](#). Clean and refit the plug, make sure it is tight.

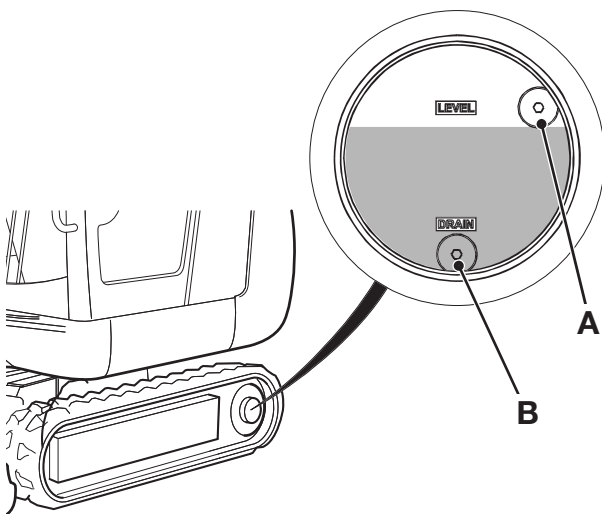

Fig 24.

Changing the Track Gearbox Oil

- 1 Position the machine on firm level ground.
- 2 Place a suitable container beneath the drain plug **B** to collect the oil.

CAUTION

Oil will gush from the hole when the drain plug is removed. Keep to one side when you remove the plug.

2-3-4-2

- 3 Remove level/filler plug **A**. Remove the drain plug **B**. Allow the oil to drain out. Wipe the drain plug clean. Make sure that you remove all metal particles. Refit the drain plug. Make sure it is tight.
- 4 Fill with new oil through the fill/level plug hole until oil runs from the hole. [⇒ Fluids, Lubricants and Capacities \(□ 3-10\)](#).
- 5 Run the machine, operate the track controls and then make sure there are no leaks.

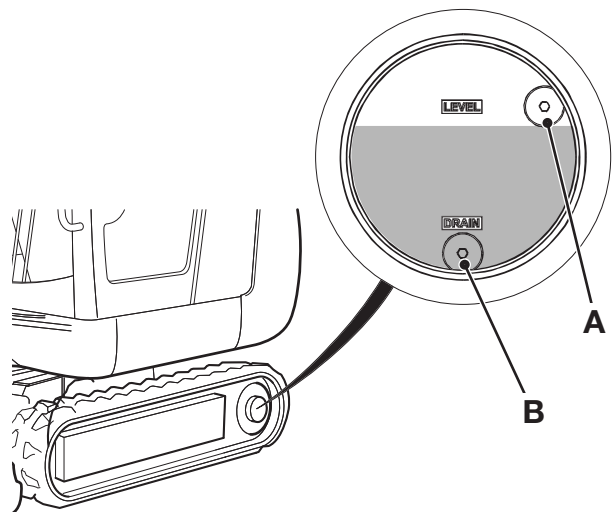

Fig 25.

Checking the Track Tension

CAUTION

Recoil unit servicing must only be carried out by JCB distributors. You could be killed or injured if you tamper with it.

8-3-3-4

1 Prepare the Machine

Park the machine on level ground. Run it backwards and forwards several times. Stop the machine after running it forwards.

Set the machine in the posture shown with the track to be tensioned raised from the ground and supported. [⇒ Fig 26. \(□ 3-45\).](#)

2 Check the Tension

Check that the tension measurement at **A** is 55mm (2.2in) for rubber tracks and 80mm (3.2in) for steel tracks.

CAUTION

Always make sure that the track tension measurement is not less than specified or severe strain to the track will result.

8-3-3-3

3 Adjust the track tension

a Check the tension clearance at **A** is 55mm (2.2in) for rubber tracks and 80mm (3.2in) for steel tracks.

b To tighten the track:

8014 - Remove the bolt **B** and remove cover plate **C**. Turn the adjusting screw **D** to obtain the correct tension.

Note: After adjustment the screw must be positioned so that the pin protruding from the head of the screw is pointing outwards in a horizontal attitude. This will allow the pin to locate correctly in the cover plate and prevent the adjusting screw from moving.

8016, 8018 - Pump grease through nipple **E** in adjusting screw **F** until track tension is correct. [⇒ Fluids, Lubricants and Capacities \(□ 3-10\).](#)

- c** Rotate track and re-check dimension **A**.
- d** To slacken the adjustment, slacken adjusting screw **D** or **E** until track tension is correct.
- e** Rotate track and re-check dimension **A**.
- f** Refit the cover plate if applicable. Lower the track to the ground.

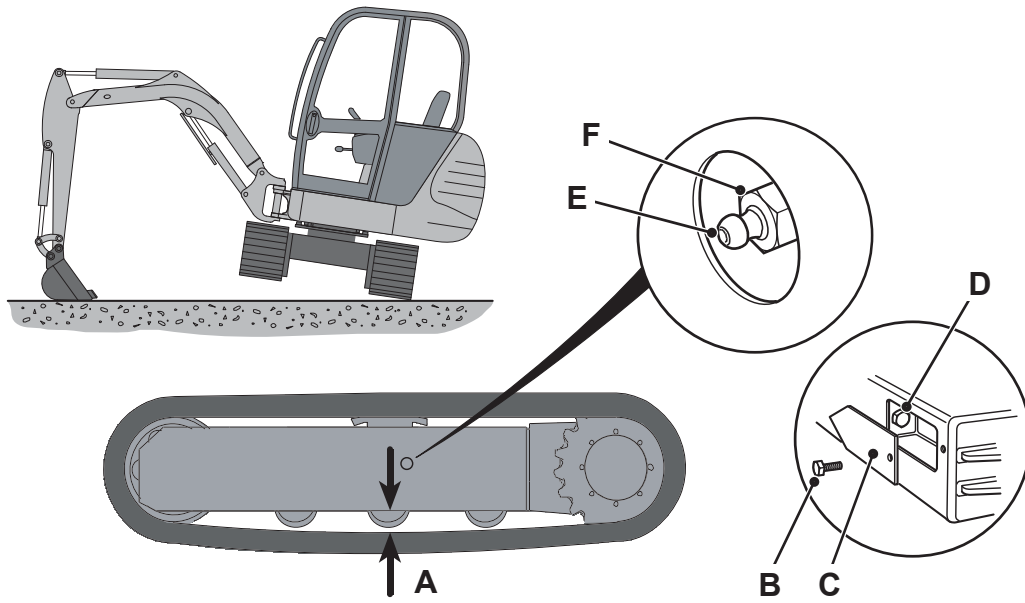

Fig 26.



Page left intentionally blank