

Product: Case ISUZU BB-4BG1T and BB-6BG1T Engine Service Repair Workshop Manual

Full Download: [https://www.arepairmanual.com/downloads/case-isuzu-bb-4bg1t-](https://www.arepairmanual.com/downloads/case-isuzu-bb-4bg1t-and-bb-6bg1t-engine-service-repair-workshop-manual/)

[and-bb-6bg1t-engine-service-repair-workshop-manual/](https://www.arepairmanual.com/downloads/case-isuzu-bb-4bg1t-and-bb-6bg1t-engine-service-repair-workshop-manual/)

SERVICE MANUAL BB-4BG1T and BB-6BG1T ISUZU ENGINES

Sample of manual. Download All 174 pages at:

<https://www.arepairmanual.com/downloads/case-isuzu-bb-4bg1t-and-bb-6bg1t-engine-service-repair-workshop-manual/>

Case

Cre 7-28760GB

Copyright © 2001 Case France

Printed in France

February 2001

Product: Case ISUZU BB-4BG1T and BB-6BG1T Engine Service Repair Workshop Manual

Full Download: <https://www.arepairmanual.com/downloads/case-isuzu-bb-4bg1t-and-bb-6bg1t-engine-service-repair-workshop-manual/>

Sample of manual. Download All 174 pages at:

<https://www.arepairmanual.com/downloads/case-isuzu-bb-4bg1t-and-bb-6bg1t-engine-service-repair-workshop-manual/>

TABLE OF CONTENTS	
SECTION	DESCRIPTION
1	General Information
2	Maintenance
3	Disassembly
4	Inspection and repair
5	Reassembly
6	Lubricating system
7	Cooling system
8	Fuel system
12	Troubleshooting
13	Special tools

SECTION 1

GENERAL INFORMATION

TABLE OF CONTENTS

ITEM	PAGE
General repair instructions	1-2
Notes on the format of this manual.....	1-2
Main data and specifications	1-6
External view	1-7
Tightening torque specifications	1-9
Angular nut and bolt tightening method.....	1-11
Major component mounting nuts and bolts.....	1-13
Identification	1-24

GENERAL REPAIR INSTRUCTIONS

1. Before performing any service operation with the engine mounted, disconnect the grounding cable from the battery.
This will reduce the chance of cable damage and burning due to short circuiting.
2. Always use the proper tool or tools for the job on hand.
Where specified use the specially designed tool or tools.
3. Use genuine CASE parts, referring to the CASE PARTS CATALOG for engine safety.
4. Never reuse cotter pins, gaskets, O-rings, lock washers, and self locking nuts. Discard them as you remove them. Replace them with new ones.
5. Always keep disassembled parts neatly in groups. This will ensure a smooth reassembly operation.
It is especially important to keep fastening parts separate. These parts vary in hardness and design, depending on their installation position.
6. All parts should be carefully cleaned before inspection or reassembly.
Oil ports and other openings should be cleaned with compressed air to make sure that they are completely free of obstructions.
7. Rotating and sliding part surfaces should be lubricated with oil or grease before reassembly.
8. If necessary, use sealing compound on gaskets to prevent leakage.
9. Nut and bolt torque specifications should be carefully followed.
10. Always release the air pressure from any machine-mounted air tank(s) before dismantling the engine or disconnecting pipes and hoses. To not do so is extremely dangerous.
11. Always check and recheck you work. No service operation is complete until you have done this.

NOTES ON THE FORMAT OF THIS MANUAL

This Service Manual is applicable to the BB-4BG1T and BB-6BG1T family of industrial diesel engines. Unless otherwise specified, these engines have common parts and components as well as data and specifications.

Illustrations used in this Service Manual are based on the BB-6BG1 and BB-6BG1T engines.

The BB-4BG1T engine and the BB-6BG1T engine are turbocharged.

1. Find the applicable section by referring to the Table of Contents at the beginning of the Manual.
2. Common technical data such as general maintenance items, service specifications, and tightening torques are included in the "General Information" section.
3. Each section is divided into sub-sections dealing with disassembly, inspection and repair, and reassembly.
The section ENGINE ASSEMBLY is an exception. This part is divided into three sections to facilitate quick indexing.
4. When the same servicing operation is applicable to several different units, the manual will direct you to the appropriate page.
5. For the sake of brevity, self-explanatory removal and installation procedures are omitted.
More complex procedures are covered in detail.

6. Each service operation section in this Service Manual begins with an exploded view of the applicable area. A brief explanation of the notation used follows.

Parts marked with an asterisk (*) are included in the repair kit.

Parts within a square frame are to be removed and installed as a single unit.

All parts within an irregularly shaped frame form a single assembly. They are considered to be a "major component".

Individual parts within the irregularly shaped frame are considered to be "minor components".

The number indicates the service operation sequence.

Removal of unnumbered parts is unnecessary unless replacement is required.

The "** Repair Kit" indicates that a repair kit is available.

The parts listed under "Reassembly Steps" or "Installation Steps" are in the service operation sequence.

The removal or installation of parts marked with a triangle (▲) is an important operation. Detailed information is given in the text.

Disassembly Steps - 2

<ul style="list-style-type: none"> 1. Water by-pass hose 2. Thermostat housing 3. Water pump ▲ 4. Injection nozzle holder 5. Glow plug and glow plug connector 6. Cylinder head cover ▲ 7. Rocker arm shaft and rocker arm 8. Push rod ▲ 9. Cylinder head 	<ul style="list-style-type: none"> 10. Cylinder head gasket ▲ 11. Crankshaft damper pulley with dust seal 12. Timing gear case cover 13. Timing gear cover 14. Timing gear oil pipe 15. Idler gear "B" end shaft ▲ 16. Idler gear "A" ▲ 17. Idler gear shaft
--	--

Inverted Engine

1-4 GENERAL INFORMATION

7. Below is a sample of the text of the Service Manual

Valve Guide Installation

1. Lubricate the valve guide outer face with engine oil.
2. Attach the installer to the valve guide.
3. Use a hammer to drive the valve guide into position from the cylinder head upper face.
4. Measure the height of the valve guide upper end from the upper face of the cylinder head.

Valve Guide Upper End Height (H)	14.1 (0.56)
----------------------------------	-------------

Note:
If the valve guide has been removed, both the valve and the valve guide must be replaced with new ones as a set.
Be absolutely sure to discard the used valves and valve guides.

This is the item shown in the illustration. It is marked with a triangle (▲) on the Major Components page.

Letters and numbers contained in a circle refer to the illustration.

Symbols indicate the type of service operation or step to be performed. A detailed explanation of these symbols follows.

Service data and specifications are given in this table.

8. The following symbols appear throughout this Service Manual. They indicate the type of service operation or step to perform.



Removal



Adjustment



Installation



Cleaning



Disassembly



Important Operation Requiring Extra Care



Reassembly



Specified Torque (Tighten)



Alignment (Marks)



Commercially Available Tool Use Required or Recommended



Directional Indication



Lubrication (Oil)



Inspection



Lubrication (Grease)



Measurement



Sealant Application

9. Measurement criteria are defined by the terms “standard” and “limit”.

A measurement falling within the “standard” range indicates that the applicable part or parts are serviceable.
“Limit” should be taken as an absolute value.

10. Components and parts are listed in the singular form throughout the Manual.

11. Directions used in this Manual are as follows:

Front: The cooling fan side of the engine viewed from the flywheel.

Right: The injection pump side of the engine.

Left: The exhaust manifold side of the engine.

Rear: The flywheel side of the engine.

Cylinder numbers are counted from the front of the engine.

The front cylinder is No. 1 and rear cylinder is No. 4 or No. 6.

The engine’s direction of rotation is counterclockwise as viewed from the flywheel.

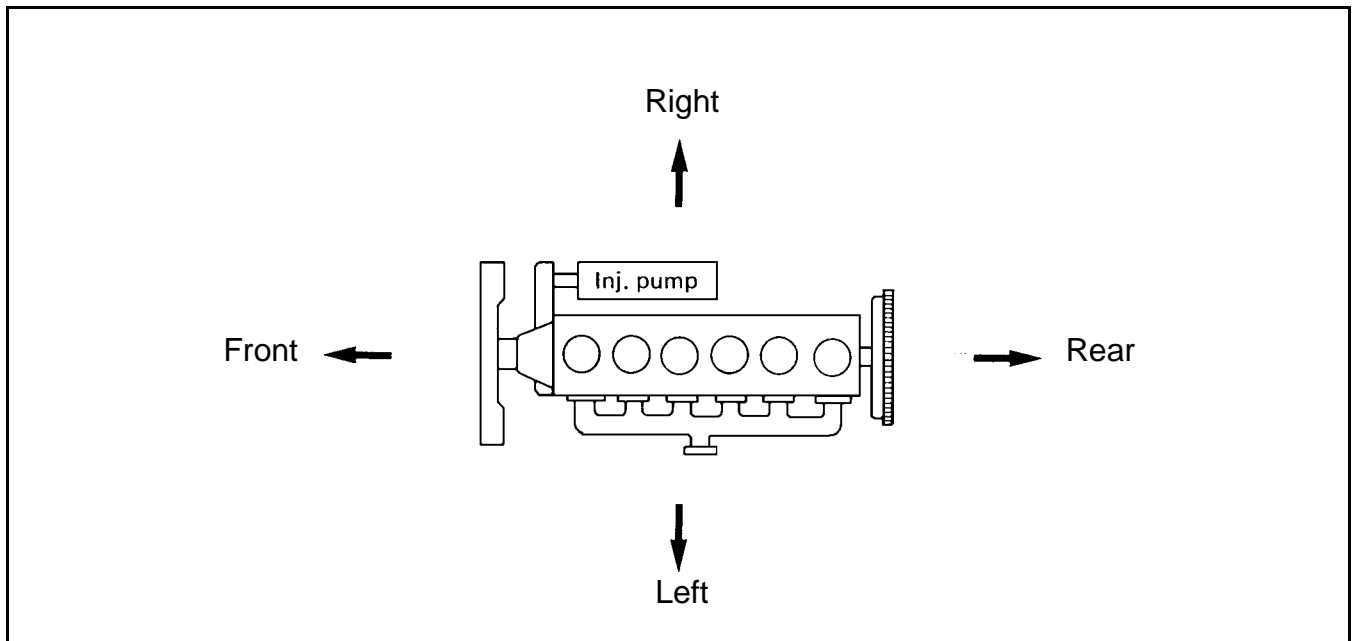

1-6 GENERAL INFORMATION

MAIN DATA AND SPECIFICATIONS

Note:

1. These specifications are based on the standard engine.
2. Specifications for items marked with an asterisk (*) will vary according to the type of equipment on which the engine is installed.

If you are unable to locate the data applicable to these specifications, please contact Isuzu Motors LTD through your machine supplier.

Item	Engine Model BB-4BG1T	Engine Model BB-6BG1T
Engine type	Water cooled, four cycle, vertical in-line overhead valve	
Combustion chamber type	Direct injection	
Cylinder liner type	Dry	
No. of cylinders - bore x stroke mm (in)	4 - 105 x 125 (4.13 x 4.92)	6 - 105 x 125 (4.13 x 4.92)
Total piston displacement cm ³ (cid)	4329 (264)	6494 (396)
Compression ratio	18 to 1	18 to 1
* Engine dimensions mm (in)	904 x 684.8 x 907	1204 x 762 x 961
Length x width x height	(36.6 x 27 x 35.7)	(47 x 30 x 37.8)
* Engine weight (Dry) kg (lb)	360 (794)	484 (1067)
Fuel injection order	1-3-4-2	1-5-3-6-2-4
Specified fuel	Diesel fuel (ASTM D975 No. 2D)	
Injection pump	In-line plunger, Bosch A type	In-line plunger, Bosch AD type
* Gouvernor	Mechanical, RSV type	
Injection nozzle	Multi hole	
Injection starting pressure kg/cm ² (psi)	181 (2630)	
Fuel filter type	Cartridge (spin-on)	
Water sediment decanter (if so equipped)	Sediment/water level indicating type	
Compression pressure kg/cm ² (psi)	31 (441)	
(When warm)	at 200 rpm at sea level	
Valve clearances (When cold)		
Intake mm (in)	0.40 (0.016)	
Exhaust mm (in)	0.40 (0.016)	
Lubrication method	Pressurized circulation	
Oil pump	Gear type	
Main oil filter type	Full flow, cartridge (spin-on)	Cartridge (spin-on)
* Lubricating oil volume lit. (US gal)	13 (3.4)	21.5 (5.68)
Oil cooler	Water cooled integral type	
Cooling method	Pressurized forced circulation	
Coolant volume (engine only) lit. (US gal)	8.5 (2.25)	12 (3.2)
Water pump	Belt driven impeller type	
Thermostat type	Wax pellet type	
* Generator V-A	24-40	
* Starter V-KW	24-4.5	
* Turbocharger manufacturer	MITSUBISHI	IHI
* Turbocharger model	TD04H	RHG6

EXTERNAL VIEW

Model BB-4BG1T

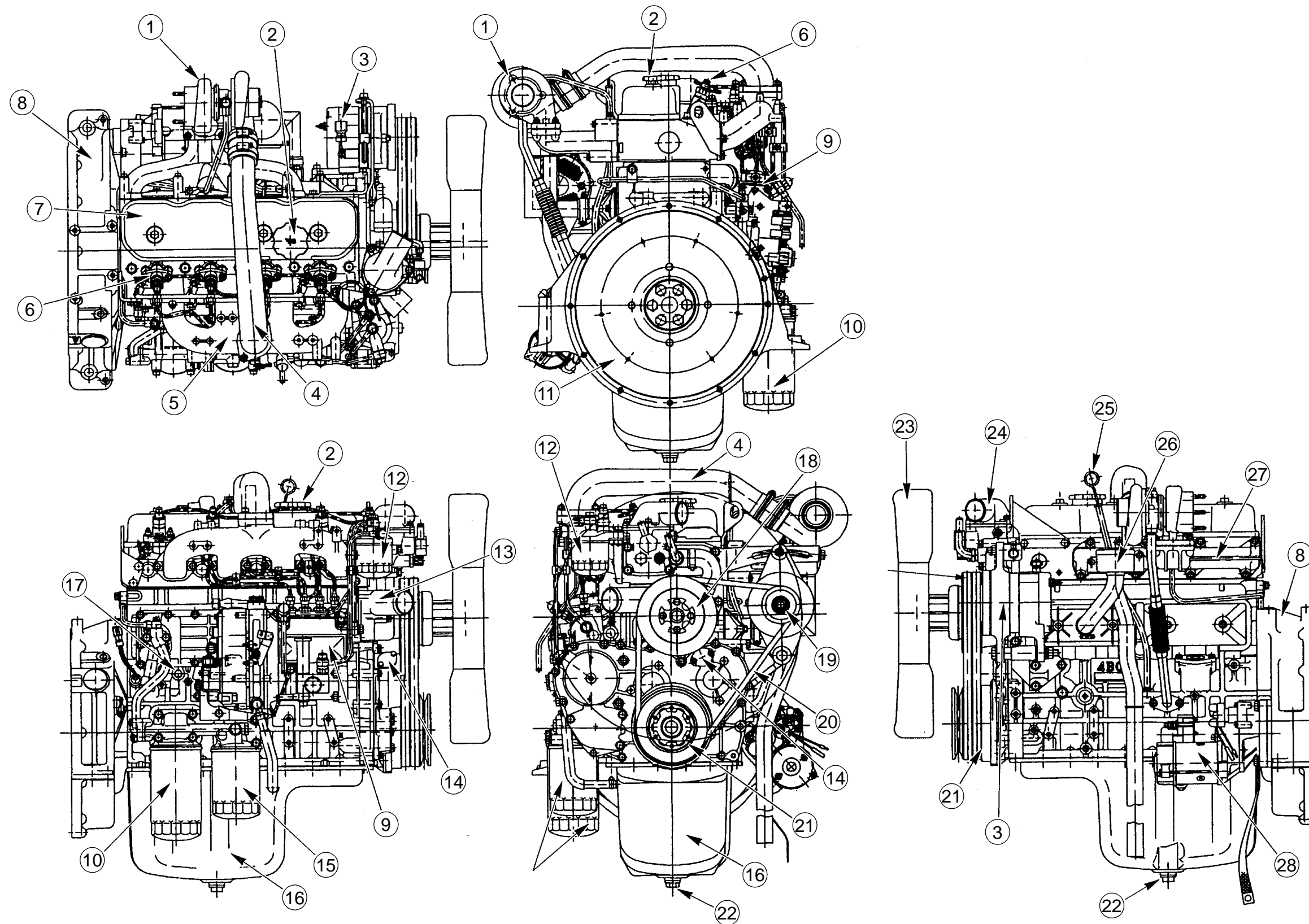

1. Turbocharger
2. Oil filler cap
3. Alternator
4. Intake pipe
5. Inlet manifold
6. Nozzle holder
7. Cylinder head cover
8. Flywheel housing
9. Injection pump
10. Partial oil filter
11. Flywheel
12. Fuel filter
13. Water pump
14. Check hole cover
15. Main oil filter
16. Oil pan
17. Water drain cock
18. Fan pulley
19. Alternator pulley
20. Fan belt
21. Crank pulley
22. Oil drain plug
23. Cooling fan
24. Thermostat housing
25. Dipstick
26. Air breather
27. Exhaust manifold

Model BB-6BG1T

EXTERNAL VIEW

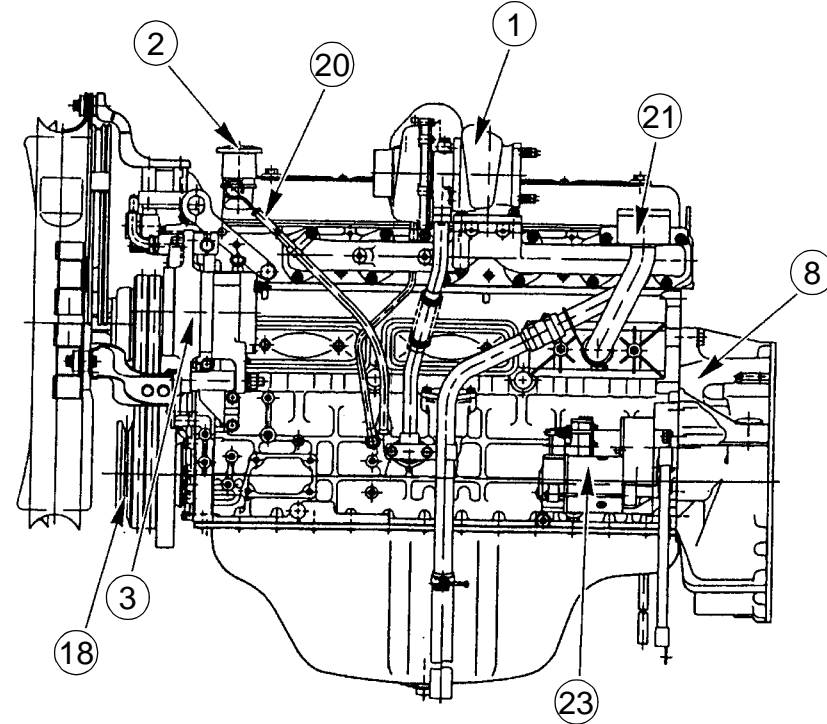
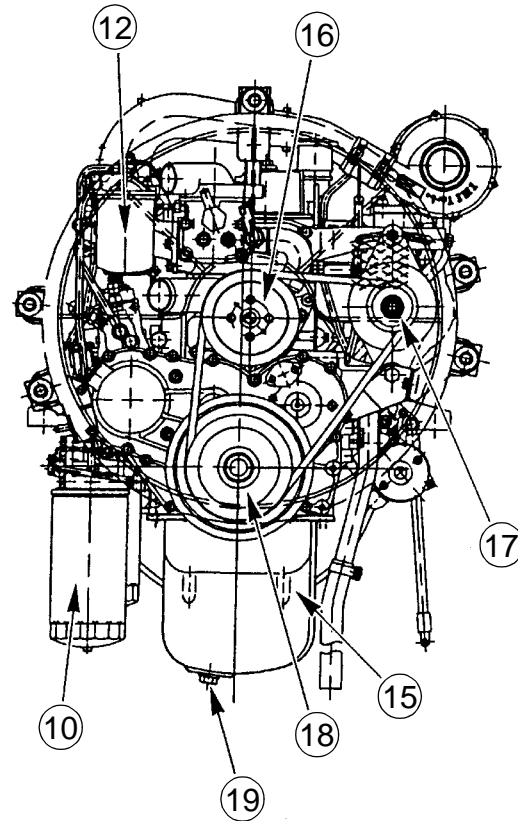
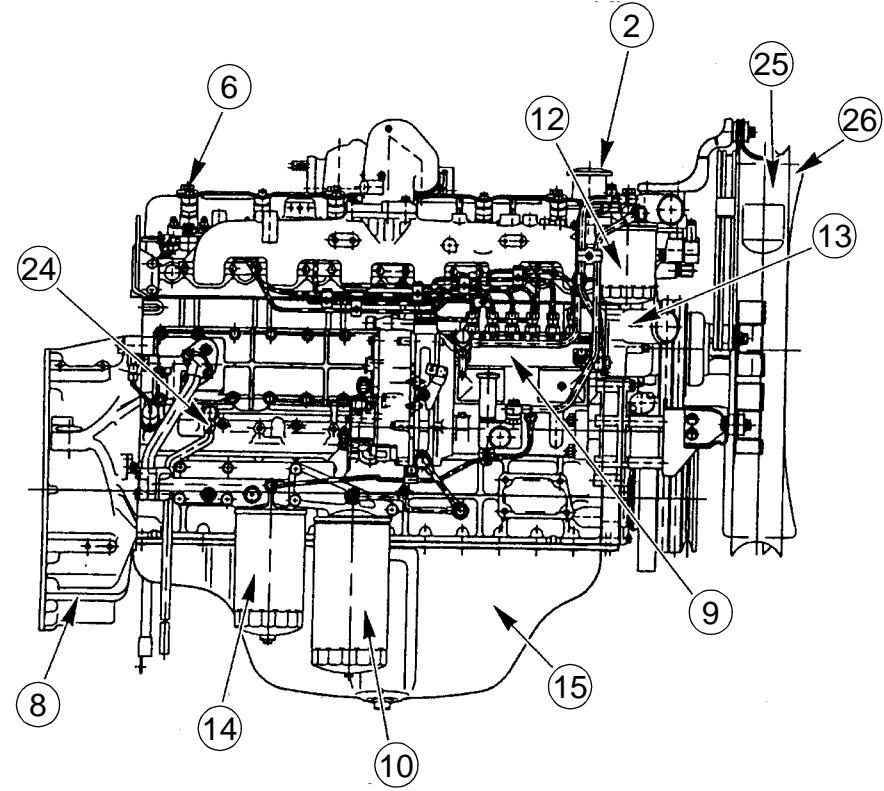
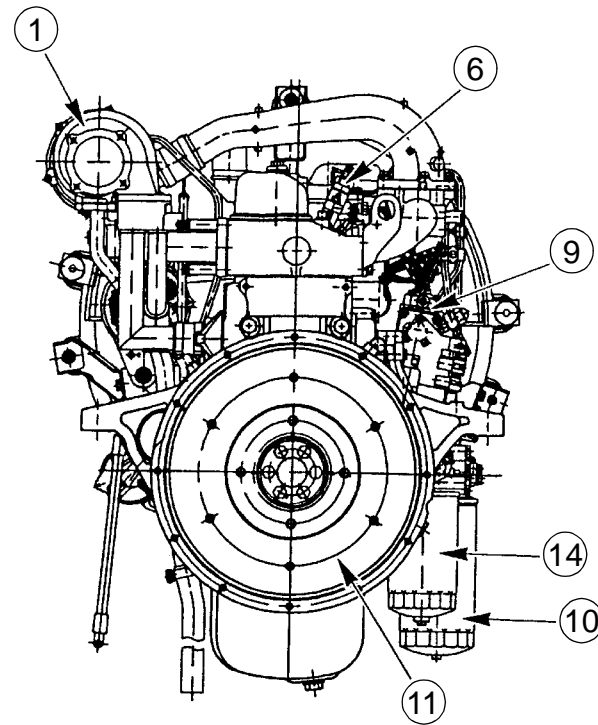
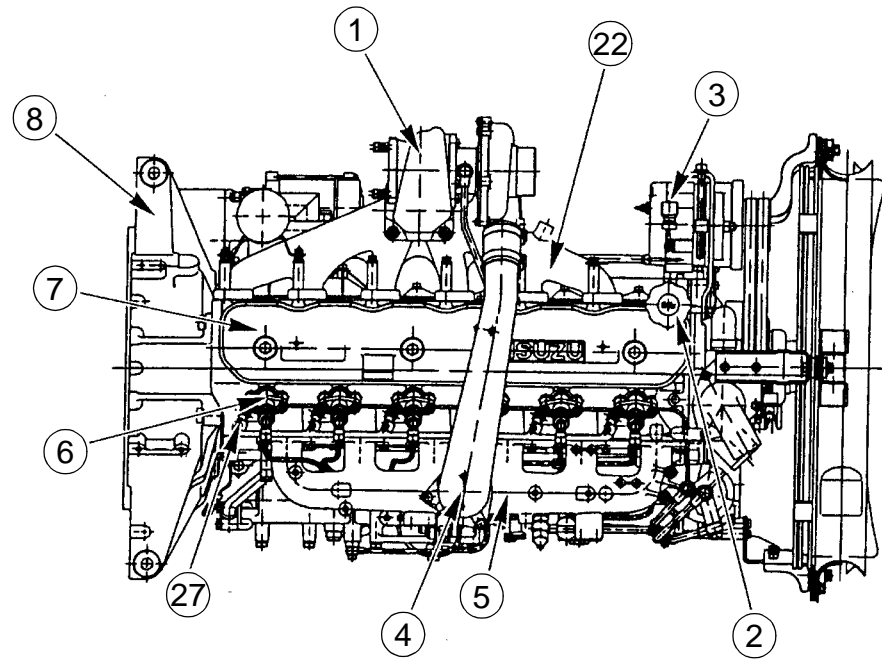









1. Turbocharger
2. Oil filler cap
3. Alternator
4. Intake pipe
5. Inlet manifold
6. Nozzle holder
7. Cylinder head cover
8. Flywheel housing
9. Injection pump
10. Partial oil filter
11. Flywheel
12. Fuel filter
13. Water pump
14. Main oil filter
15. Oil pan
16. Fan pulley
17. Alternator pulley
18. Crank pulley
19. Oil drain plug
20. Dipstick
21. Air breather
22. Exhaust manifold
23. Starter motor
24. Water drain plug
25. Fan guide
26. Cooling fan
27. Glow plug

TIGHTENING TORQUE SPECIFICATIONS

The tightening torque values given in the table below are applicable to the bolts unless otherwise specified.

STANDARD BOLT

Nm (kgf.m/lbft)

Bolt Identification Bolt Diameter x pitch (mm)				
				
M6 x 1.0	3.9-7.8 (0.4-0.8/2.9-5.8)	4.9-9.8 (0.5-1.0/3.6-7.2)		
M8 x 1.25	7.8-17.7 (0.8-1.8/5.8-13.0)	11.8-22.6 (1.2-2.3/8.7-16.6)		16.7-30.4 (1.7-3.1/12.3-22.4)
M10 x 1.25	20.6-34.3 (2.1-3.5/5.2-25.3)	27.5-46.1 (2.8-4.7/20.3-33.4)		37.3-62.8 (3.8-6.4/27.5-46.3)
M12 x 1.25	49.1-73.6 (5.0-7.5/36.2-54.2)	60.8-91.2 (6.2-9.3/44.8-67.3)		75.5-114.0 (7.7-11.6/55.7-83.9)
M14 x 1.5	76.5~115.0 (7.8~11.7/56.4~84.6)	93.2-139.0 (9.5-14.2/68.7-103.0)		114.0-0 (11.6-17.4/83.9-126.0)
M16 x 1.5	104.0-157.0 (10.6-16.0/76.7-115.7)	135.0-204.0 (13.8-20.8/99.8-150.0)		160.0-240.0 (16.3-24.5/118.0-177.0)
M18 x 1.5	151.0-226.0 (15.4-23.0/111.0-166.0)	195.0-293.0 (19.9-29.9/144.0-216.0)		230.0-345.0 (23.4-35.2/169.0-255.0)
M20 x1.5	206.0-310.0 (21.0-31.6/152.0-229.0)	270.0-405.0 (27.5-41.3/199.0-299.0)		317.0-476.0 (32.3-48.5/234.0-351.0)
M22 x 1.5	251.0-414.0 (25.6-42.2/185.0-305.0)	363.0-544.0 (37.0-55.5/268.0-401.0)		425.0-637.0 (43.3-64.9/313.0-469.0)
M24 x 2.0	359.0-540.0 (36.6-55.0/265.0-398.0)	431.0-711.0 (43.9-72.5/318.0-524.0)		554.0-831.0 (56.5-84.7/409.0-613.0)
*M10 x 1.5	19.6-33.4 (2.0-3.4/14.5-24.6)	27.5-45.1 (2.8-4.6/20.3-33.3)		36.3-59.8 (3.7-6.1/26.8-44.1)
*M12 x 1.75	45.1-68.7 (4.6-7.0/33.3-50.6)	56.9-84.4 (5.8-8.6/42.0-62.2)		71.6-107.0 (7.3-10.9/52.8-78.8)
*M14 x 2.0	71.6-107.0 (7.3-10.9/52.8-78.8)	88.3-131.0 (9.0-13.4/65.1-96.9)		107.0-160.0 (10.9-16.3/78.8-118.0)
*M16 x 2.0	100.0-149.0 (10.2-15.2/73.8-110.0)	129.0-194.0 (13.2-19.8/95.5-143.0)		153.0-230.0 (15.6-23.4/113.0-169.0)
*M18x2.5	151.0-226.0 (15.4-23.0/111.0-166.0)	196.0-294.0 (20.0-30.0/145.0-217.0)		231.0-346.0 (23.6-35.3/171.0-255.0)
*M20x2.5	190.0-286.0 (19.4-29.2/140.0-211.0)	249.0-375.0 (25.4-38.2/184.0-276.0)		293.0-440.0 (29.9-44.9/216.0-325.0)
*M22x2.5	218.0-328.0 (22.2-33.4/161.0-242.0)	338.0-507.0 (34.5-51.7/250.0-374.0)		394.0-592.0 (40.2-60.4/291.0-437.0)
*M24x3.0	338.0-507.0 (34.5-51.7/250.0-374.0)	406.0-608.0 (41.4-62.0/299.0-448.0)		521.0-782.0 (53.1-79.7/384.0-576.0)

An asterisk (*) indicates that the bolts are used for female threaded parts that are made of soft materials such as casting. Those shown in parentheses in the strength class indicate the classification by the old standard.

1-10 GENERAL INFORMATION

TIGHTENING TORQUE SPECIFICATIONS

The tightening torque values given in the table below are applicable to the bolts unless otherwise specified.

FLANGED HEAD BOLT

Nm (kgf.m/lb.ft)

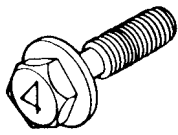
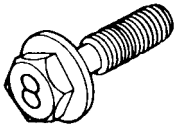
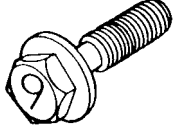
Nominal Size (dia. x pitch)	Bolt head marking		
			
M6 x 1	4.6-8.5 (0.5-0.9/3.6-6.5)	6.6-12.2 (0.6-1.2/4.3-8.7)	_____
M8 x 1.25	10.5-19.6 (1.1-2.0/8.0-14.5)	15.3-28.4 (1.6-2.9/11.6-21.0)	18.1-33.6 (2.1-3.4/15.2-25.0)
M10 x 1.25	23.1-38.5 (2.4-3.9/17.4-28.2)	35.4-58.9 (3.6-6.1/26.0-44.1)	42.3-70.5 (4.3-7.2/31.1-52.1)
*M10 x 1.5	22.3-37.2 (2.3-3.8/16.6-27.5)	34.5-57.5 (3.5-5.8/25.3-42.0)	40.1-66.9 (4.1-6.8/29.7-49.2)
M12 x 1.25	54.9-82.3 (5.6-8.4/40.1-60.8)	77.7-117.0 (7.9-11.9/57.1-86.1)	85.0-128.0 (8.7-13.0/62.9-94.0)
*M12 x 1.75	51.0-76.5 (5.2-7.8/37.6-56.4)	71.4-107.0 (7.3-10.9/52.8-78.8)	79.5-119.0 (8.1-12.2/58.6-88.2)
M14 x 1.5	83.0-125.0 (8.5-12.7/61.5-91.9)	115.0-172.0 (11.7-17.6/84.6-127.0)	123.0-185.0 (12.6-18.9/91.1-137.0)
*M14 x 2	77.2-116.0 (7.9-11.8/57.1-85.3)	108.0-162.0 (11.1-16.6/80.3-120.0)	116.0-173.0 (11.8-17.7/85.3-128)
M16 x 1.5	116.0-173.0 (11.8-17.7/85.3-128)	171.0-257.0 (17.4-26.2/26.0-190)	177.0-265.0 (18.0-27.1/130.0-196.0)
*M16 x 2	109.0-164.0 (11.2-16.7/81.0-121.0)	163.0-244.0 (16.6-24.9/120.0-180.0)	169.0-253.0 (17.2-25.8/124.0-187.0)

A bolt with an asterisk (*) is used for female screws of soft material such as cast iron.



ANGULAR NUT AND BOLT TIGHTENING METHOD

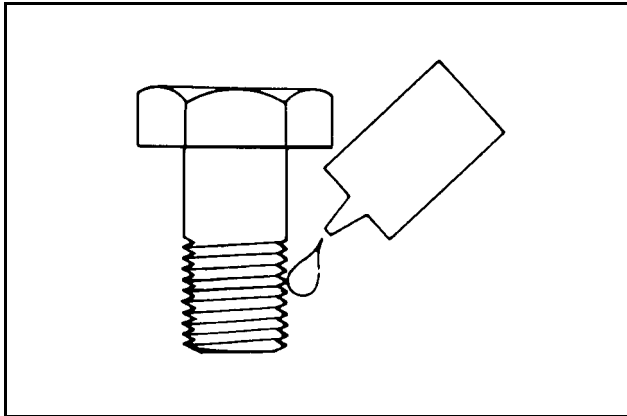

1. Carefully wash the nuts and bolts and to remove all oil and grease.



2. Apply a coat of molybdenum disulfide grease to the threads and setting faces of the nuts and bolts.

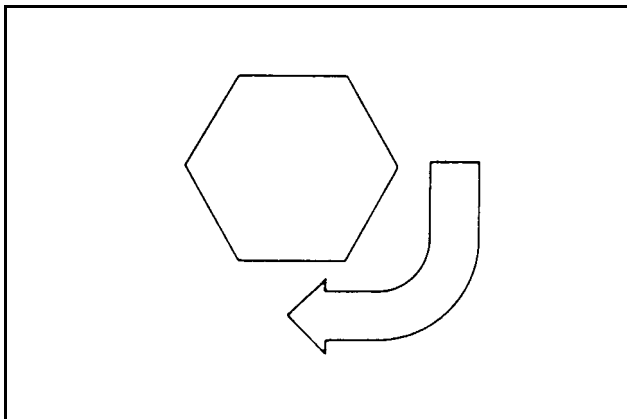

3. Tighten the nuts and bolts to the specified torque (snug torque) with a torque wrench.

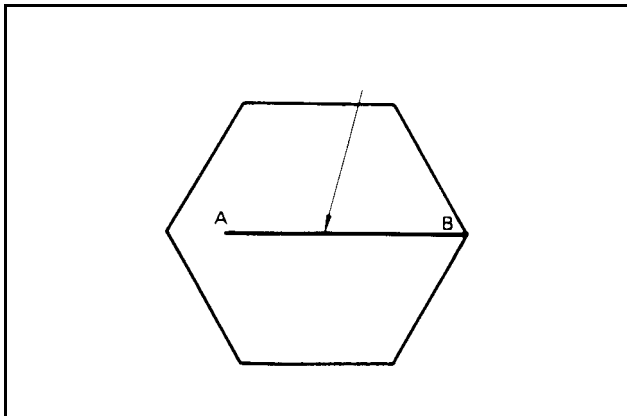

4. Draw a line (A-B) across the center of each bolt.

1-12 GENERAL INFORMATION

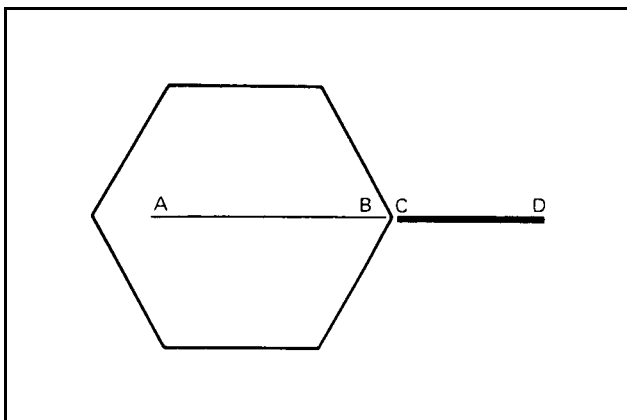

5. Draw another line (C-D) on the face of each of the parts to be clamped. This line should be an extension of the line (A-B).

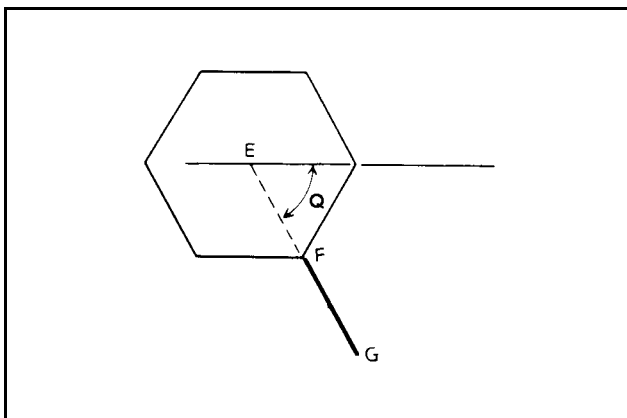

6. Draw another line (F-G) on the face of each of the parts to be clamped. This line will be in the direction of the specified angle (Q) across the center (E) of the nut or bolt.

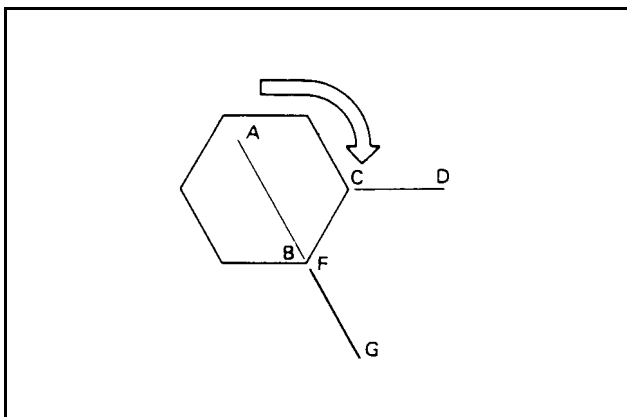

7. Use a socket wrench to tighten each nut or bolt to the point where the line (A-B) is aligned with the line (F-G).

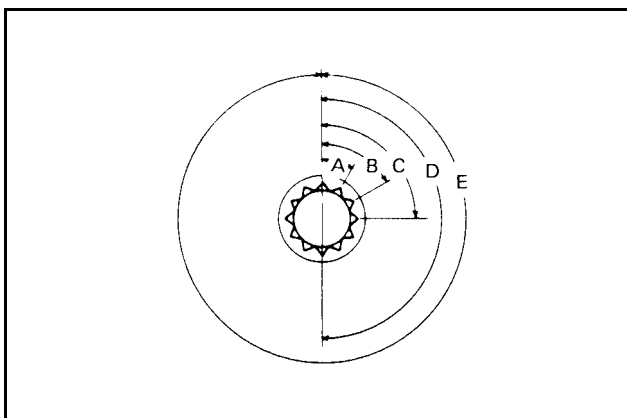

Example: Specified Angle and tightening Rotation

A	30°	1/12 of a turn
B	60°	1/6 of a turn
C	90°	1/4 of a turn
D	180°	1/2 of a turn
E	360°	One full turn



MAJOR COMPONENT MOUNTING NUTS AND BOLTS

CYLINDER HEAD AND COVER

Nm (kgf.m/lb.ft)

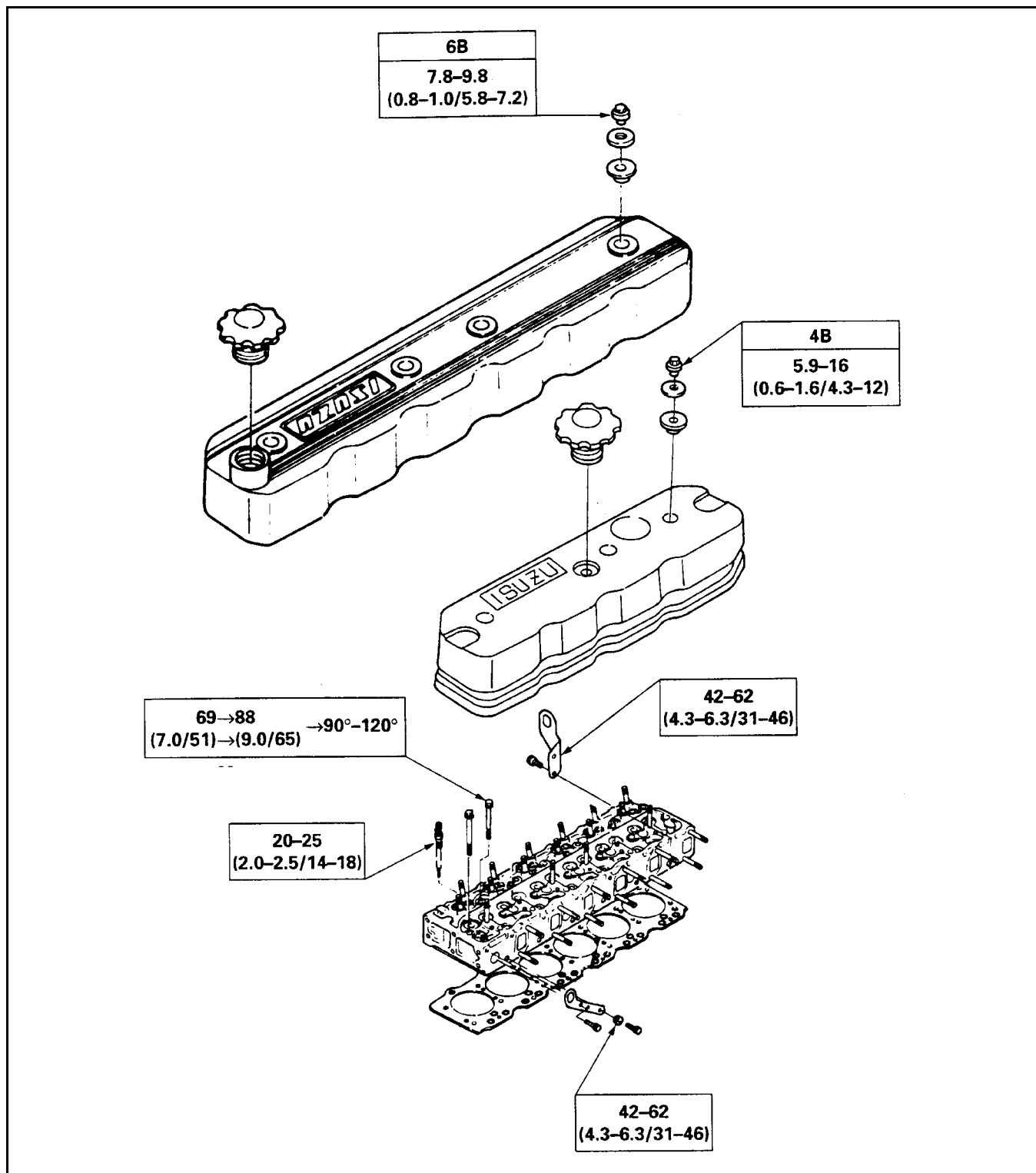

- (1) Apply MoS2 grease (Molybdenum disulfide paste)
- (2) Glow plug

CYLINDER BLOCK

Nm (kgf.m/lb.ft)

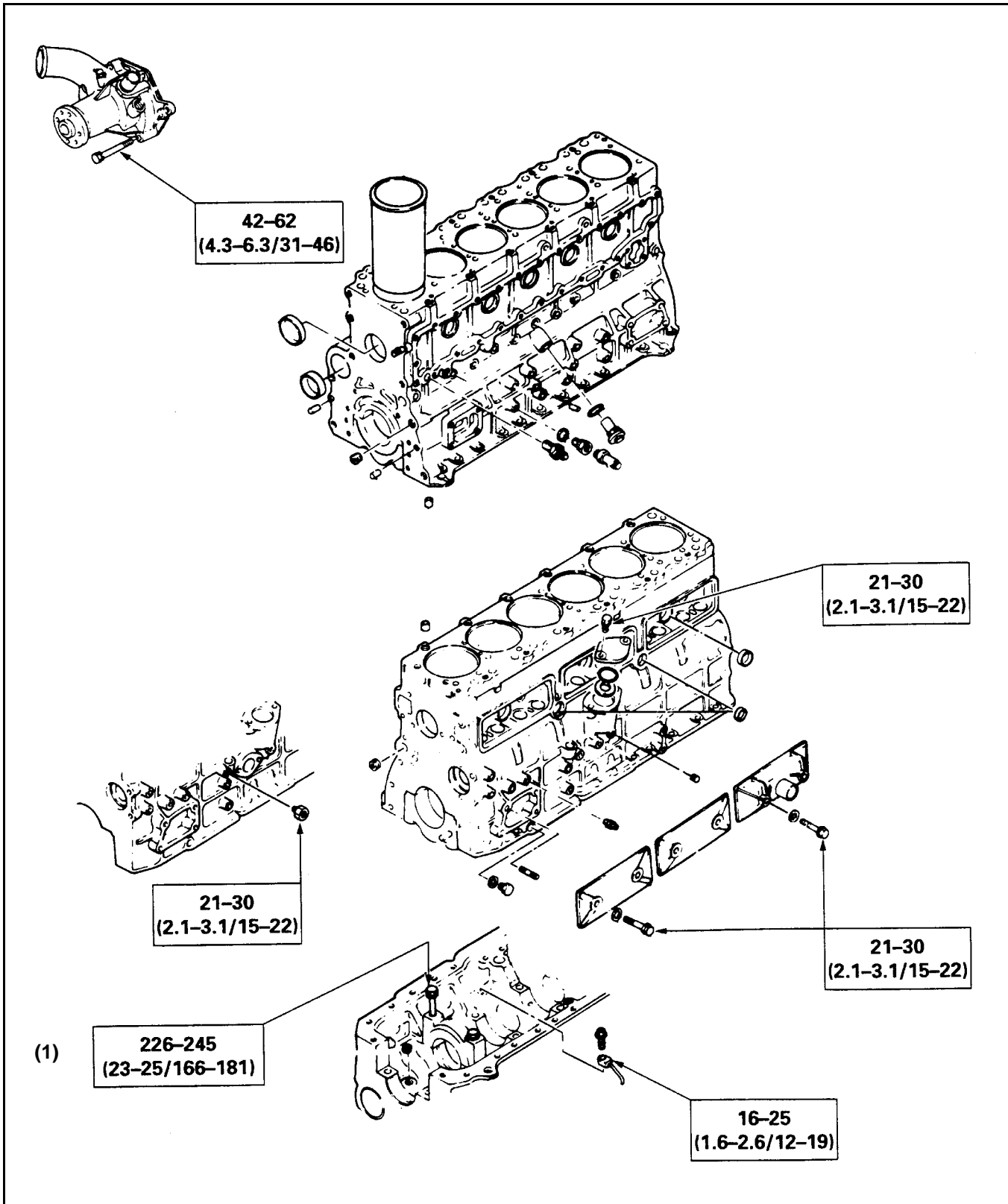

(1) Apply engine oil

OIL PAN AND DIPSTICK

Nm (kgf.m/lb.ft)

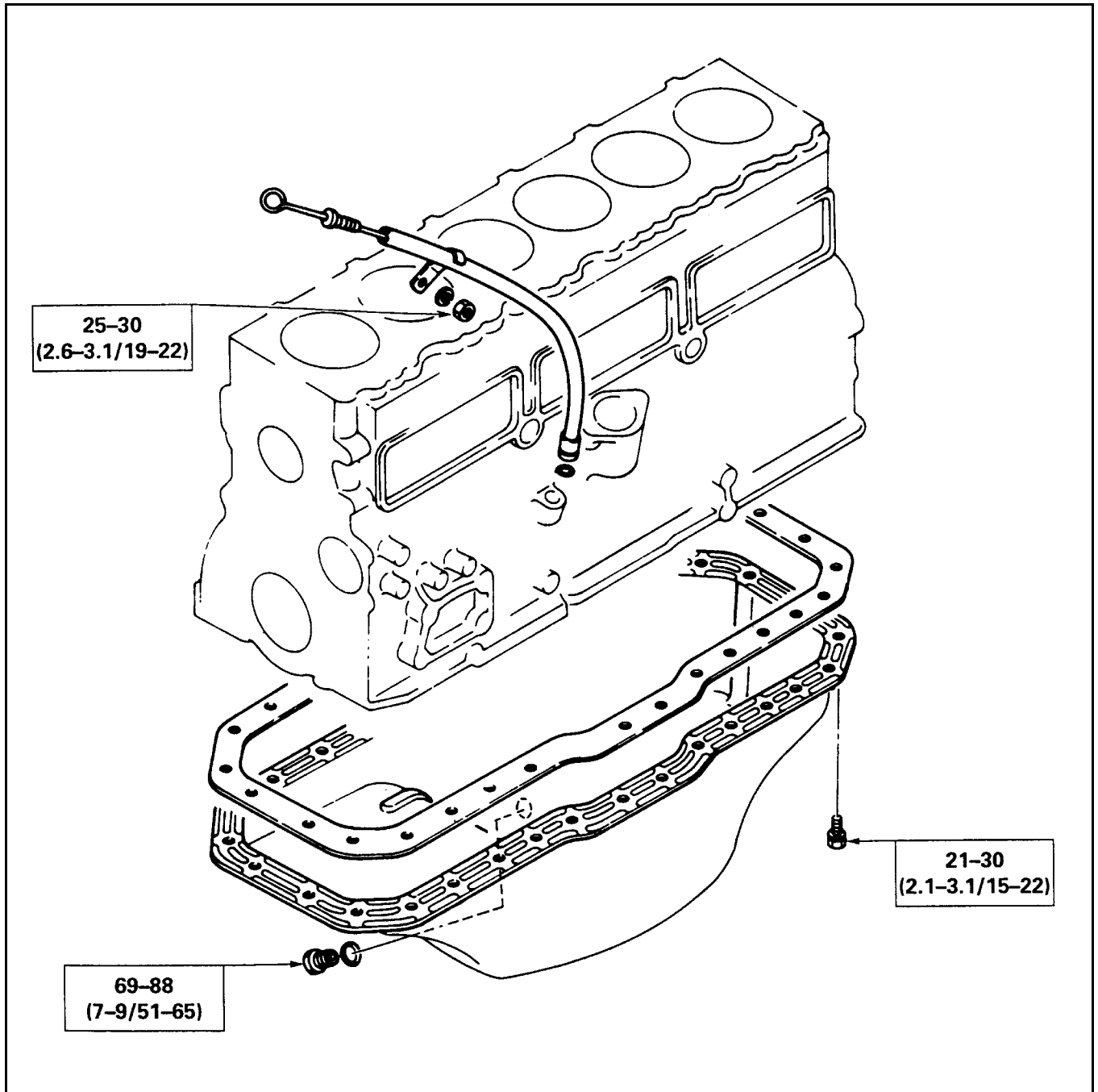

CAMSHAFT AND ROCKER ARM - KG.M (LB.FT)

Nm (kgf.m/lb.ft)

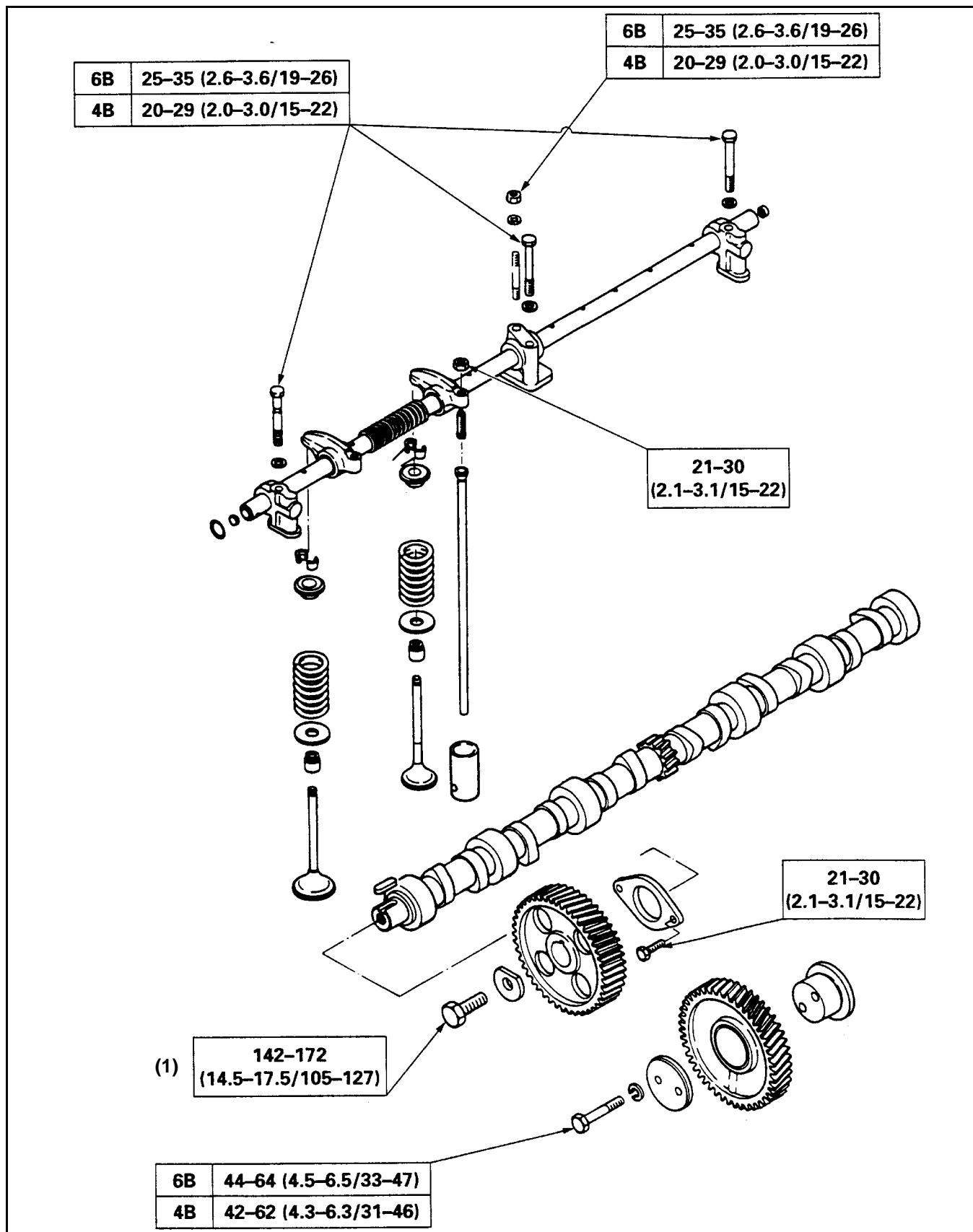

(1) Lubricate with engine oil

CRANKSHAFT, PISTON, AND FLYWHEEL

Nm (kgf.m/lb.ft)

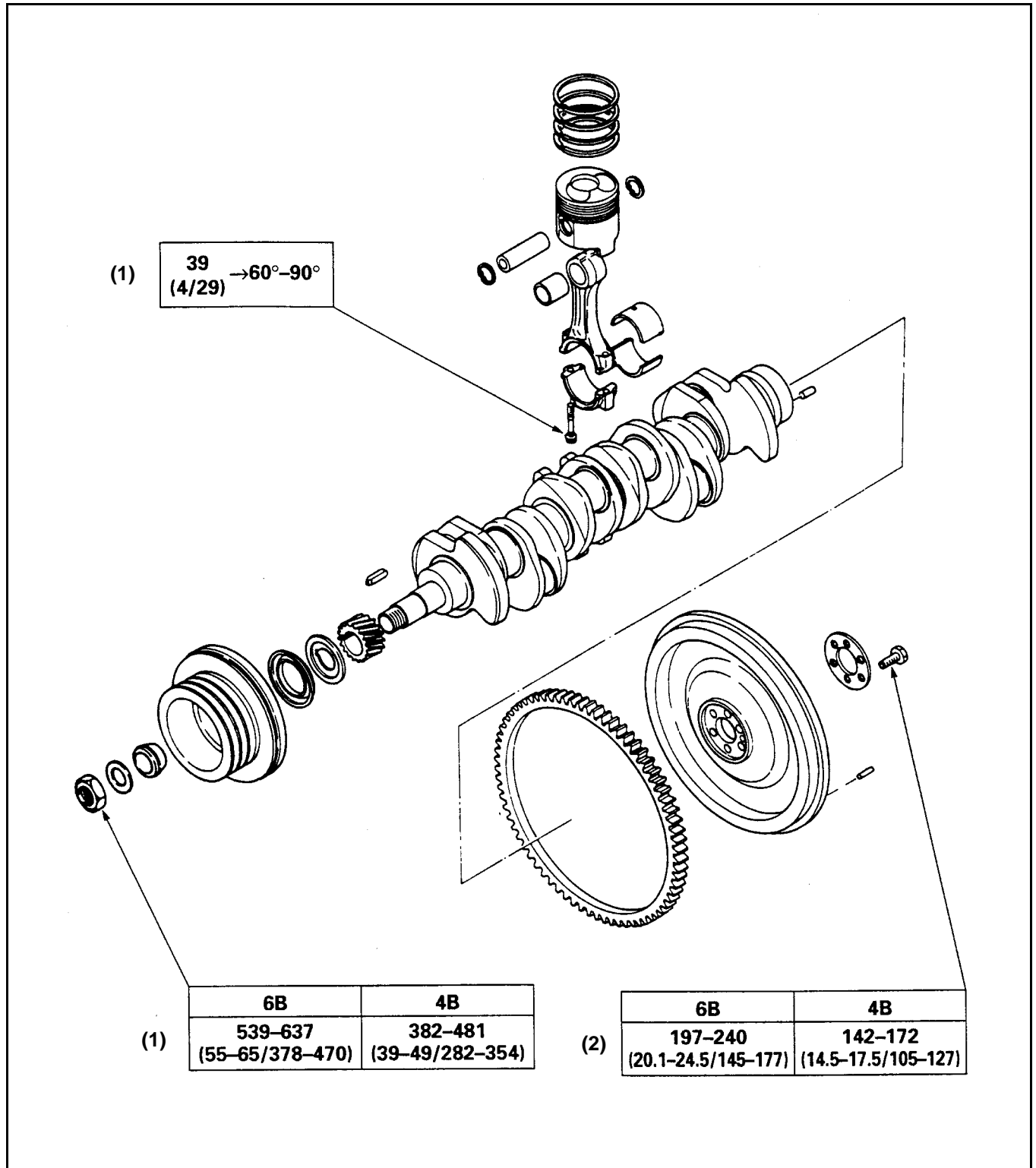

(1) Apply MoS2 grease

(2) Apply engine oil

THERMOSTAT AND THERMOSTAT HOUSING

Nm (kgf.m/lb.ft)

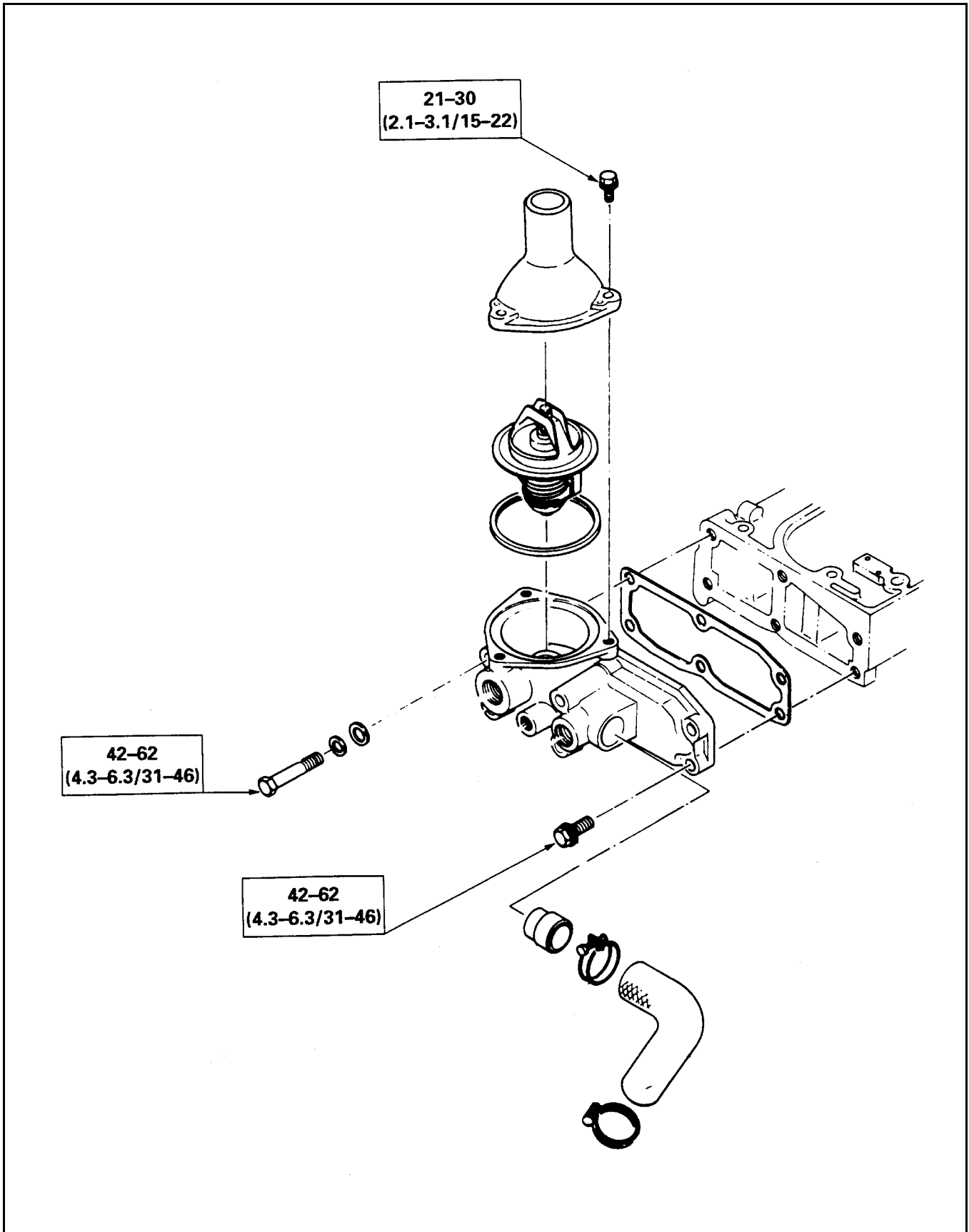

INTAKE AND EXHAUST MANIFOLD

Nm (kgf.m/lb.ft)

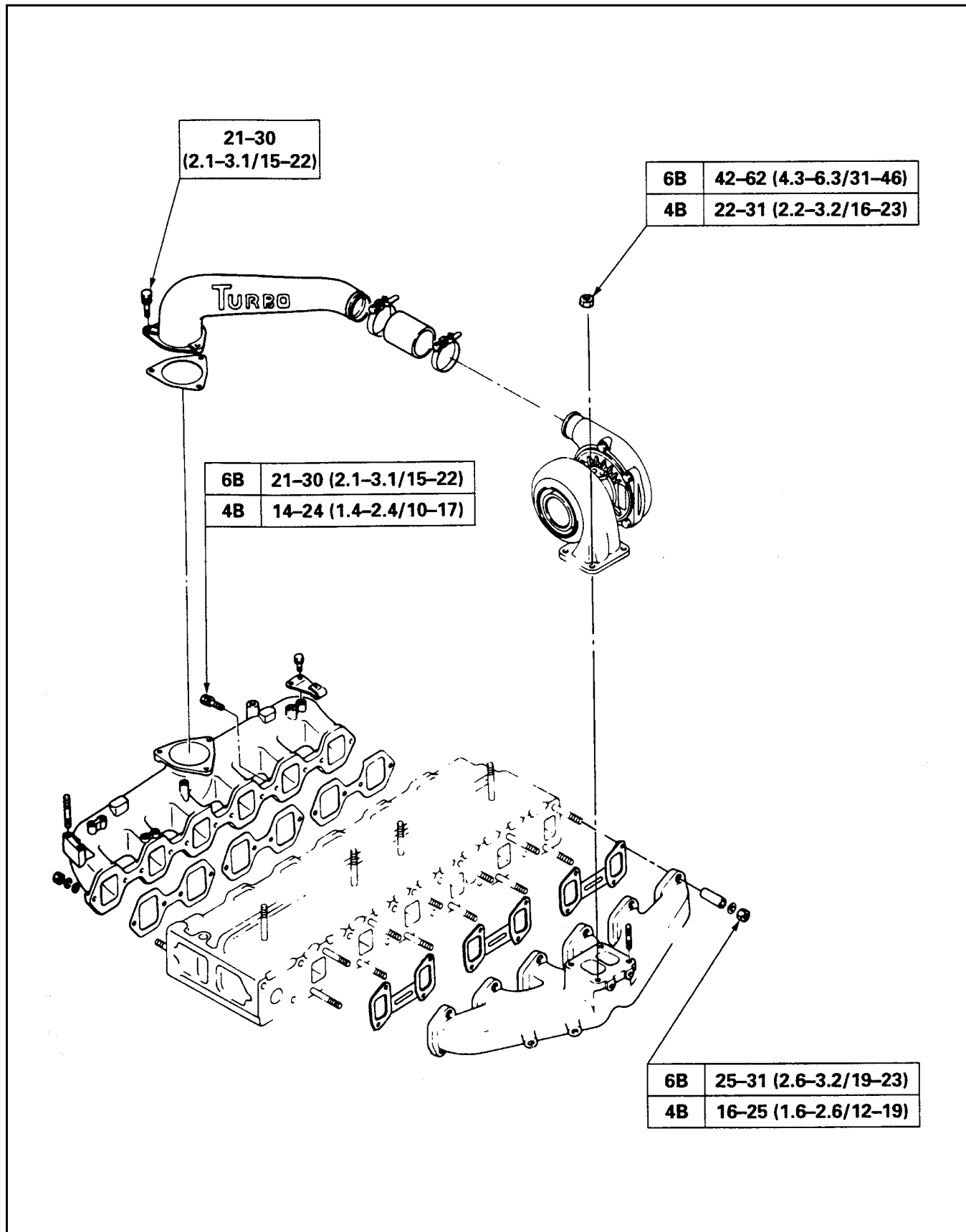

TIMING GEAR CASE AND FLYWHEEL HOUSING

Nm (kgf.m/lb.ft)

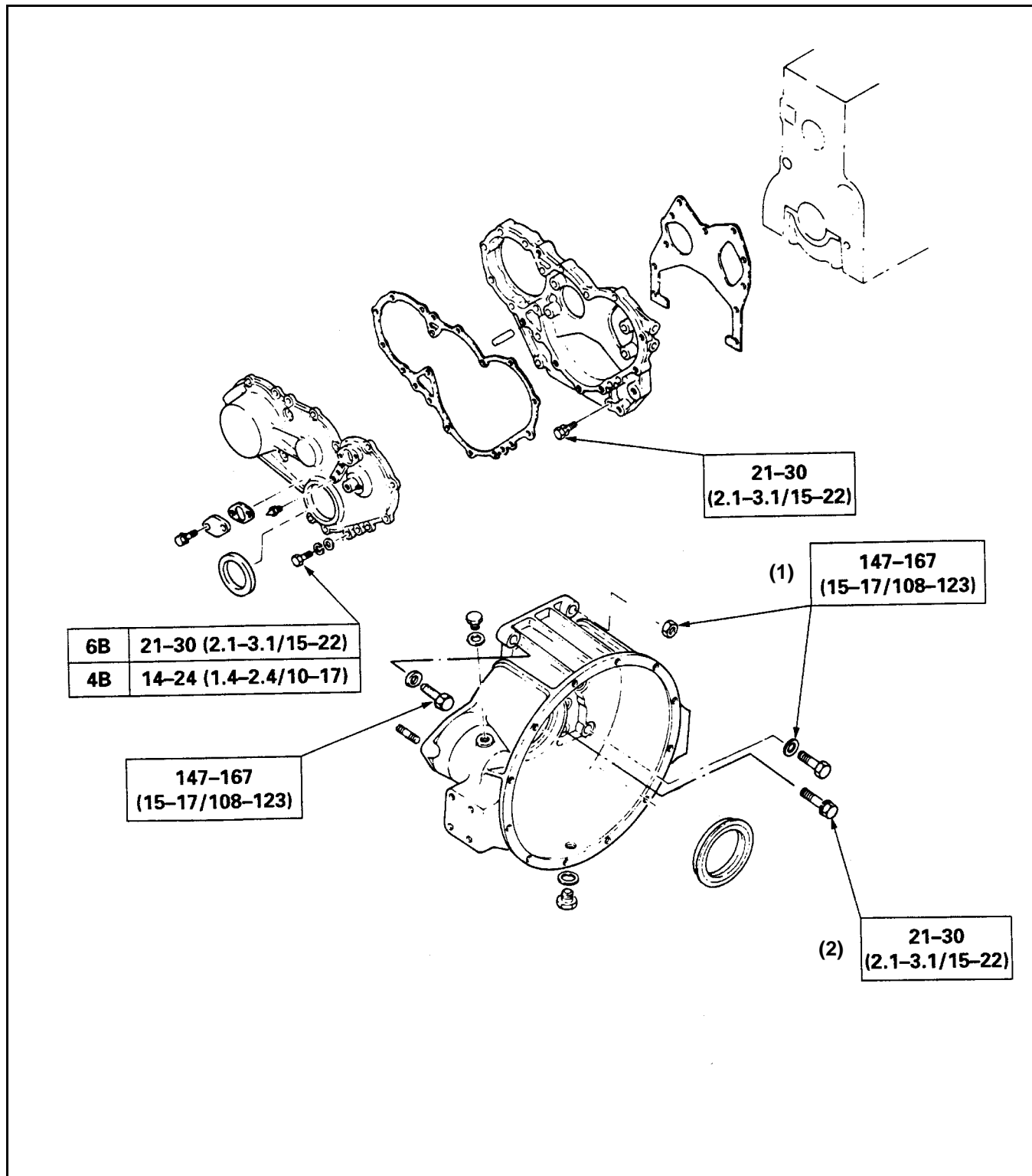

(1) Outer side

(2) Inner side

OIL COOLER, OIL FILTER, AND OIL PUMP

Nm (kgf.m/lb.ft)

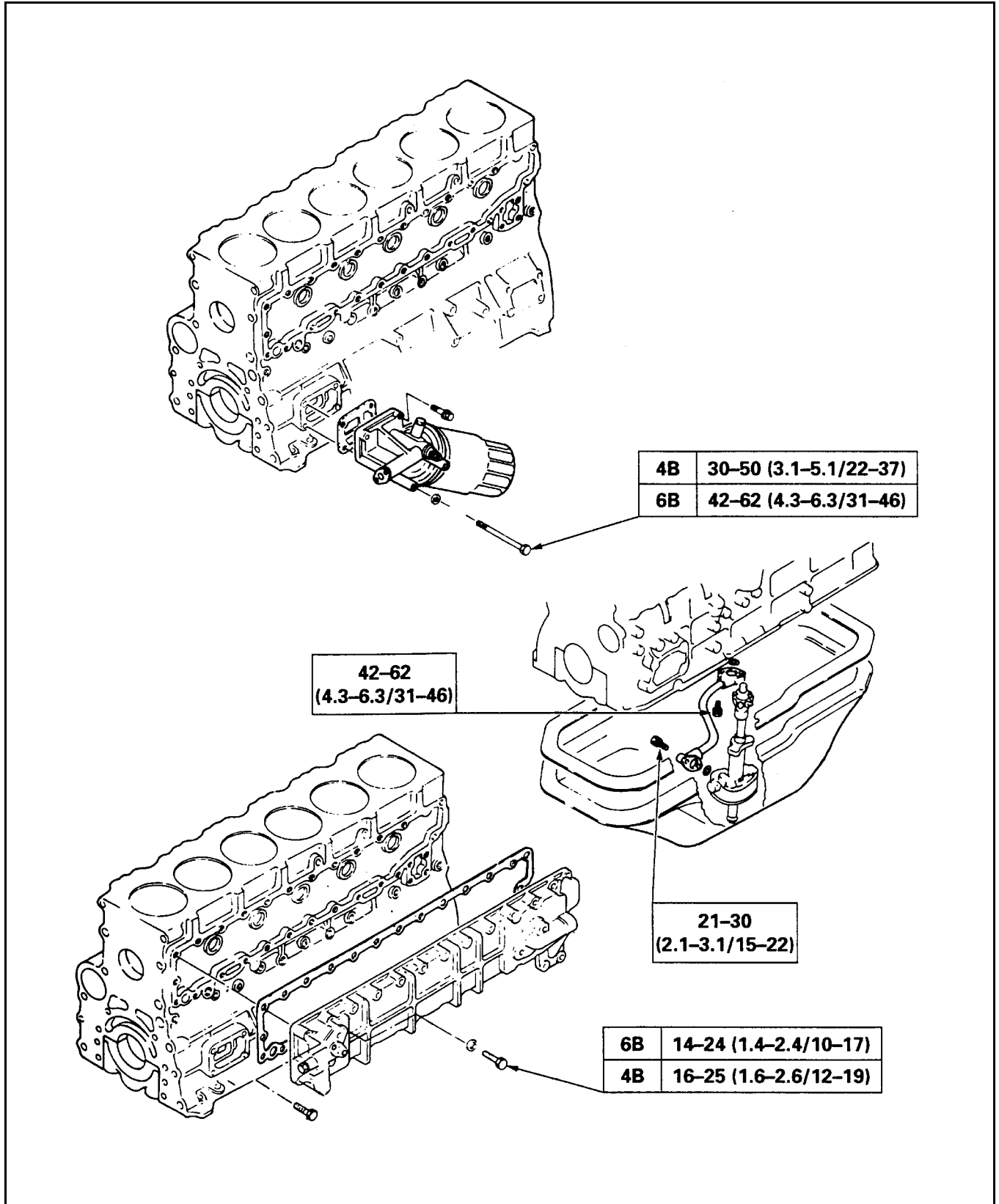

FUEL SYSTEM

Nm (kgf.m/lb.ft)

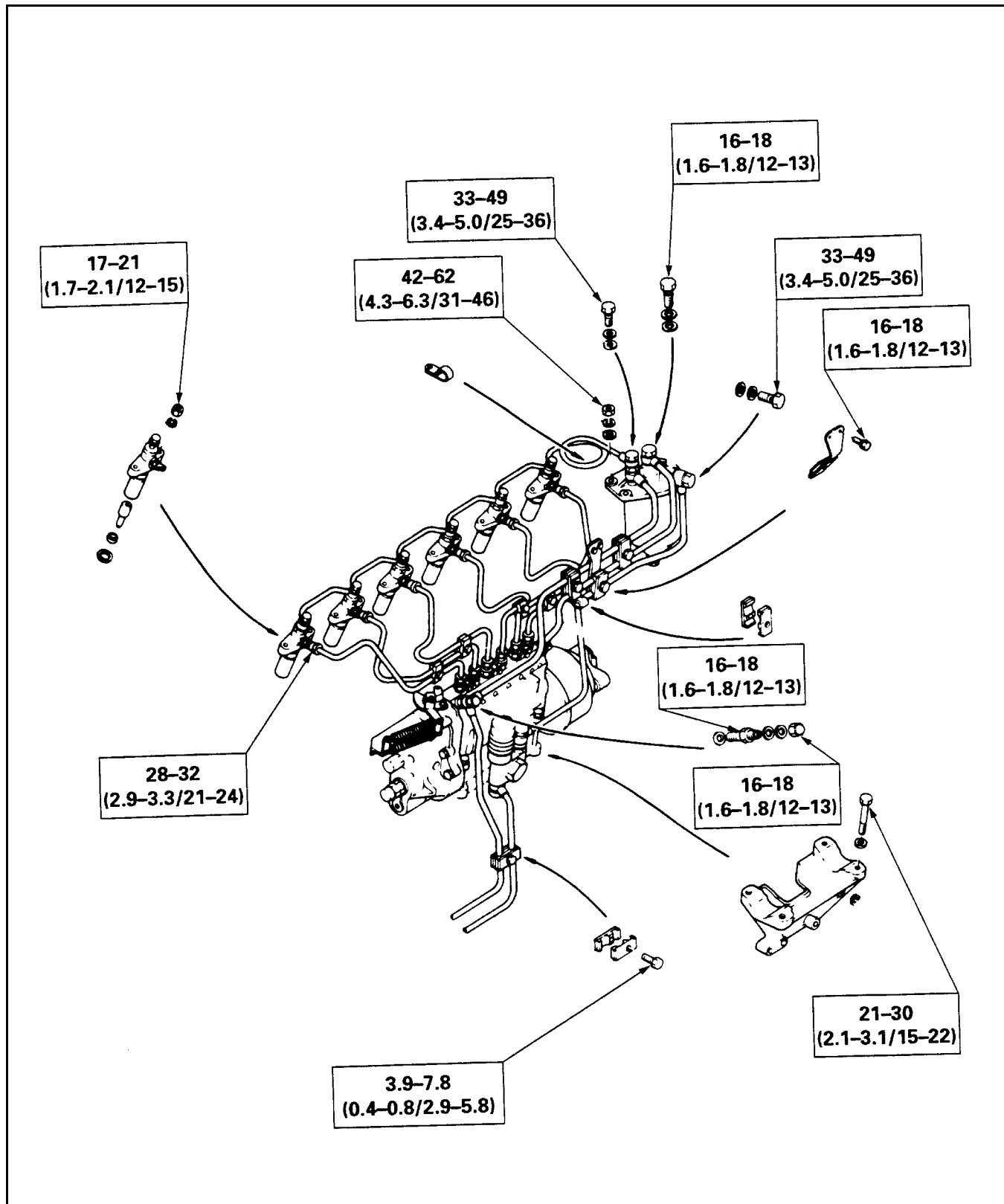

TURBOCHARGER

Nm (kgf.m/lb.ft)

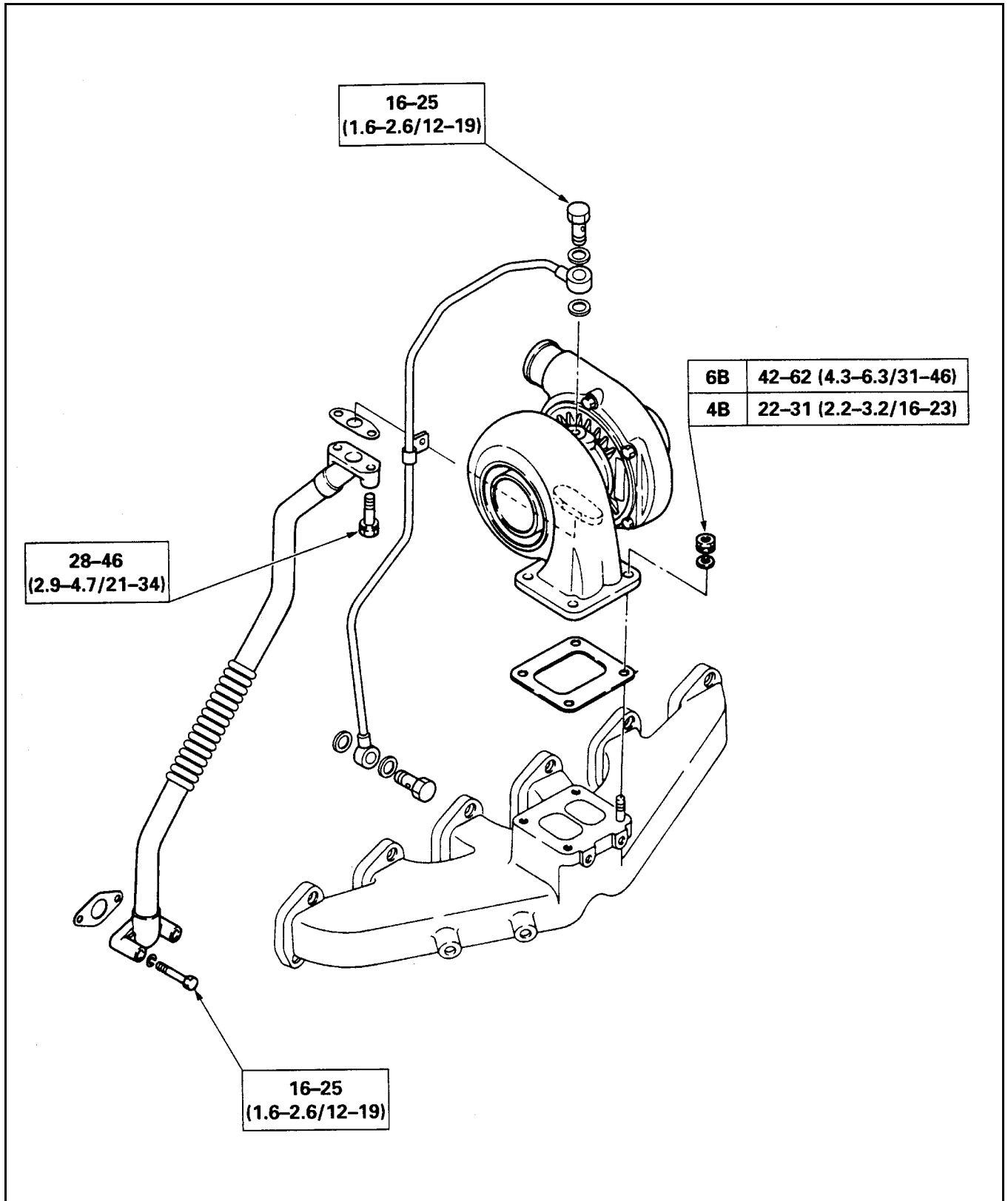

IDENTIFICATION

MODEL IDENTIFICATION

Engine Serial Number

The engine number is stamped on the front left-hand side of the cylinder body.

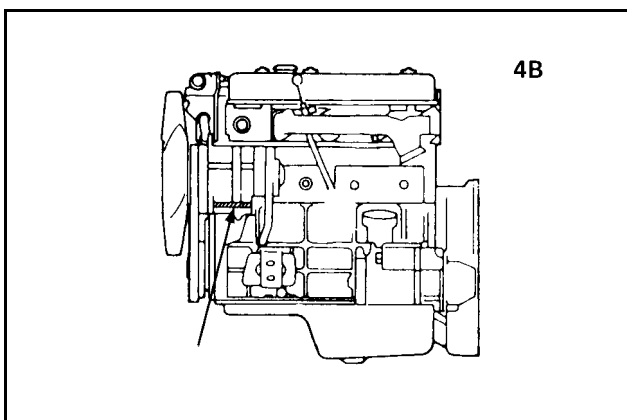
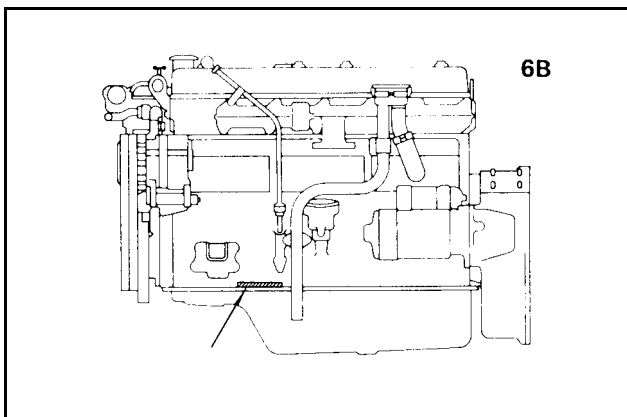

INJECTION PUMP IDENTIFICATION

Injection Pump Number

Injection volume should be adjusted after referring to the adjustment data applicable to the injection pump installed.

The injection pump identification number (A) is stamped on the injection pump identification plate.

Note:

Always check the identification number before beginning a service operation.

Applicable service data will vary according to the identification number. Use of the wrong service data will result in reduced engine performance and engine damage.

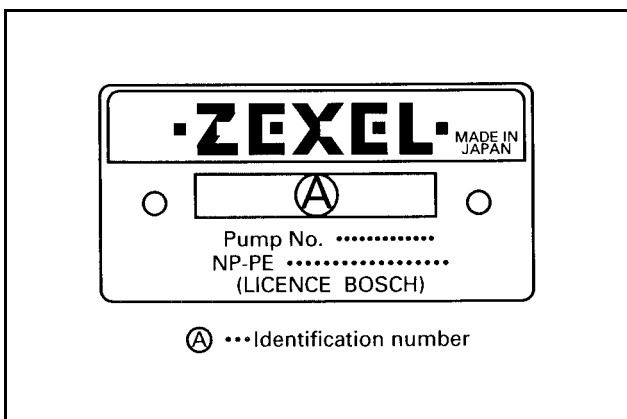

SECTION 2

MAINTENANCE

TABLE OF CONTENTS

ITEM	PAGE
Fuel system	2-2
Cooling system	2-4
Valve clearance adjustment.....	2-4
Injection timing.....	2-6
Compression pressure measurement	2-14
Turbocharger inspection	2-15
Engine repair kit.....	2-17

Note: Maintenance intervals such as fuel or oil filter changes should be referred to in the Operator's Manual.

FUEL SYSTEM

Injection Nozzle

Inspection procedure

1. Clamp the injection nozzle holder in a vise.
2. Use a wrench to remove the injection nozzle holder cap.
3. Remove the injection nozzle holder from the vise.

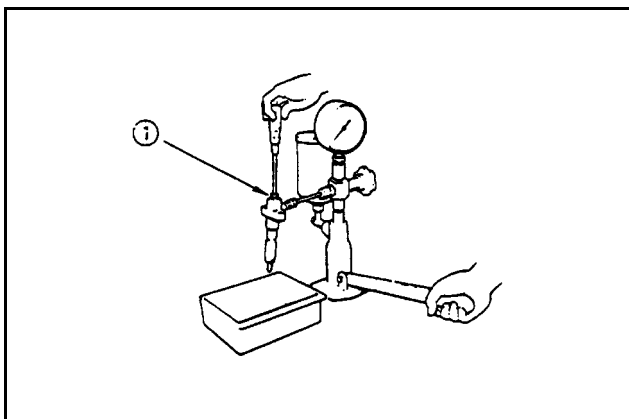
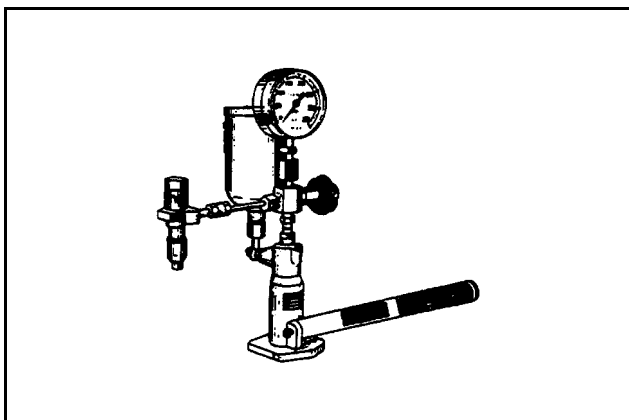
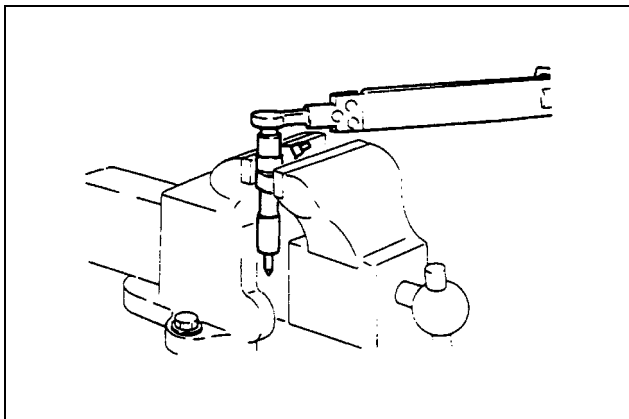

Adjusting Procedure

Injection Starting Pressure Check

1. Attach the injection nozzle holder to the injection nozzle tester.
2. Loosen the adjusting screw (1).
3. Check the injection nozzle starting pressure and the spray condition by operating the injection nozzle tester.
4. Adjust the injection nozzle starting pressure.
Turn the adjusting screw clockwise while operating the injection nozzle tester handle.



Injection starting pressure:

18.1 Mpa (185 kg/cm²/2630 psi)