

# **CX30C** Mini Excavator

# SERVICE MANUAL

**Part number 48175013**

English

October 2017

**CASE**  
CONSTRUCTION

Product: 2017 Case CX30C Mini Excavator Service Manual 48175013  
Full Download: <https://www.arepairmanual.com/downloads/2017-case-cx30c-mini-excavator-service-manual-48175013/>

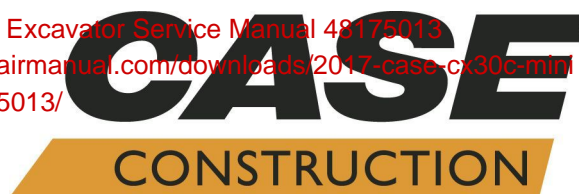

## **SERVICE MANUAL**

**CX30C Cab - TIER 4 final engine**  
**CX30C Canopy - TIER 4 final engine**

Sample manual. Download All pages at:

<https://www.arepairmanual.com/downloads/2017-case-cx30c-mini-excavator-service-manual-48175013/>

48175013 02/10/2017

# Contents

---

## INTRODUCTION

Engine.....	10
[10.001] Engine and crankcase .....	10.1
[10.102] Pan and covers .....	10.2
[10.106] Valve drive and gears .....	10.3
[10.101] Cylinder heads .....	10.4
[10.105] Connecting rods and pistons.....	10.5
[10.103] Crankshaft and flywheel.....	10.6
[10.216] Fuel tanks .....	10.7
[10.206] Fuel filters .....	10.8
[10.220] Throttle linkage.....	10.9
[10.218] Fuel injection system.....	10.10
[10.202] Air cleaners and lines .....	10.11
[10.254] Intake and exhaust manifolds and muffler .....	10.12
[10.400] Engine cooling system .....	10.13
[10.414] Fan and drive .....	10.14
[10.304] Engine lubrication system.....	10.15
Hydraulic systems.....	35
[35.000] Hydraulic systems.....	35.1
[35.300] Reservoir, cooler, and filters.....	35.2
[35.106] Variable displacement pump .....	35.3
[35.359] Main control valve.....	35.4
[35.357] Pilot system .....	35.5
[35.355] Hydraulic hand control .....	35.6
[35.356] Hydraulic foot control.....	35.7
[35.352] Hydraulic swing system .....	35.8
[35.353] Hydraulic travel system .....	35.9

[35.354] Hydraulic central joint .....	35.10
[35.736] Boom hydraulic system .....	35.11
[35.737] Dipper hydraulic system.....	35.12
[35.738] Excavator and backhoe bucket hydraulic system.....	35.13
[35.734] Tool quick coupler hydraulic system .....	35.14
[35.360] Hammer and rotating bucket hydraulic system .....	35.15
[35.739] Swing arm hydraulic system .....	35.16
[35.741] Dozer blade cylinders .....	35.17
<b>Frames and ballasting .....</b>	<b>39</b>
[39.103] Swing ring assembly .....	39.1
[39.140] Ballasts and supports .....	39.2
<b>Tracks and track suspension.....</b>	<b>48</b>
[48.130] Track frame and driving wheels.....	48.1
[48.100] Tracks .....	48.2
[48.134] Track tension units .....	48.3
[48.138] Track rollers .....	48.4
<b>Electrical systems .....</b>	<b>55</b>
[55.000] Electrical system .....	55.1
[55.100] Harnesses and connectors.....	55.2
[55.525] Cab engine controls.....	55.3
[55.201] Engine starting system .....	55.4
[55.301] Alternator.....	55.5
[55.302] Battery.....	55.6
[55.202] Cold start aid .....	55.7
[55.011] Fuel tank system .....	55.8
[55.014] Engine intake and exhaust system.....	55.9
[55.012] Engine cooling system .....	55.10
[55.013] Engine oil system .....	55.11

[55.512] Cab controls.....	55.12
[55.524] Cab controls (Lift arm, Boom, Dipper, Bucket).....	55.13
[55.518] Wiper and washer system.....	55.14
[55.404] External lighting .....	55.15
[55.405] External lighting switches and relays .....	55.16
[55.514] Cab lighting .....	55.17
[55.408] Warning indicators, alarms, and instruments .....	55.18
<b>Booms, dippers, and buckets .....</b>	<b>84</b>
[84.114] Boom pivoting support .....	84.1
[84.910] Boom.....	84.2
[84.912] Dipper arm .....	84.3
[84.100] Bucket.....	84.4
<b>Dozer blade and arm.....</b>	<b>86</b>
[86.110] Dozer blade .....	86.1
<b>Platform, cab, bodywork, and decals .....</b>	<b>90</b>
[90.150] Cab.....	90.1
[90.160] Cab interior trim and panels.....	90.2
[90.118] Protections and footboards.....	90.3
[90.120] Mechanically-adjusted operator seat.....	90.4
[90.100] Engine hood and panels .....	90.5
[90.105] Machine shields and guards .....	90.6



## **INTRODUCTION**

# Contents

---

## INTRODUCTION

Foreword - Important notice regarding equipment servicing .....	3
Safety rules .....	4
Safety rules - General information .....	5
Safety rules - Personal safety .....	6
Safety rules - Ecology and the environment .....	9
Torque - Standard torque settings .....	10
Torque - Special torque settings .....	12
Basic instructions - Shop and assembly .....	17
Machine specifications .....	19
Weights .....	21
Dimensions .....	22
Conversion factors .....	25
Hydraulic contamination .....	37
General specification .....	38
Consumables .....	40
Consumables - Engine oil recommended operating temperature range .....	44
Product identification .....	45
Product identification - Machine orientation .....	48

---

## **Foreword - Important notice regarding equipment servicing**

All repair and maintenance work listed in this manual must be carried out only by qualified dealership personnel, strictly complying with the instructions given, and using, whenever possible, the special tools.

Anyone who performs repair and maintenance operations without complying with the procedures provided herein shall be responsible for any subsequent damages.

The manufacturer and all the organizations of its distribution chain, including - without limitation - national, regional, or local dealers, reject any responsibility for damages caused by parts and/or components not approved by the manufacturer, including those used for the servicing or repair of the product manufactured or marketed by the manufacturer. In any case, no warranty is given or attributed on the product manufactured or marketed by the manufacturer in case of damages caused by parts and/or components not approved by the manufacturer.

The manufacturer reserves the right to make improvements in design and changes in specifications at any time without notice and without incurring any obligation to install them on units previously sold. Specifications, descriptions, and illustrative material herein are as accurate as known at time of publication but are subject to change without notice.

In case of questions, refer to your CASE CONSTRUCTION Sales and Service Networks.

## Safety rules

### Personal safety



This is the safety alert symbol. It is used to alert you to potential personal injury hazards. Obey all safety messages that follow this symbol to avoid possible death or injury.

Throughout this manual you will find the signal words DANGER, WARNING, and CAUTION followed by special instructions. These precautions are intended for the personal safety of you and those working with you.

Read and understand all the safety messages in this manual before you operate or service the machine.

 DANGER indicates a hazardous situation that, if not avoided, will result in death or serious injury.

 WARNING indicates a hazardous situation that, if not avoided, could result in death or serious injury.

 CAUTION indicates a hazardous situation that, if not avoided, could result in minor or moderate injury.

**FAILURE TO FOLLOW DANGER, WARNING, AND CAUTION MESSAGES COULD RESULT IN DEATH OR SERIOUS INJURY.**

### Machine safety

**NOTICE:** Notice indicates a situation that, if not avoided, could result in machine or property damage.

Throughout this manual you will find the signal word Notice followed by special instructions to prevent machine or property damage. The word Notice is used to address practices not related to personal safety.

### Information

**NOTE:** Note indicates additional information that clarifies steps, procedures, or other information in this manual.

Throughout this manual you will find the word Note followed by additional information about a step, procedure, or other information in the manual. The word Note is not intended to address personal safety or property damage.

## **Safety rules - General information**

### **Cleaning**

Clean the metal parts with cleaning solution that meets the standard and steam cleaning. (except for bearings)

After cleaning, dry well, and inject oil in all parts.

Also inject oil into the bearings after drying.

### **Inspection**

When disassembling parts, check all the parts.

If there are any worn or damaged parts, replace them.

Inspect carefully to prevent initial breakdowns.

### **Bearing**

Replace any loose bearings.

Air dry bearings before installing them.

### **Needle bearing**

When inserting needle bearings, be very careful not to damage them.

Apply grease to the section where the needle bearing will be inserted.

### **Gear**

Check that there is no wear and no damage.

### **Oil seal, O-ring, gasket**

Always install new oil seals, O-rings, and gaskets.

Apply grease to sections where oil seals and O-rings will be inserted.

### **Shaft**

Check that there is no wear and no damage.

Check the bearings and check for damaged oil seals on the shaft.

### **Service parts**

Install CASE CONSTRUCTION genuine service parts.

When placing an order, check the parts catalog. It contains the CASE CONSTRUCTION genuine part numbers.

Any breakdowns arising from the installation of non-genuine parts are not covered by the warranty.

### **Lubricants (fuel, hydraulic oil)**

Use the oil from the specified company or specified in the operator's manual or service Manual.

Any breakdowns arising from any fuel or hydraulic oil other than those specified are not covered by the warranty.

## Safety rules - Personal safety

### Preliminary warnings to maintenance operation

#### **⚠ WARNING**

**Avoid injury!**

Shut off the engine, remove the key, and make sure all machine motion stops before you service the machine.

Failure to comply could result in death or serious injury.

W1128B

#### **⚠ WARNING**

**Improper operation or service of this machine can result in an accident.**

Assign a supervisor to direct worksite operations. Agree on all safety measures, procedures, and suitable hand signals.

Failure to comply could result in death or serious injury.

W0287A

#### **⚠ CAUTION**

**Pinch hazard!**

Always use suitable tools to align mating parts. **DO NOT** use your hand or fingers.

Failure to comply could result in minor or moderate injury.

C0044A

### Personal Protective Equipment (PPE)

#### **⚠ WARNING**

**Avoid injury!**

Use Personal Protective Equipment (PPE), including protective goggles, gloves, and safety footwear.

Failure to comply could result in death or serious injury.

W1036A

### Lifting operation

#### **⚠ WARNING**

**Crushing hazard!**

The lifting systems must be operated by qualified personnel who are aware of the correct procedures to follow. Make sure all lifting equipment is in good condition, and all hooks are equipped with safety latches.

Failure to comply could result in death or serious injury.

W0256A

#### **⚠ WARNING**

**Heavy objects!**

Lift and handle all heavy components using lifting equipment with adequate capacity. Always support units or parts with suitable slings or hooks. Make sure the work area is clear of all bystanders.

Failure to comply could result in death or serious injury.

W0398A

#### **⚠ WARNING**

**Improper operation or service of this machine can result in an accident.**

Raised equipment or machine movement without an operator can cause serious injury. Always do the following before performing any maintenance:

Park the machine on flat, level ground.

Lower the attachment to the ground.

Shut down the engine and remove the ignition key.

Lock the tracks.

Failure to comply could result in death or serious injury.

W0944D

**⚠ WARNING**

Tip-over hazard!  
Only raise the track as little as necessary.  
Failure to comply could result in death or serious injury.

W0276A

**Hydraulic system**

**⚠ WARNING**

Burn hazard!  
Before performing any service on the hydraulic system, you must allow it to cool. Hydraulic fluid temperature should not exceed 40 °C (104 °F).  
Failure to comply could result in death or serious injury.

W0241A

**⚠ WARNING**

Pressurized fluid can penetrate the skin and cause severe injuries.  
The grease in the cylinder is under high pressure. Never loosen the grease fitting adaptor completely in order to speed up the flow of grease.  
Failure to comply could result in death or serious injury.

W0261A

**⚠ WARNING**

Pressurized system!  
Before attempting any service procedure, it is your responsibility to know the number of accumulators on the machine, and the correct procedure for releasing the pressure of each accumulator.  
Failure to comply could result in death or serious injury.

W0136A

**Battery**

**⚠ WARNING**

Battery acid causes burns. Batteries contain sulfuric acid.  
Avoid contact with skin, eyes or clothing. Antidote (external): Flush with water. Antidote (eyes): flush with water for 15 minutes and seek medical attention immediately. Antidote (internal): Drink large quantities of water or milk. Do not induce vomiting. Seek medical attention immediately.  
Failure to comply could result in death or serious injury.

W0111A

**⚠ WARNING**

Battery gas can explode!  
To prevent an explosion: 1. Always disconnect the negative (-) battery cable first. 2. Always connect the negative (-) battery cable last. 3. Do not short circuit the battery posts with metal objects. 4. Do not weld, grind, or smoke near a battery.  
Failure to comply could result in death or serious injury.

W0011A

**Fluids**

**⚠ WARNING**

Hazardous chemicals!  
Coolant can be toxic. Avoid contact with skin, eyes, and clothing. Antidotes:  
EXTERNAL - Rinse thoroughly with water. Remove soiled clothing.  
INTERNAL - Rinse the mouth with water. DO NOT induce vomiting. Seek immediate medical attention.  
EYES - Flush with water. Seek immediate medical attention.  
Failure to comply could result in death or serious injury.

W0282A

**⚠ WARNING**

**Burn hazard!**

Hot coolant can spray and scald if you remove the radiator or deaeration tank cap while the system is hot. To remove the cap: allow the system to cool, turn the cap to the first notch, and wait for all pressure to release. Remove the cap only after all pressure has released.

Failure to comply could result in death or serious injury.

W0367A

**⚠ WARNING**

**Escaping fluid!**

Hydraulic fluid or diesel fuel leaking under pressure can penetrate the skin and cause infection or other injury. To prevent personal injury: Relieve all pressure before disconnecting fluid lines or performing work on the hydraulic system. Before applying pressure, make sure all connections are tight and all components are in good condition. Never use your hand to check for suspected leaks under pressure. Use a piece of cardboard or wood for this purpose. If injured by leaking fluid, see your doctor immediately.

Failure to comply could result in death or serious injury.

W0178A

**⚠ WARNING**

**Chemical hazard!**

When handling fuel, lubricants, and other service chemicals, follow the manufacturer's instructions. Wear Personal Protective Equipment (PPE) as instructed. Do not smoke or use open flame. Collect fluids in proper containers. Obey all local and environmental regulations when disposing of chemicals.

Failure to comply could result in death or serious injury.

W0371A

---

## Safety rules - Ecology and the environment

Soil, air, and water quality is important for all industries and life in general. When legislation does not yet rule the treatment of some of the substances that advanced technology requires, sound judgment should govern the use and disposal of products of a chemical and petrochemical nature.

Familiarize yourself with the relative legislation applicable to your country, and make sure that you understand this legislation. Where no legislation exists, obtain information from suppliers of oils, filters, batteries, fuels, anti-freeze, cleaning agents, etc., with regard to the effect of these substances on man and nature and how to safely store, use, and dispose of these substances.

### Helpful hints

- Avoid the use of cans or other inappropriate pressurized fuel delivery systems to fill tanks. Such delivery systems may cause considerable spillage.
- In general, avoid skin contact with all fuels, oils, acids, solvents, etc. Most of these products contain substances that may be harmful to your health.
- Modern oils contain additives. Do not burn contaminated fuels and or waste oils in ordinary heating systems.
- Avoid spillage when you drain fluids such as used engine coolant mixtures, engine oil, hydraulic fluid, brake fluid, etc. Do not mix drained brake fluids or fuels with lubricants. Store all drained fluids safely until you can dispose of the fluids in a proper way that complies with all local legislation and available resources.
- Do not allow coolant mixtures to get into the soil. Collect and dispose of coolant mixtures properly.
- The air-conditioning system contains gases that should not be released into the atmosphere. Consult an air-conditioning specialist or use a special extractor to recharge the system properly.
- Repair any leaks or defects in the engine cooling system or hydraulic system immediately.
- Do not increase the pressure in a pressurized circuit as this may lead to a component failure.
- Protect hoses during welding. Penetrating weld splatter may burn a hole or weaken hoses, allowing the loss of oils, coolant, etc.

### Battery recycling

Batteries and electric accumulators contain several substances that can have a harmful effect on the environment if the batteries are not properly recycled after use. Improper disposal of batteries can contaminate the soil, groundwater, and waterways. CASE CONSTRUCTION strongly recommends that you return all used batteries to a CASE CONSTRUCTION dealer, who will dispose of the used batteries or recycle the used batteries properly. In some countries, this is a legal requirement.



### Mandatory battery recycling

**NOTE:** The following requirements are mandatory in Brazil.

Batteries are made of lead plates and a sulfuric acid solution. Because batteries contain heavy metals such as lead, CONAMA Resolution 401/2008 requires you to return all used batteries to the battery dealer when you replace any batteries. Do not dispose of batteries in your household garbage.

Points of sale are obliged to:

- Accept the return of your used batteries
- Store the returned batteries in a suitable location
- Send the returned batteries to the battery manufacturer for recycling

## Torque - Standard torque settings

### BOLT AND NUT

Use following table for unspecified torque.

#### Coarse thread

Bolt size	Wrench	8 t	10 t
M6 x 1.0	10 mm	8.34 – 12.26 N·m (6.15 – 9.04 lb ft)	11.12 – 17.08 N·m (8.20 – 12.60 lb ft)
M8 x 1.25	13 mm	19.66 – 29.42 N·m (14.50 – 21.70 lb ft)	26.44 – 40.27 N·m (19.50 – 29.70 lb ft)
M10 x 1.5	17 mm	39.18 – 58.84 N·m (28.90 – 43.40 lb ft)	53.96 – 81.35 N·m (39.80 – 60.00 lb ft)
M12 x 1.75	19 mm	72.54 – 109.82 N·m (53.50 – 81.00 lb ft)	96.13 – 154.56 N·m (70.90 – 114.00 lb ft)
M14 x 2.0	22 mm	119.58 – 162.70 N·m (88.20 – 120.00 lb ft)	164.05 – 221.00 N·m (121.00 – 163.00 lb ft)
M16 x 2.0	24 mm	183.04 – 246.76 N·m (135.00 – 182.00 lb ft)	246.76 – 334.89 N·m (182.00 – 247.00 lb ft)
M18 x 2.5	27 mm	253.54 – 343.02 N·m (187.00 – 253.00 lb ft)	344.38 – 466.40 N·m (254.00 – 344.00 lb ft)
M20 x 2.5	30 mm	355.22 – 479.96 N·m (262.00 – 354.00 lb ft)	482.67 – 653.50 N·m (356.00 – 482.00 lb ft)
M22 x 2.5	32 mm	473.18 – 620.96 N·m (349.00 – 458.00 lb ft)	645.37 – 961.27 N·m (476.00 – 709.00 lb ft)
M24 x 3.0	36 mm	612.83 – 828.40 N·m (452.00 – 611.00 lb ft)	833.83 – 1128.04 N·m (615.00 – 832.00 lb ft)
M30 x 3.0	46 mm	1217.52 – 1645.96 N·m (898.00 – 1214.00 lb ft)	1658.17 – 2245.23 N·m (1223.00 – 1656.00 lb ft)
M36 x 4.0	55 mm	1709.69 – 2310.31 N·m (1261.00 – 1704.00 lb ft)	2451.32 – 3039.74 N·m (1808.00 – 2242.00 lb ft)

#### Fine thread

Bolt size	Wrench	8 t	10 t
M 8 x 1.0	13 mm	21.56 – 33.35 N·m (15.90 – 24.60 lb ft)	29.42 – 43.12 N·m (21.70 – 31.80 lb ft)
M10 x 1.2	17 mm	44.06 – 65.76 N·m (32.50 – 48.50 lb ft)	57.89 – 87.31 N·m (42.70 – 64.40 lb ft)
M12 x 1.25	19 mm	76.47 – 113.75 N·m (56.40 – 83.90 lb ft)	103.99 – 157.27 N·m (76.70 – 116.00 lb ft)
M14 x 1.5	22 mm	130.43 – 177.61 N·m (96.20 – 131.00 lb ft)	176.26 – 235.91 N·m (130.00 – 174.00 lb ft)
M16 x 1.5	24 mm	195.24 – 264.38 N·m (144.00 – 195.00 lb ft)	260.32 – 352.51 N·m (192.00 – 260.00 lb ft)
M18 x 1.5	27 mm	280.65 – 427.08 N·m (207.00 – 315.00 lb ft)	376.92 – 509.79 N·m (278.00 – 376.00 lb ft)
M20 x 1.5	30 mm	391.83 – 530.12 N·m (289.00 – 391.00 lb ft)	523.35 – 707.74 N·m (386.00 – 522.00 lb ft)
M22 x 1.5	32 mm	516.57 – 699.60 N·m (381.00 – 516.00 lb ft)	692.82 – 938.23 N·m (511.00 – 692.00 lb ft)
M24 x 2.0	36 mm	665.71 – 901.62 N·m (491.00 – 665.00 lb ft)	892.13 – 1206.68 N·m (658.00 – 890.00 lb ft)
M30 x 2.0	46 mm	1342.26 – 1815.44 N·m (990.00 – 1339.00 lb ft)	1781.54 – 2435.05 N·m (1314.00 – 1796.00 lb ft)
M36 x 3.0	55 mm	1884.59 – 2548.94 N·m (1390.00 – 1880.00 lb ft)	2567.92 – 3473.61 N·m (1894.00 – 2562.00 lb ft)

#### Pipe and hose (FLARE type)

Thread size (PF)	Wrench	Torque
1/4"	19 mm	39.18 N·m (28.90 lb ft)
3/8"	22 mm	49.08 N·m (36.20 lb ft)
1/2"	27 mm	93.14 N·m (68.70 lb ft)
3/4"	36 mm	176.26 N·m (130.00 lb ft)
1"	41 mm	206.08 N·m (152.00 lb ft)
1-1/4"	50 mm	343.02 N·m (253.00 lb ft)

#### Pipe and hose (ORFS type)

Thread size (UNF)	Wrench	Torque
9/16-18	19 mm	39.18 N·m (28.90 lb ft)
11/16-16	22 mm	49.08 N·m (36.20 lb ft)
13/16-16	27 mm	93.14 N·m (68.70 lb ft)

## INTRODUCTION

Thread size (UNF)	Wrench	Torque
1-3/16-12	36 mm	176.26 N·m (130.00 lb ft)
1-7/16-12	41 mm	206.08 N·m (152.00 lb ft)
1-11/16-12	50 mm	343.02 N·m (253.00 lb ft)

### Fitting

Thread size	Wrench	Torque
1/4"	19 mm	39.18 N·m (28.90 lb ft)
3/8"	22 mm	49.08 N·m (36.20 lb ft)
1/2"	27 mm	93.14 N·m (68.70 lb ft)
3/4"	36 mm	176.26 N·m (130.00 lb ft)
1"	41 mm	206.08 N·m (152.00 lb ft)
1-1/4"	50 mm	343.02 N·m (253.00 lb ft)

## Torque - Special torque settings

Code	Component		Bolt size	Wrench	Tightening torque
1	Travel motor		M12 x 1.75	19 mm	88 – 113 N·m (65.10 – 83.18 lb ft)
2	Sprocket		M12 x 1.75	19 mm	88 – 113 N·m (65.10 – 83.18 lb ft)
3	Idler wheel		M8 x 1.25	13 mm	29 – 35 N·m (21.70 – 26.04 lb ft)
4	Track support roller		M12 x 1.75	19 mm	109 – 132 N·m (80.29 – 97.65 lb ft)
5	Track frame roller		M16 x 2.0	24 mm	262 – 321 N·m (193.12 – 236.52 lb ft)
6	Grease valve cover		M10 x 1.5	17 mm	54 – 81 N·m (39.80 – 60.00 lb ft)
7	Travel motor cover		M10 x 1.5	17 mm	54 – 81 N·m (39.80 – 60.00 lb ft)
8a	Counterweight		M20 x 2.5	30 mm	514 – 642 N·m (379.1 – 473.5 lb ft)
8b	Additional counterweight		M24 x 3.0	36 mm	850 – 1150 N·m (626.9 – 848.2 lb ft)
9	Swing bearing		M12 x 1.75	19 mm	109 – 132 N·m (80.29 – 97.65 lb ft)
10	Swing unit		M16 x 2.0	24 mm	252 – 342 N·m (185.9 – 252.2 lb ft)
11	Engine	Mount (front)	M12 x 1.75	19 mm	120 – 140 N·m (88.5 – 103.3 lb ft)
12		Front bracket	M10 x 1.25	17 mm	59 – 89 N·m (43.5 – 65.6 lb ft)
13		Mount (coupling)	M12 x 1.75	19 mm	90 – 95 N·m (66.4 – 70.1 lb ft)
14	Radiator		M12 x 1.75	19 mm	96 – 156 N·m (71.00 – 115.00 lb ft)
15	Hydraulic pump	Pump	M12 x 1.75	19 mm	90 – 110 N·m (66.4 – 81.1 lb ft)
16	Hydraulic oil tank		M12 x 1.75	19 mm	98 – 158 N·m (72.3 – 116.5 lb ft)
17	Fuel tank		M8 x 1.25	13 mm	20 – 29 N·m (14.50 – 21.70 lb ft)
18			M12 x 1.75	19 mm	73 – 110 N·m (53.60 – 81.00 lb ft)
19			M12 x 1.75	19 mm	98 – 158 N·m (72.3 – 116.5 lb ft)
20	Main control valve		M10 x 1.5	17 mm	54 – 81 N·m (39.83 – 59.74 lb ft)
21	Main control valve (bracket)		M10 x 1.5	17 mm	54 – 81 N·m (39.83 – 59.74 lb ft)
22	Hydraulic swivel		M10 x 1.5	17 mm	54 – 81 N·m (39.83 – 59.74 lb ft)
23	Remote control valve - Hand control lever		M6 x 1	10 mm	8 – 12 N·m (6.15 – 9.05 lb ft)
24	Remote control valve - Dozer lever		M8 x 1.25	13 mm	20 – 29 N·m (14.50 – 21.70 lb ft)
25	Remote control valve - Boom swing pedal		M8 x 1.25	13 mm	20 – 29 N·m (14.50 – 21.70 lb ft)
26	Remote control valve - Travel pedal		M8 x 1.25	13 mm	20 – 29 N·m (14.50 – 21.70 lb ft)
27	Cab		M12 x 1.75	19 mm	98 – 158 N·m (72.3 – 116.5 lb ft)

INTRODUCTION

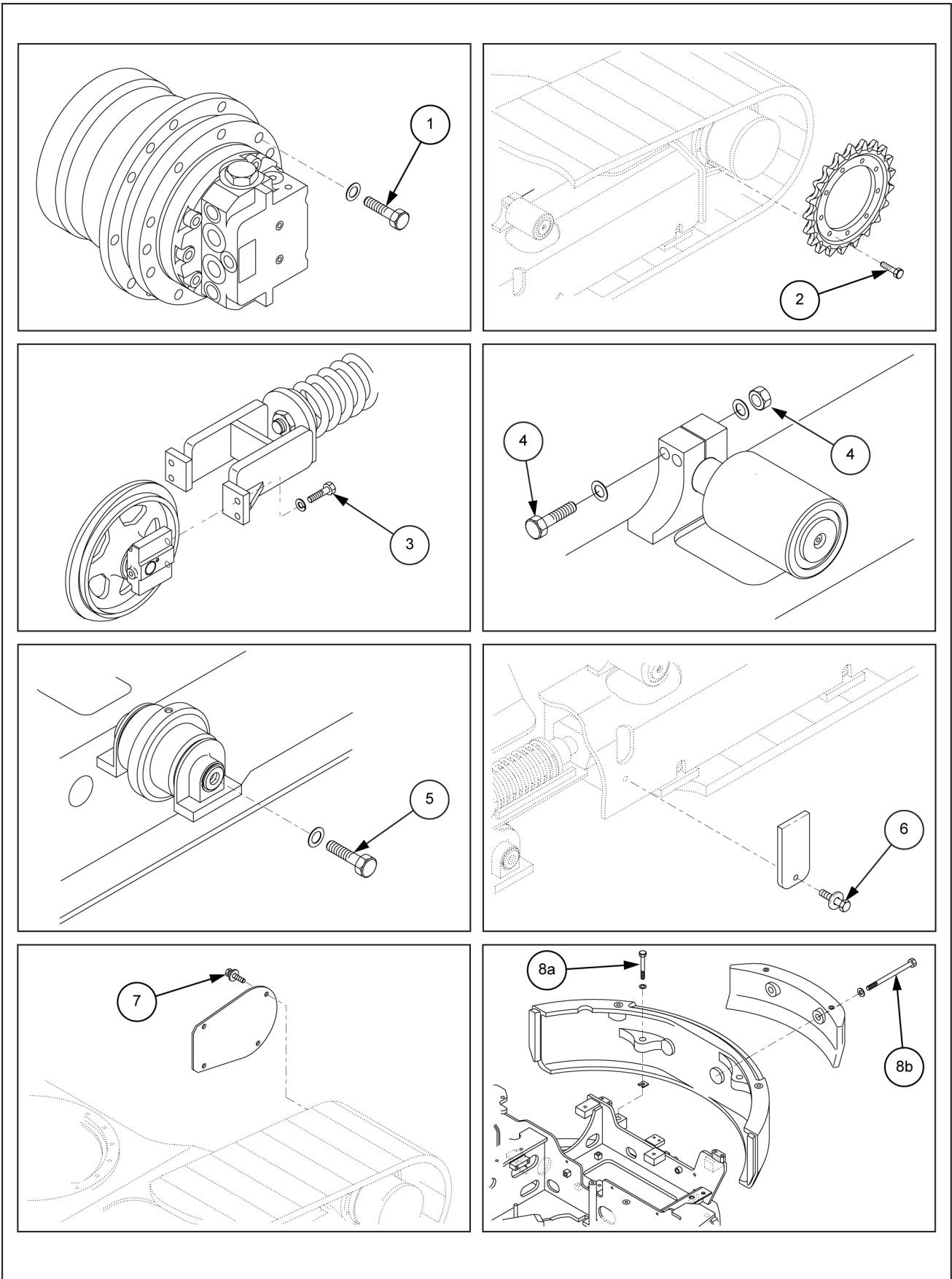

SMIL16MEX1225HB 1

# INTRODUCTION

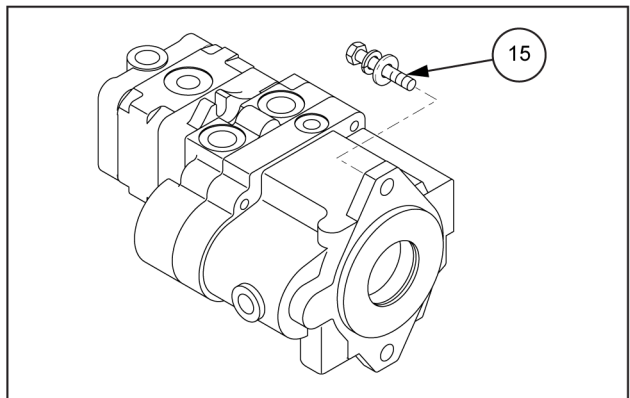
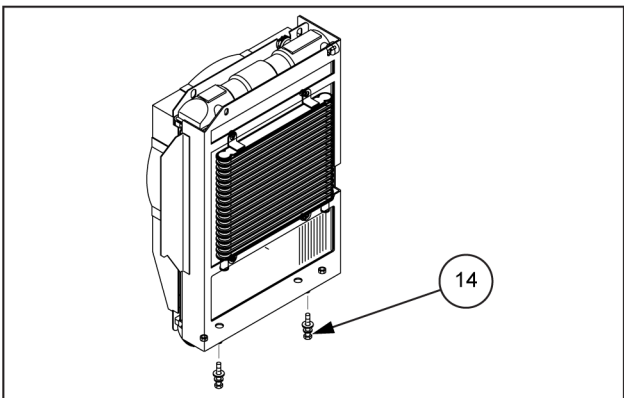
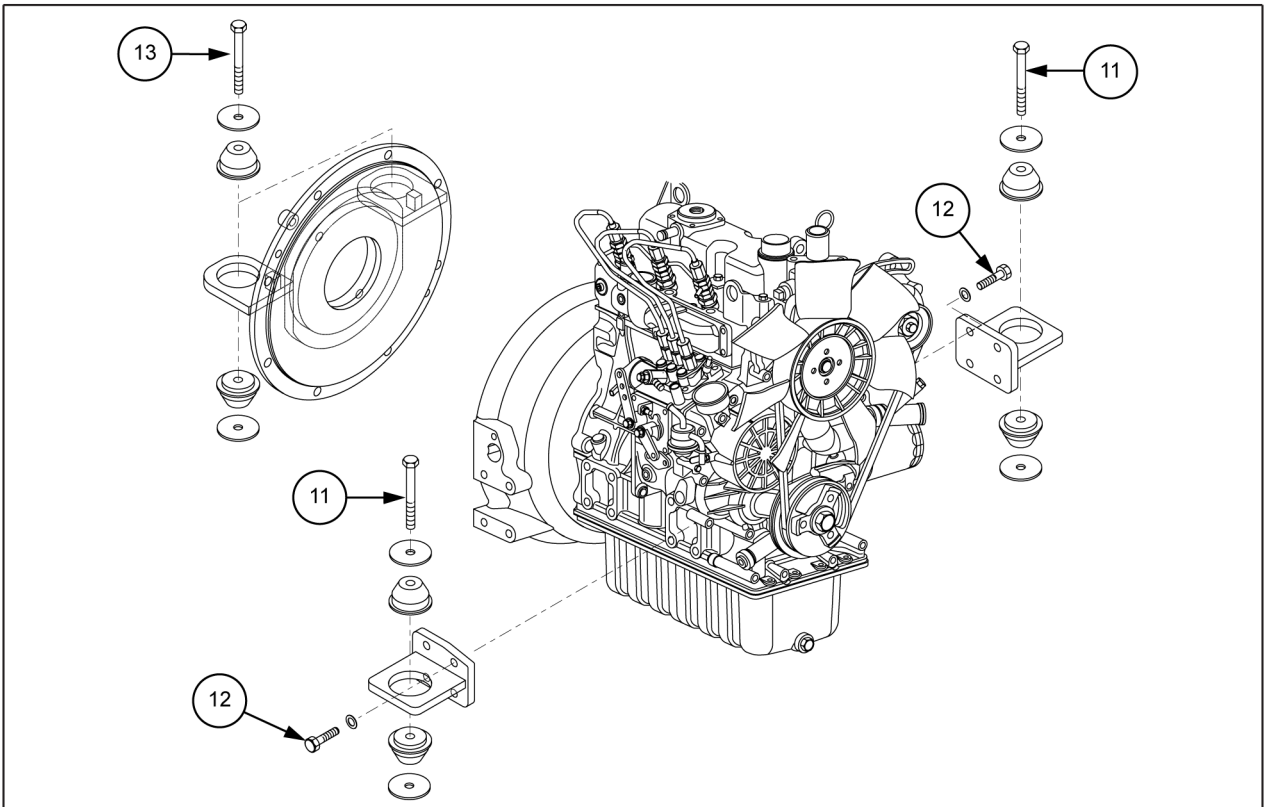
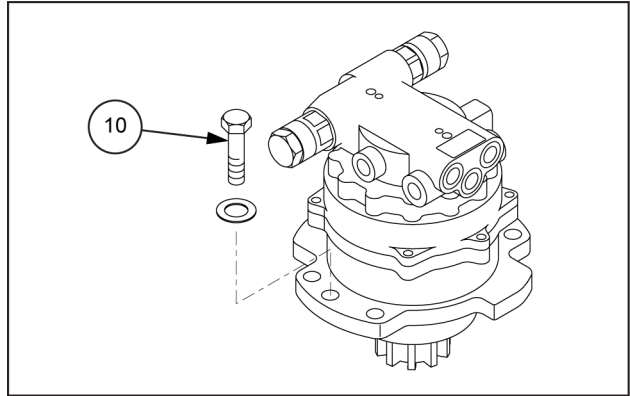
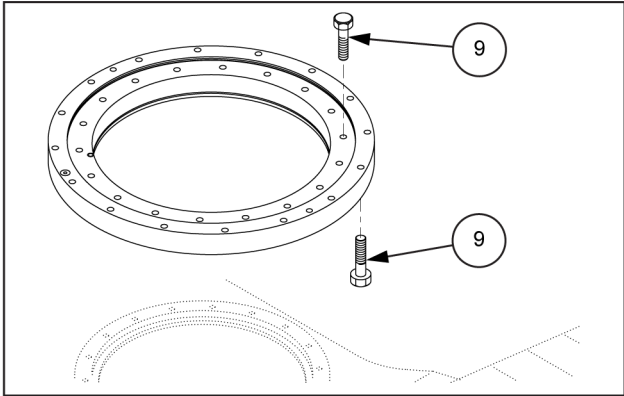

SMIL16MEX1226HB 2

INTRODUCTION

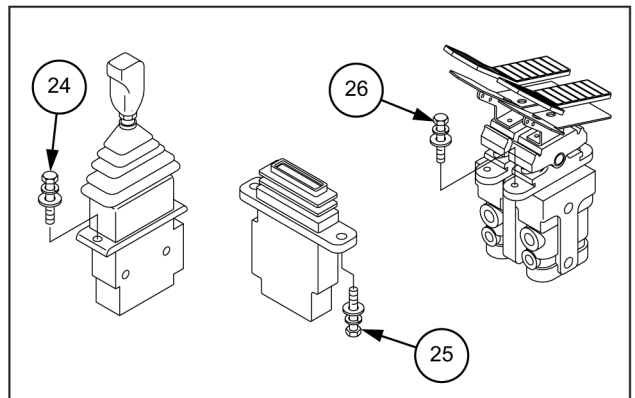
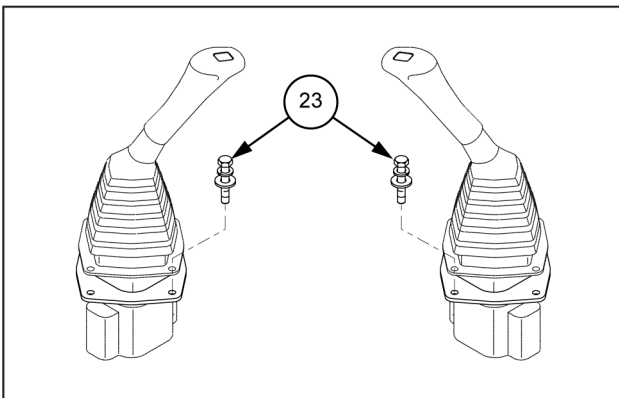
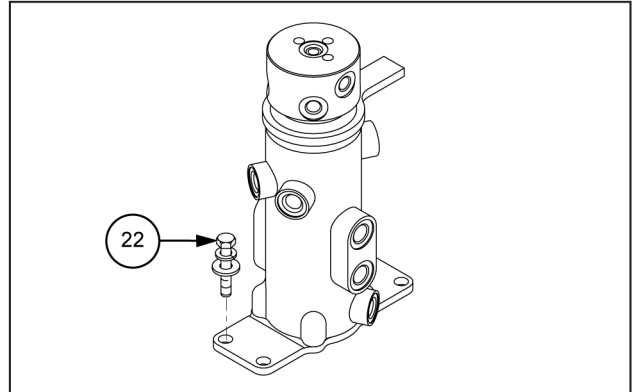
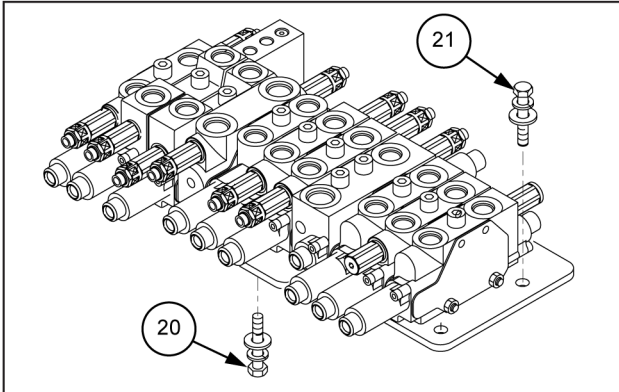
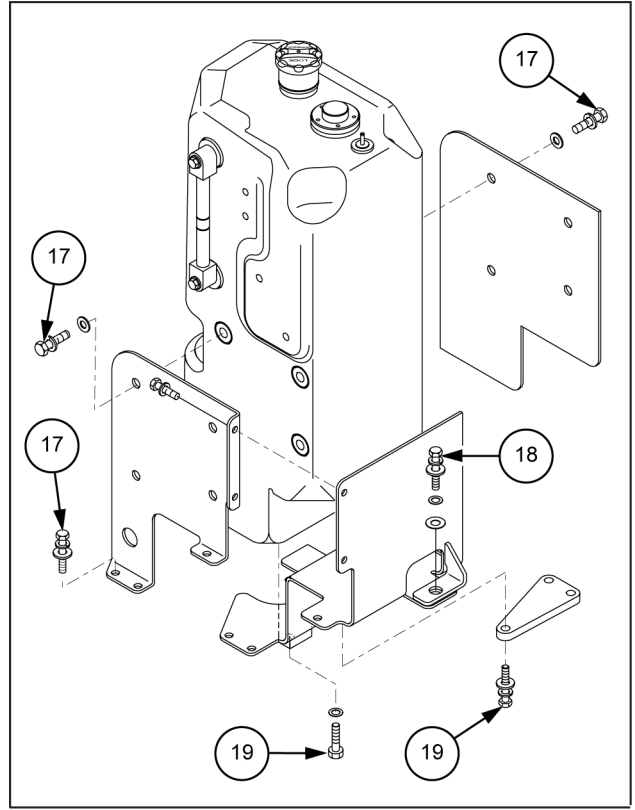
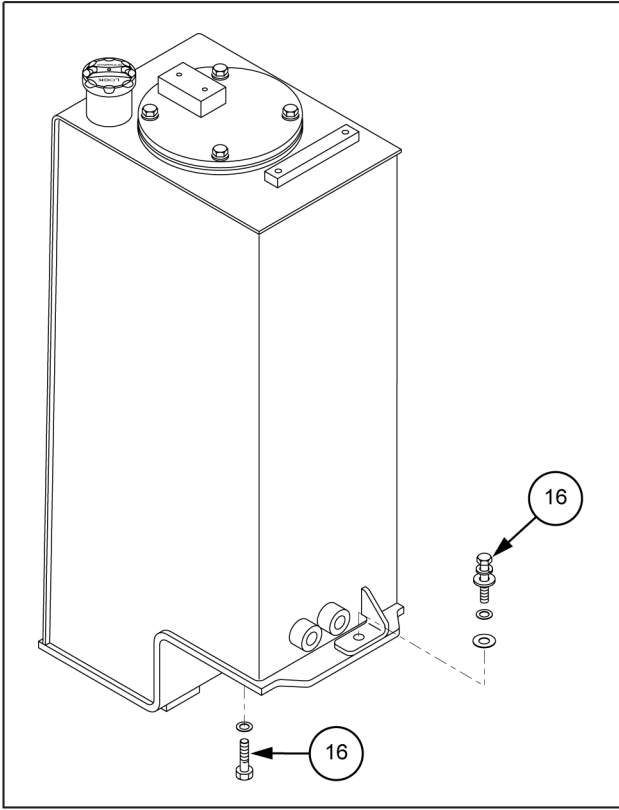

INTRODUCTION

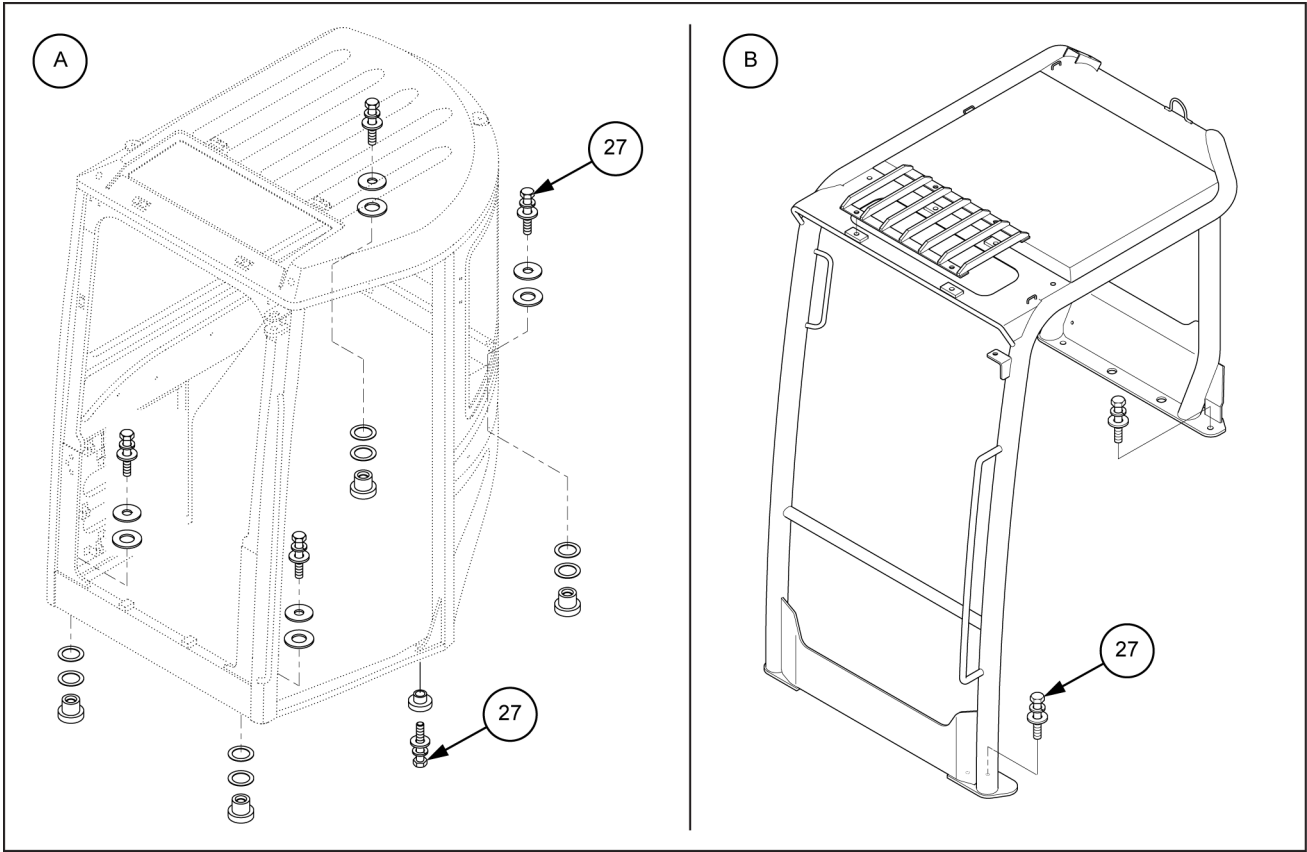

SMIL16MEX1228FB 4

- A. Cab version
- B. Canopy version

---

## Basic instructions - Shop and assembly

### Shimming

For each adjustment operation, select adjusting shims and measure the adjusting shims individually using a micrometer, then add up the recorded values. Do not rely on measuring the entire shimming set, which may be incorrect, or the rated value shown on each shim.

### Rotating shaft seals

For correct rotating shaft seal installation, proceed as follows:

1. Before assembly, allow the seal to soak in the oil it will be sealing for at least thirty minutes.
2. Thoroughly clean the shaft and check that the working surface on the shaft is not damaged.
3. Position the sealing lip facing the fluid.

**NOTE:** *With hydrodynamic lips, take into consideration the shaft rotation direction and position the grooves so that they will move the fluid towards the inner side of the seal.*

4. Coat the sealing lip with a thin layer of lubricant (use oil rather than grease). Fill the gap between the sealing lip and the dust lip on double lip seals with grease.
5. Insert the seal in its seat and press down using a flat punch or seal installation tool. Do not tap the seal with a hammer or mallet.
6. While you insert the seal, check that the seal is perpendicular to the seat. When the seal settles, make sure that the seal makes contact with the thrust element, if required.
7. To prevent damage to the seal lip on the shaft, position a protective guard during installation operations.

### O-ring seals

Lubricate the O-ring seals before you insert them in the seats. This will prevent the O-ring seals from overturning and twisting, which would jeopardize sealing efficiency.

### Sealing compounds

Apply a sealing compound on the mating surfaces when specified by the procedure. Before you apply the sealing compound, prepare the surfaces as directed by the product container.

### Spare parts

Only use CNH Original Parts or CASE CONSTRUCTION Original Parts.

Only genuine spare parts guarantee the same quality, duration, and safety as original parts, as they are the same parts that are assembled during standard production. Only CNH Original Parts or CASE CONSTRUCTION Original Parts can offer this guarantee.

When ordering spare parts, always provide the following information:

- Machine model (commercial name) and Product Identification Number (PIN)
- Part number of the ordered part, which can be found in the parts catalog

---

## Protecting the electronic and/or electrical systems during charging and welding

To avoid damage to the electronic and/or electrical systems, always observe the following practices:

1. Never make or break any of the charging circuit connections when the engine is running, including the battery connections.
2. Never short any of the charging components to ground.
3. Always disconnect the ground cable from the battery before arc welding on the machine or on any machine attachment.
  - Position the welder ground clamp as close to the welding area as possible.
  - If you weld in close proximity to a computer module, then you should remove the module from the machine.
  - Never allow welding cables to lie on, near, or across any electrical wiring or electronic component while you weld.
4. Always disconnect the negative cable from the battery when charging the battery in the machine with a battery charger.

**NOTICE:** *If you must weld on the unit, you must disconnect the battery ground cable from the machine battery. The electronic monitoring system and charging system will be damaged if this is not done.*

5. Remove the battery ground cable. Reconnect the cable when you complete welding.

### **WARNING**

**Battery acid causes burns. Batteries contain sulfuric acid.**

**Avoid contact with skin, eyes or clothing. Antidote (external): Flush with water. Antidote (eyes): flush with water for 15 minutes and seek medical attention immediately. Antidote (internal): Drink large quantities of water or milk. Do not induce vomiting. Seek medical attention immediately. Failure to comply could result in death or serious injury.**

W0111A

## Special tools

The special tools that CASE CONSTRUCTION suggests and illustrate in this manual have been specifically researched and designed for use with CASE CONSTRUCTION machines. The special tools are essential for reliable repair operations. The special tools are accurately built and rigorously tested to offer efficient and long-lasting operation.

By using these tools, repair personnel will benefit from:

- Operating in optimal technical conditions
- Obtaining the best results
- Saving time and effort
- Working in safe conditions

## Machine specifications

### Engine

Model	Kubota D1305
Type	4-cycle vertical overhead valve, diesel fuel
Cooling method	Water cooling
Number of cylinders and arrangement	3 cylinders, in-line
Firing order	1 - 2 - 3
Combustion chamber type	Swirl chamber type
Cylinder bore x stroke	<b>78 mm (3.07 in) x 88 mm (3.46 in)</b>
Piston displacement	<b>1261 cm<sup>3</sup> (77 in<sup>3</sup>)</b>
Compression ratio	24 : 1
Rated gross horse power ( SAE J1995)	<b>18.5 kW (25.2 Hp) at 2400 RPM</b>
Maximum torque at <b>1600 RPM</b>	<b>81.4 N·m (60.0 lb ft)</b>
Engine oil quantity	<b>5.7 L (1.5 US gal)</b>
Dry weight	<b>124 kg (273 lb)</b>
High idling speed	<b>2300 – 2400 RPM</b>
Low idling speed	<b>1425 – 1475 RPM</b>
Rated fuel consumption	192 g/Hp·hr at <b>2400 RPM</b> ( 257 g/kW·hr at <b>2400 RPM</b> )
Starting motor	<b>12 V, 1.4 kW</b>
Alternator	<b>12 V, 40 A</b>
Battery	<b>1 x 12 V x 58 A·h ( 5 h rating)</b>

### Main pump

Type	Variable displacement tandem axis piston pumps
Capacity	<b>2 x 12 cm<sup>3</sup>/rev (0.7 in<sup>3</sup>/rev)</b>
Rated oil flow	<b>2 x 27.6 L/min (7.3 US gpm)</b>
Rated speed	<b>2300 RPM</b>

### Gear pump

Type	Fixed displacement gear pump single stage
Capacity	<b>8.5 – 4.5 cm<sup>3</sup>/rev (0.5 – 0.3 in<sup>3</sup>/rev)</b>
Rated oil flow	<b>19.6 – 10.4 L/min (5.2 – 2.7 US gpm)</b>

### Main control valve

Type	Sectional, 9 spools (12 blocks)
Operating method	Hydraulic pilot system
Main relief valve pressure : P1, P2 / P3	<b>21573 – 17161 kPa (3129 – 2489 psi)</b>
Overload relief valve pressure	<b>23538 kPa (3414 psi)</b>

## Swing motor

Type	Fixed displacement axial piston motor
Capacity	<b>12.5 cm<sup>3</sup>/rev (0.8 in<sup>3</sup>/rev)</b>
Relief pressure	<b>16671 kPa (2418 psi)</b>
Braking system	Automatic, spring applied hydraulic released
Braking torque	<b>68 N·m (50.2 lb ft)</b>
Brake release pressure	<b>2454 – 4902 kPa (356 – 711 psi)</b>
Reduction gear type	2 - stage planetary

## Travel motor

Type	Variable displacement axial piston motor
Relief pressure	<b>21573 kPa (3129 psi)</b>
Reduction gear type	2-stage planetary
Braking system	Automatic, spring applied hydraulic released
Brake release pressure	<b>1861 kPa (270 psi)</b>
Braking torque	<b>55.9 N·m (41.2 lb ft)</b>

## Cylinder

Boom cylinder	Bore diameter x Rod diameter x Stroke	<b>75 mm (3.0 in) x 45 mm (1.8 in) x 562 mm (22.1 in)</b>
	Cushion	Extend only
Arm cylinder	Bore diameter x Rod diameter x Stroke	<b>Ø 70 mm (2.8 in) x Ø 45 mm (1.8 in) x 500 mm (19.7 in)</b>
	Cushion	Extend and retract
Bucket cylinder	Bore diameter x Rod diameter x Stroke	<b>Ø 55 mm (2.2 in) x Ø 35 mm (1.4 in) x 420 mm (16.5 in)</b>
	Cushion	-
Boom swing cylinder	Bore diameter x Rod diameter x Stroke	<b>Ø 75 mm (3.0 in) x Ø 40 mm (1.6 in) x 400 mm (15.7 in)</b>
	Cushion	-
Dozer cylinder	Bore diameter x Rod diameter x Stroke	<b>Ø 95 mm (3.7 in) x Ø 50 mm (2.0 in) x 140 mm (5.5 in)</b>
	Cushion	-

**NOTE:** discoloration of cylinder rod can occur when the friction reduction additive of lubrication oil spreads on the rod surface.

Discoloration does not cause any harmful effect on the cylinder performance.

## Types of shoes – Cab version

Shoe width	<b>300 mm (11.8 in)</b>
Ground pressure	<b>28.4 kPa (4.1 psi)</b>
Overall width	<b>1550 mm (61 in)</b>

## Types of shoes – Canopy version

Shoe width	<b>300 mm (11.8 in)</b>
Ground pressure	<b>26.5 kPa (3.8 psi)</b>
Overall width	<b>1550 mm (61 in)</b>

## Number of rollers and shoes on each side

Upper roller	1
Lower roller	3

## Weights

### Machine

Operating weight – Cab version (standard boom, arm, bucket, lubricant, coolant, full fuel, full hydraulic, without quick coupler, rubber track)	<b>3000 kg (6613.9 lb)</b>
Operating weight – Canopy version (standard boom, arm, bucket, lubricant, coolant, full fuel, full hydraulic, without quick coupler, rubber track)	<b>2890 kg (6371.4 lb)</b>

### Components

Upperstructure assembly	<b>1640 kg (3615.6 lb)</b>
Main frame weld assembly	<b>310 kg (683.4 lb)</b>
Engine assembly	<b>136 kg (299.8 lb)</b>
Main pump assembly	<b>19 kg (42 lb)</b>
Main control valve assembly	<b>25 kg (55 lb)</b>
Swing motor assembly	<b>34 kg (75 lb)</b>
Hydraulic oil tank assembly	<b>35 kg (77.2 lb)</b>
Fuel tank assembly	<b>15 kg (33.1 lb)</b>
Boom swing post	<b>80 kg (176.4 lb)</b>
Counterweight	<b>220 kg (485 lb)</b>
Cab assembly	<b>210 kg (463 lb)</b>
Lower chassis assembly	<b>910 kg (2006.2 lb)</b>
Track frame weld assembly	<b>400 kg (881.8 lb)</b>
Swing bearing	<b>50 kg (110.2 lb)</b>
Travel motor assembly	<b>36 kg (79 lb)</b>
Turning joint	<b>11 kg (24 lb)</b>
Track recoil spring	<b>14 kg (30.9 lb)</b>
Idler	<b>21 kg (46.3 lb)</b>
Carrier roller	<b>3 kg (7 lb)</b>
Track roller	<b>10 kg (22 lb)</b>
Sprocket	<b>7 kg (15 lb)</b>
Rubber track ( <b>300 mm (11.8 in)</b> )	<b>146.2 kg (322.3 lb)</b>
Dozer blade assembly	<b>125 kg (275.6 lb)</b>
Front attachment assembly ( <b>2.030 m (79.921 in)</b> boom, <b>1.12 m (44.1 in)</b> arm, <b>0.08 m<sup>3</sup> (0.10 yd<sup>3</sup>)</b> SAE heaped bucket)	<b>330 kg (727.5 lb)</b>
<b>2.030 m (79.921 in)</b> boom assembly	<b>94 kg (207.2 lb)</b>
<b>1.12 m (44.1 in)</b> arm assembly	<b>54 kg (119 lb)</b>
<b>0.08 m<sup>3</sup> (2.83 ft<sup>3</sup>)</b> SAE heaped bucket	<b>62 kg (136.7 lb)</b>
Boom cylinder assembly	<b>26 kg (57 lb)</b>
Arm cylinder assembly	<b>26 kg (57 lb)</b>
Bucket cylinder assembly	<b>20 kg (44 lb)</b>
Bucket control link assembly	<b>20 kg (44 lb)</b>
Dozer cylinder assembly	<b>24 kg (52.9 lb)</b>
Boom swing cylinder assembly	<b>23 kg (51 lb)</b>

## Dimensions

### Cab version

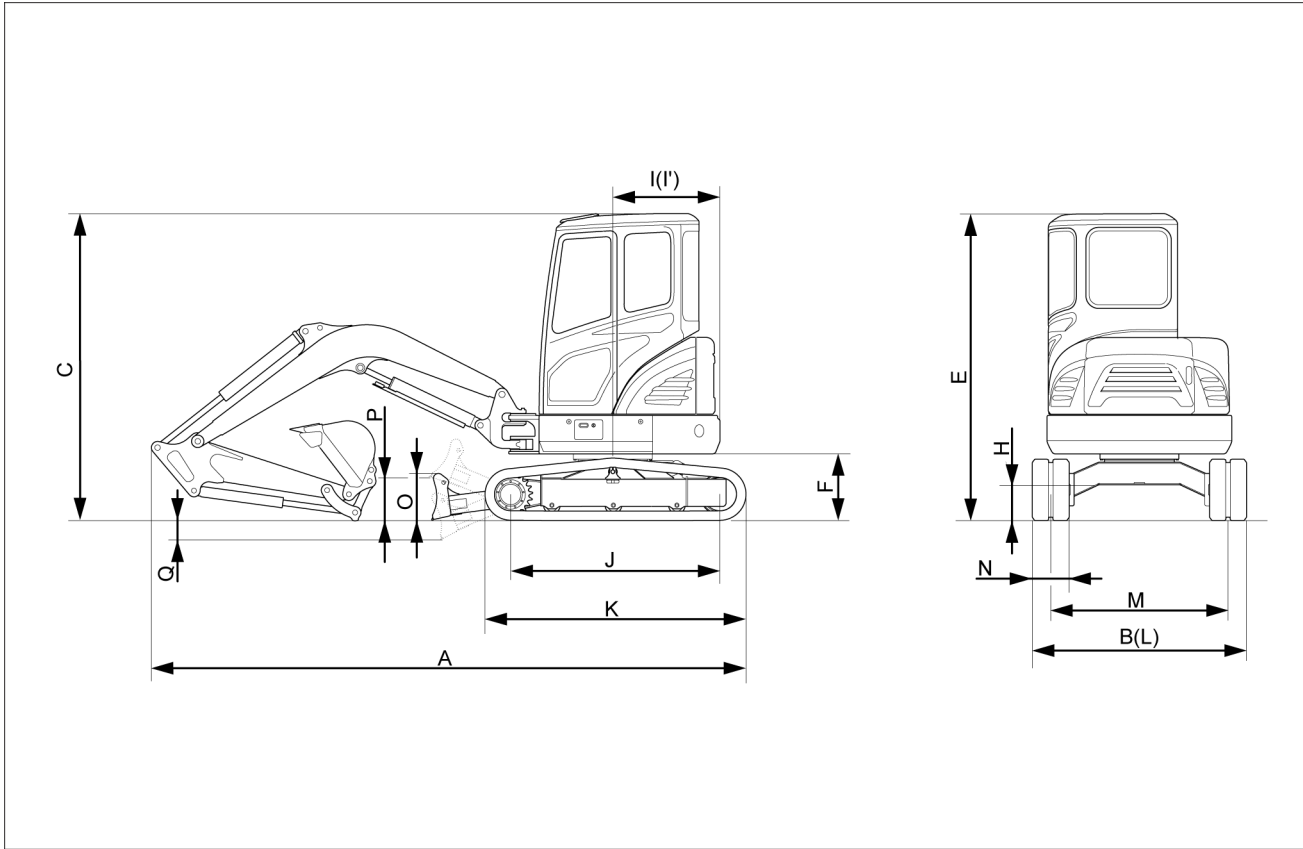

SMIL16MEX0048FA 1

<b>(A)</b> Overall length	<b>4180 mm (164.6 in)</b>
<b>(B)</b> Overall width, with <b>300.0 mm (11.8 in)</b> shoe	<b>1550 mm (61.0 in)</b>
<b>(C)</b> Overall height	<b>2500 mm (98.4 in)</b>
<b>(E)</b> Overall height of cab	<b>2500 mm (98.4 in)</b>
<b>(F)</b> Ground clearance of counterweight	<b>540 mm (21.3 in)</b>
<b>(H)</b> Minimum ground clearance	<b>290 mm (11.4 in)</b>
<b>(I)</b> Rear-end distance	<b>775 mm (30.5 in)</b>
<b>(I')</b> Rear-end swing radius	<b>775 mm (30.5 in)</b>
<b>(J)</b> Distance between tumbler	<b>1550 mm (61.0 in)</b>
<b>(K)</b> Undercarriage length	<b>1970 mm (77.6 in)</b>
<b>(L)</b> Undercarriage width	<b>1500 mm (59.1 in)</b>
<b>(M)</b> Track gauge	<b>1250 mm (49.2 in)</b>
<b>(N)</b> Track shoe width, standard	<b>300 mm (11.8 in)</b>
<b>(O)</b> Height of blade	<b>300 mm (11.8 in)</b>
<b>(P)</b> Ground clearance of blade up	<b>350 mm (13.8 in)</b>
<b>(Q)</b> Depth of blade down	<b>370 mm (14.6 in)</b>

Boom length: **2.030 m (79.921 in)**

Arm length: **1.120 m (44.094 in)**

With boom swing post

**Canopy version**

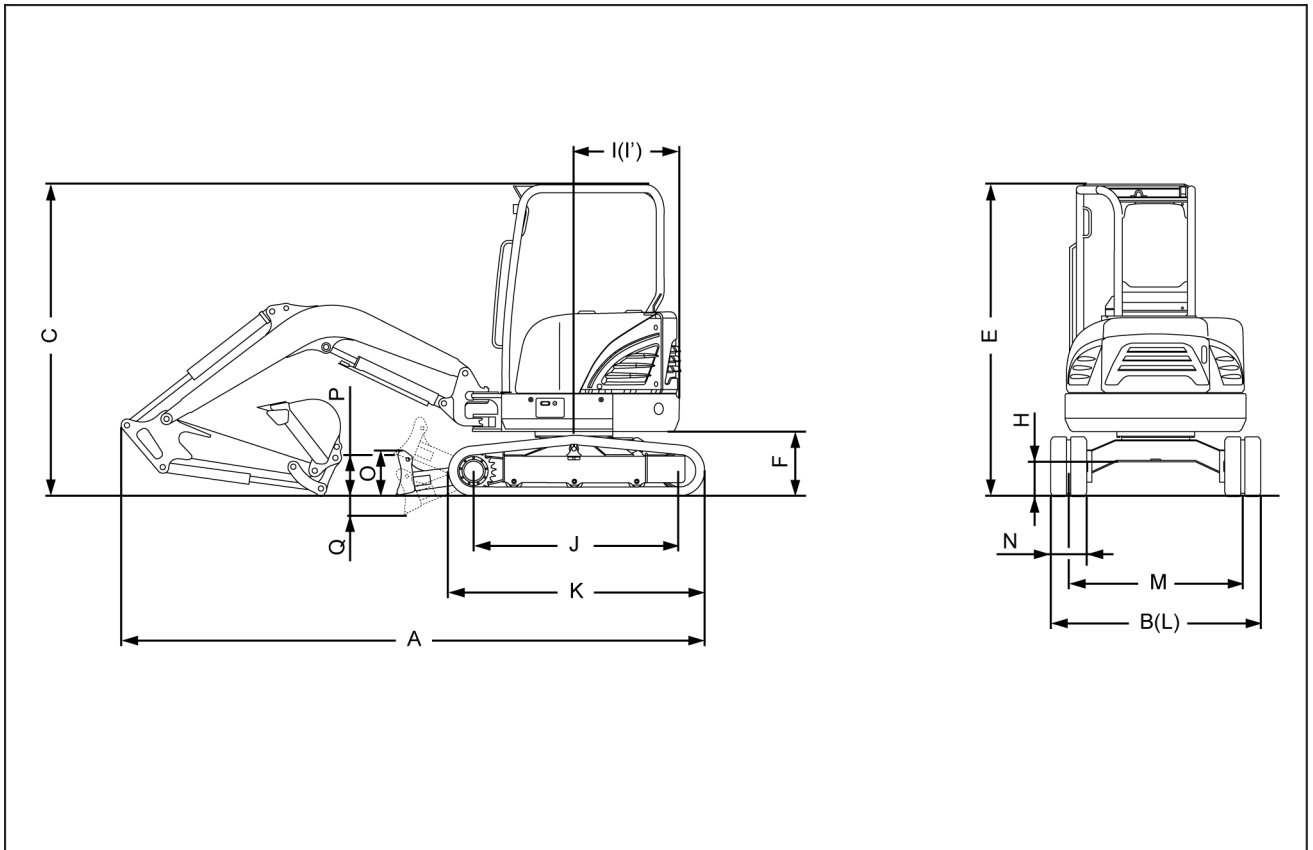

SMIL16MEX1545FA 2

<b>(A)</b> Overall length	<b>4180 mm (164.6 in)</b>
<b>(B)</b> Overall width, with <b>300.0 mm (11.8 in)</b> shoe	<b>1550 mm (61.0 in)</b>
<b>(C)</b> Overall height	<b>2500 mm (98.4 in)</b>
<b>(E)</b> Overall height of cab	<b>2500 mm (98.4 in)</b>
<b>(F)</b> Ground clearance of counterweight	<b>540 mm (21.3 in)</b>
<b>(H)</b> Minimum ground clearance	<b>290 mm (11.4 in)</b>
<b>(I)</b> Rear-end distance	<b>775 mm (30.5 in)</b>
<b>(I')</b> Rear-end swing radius	<b>775 mm (30.5 in)</b>
<b>(J)</b> Distance between tumblers	<b>1550 mm (61.0 in)</b>
<b>(K)</b> Undercarriage length	<b>1970 mm (77.6 in)</b>
<b>(L)</b> Undercarriage width	<b>1500 mm (59.1 in)</b>
<b>(M)</b> Track gauge	<b>1250 mm (49.2 in)</b>
<b>(N)</b> Track shoe width, standard	<b>300 mm (11.8 in)</b>
<b>(O)</b> Height of blade	<b>300 mm (11.8 in)</b>
<b>(P)</b> Ground clearance of blade up	<b>350 mm (13.8 in)</b>
<b>(Q)</b> Depth of blade down	<b>370 mm (14.6 in)</b>

Boom length: **2.030 m (79.921 in)**

Arm length: **1.120 m (44.094 in)**

With boom swing post

**Working range**

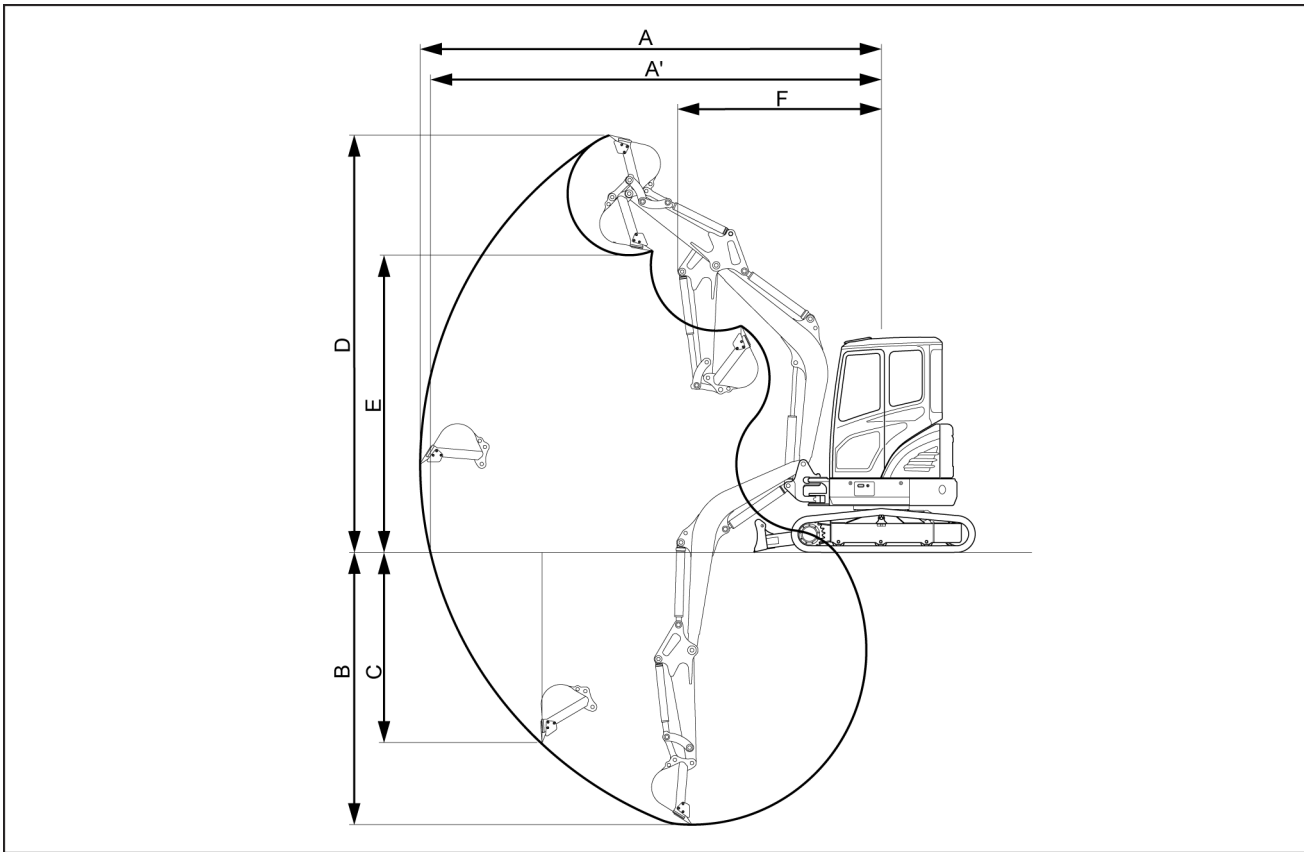

SMIL16MEX0049FA 3

<b>(A)</b> Maximum digging reach		<b>4650 mm (183.1 in)</b>
<b>(A')</b> Maximum digging reach on ground		<b>4515 mm (177.8 in)</b>
<b>(B)</b> Maximum digging depth		<b>2500 mm (98.4 in)</b>
<b>(C)</b> Maximum vertical wall digging depth		<b>2085 mm (82.1 in)</b>
<b>(D)</b> Maximum digging height		<b>4270 mm (168.1 in)</b>
<b>(E)</b> Maximum dumping height		<b>2890 mm (113.8 in)</b>
<b>(F)</b> Minimum swing radius		<b>2055 mm (80.9 in)</b>
Boom swing radius (left-hand/right-hand)		<b>75° / 50°</b>
Bucket digging force	SAE	<b>17.9 kN (4024.1 lb)</b>
	ISO	<b>20.1 kN (4518.7 lb)</b>
Arm crowd force	SAE	<b>13.1 kN (2945.0 lb)</b>
	ISO	<b>13.7 kN (3079.9 lb)</b>

Boom length: **1.945 m (76.575 in)**

Arm length: **1.120 m (44.094 in)**

With boom swing post

## Conversion factors

### Unit conversion rate

Gravitational unit	- x → ← ÷ -	SI unit
kgf	9.807	N
lbf	4.448	N
kgf·cm	0.0981	N·m
lbf·ft	1.356	N·m
lbf·in	0.113	N·m
kgf/cm <sup>2</sup>	0.0981	MPa
atm	0.1013	MPa
lbf/in <sup>2</sup>	0.0069	MPa
mm Hg	133.3	Pa
in Hg	3386	Pa
kgf·m/s	0.00981	kW
lbf·ft/s	0.00136	kW
PS	0.7355	kW
HP	0.746	kW
kgf·m	9.807	J
kcal	4186	J
kgf·s/cm <sup>2</sup>	98067	Pa·s
cP	0.001	Pa·s
P	0.1	Pa·s
cSt	1 x 10 <sup>-6</sup>	m <sup>2</sup> /s
St	0.0001	m <sup>2</sup> /s

### Length

#### Millimeters to inches

mm	In.	mm	In.	mm	In.	mm	In.
1	0.0394	26	1.0236	51	2.0079	76	2.9921
2	0.0787	27	1.0630	52	2.0472	77	3.0315
3	0.1181	28	1.1024	53	2.0866	78	3.0709
4	0.1575	29	1.1417	54	2.1260	79	3.1102
5	0.1969	30	1.1811	55	2.1654	80	3.1496
6	0.2362	31	1.2205	56	2.2047	81	3.1890
7	0.2756	32	1.2598	57	2.2441	82	3.2283
8	0.3150	33	1.2992	58	2.2835	83	3.2677
9	0.3543	34	1.3386	59	2.3228	84	3.3071
10	0.3937	35	1.3780	60	2.3622	85	3.3465
11	0.4331	36	1.4173	61	2.4016	86	3.3858
12	0.4724	37	1.4567	62	2.4409	87	3.4252
13	0.5118	38	1.4961	63	2.4803	88	3.4646
14	0.5512	39	1.5354	64	2.5197	89	3.5039
15	0.5906	40	1.5748	65	2.5591	90	3.5433
16	0.6299	41	1.6142	66	2.5984	91	3.5827
17	0.6693	42	1.6535	67	2.6378	92	3.6220
18	0.7087	43	1.6929	68	2.6772	93	3.6614
19	0.7480	44	1.7323	69	2.7165	94	3.7008
20	0.7874	45	1.7717	70	2.7559	95	3.7402
21	0.8268	46	1.8110	71	2.7953	96	3.7795
22	0.8661	47	1.8504	72	2.8346	97	3.8189
23	0.9055	48	1.8898	73	2.8740	98	3.8583
24	0.9449	49	1.9291	74	2.9134	99	3.8976
25	0.9843	50	1.9685	75	2.9528	100	3.9370

Sample manual. Download All pages at:

<https://www.arepairmanual.com/downloads/2017-case-cx30c-mini-excavator-service-manual-48175013/>