

WX148 Wheeled Excavator

SERVICE MANUAL

Sample manual. Download All pages at:

<https://www.arepairmanual.com/downloads/2016-case-wx148-wheeled-excavator-service-manual-48005353/>

Part number 48005353

English

April 2016

© 2016 CNH Industrial Italia S.p.A. All Rights Reserved.

CASE
CONSTRUCTION

Product: 2016 Case WX148 Wheeled Excavator Service Manual 48005353
Full Download: <https://www.arepairmanual.com/downloads/2016-case-wx148-wheeled-excavator-service-manual-48005353/>



SERVICE MANUAL

WX148

Sample manual. Download All pages at:

<https://www.arepairmanual.com/downloads/2016-case-wx148-wheeled-excavator-service-manual-48005353/>

48005353 27/04/2016

Link Product / Engine

Product	Market Product	Engine
WX148 Wheeled excavator Mono Tier3 MY2013 - Nef 4 CYL Mech	Middle East Africa	F4GE9484
WX148 Wheeled excavator Mono Tier3 MY2013 - Nef 4 CYL Mech	Europe	F4GE9484
WX148 Wheeled excavator 2PB Tier3 MY2013 - Nef 4 CYL Mech	Europe	F4GE9484
WX148 Wheeled excavator 2PB Tier3 MY2013 - Nef 4 CYL Mech	Asia Pacific	F4GE9484
WX148 Wheeled excavator 2PB Tier3 MY2013 - Nef 4 CYL Mech	Middle East Africa	F4GE9484
WX148 Wheeled excavator Mono Tier3 MY2013 - Nef 4 CYL Mech	Asia Pacific	F4GE9484

Contents

INTRODUCTION

Engine	10
[10.202] Air cleaners and lines	10.1
[10.206] Fuel filters	10.2
[10.216] Fuel tanks	10.3
[10.218] Fuel injection system.....	10.4
[10.254] Intake and exhaust manifolds and muffler	10.5
[10.310] Aftercooler.....	10.6
[10.400] Engine cooling system	10.7
Transmission	21
[21.105] Powershift transmission lubrication system	21.1
[21.113] Powershift transmission	21.2
[21.135] Powershift transmission external controls.....	21.3
[21.155] Powershift transmission internal components.....	21.4
Four-Wheel Drive (4WD) system	23
[23.314] Drive shaft.....	23.1
Front axle system	25
[25.100] Powered front axle	25.1
[25.102] Front bevel gear set and differential	25.2
[25.108] Final drive hub, steering knuckles, and shafts	25.3
[25.122] Axle suspension control.....	25.4
Rear axle system	27
[27.100] Powered rear axle.....	27.1
[27.106] Rear bevel gear set and differential.....	27.2
[27.120] Planetary and final drives	27.3
Brakes and controls	33

[33.110] Parking brake or parking lock	33.1
[33.202] Hydraulic service brakes	33.2
Hydraulic systems.....	35
[35.000] Hydraulic systems.....	35.1
[35.106] Variable displacement pump	35.2
[35.300] Reservoir, cooler, and filters.....	35.3
[35.304] Combination pump units	35.4
[35.352] Hydraulic swing system	35.5
[35.353] Hydraulic travel system	35.6
[35.354] Hydraulic central joint	35.7
[35.357] Pilot system	35.8
[35.359] Main control valve.....	35.9
[35.360] Hammer and rotating bucket hydraulic system	35.10
[35.703] Stabilizer hydraulic system.....	35.11
[35.730] Positioning arm hydraulic system	35.12
[35.736] Boom hydraulic system	35.13
[35.737] Dipper hydraulic system.....	35.14
[35.738] Excavator and backhoe bucket hydraulic system.....	35.15
[35.741] Dozer blade cylinders	35.16
Frames and ballasting	39
[39.103] Swing ring assembly	39.1
[39.129] Stabilizers	39.2
[39.140] Ballasts and supports	39.3
Steering.....	41
[41.101] Steering control	41.1
[41.106] Tie rods.....	41.2
[41.200] Hydraulic control components.....	41.3
[41.216] Cylinders	41.4

Wheels	44
[44.511] Front wheels	44.1
[44.520] Rear wheels	44.2
Cab climate control	50
[50.200] Air conditioning	50.1
Electrical systems	55
[55.000] Electrical system	55.1
[55.010] Fuel injection system	55.2
[55.011] Fuel tank system	55.3
[55.012] Engine cooling system	55.4
[55.014] Engine intake and exhaust system	55.5
[55.015] Engine control system	55.6
[55.020] Transmission speed sensors	55.7
[55.036] Hydraulic system control	55.8
[55.050] Heating, Ventilation, and Air-Conditioning (HVAC) control system	55.9
[55.100] Harnesses and connectors	55.10
[55.110] Electrical rotary joint	55.11
[55.302] Battery	55.12
[55.404] External lighting	55.13
[55.416] Swing control system	55.14
[55.425] Boom, dipper, and bucket control system	55.15
[55.512] Cab controls	55.16
[55.514] Cab lighting	55.17
[55.525] Cab engine controls	55.18
[55.530] Camera	55.19
[55.640] Electronic modules	55.20
Booms, dippers, and buckets	84
[84.100] Bucket	84.1

[84.910] Boom	84.2
Dozer blade and arm.....	86
[86.110] Dozer blade	86.1
Platform, cab, bodywork, and decals	90
[90.118] Protections and footboards.....	90.1
[90.124] Pneumatically-adjusted operator seat.....	90.2
[90.150] Cab	90.3
[90.151] Cab interior.....	90.4



INTRODUCTION

Contents

INTRODUCTION

Foreword - Important notice regarding equipment servicing	3
Safety rules	4
Personal safety	5
Torque	14
Basic instructions - Shop and assembly	23
Basic instructions - How to use the maintenance standard and precautions	25
Basic instructions - Precaution for disassembly and assembly	27
Basic instructions - Electrical equipment precautions	29
General specification	30
Fluids and lubricants	35
Capacities	38
Hydraulic contamination	39
Product identification	40
Product identification - Machine orientation	42
Product overview	43

Foreword - Important notice regarding equipment servicing

All repair and maintenance work listed in this manual must be carried out only by qualified dealership personnel, strictly complying with the instructions given, and using, whenever possible, the special tools.

Anyone who performs repair and maintenance operations without complying with the procedures provided herein shall be responsible for any subsequent damages.

The manufacturer and all the organizations of its distribution chain, including - without limitation - national, regional, or local dealers, reject any responsibility for damages caused by parts and/or components not approved by the manufacturer, including those used for the servicing or repair of the product manufactured or marketed by the manufacturer. In any case, no warranty is given or attributed on the product manufactured or marketed by the manufacturer in case of damages caused by parts and/or components not approved by the manufacturer.

The manufacturer reserves the right to make improvements in design and changes in specifications at any time without notice and without incurring any obligation to install them on units previously sold. Specifications, descriptions, and illustrative material herein are as accurate as known at time of publication but are subject to change without notice.

In case of questions, refer to your CASE CONSTRUCTION Sales and Service Networks.

Safety rules

Personal safety



This is the safety alert symbol. It is used to alert you to potential personal injury hazards. Obey all safety messages that follow this symbol to avoid possible death or injury.

Throughout this manual you will find the signal words DANGER, WARNING, and CAUTION followed by special instructions. These precautions are intended for the personal safety of you and those working with you.

Read and understand all the safety messages in this manual before you operate or service the machine.

 DANGER indicates a hazardous situation that, if not avoided, will result in death or serious injury.

 WARNING indicates a hazardous situation that, if not avoided, could result in death or serious injury.

 CAUTION indicates a hazardous situation that, if not avoided, could result in minor or moderate injury.

FAILURE TO FOLLOW DANGER, WARNING, AND CAUTION MESSAGES COULD RESULT IN DEATH OR SERIOUS INJURY.

Machine safety

NOTICE: Notice indicates a situation that, if not avoided, could result in machine or property damage.

Throughout this manual you will find the signal word Notice followed by special instructions to prevent machine or property damage. The word Notice is used to address practices not related to personal safety.

Information

NOTE: Note indicates additional information that clarifies steps, procedures, or other information in this manual.

Throughout this manual you will find the word Note followed by additional information about a step, procedure, or other information in the manual. The word Note is not intended to address personal safety or property damage.

Personal safety

Carefully read this Manual before proceeding with maintenance, repairs, refuelling or other machine operations.

Repairs have to be carried out only by authorized and instructed staff; specific precautions have to be taken when grinding, welding or when using mallets or heavy hammers.

Not authorized persons are not allowed to repair or carry out maintenance on this machine. Do not carry out any work on the equipment without prior authorization.

Ask your employer about the safety instructions in force and safety equipment.

Nobody should be allowed in the cab during machine maintenance unless he is a qualified operator helping with the maintenance work.

If it is necessary to move the equipment to carry out repairs or maintenance, do not lift or lower the equipment from any other position than the operator's seat.

Never carry out any operation on the machine when the engine is running, except when specifically indicated.

Stop the engine and ensure that all pressure is relieved from hydraulic circuits before removing caps, covers, valves, etc.

All repair and maintenance operations should be carried out with the greatest care and attention.

Service stairs and platforms used in a workshop or in the field should be built in compliance with the safety rules in force.

Any functional disorders, especially those affecting the safety of the machine, should therefore be rectified immediately.

⚠ DANGER

Unexpected movement!

Make sure parking brake is applied. Secure machine with wheel chocks.

Failure to comply will result in death or serious injury.

D0013A

Before performing any work on the machine, attach a maintenance in progress tag. This tag can be applied on the left-hand control lever, safety lever or cab door.

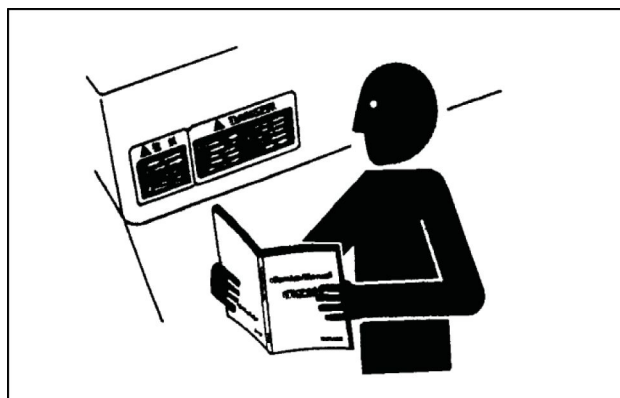

TULI12WEX2004AA 1

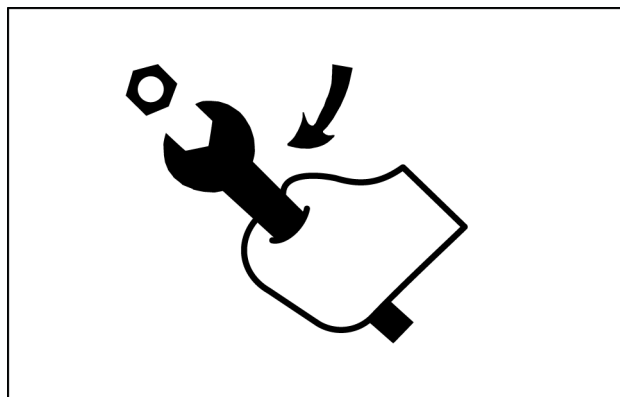

TULI12WEX2005AA 2

Emergency

Be prepared for emergencies. Always keep a fire extinguisher and first aid kit readily available. Ensure that the fire extinguisher is serviced in accordance with the manufacturer's instructions.

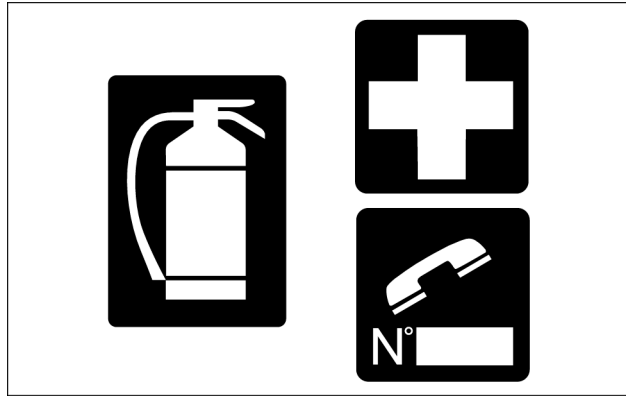

SMIL12WEX0174AA 3

Equipment

Wear close fitting clothing and safety equipment appropriate for the job:

- Safety helmet
- Safety shoes
- Heavy gloves
- Reflective clothing
- Wet weather clothing

If working conditions require, the following personal safety equipment should be on hand:

- Respirators (or dust proof masks)
- Ear plugs or acoustic ears protections
- Goggles with lateral shield or masks for eyes protection

Do not wear rings, wristwatches, jewels, unbuttoned or flapping clothing such as ties, torn clothes, scarves, open jackets or shirts with open zips which could get caught into moving parts.

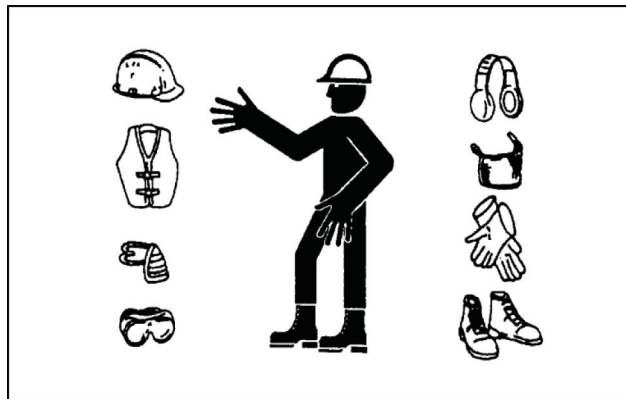

TUL12WEX2008AA 4

Engine - Radiator

Never leave the engine running in enclosed spaces without proper ventilation which is able to evacuate toxic exhaust gases- Keep the exhaust manifold and tube free from combustible materials.

Do not refuel with the engine running, especially if hot, as this increases fire hazard in case of fuel spillage.

Never attempt to check or adjust the belts when the engine is running.

Never lubricate the machine with the engine running.

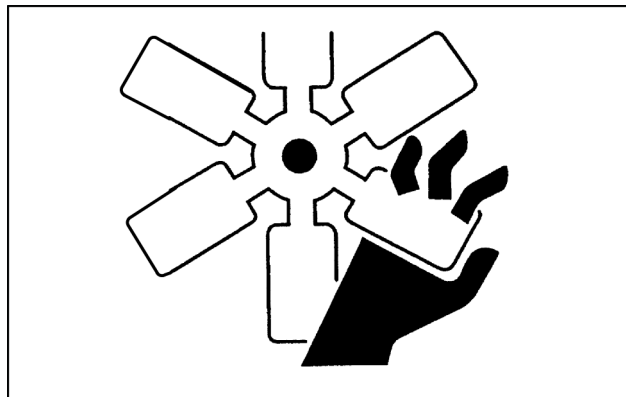

TUL12WEX2009AA 5

Pay attention to rotating components and do not allow to anyone to approach these areas to avoid becoming entangled.

Hands, clothing or tools getting caught in the fan blades or transmission belts, can cause amputations, violent hemorrhages and generate conditions of grave danger. For this reason avoid touching or approaching all rotating or moving parts.

A surging spray of the coolant from the radiator can cause serious burns and scalds.

Before checking the coolant level, shut-off the engine and allow machine to cool down the radiator and hoses. Slowly unscrew the cap to release any residual pressure.

If it is necessary to remove the cap while engine is hot, wear safety clothes and equipment, then loosen the cap slowly to relieve the pressure gradually.

When checking the fuel, oil and coolant levels, use lights and lamps explicitly designated as explosion proof. If these types of lamps are not use, fires or explosions may occur.

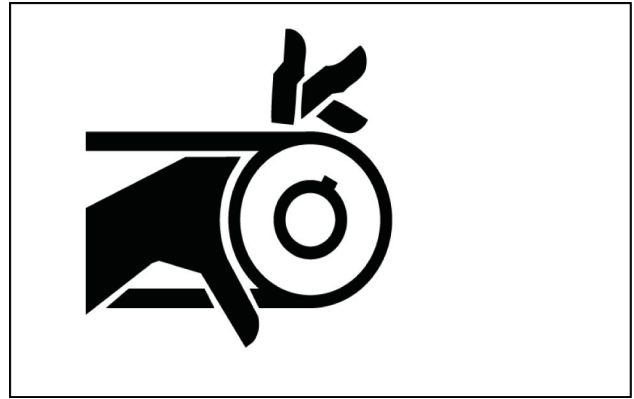

TULI12WEX2010AA 6

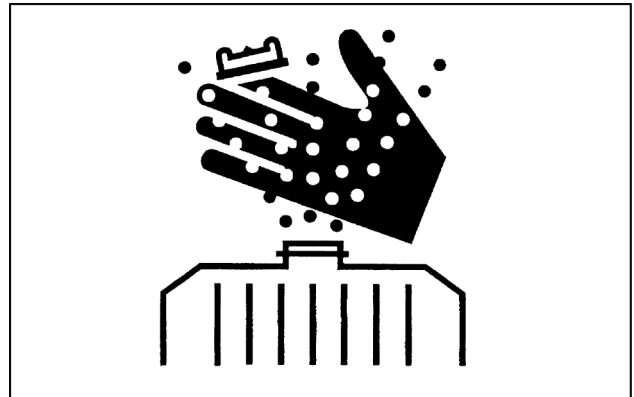

TULI12WEX2011AA 7

Hydraulic systems

Jets of fluids under pressure can penetrate the skin causing serious injuries.

Avoid this hazard by relieving pressure before disconnecting hydraulic or other lines.

Relieve the residual pressure by moving the hydraulic control levers several times.

Tighten all connections before applying pressure.

To protect the eyes wear a facial shield or safety goggles.

Protect your hands and body from possible jets of fluids under pressure.

Swallowing hydraulic oil is a severe health hazard.



TULI12WEX2012AA 8

INTRODUCTION

When hydraulic oil has been swallowed, avoid vomiting, but consult a doctor or go to a hospital.

If an accident occurs, see a doctor familiar with this type of injury immediately.

Any fluid penetrating the skin must be removed within few hours to avoid serious infections.

Flammable splashes may originate because of heating near lines with fluids under pressure, resulting in serious burns. Do not weld or use torches near lines containing fluids or other flammable materials.

Lines under pressure can accidentally be pierced when the heat expands beyond the area immediately heated.

Arrange for temporary fire resistant shields to protect hoses or other components during welding or torch use.

Have any visible leakage repaired immediately.

Discharged oil pollutes the environment. Soak up any oil that has spilled with a proper binding agent. Sweep up binding agent and dispose of it separately from other waste.

Never search for leakages with fingers; instead, use a piece of cardboard and always wear goggles.

Never repair a damaged line; always replace it. Replace hydraulic hoses immediately on detecting any damaged or moist areas.

Always store hydraulic oil in the original containers.

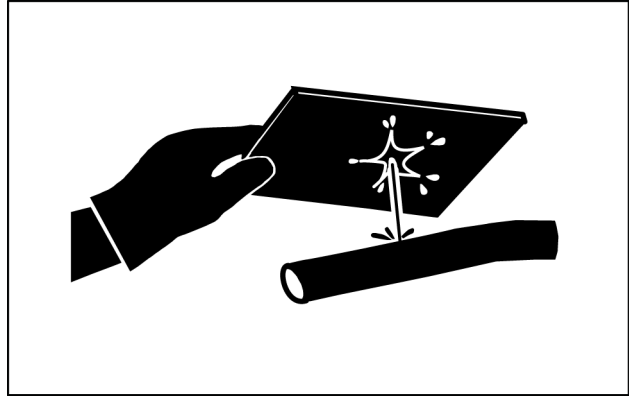

TULI12WEX2013AA 9

Hoses and tubes

Always replace hoses and tubes if the cone end or the end connections on the hose are damaged.

When installing a new hose, loosely connect each end and make sure the hose takes up the correct position before tightening the connections. Clamps should be tightened sufficiently to hold the hose without crushing and to prevent chafing.

After hose replacement to a moving component, check that the hose does not foul by moving the component through the complete range of travel. Be sure any hose which has been installed is not kinked or twisted.

Hose connections which are damaged, dented, crushed or leaking, restrict oil flow and the productivity of the components being served. Connectors which show signs of movement from the original position have failed and will ultimately separate completely.

A hose with a frayed outer sheath will allow water penetration. Concealed corrosion of the wire reinforcement could subsequently occur along the hose length with resultant hose failure.

Ballooning of the hose indicates an internal leakage due to structural failure. This condition rapidly deteriorates and total hose failure soon occurs.

Kinked, crushed, stretched or deformed hoses generally suffer internal structural damage which can result in oil restriction, a reduction in the speed of operation and ultimate hose failure.

Free-moving, unsupported hoses must never be allowed to touch each other or related working surfaces. This causes chafing which reduces hose life.

O-rings

Replace O-rings, seal rings and gaskets whenever they are disassembled.

Never mix new and old seals or O-rings, regardless of condition. Always lubricate new seal rings and O-rings with hydraulic oil before installation to relevant seats.

This will prevent the O-rings from rolling over and twisting during mounting which will jeopardize sealing.

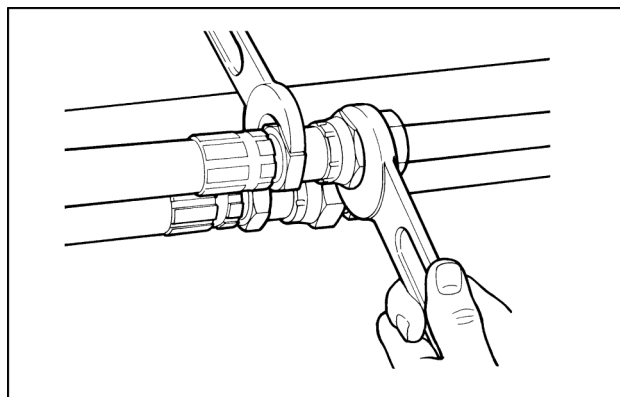

TULI12WEX2014AA 10

Battery

Batteries give off explosive gases.

Never handle naked flames and unshielded light sources near batteries. (No smoking is addressed in next instruction).

To prevent any risk of explosion, observe the following instructions:

- When disconnecting the battery cables, always disconnect the negative (-) cable first.
- To reconnect the battery cables, always connect the negative (-) cable last.
- Never short-circuit the battery terminals with metal objects.
- Do not weld, grind or smoke near a battery.

Battery electrolyte causes severe burns. The battery contains sulphuric acid. Avoid any contact with the skin, eyes or clothing.

Antidote:

- **EXTERNAL:** Rinse well with water, removing any soiled clothing.
- **INTERNAL:** Avoid vomiting. Drink water to rinse your mouth. Consult a doctor.
- **EYES:** Rinse abundantly with water for **15 min** and consult a doctor.
- When the electrolyte of a battery is frozen, it can explode if you attempt to charge the battery or if you try to start the engine using a booster battery. Always keep the battery charged to prevent the electrolyte freezing.

Provide good ventilation when changing a battery or using a battery in an enclosed space. Always protect your eyes when working near a battery.

Never set tools down on the battery. They may induce a short circuit, causing irreparable damage to the battery and injuring persons.

Never wear metal necklaces, bracelets or watch straps when working on the battery. The metal parts may induce a short circuit resulting in burns.

Dispose of used batteries separately from other waste in the interests of environmental protection.

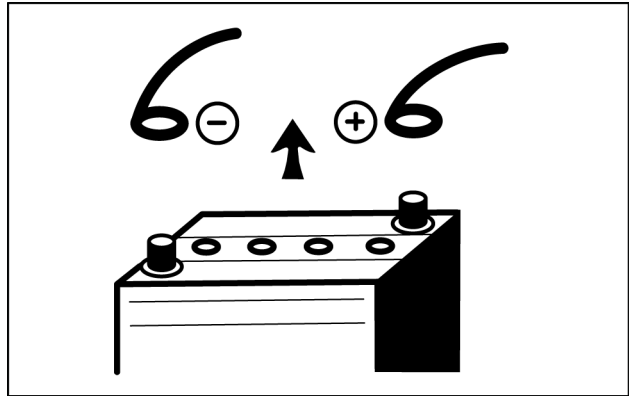

TUL112WEX2015AA 11

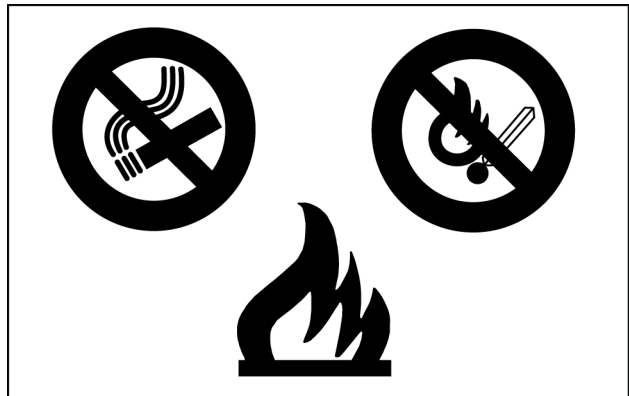

TUL112WEX2016AA 12

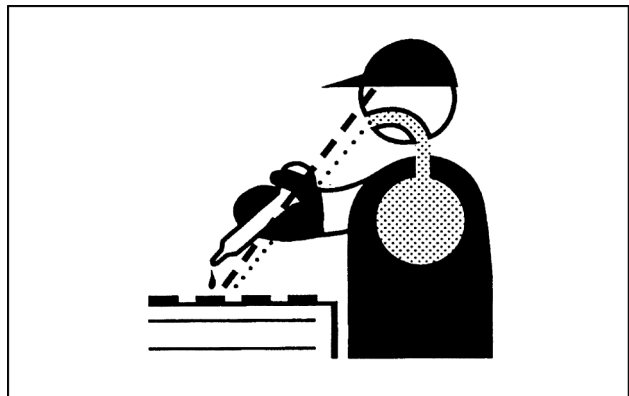

TUL112WEX2017AA 13

Flammable liquids

When handling flammable liquids:

- Do not smoke.
- Keep away from unshielded light sources and naked flames.

Fuels often have a low flash point and are readily ignited.

Never attempt to extinguish burning liquids with water.
Use:

- Dry powder
- Carbon dioxide
- Foam

Water used for extinguishing purposes would vaporize instantaneously on contact with burning substances and spread burning oil, for example, over a wide area. Water generates short circuits in the electrical system, possibly producing new hazards.

Stay away from open flames during refilling of hydraulic oil or fuel.

Fuel or oil spills can cause slipping hazards; thoroughly contain and clean affected areas.

Always tighten the safety plugs of fuel tank and hydraulic oil tank firmly.

Never use fuel to clean machine parts that will be exposed to dirt or debris.

Use a non-flammable product for cleaning parts.

Always perform fuel or oil refilling in well aired and ventilated areas.

During refuelling hold the pistol firmly and always keep it in contact with the filler neck until the end of the refuelling, to avoid arcing due to static electricity.

Do not overfill the tank but leave a space for fuel expansion.

Never refuel when the engine is running.

Take all the necessary safety measures when welding, grinding or when working near a naked flame.



TUL12WEX2016AA 14

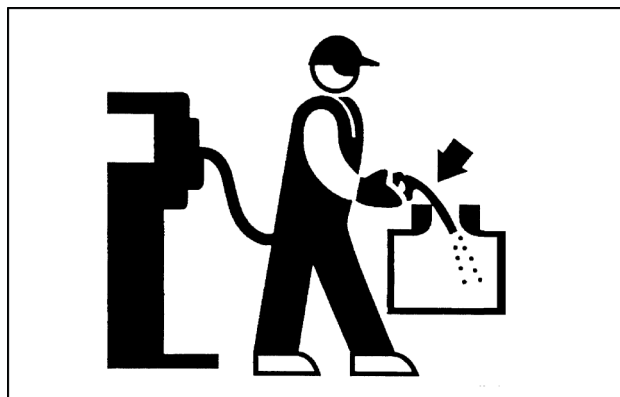

TUL12WEX2018AA 15



TUL12WEX2019AA 16

Tires

Before inflating the tires, always check the condition of rims and the outer condition of tires to find out the presence of dents, cuts, tears of reinforcement plies or other faults. Before inflating a tire, make sure that there are no nearby persons, then position yourself at tread side.

When inflating tires, ensure tire pressure does not exceed that prescribed by the tire manufacturer. Ensure that the pressure of the right tire corresponds to the pressure of the left tire.

NOTE: The front and rear tire pressures may be different.

Never use reconditioned rims because possible welds, heat treatments or brazings not performed correctly can weaken the wheels and cause following damages or failures. Deflate the tires before their disassembly.

Before taking out possible jammed objects from the rims, it is necessary to deflate the tires. Inflate tires by means of an inflation pistol complete with extension and pressure control valve.

Cleaning

Clean the exterior of all components before carrying out any form of repair. Dirt and dust can reduce the efficient working life of a component and lead to costly replacement.

Solvents should be checked that they are suitable for the cleaning of components and also that they do not risk the personal safety of the user.

Dirt, oil, grease and scattered tools are dangerous for people, because they can create slipping or tripping hazards.

For machine cleaning, use a jet of warm water or steam under pressure and commercial detergents. Never use fuel, petroleum or solvents, because they can leave an oily residue that attracts dust, and solvents (even if weak) damage the paint and can lead to the information of rust.

Never use water jets or steam on sensors, connectors or other electric components.

Avoid direct spray of seals and seams to prevent water penetration inside the cab.

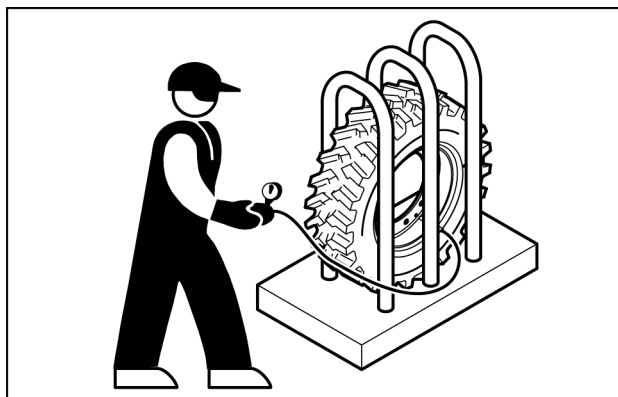

TUL112WEX2020AA 17

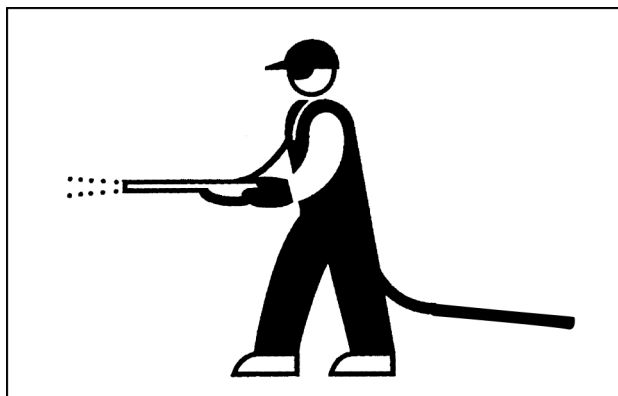

TUL112WEX2021AA 18

Waste disposal

Improperly disposing of waste can threaten the environment.

Each country has its own Regulations on this subject. It is therefore advisable to prepare suitable containers to collect and store momentarily all solid and fluid materials that must not be scattered in the environment to avoid pollution.

At preset intervals these products will be delivered to disposal stations legally recognized and present in this Country.

Hereunder are listed some products of the machine requiring disposal:

- Lubricating oil
- Brake system oil
- Coolant mixture, condensation rests and pure antifreeze
- Fuel
- Filter elements, oil and fuel filters
- Filter elements, air filters
- Battery

Also polluting rags, paper, sawdust and gloves must be disposed in compliance with the same procedures.

Do not use food or beverage containers that may mislead someone into drinking from them. Do not pour waste onto the ground, down a drain, or into any water source. Air conditioning refrigerants escaping into the air can damage the Earth's atmosphere. Government regulations may require a certified air conditioning service centre to recover and recycle used air conditioning refrigerants. Obtain information on the proper way to recycle or dispose of waste from your local environmental or recycling centre, or from your Dealer.

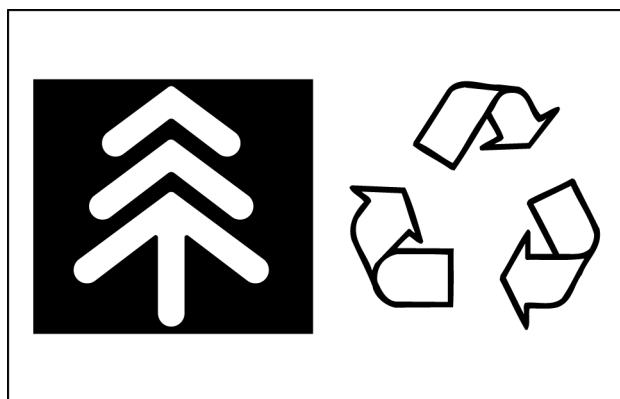

TUL112WEX2022AA 19

Torque

Bolt types

NOTICE: Use tools appropriate for the work to be done. Makeshift tools and procedures can create safety hazards. For loosening and tightening nuts and bolts, use the correct tools. Avoid bodily injury caused by slipping wrenches.

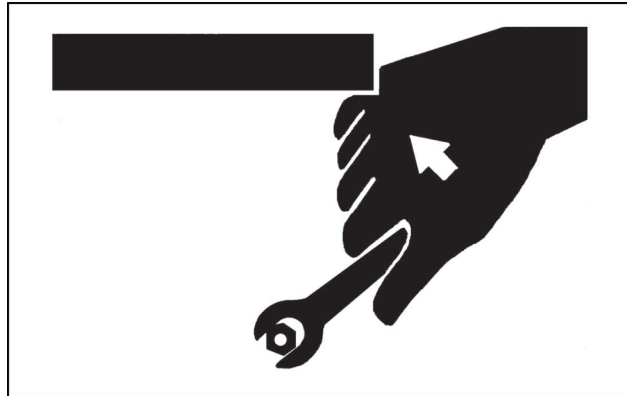

TULI12ECX0475AA 1

Tighten nuts or bolts to torque specifications. There are two kinds of bolts; hexagon T bolts (1) and socket bolts (2). The two types of bolts are made from different materials. The correct type of bolt must be used when assembling the machine and/or components.

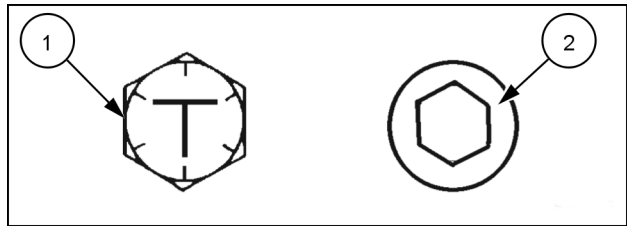

RAPH12CEX1320AA 2

Specified tightening torque chart

Bolt dia.	Wrench size	Hexagon wrench size	T bolt, socket bolt
M8	13 mm	6 mm	29.5 N·m (22 lb ft)
M10	17 mm	8 mm	64 N·m (47 lb ft)
M12	19 mm	10 mm	108 N·m (80 lb ft)
M14	22 mm	12 mm	175 N·m (129 lb ft)
M16	24 mm	14 mm	265 N·m (195 lb ft)
M18	27 mm	14 mm	390 N·m (288 lb ft)
M20	30 mm	17 mm	540 N·m (398 lb ft)
M22	32 mm	17 mm	740 N·m (546 lb ft)
M24	36 mm	19 mm	930 N·m (686 lb ft)
M27	41 mm	19 mm	1370 N·m (1010 lb ft)
M30	46 mm	22 mm	1910 N·m (1409 lb ft)
M33	50 mm	24 mm	2550 N·m (1881 lb ft)
M36	55 mm	27 mm	3140 N·m (2316 lb ft)

1. Apply lubricant (i.e. white zinc B dissolved into spindle oil) to nuts and bolts to stabilize their friction coefficients.
2. Torque tolerance is $\pm 10\%$.
3. Be sure to use bolts of correct length. Bolts that are too long cannot be tightened, as the bolt tip comes into contact with the bottom of the bolt hole. Bolts that are too short cannot develop sufficient tightening force.
4. The torques given in the chart are for general use only.
Do not use these torques if a different torque is given for a specific application.
5. Make sure that the nut and bolt threads are clean before installing. Remove dirt or corrosion, if any.

Bolt tightening order

When tightening two or more bolts, tighten them alternately, as shown, to ensure even tightening.

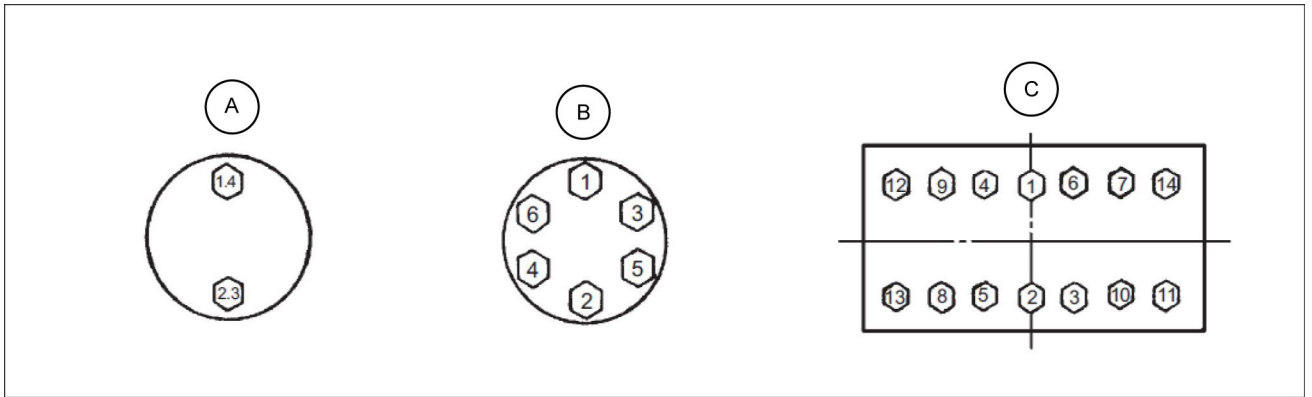

SMIL13CEX0149EA 3

- A Equally tighten upper and lower alternately
- B Tighten diagonally
- C Tighten from center and diagonally

Service recommendations for split flange

1. Be sure to clean and inspect sealing surfaces. Scratches/roughness cause leaks and seal wear. Unevenness causes seal extrusion. If defects cannot be polished out, replace the component.
2. Be sure to use only specified O-rings. Inspect O-rings for any damage. Take care not to file O-ring surfaces. When installing an O-ring into a groove, use grease to hold it in place.
3. Loosely assemble split flange halves. Make sure that the split is centrally located and perpendicular to the port. Hand-tighten the bolts to hold the parts in place. Take care not to pinch the O-ring.
4. Tighten bolts alternately and diagonally, as shown, to ensure even tightening.
5. Do not use air wrenches. Using an air wrench often causes tightening of one bolt fully before tighten the others, resulting in damage to O-rings or uneven tightening of bolts.

A - WRONG

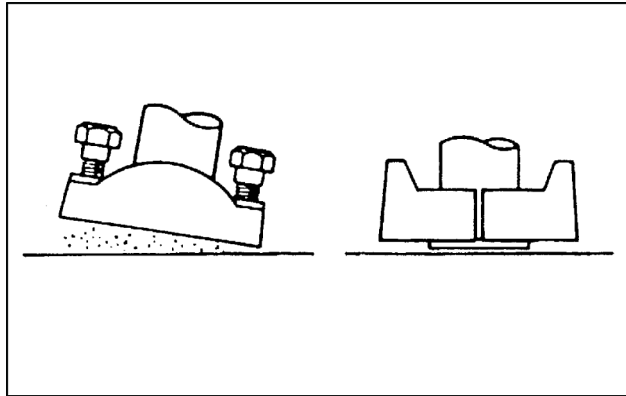

TUL12ECX0802AA 4

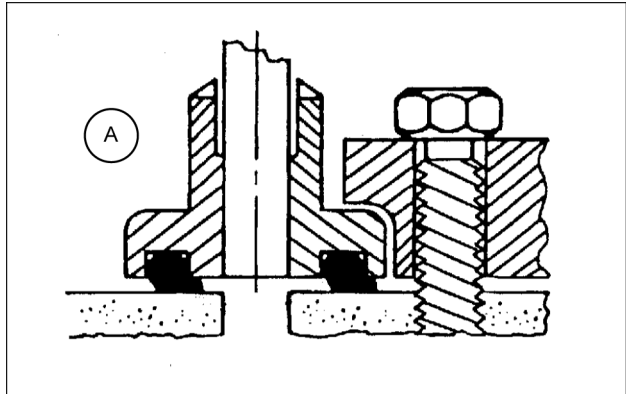

SMIL13CEX0150AA 5

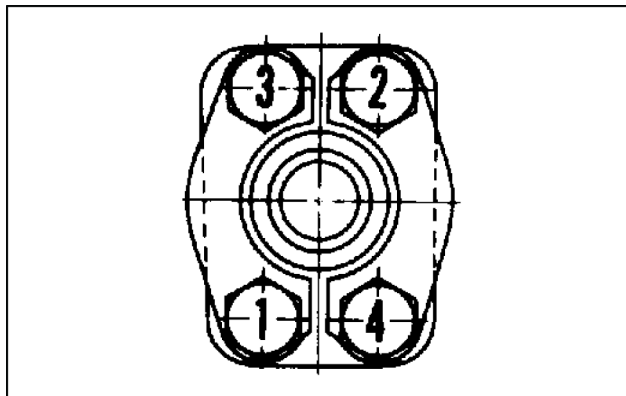

TUL12ECX0804AA 6

Nut and bolt lockings

Lock plate

NOTICE: Do not reuse lock plates. Do not try to bend the same point twice.

Cotter pin

NOTICE: Do not reuse cotter pins. Match the holes in the bolt and nut while tightening, not while loosening.

Lock wire

NOTICE: Apply wire to bolts in the bolt tightening direction, not in the bolt-loosening direction.

A - RIGHT

B - WRONG

C - Bend along edge sharply

D - Do not bend it round

E - Tighten

F - Loosen

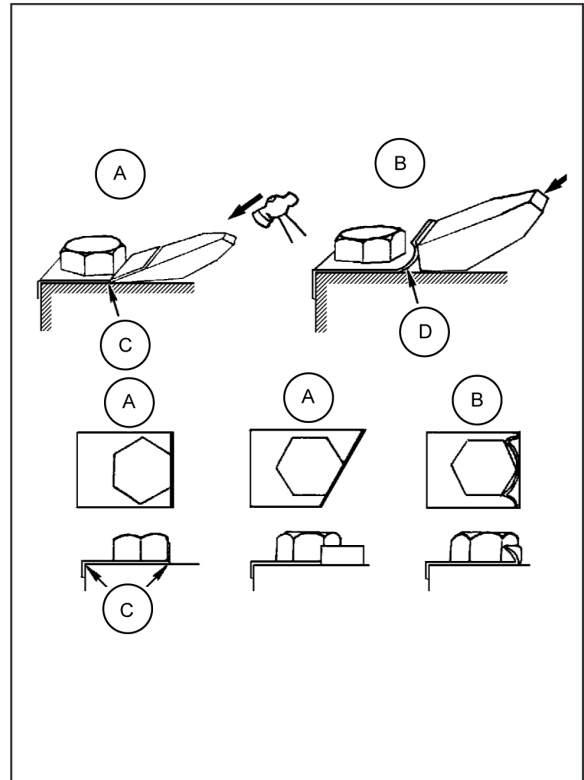

SML13CEX0151BA 7

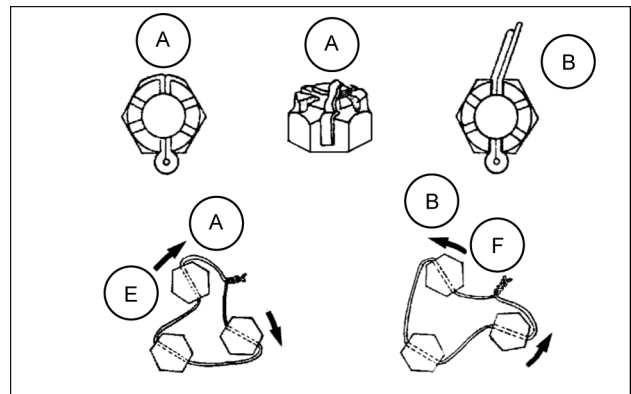

SML13CEX0152AA 8

Piping joint

Pipe thread connection/Union joint tightening torque specifications

Union joint

Metal sealing faces (4) and (5) of adaptor (1) and hose (2) fit together to seal pressure oil. Union joints are used to join small-diameter lines.

1. Do not over tighten union nut (3). Excessive force will be applied to metal sealing surfaces (4) and (5), possibly cracking adaptor (1). Be sure to tighten union nut (3) to specifications.
2. Scratches or other damage to sealing surfaces (4) or (5) will cause oil leakage at the joint. Take care not to damage them when connecting/disconnecting.

A - Joint body

B - Male Union Joint

C - Female Union Joint

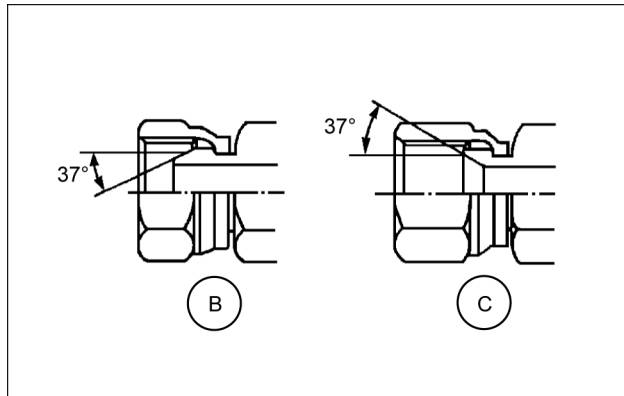
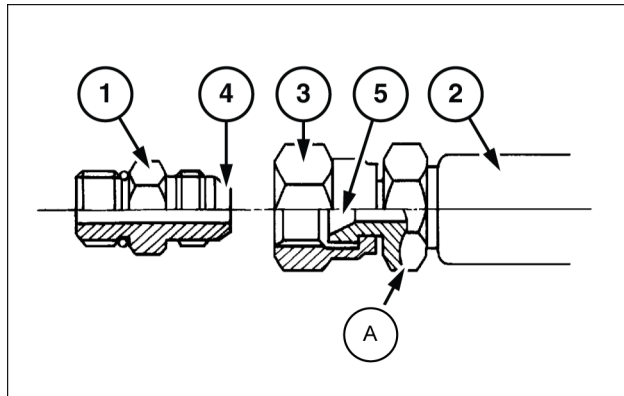

Type	Wrench size		Tightening torque
	Union nut	Joint body	
37° Union joint	19 mm	17 mm	29 N·m (21 lb ft)
	22 mm	19 mm	39 N·m (29 lb ft)
	27 mm	22 mm	78.5 N·m (58 lb ft)
	36 mm	30 mm, 32 mm	157 N·m (116 lb ft)
	41 mm	36 mm	205 N·m (151 lb ft)
	50 mm	46 mm	323.6 N·m (239 lb ft)

NOTE: Tightening torque for the non union type 37° male joint is the same as the 37° female union joint.

O-ring seal joint

O-ring (6) seats against the end face of adaptor (7) to seal pressure oil.

O-ring procedures:

1. Be sure to replace O-ring (6) with a new one when reconnecting.
2. Before tightening union nut (9), confirm that O-ring (6) is seated correctly in O-ring groove (8). Tightening union nut (9) with O-ring (6) displaced will damage O-ring, resulting in oil leakage.
3. Take care not to damage O-ring groove (8) or sealing face (10). Damage to O-ring (6) will cause oil leakage.
4. If union nut (9) is found to be loose, causing oil leakage, do not tighten it to stop the leak. Instead, replace O-ring (6) with a new one, then tighten union nut (9) after confirming that O-ring (6) is securely seated in place.

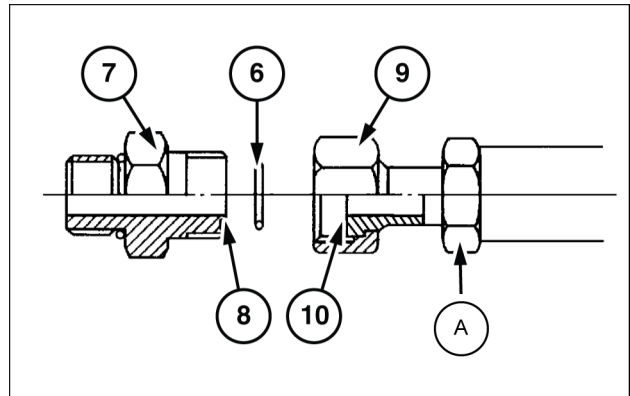

SMIL13CEX0155AB 11

A Joint body

Wrench size		Tightening torque
Union nut	Joint body	
19 mm	17 mm	29.4 N·m (22 lb ft)
22 mm	19 mm	68.6 N·m (51 lb ft)
27 mm	22 mm	93 N·m (69 lb ft)
30 mm	27 mm	137.3 N·m (101 lb ft)
36 mm	30 mm	175 N·m (129 lb ft)
41 mm	36 mm	205 N·m (151 lb ft)
50 mm	46 mm	320 N·m (236 lb ft)

Screwed-in connection

NOTICE: Many types of screwed-in connections are used for hose connections.

Be sure to confirm that the thread pitch and thread type (tapered or straight) are the correct type before using any screw-in connection.

A - Male Tapered Thread

B - Female Straight Thread

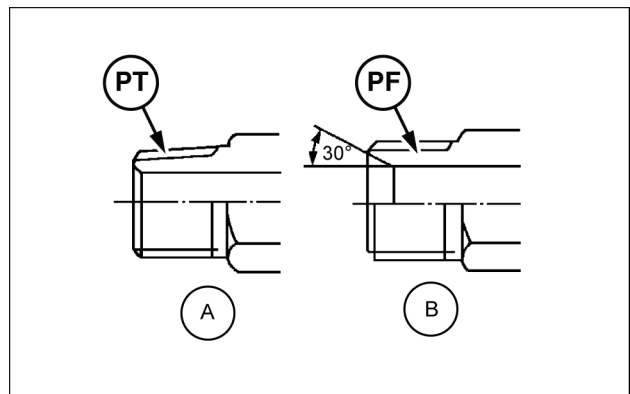

SMIL13CEX0156AB 12

Male tapered thread		Tightening torque
Wrench joint body		
17 mm, 19 mm		34 N·m (25 lb ft)
22 mm		49 N·m (36 lb ft)
27 mm		93 N·m (69 lb ft)
32 mm, 36 mm		157 N·m (116 lb ft)
41 mm		205 N·m (151 lb ft)
50 mm		320 N·m (236 lb ft)
60 mm		410 N·m (302 lb ft)

Seal tape application

Seal tape is used to seal clearances between male and female threads, so as to prevent any leakage between threads.

Be sure to apply just enough seal tape to fill up thread clearances. Do not overwrap.

- Application procedure

Confirm that the thread surface is clean, free of dirt or damage.

Apply seal tape around threads as shown. Wrap seal tape in the same direction as the threads.

A - Internal Thread

B - External Thread

C - Clearance

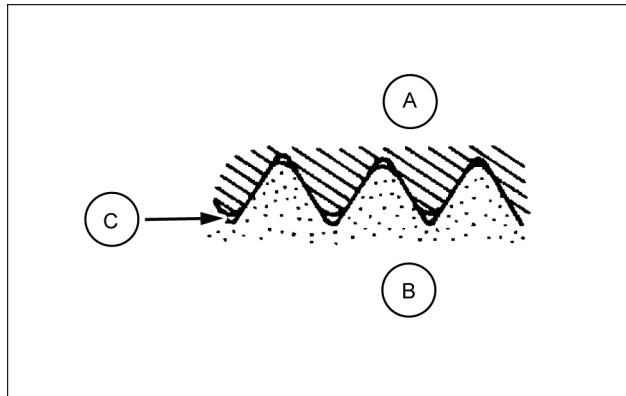

SMIL13CEX0157AB 13

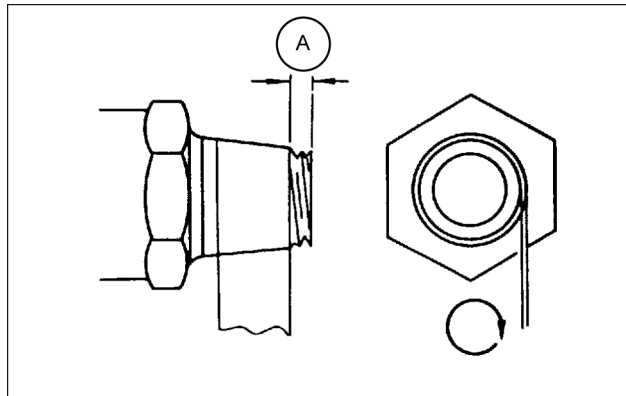

SMIL13CEX0158AA 14

A Leave one to two pitch threads uncovered

Low-pressure-hose clamp tightening torque

Low-pressure-hose clamp tightening torque differs depending on the type of clamp.

See below for correct tightening torque of each type of low-pressure-hose clamp.

T-bolt type band clamp: **4.4 N·m (3.25 lb ft)**

Worm gear type band clamp: **5.9 - 6.9 N·m (4.4 - 5.1 lb ft)**

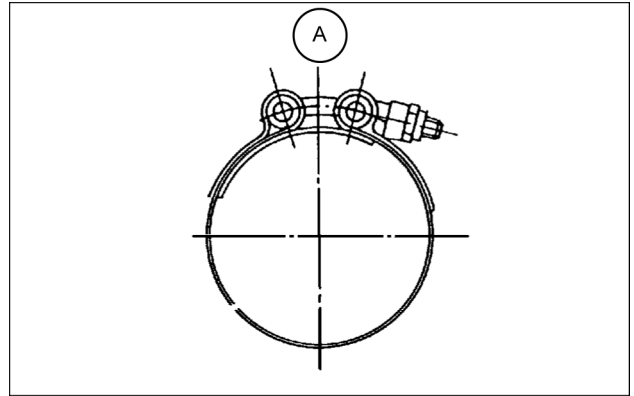

SMIL13CEX0159AA 15

A - T-Bolt Type

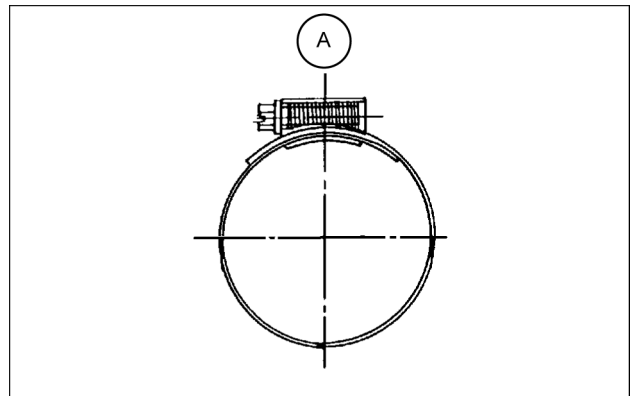

SMIL13CEX0160AA 16

A - Worm Gear Type

Connecting hose

- When replacing hoses, be sure to use only genuine parts. Using hoses other than genuine hoses may cause oil leakage, hose rupture or separation of fitting, possibly resulting in a fire on the machine.
- Do not install hoses kinked. Application of high oil pressure, vibration, or an impact to a kinked hose may result in oil leakage, hose rupture or separation of fitting.
Utilize print marks on hoses when installing hoses to prevent hose from being installed kinked.
- If hoses rub against each other, wear to the hoses will result, leading to hose rupture. Take necessary measures to protect hoses from rubbing against each other.
Take care that hoses do not come into contact with moving parts or sharp objects.

- A - WRONG
 B - RIGHT
 C - Rubbing Against Each Other

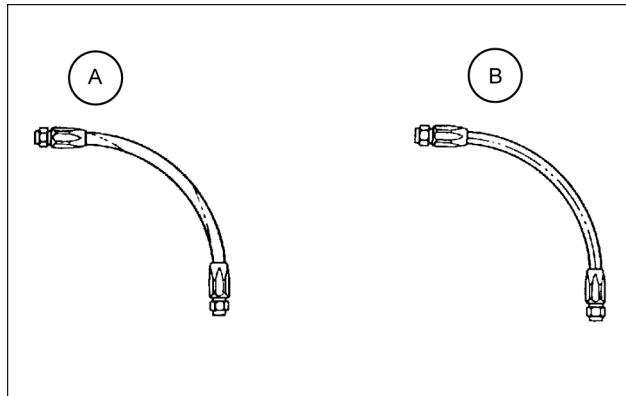

SMIL13CEX0161AA 17

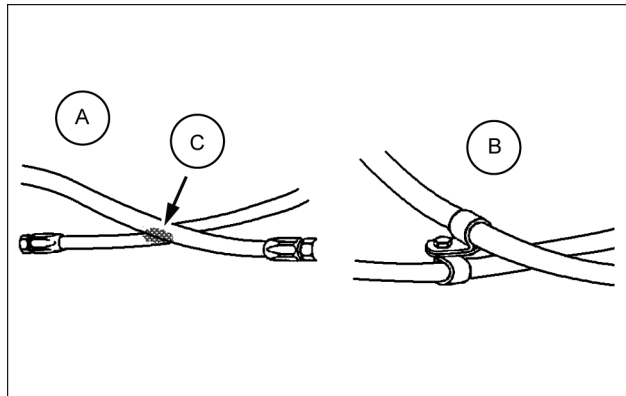

SMIL13CEX0162AB 18

- A - WRONG
 B - RIGHT
 C - Clamp
 D - Clamp
 E - Rubbing

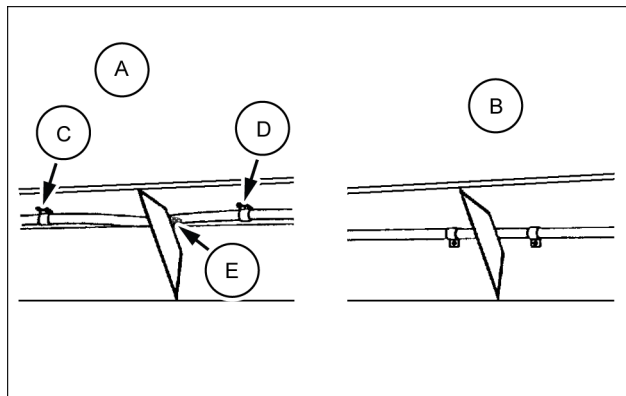

SMIL13CEX0163AB 19

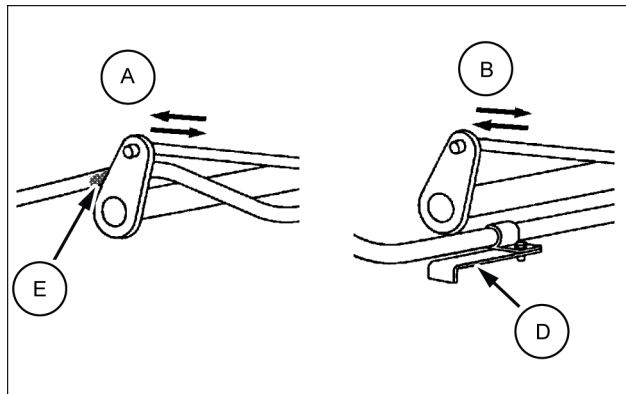

SMIL13CEX0164AB 20

Basic instructions - Shop and assembly

Shimming

For each adjustment operation, select adjusting shims and measure the adjusting shims individually using a micrometer, then add up the recorded values. Do not rely on measuring the entire shimming set, which may be incorrect, or the rated value shown on each shim.

Rotating shaft seals

For correct rotating shaft seal installation, proceed as follows:

1. Before assembly, allow the seal to soak in the oil it will be sealing for at least thirty minutes.
2. Thoroughly clean the shaft and check that the working surface on the shaft is not damaged.
3. Position the sealing lip facing the fluid.

NOTE: *With hydrodynamic lips, take into consideration the shaft rotation direction and position the grooves so that they will move the fluid towards the inner side of the seal.*

4. Coat the sealing lip with a thin layer of lubricant (use oil rather than grease). Fill the gap between the sealing lip and the dust lip on double lip seals with grease.
5. Insert the seal in its seat and press down using a flat punch or seal installation tool. Do not tap the seal with a hammer or mallet.
6. While you insert the seal, check that the seal is perpendicular to the seat. When the seal settles, make sure that the seal makes contact with the thrust element, if required.
7. To prevent damage to the seal lip on the shaft, position a protective guard during installation operations.

O-ring seals

Lubricate the O-ring seals before you insert them in the seats. This will prevent the O-ring seals from overturning and twisting, which would jeopardize sealing efficiency.

Sealing compounds

Apply a sealing compound on the mating surfaces when specified by the procedure. Before you apply the sealing compound, prepare the surfaces as directed by the product container.

Spare parts

Only use CNH Original Parts or CASE CONSTRUCTION Original Parts.

Only genuine spare parts guarantee the same quality, duration, and safety as original parts, as they are the same parts that are assembled during standard production. Only CNH Original Parts or CASE CONSTRUCTION Original Parts can offer this guarantee.

When ordering spare parts, always provide the following information:

- Machine model (commercial name) and Product Identification Number (PIN)
- Part number of the ordered part, which can be found in the parts catalog