

CX350D CX370D Crawler Excavator

SERVICE MANUAL

Part number 47899900

English

June 2015

Sample manual. Download All pages at:

<https://www.arespairmanual.com/downloads/2018-case-cx350d-cx370d-crawler-excavator-service-manual-51481238/>

© 2015 CNH Industrial Italia S.p.A. All Rights Reserved.

CASE
CONSTRUCTION

Product: 2018 Case CX350D CX370D Crawler Excavator Service Manual 51481238
Full Download: <https://www.arepairmanual.com/downloads/2018-case-cx350d-cx370d-crawler-excavator-service-manual-51481238/>



SERVICE MANUAL

CX350D Crawler excavators LC version (TIER4 FINAL) - MEA Market
CX370D Crawler excavators LC version (TIER4 FINAL) - MEA Market

Sample manual. Download All pages at:

<https://www.arepairmanual.com/downloads/2018-case-cx350d-cx370d-crawler-excavator-service-manual-51481238/>

47899900 26/06/2015

EN

Contents

INTRODUCTION

Engine.....	10
[10.001] Engine and crankcase	10.1
[10.102] Pan and covers	10.2
[10.106] Valve drive and gears	10.3
[10.101] Cylinder heads	10.4
[10.105] Connecting rods and pistons.....	10.5
[10.103] Crankshaft and flywheel.....	10.6
[10.216] Fuel tanks	10.7
[10.206] Fuel filters	10.8
[10.218] Fuel injection system.....	10.9
[10.202] Air cleaners and lines	10.10
[10.250] Turbocharger and lines.....	10.11
[10.254] Intake and exhaust manifolds and muffler	10.12
[10.500] Selective Catalytic Reduction (SCR) exhaust treatment.....	10.13
[10.501] Exhaust Gas Recirculation (EGR) - Diesel Particulate Filter (DPF) exhaust treatment	10.14
[10.400] Engine cooling system	10.15
[10.414] Fan and drive	10.16
[10.310] Aftercooler.....	10.17
[10.304] Engine lubrication system.....	10.18
Hydraulic systems.....	35
[35.000] Hydraulic systems.....	35.1
[35.300] Reservoir, cooler, and filters.....	35.2
[35.106] Variable displacement pump	35.3
[35.102] Pump control valves.....	35.4
[35.304] Combination pump units	35.5

[35.359] Main control valve	35.6
[35.357] Pilot system	35.7
[35.355] Hydraulic hand control	35.8
[35.356] Hydraulic foot control.....	35.9
[35.352] Hydraulic swing system	35.10
[35.353] Hydraulic travel system	35.11
[35.354] Hydraulic central joint	35.12
[35.736] Boom hydraulic system	35.13
[35.737] Dipper hydraulic system.....	35.14
[35.738] Excavator and backhoe bucket hydraulic system.....	35.15
[35.360] Hammer and rotating bucket hydraulic system	35.16
Frames and ballasting	39
[39.140] Ballasts and supports	39.1
Tracks and track suspension.....	48
[48.130] Track frame and driving wheels	48.1
[48.100] Tracks	48.2
[48.134] Track tension units	48.3
[48.138] Track rollers	48.4
Cab climate control	50
[50.100] Heating	50.1
[50.200] Air conditioning.....	50.2
Electrical systems	55
[55.000] Electrical system	55.1
[55.100] Harnesses and connectors.....	55.2
[55.525] Cab engine controls.....	55.3
[55.015] Engine control system.....	55.4
[55.201] Engine starting system	55.5
[55.301] Alternator.....	55.6

[55.302] Battery.....	55.7
[55.202] Cold start aid	55.8
[55.011] Fuel tank system	55.9
[55.010] Fuel injection system	55.10
[55.014] Engine intake and exhaust system.....	55.11
[55.988] Selective Catalytic Reduction (SCR) electrical system	55.12
[55.989] Exhaust Gas Recirculation (EGR) electrical system	55.13
[55.012] Engine cooling system	55.14
[55.013] Engine oil system	55.15
[55.640] Electronic modules	55.16
[55.512] Cab controls.....	55.17
[55.036] Hydraulic system control	55.18
[55.051] Cab Heating, Ventilation, and Air-Conditioning (HVAC) controls.....	55.19
[55.050] Heating, Ventilation, and Air-Conditioning (HVAC) control system.....	55.20
[55.524] Cab controls (Lift arm, Boom, Dipper, Bucket)	55.21
[55.416] Swing control system	55.22
[55.417] Travel control system	55.23
[55.530] Camera.....	55.24
[55.518] Wiper and washer system.....	55.25
[55.404] External lighting	55.26
[55.514] Cab lighting	55.27
[55.408] Warning indicators, alarms, and instruments	55.28
[55.992] Anti-theft system	55.29
[55.DTC] FAULT CODES.....	55.30
Booms, dippers, and buckets	84
[84.910] Boom	84.1
[84.912] Dipper arm	84.2
[84.100] Bucket.....	84.3
Platform, cab, bodywork, and decals	90

[90.150] Cab.....	90.1
[90.156] Cab glazing	90.2
[90.118] Protections and footboards.....	90.3
[90.120] Mechanically-adjusted operator seat.....	90.4
[90.100] Engine hood and panels	90.5



INTRODUCTION

Contents

INTRODUCTION

Foreword - Important notice regarding equipment servicing	3
Safety rules	4
Safety rules – General information	5
Safety rules – Personal safety	6
Safety rules – ROPS judgment	8
Torque – Bolt and nut	12
Torque – Special torque setting	13
Basic instructions - Shop and assembly	17
General specification (*)	19
General specification (*)	24
General specification – Main equipment	28
Weight (*)	37
Weight (*)	39
Dimension (*)	41
Dimension (*)	45
Conversion factors	48
Consumables	60
Capacities	63
Abbreviation	64
Product identification	67
Product identification - Machine orientation	70

(*) See content for specific models

Foreword - Important notice regarding equipment servicing

All repair and maintenance work listed in this manual must be carried out only by qualified dealership personnel, strictly complying with the instructions given, and using, whenever possible, the special tools.

Anyone who performs repair and maintenance operations without complying with the procedures provided herein shall be responsible for any subsequent damages.

The manufacturer and all the organizations of its distribution chain, including - without limitation - national, regional, or local dealers, reject any responsibility for damages caused by parts and/or components not approved by the manufacturer, including those used for the servicing or repair of the product manufactured or marketed by the manufacturer. In any case, no warranty is given or attributed on the product manufactured or marketed by the manufacturer in case of damages caused by parts and/or components not approved by the manufacturer.

The manufacturer reserves the right to make improvements in design and changes in specifications at any time without notice and without incurring any obligation to install them on units previously sold. Specifications, descriptions, and illustrative material herein are as accurate as known at time of publication but are subject to change without notice.

In case of questions, refer to your CASE CONSTRUCTION Sales and Service Networks.

Safety rules

Personal safety



This is the safety alert symbol. It is used to alert you to potential personal injury hazards. Obey all safety messages that follow this symbol to avoid possible death or injury.

Throughout this manual you will find the signal words DANGER, WARNING, and CAUTION followed by special instructions. These precautions are intended for the personal safety of you and those working with you.

Read and understand all the safety messages in this manual before you operate or service the machine.

 DANGER indicates a hazardous situation that, if not avoided, will result in death or serious injury.

 WARNING indicates a hazardous situation that, if not avoided, could result in death or serious injury.

 CAUTION indicates a hazardous situation that, if not avoided, could result in minor or moderate injury.

FAILURE TO FOLLOW DANGER, WARNING, AND CAUTION MESSAGES COULD RESULT IN DEATH OR SERIOUS INJURY.

Machine safety

NOTICE: Notice indicates a situation that, if not avoided, could result in machine or property damage.

Throughout this manual you will find the signal word Notice followed by special instructions to prevent machine or property damage. The word Notice is used to address practices not related to personal safety.

Information

NOTE: Note indicates additional information that clarifies steps, procedures, or other information in this manual.

Throughout this manual you will find the word Note followed by additional information about a step, procedure, or other information in the manual. The word Note is not intended to address personal safety or property damage.

Safety rules – General information

Cleaning

Clean the metal parts with cleaning solution that meets the standard and steam cleaning. (except for bearings)

After cleaning, dry well, and inject oil in all parts.

Also inject oil into the bearings after drying.

Inspection

When disassembling parts, check all the parts.

If there are any worn or damaged parts, replace them.

Inspect carefully to prevent initial breakdowns.

Bearing

Replace any loose bearings.

Air dry bearings before installing them.

Needle bearing

When inserting needle bearings, be very careful not to damage them.

Apply grease to the section where the needle bearing will be inserted.

Gear

Check that there is no wear and no damage.

Oil seal, O-ring, gasket

Always install new oil seals, O-rings, and gaskets.

Apply grease to sections where oil seals and O-rings will be inserted.

Shaft

Check that there is no wear and no damage.

Check the bearings and check for damaged oil seals on the shaft.

Service parts

Install CASE CONSTRUCTION genuine service parts.

When placing an order, check the parts catalog. It contains the CASE CONSTRUCTION genuine part numbers.

Any breakdowns arising from the installation of non-genuine parts are not covered by the warranty.

Lubricants (fuel, hydraulic oil)

Use the oil from the specified company or specified in the operator's manual or service Manual.

Any breakdowns arising from any fuel or hydraulic oil other than those specified are not covered by the warranty.

Safety rules – Personal safety

 **WARNING:**

This symbol indicates a precaution.
It gives information concerning the safety of the operator and those in the surroundings.
Read and understand these precautions thoroughly before performing the work.

Always comply with warnings and precautions so as to avoid any accidents.

This section covers information related to overall safety.

Check whether all warning labels are in place.

Additional labels can be ordered from Service Parts.

 **WARNING:**

Read the operator's manual to gain a thorough understanding of machine control operations.

 **WARNING:**

Perform any machine operations from the seating position.
Any other method may cause severe injuries.

 **WARNING:**

Only the one operator is to ride on the machine. No one else is to ride on it.

 **WARNING:**

Check the safety messages in the operator's manual before starting the engine.
Check all the warning labels on the machine.
Check that no one is within the machine's operating range.
Check the operating methods in a safe location before starting the actual work.
Understand the machine operations well, then operate in compliance with all service-related laws and regulations.
The operator's manual can be purchased at your CASE CONSTRUCTION dealer.

 **WARNING:**

Working with sloppy clothes or clothes with which safety cannot be ensured leads to damage to the machine and injury to the operator.
Always wear clothes that ensures safety.
In order to work more safely, it is recommended to wear additional safety equipment.
Helmet, safety shoes, ear protection, goggles, work clothes, and gloves

 **WARNING:**

Pay careful attention when working with the engine running.

 **WARNING:**

Check hydraulic equipment.
Work according to the procedure.
Do not change the procedure.

INTRODUCTION

 WARNING:

Check that there is no one in the surroundings before draining the pressure from hydraulic circuits during machine hydraulic cylinder inspection.

 WARNING:

Use gloves when handling high-temperature parts.

 WARNING:

Bring the lower parts or attachments in contact with the ground before inspecting or repairing them.

 WARNING:

Check that hoses and tubes are securely connected.
If there is any damage to a hose or tube, replace it.
Do not check for oil leaks by hand. Use cardboard or wood.

 WARNING:

When removing an attachment pin or other hardened pin, use a hammer that has a soft head.

 WARNING:

Wear eye protection when using a hammer to install a pin or when working with a grinder.
At this time, use goggles or eye protectors that meet standards.

 WARNING:

Park the machine in a safe location when repairing or inspecting it.

 WARNING:

Use work site protection when repairing the machine.
Check the oil, coolant, grease, and tools.
Recover materials and parts as necessary.
Pay enough attention to safety.

 WARNING:

Some of the machine's parts are extremely heavy.
Use an appropriate lifting equipment for such parts.
For weights and procedures, see the Service Manual.

 WARNING:

Exhaust gases are toxic.
Always provide good ventilation when working indoors or in any other enclosed space.

 WARNING:

If the electrolytic battery solution freezes, it may explode.

Safety rules – ROPS judgment

1. Purpose

Judge whether or not the model is compliant with ROPS by the ROPS criteria.

Compliance with ROPS is highly dependent on its deadweight and boom.

The model has passed the ROPS test for its deadweight with all selectable options installed (as of 2014).

However, the judgment is required because its deadweight or boom position may go beyond the assumption depending on derivative or order conditions.

2. ROPS criteria

Weight

For each class, the following weight shall not be exceeded.

If the weight is exceeded, a cab may become damaged in case of a rollover, causing the operator to die or become severely disabled.

It is not applicable beyond the criterion.

The ROPS-compliant model shall not exceed the weight shown in the table.

(The following weight is shown on the decal in the ROPS cab.)

Gross body weight	Class
20500 kg (45194.76 lb) or less	CX130D
	CX160D
	CX180D
32000 kg (70547.92 lb) or less	CX210D
	CX250D
	CX300D
40000 kg (88184.90 lb) or less	CX350D
	CX370D

Boom position

Warning

- If you make such modification as lowers the boom position, ROPS is not applicable.
- Consultation with us is required whenever it is assumed that the boom position is lowered by modification.
- The range of change in the boom position cannot be determined uniformly.

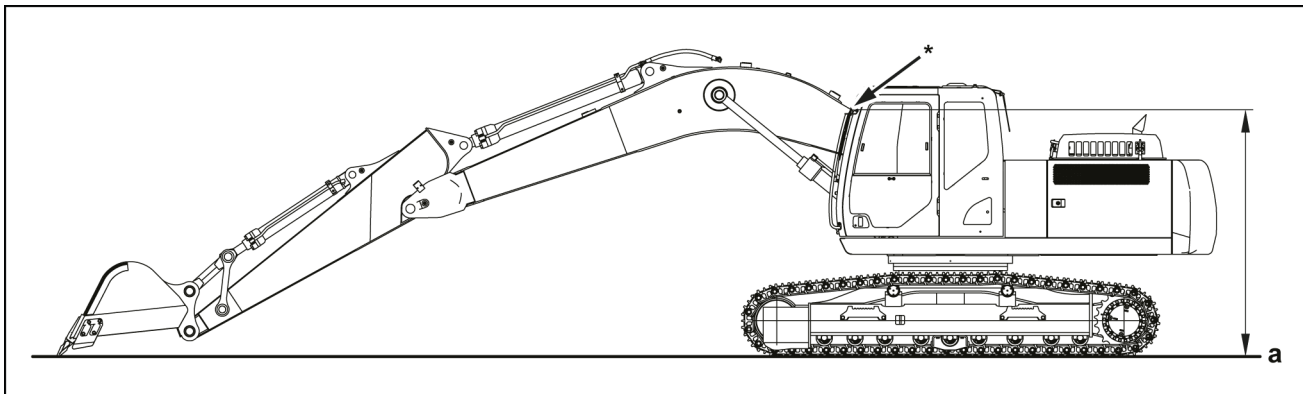

SMIL14CEX2001EA 1

(a) Ground point

It is not applicable if the position overlapping with a cab on the side view (mark * in the figure) is lowered significantly as compared with the standard model (standard arm), within the maximum digging radius with the bucket tip on the surface of the ground.

Moreover, it cannot be said that the 24-ton model, close to the limit weight, with a cab that can bear up to 31-tons and the 21-ton model with the same cab are the same in the degree of influence.

3. Prohibitions

- Such modification as reduces the strength of the platform where the ROPS cab is installed. (Such action or modification as reduces the function of the retaining anchor in the left rear of the cab)
- Such modification as affects the ROPS strength of the ROPS cab.

Modification prohibited (Red components)	All changes (grinding, welding, drilling, removal, etc.) are prohibited.
Conditional modification permitted (Gray components)	Removal of components is prohibited. Welding and drilling of bars (limited to 20 mm (0.79 in) or less in diameter) are allowed.

Cab (CX130D/CX160D/CX180D)

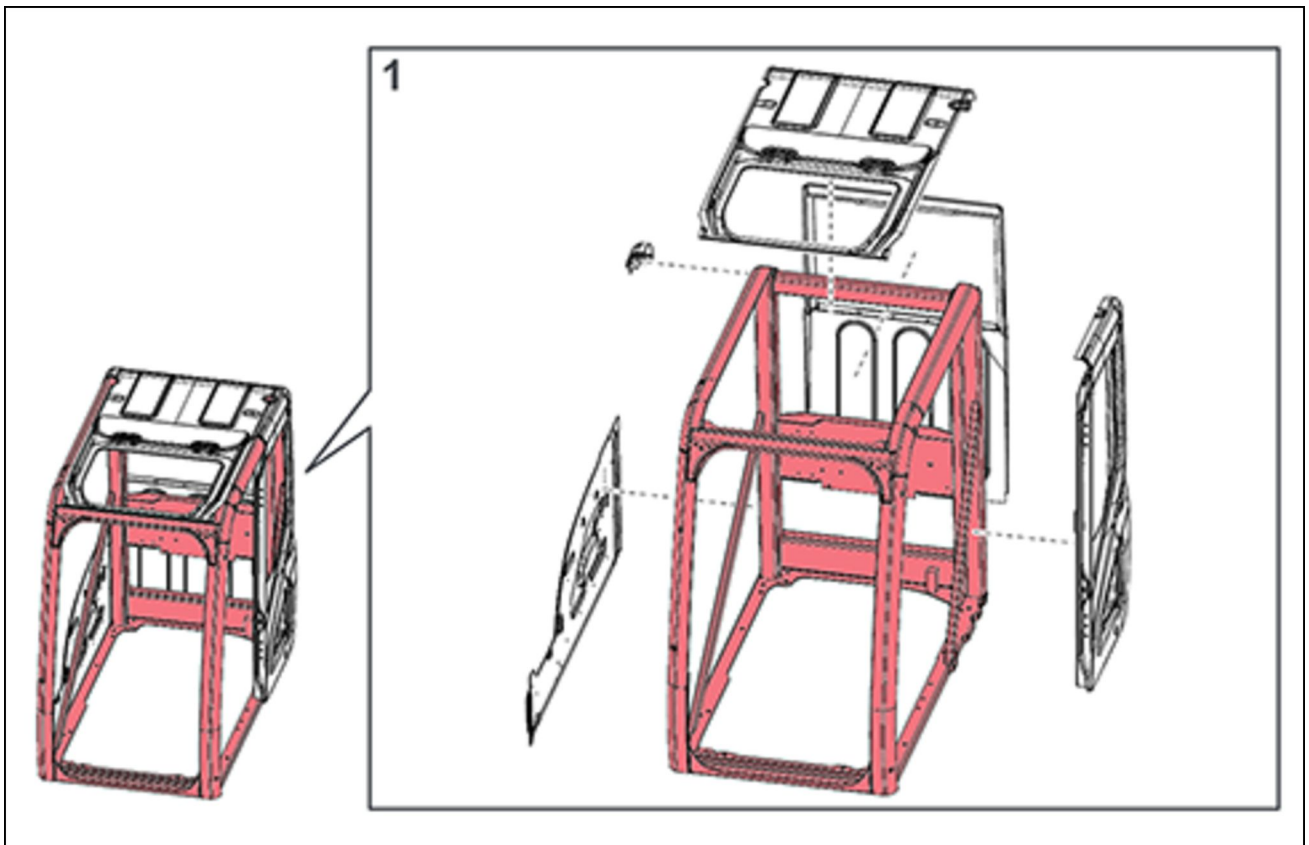

SMPH15CEX5805FA 2

Cab (CX210D/CX250D/CX300D)

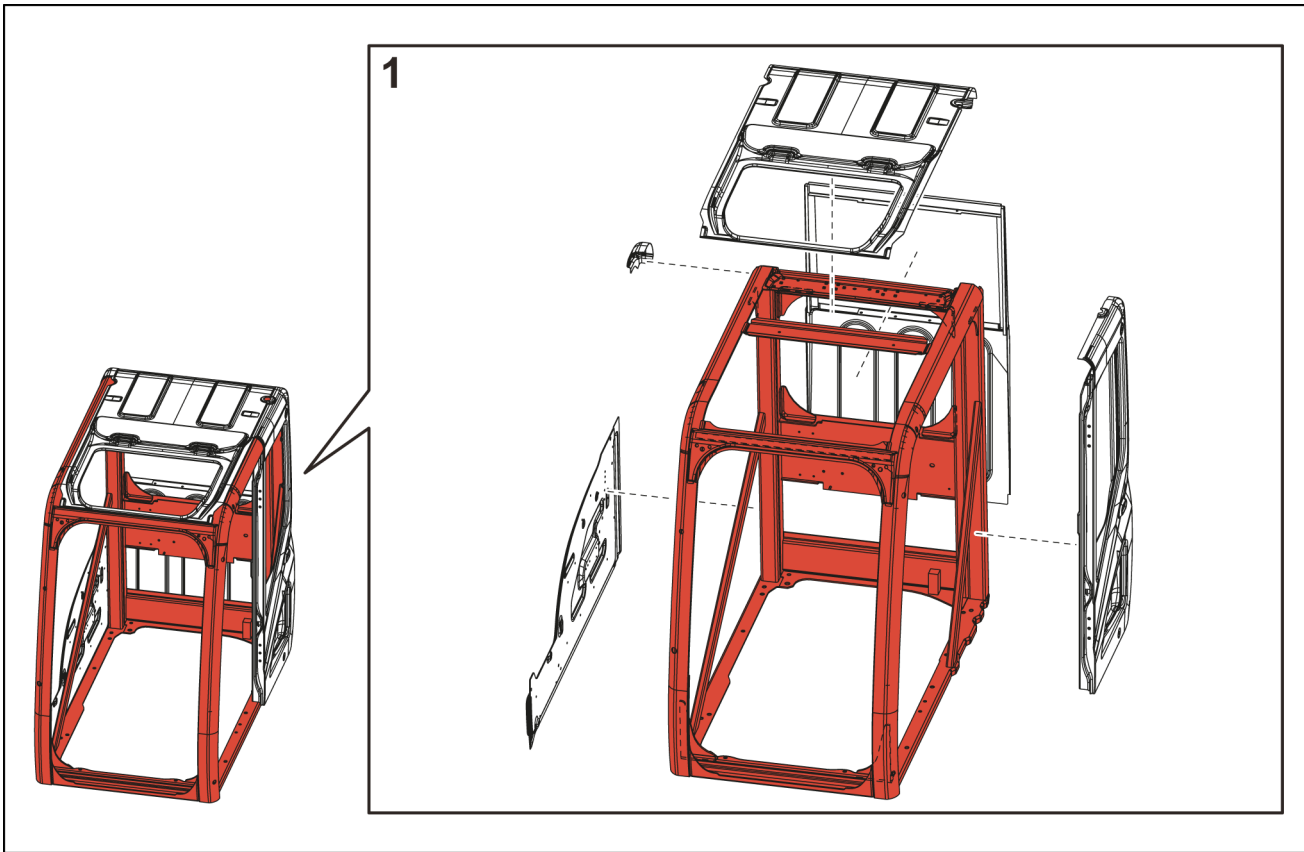

SMIL14CEX2002FA 3

Cab (CX350D/CX370D)

The large-sized model (CX350D/CX370D) cab consists of the medium-sized model (CX210D/CX250D/CX300D) cab in the figure plus seven reinforcements.

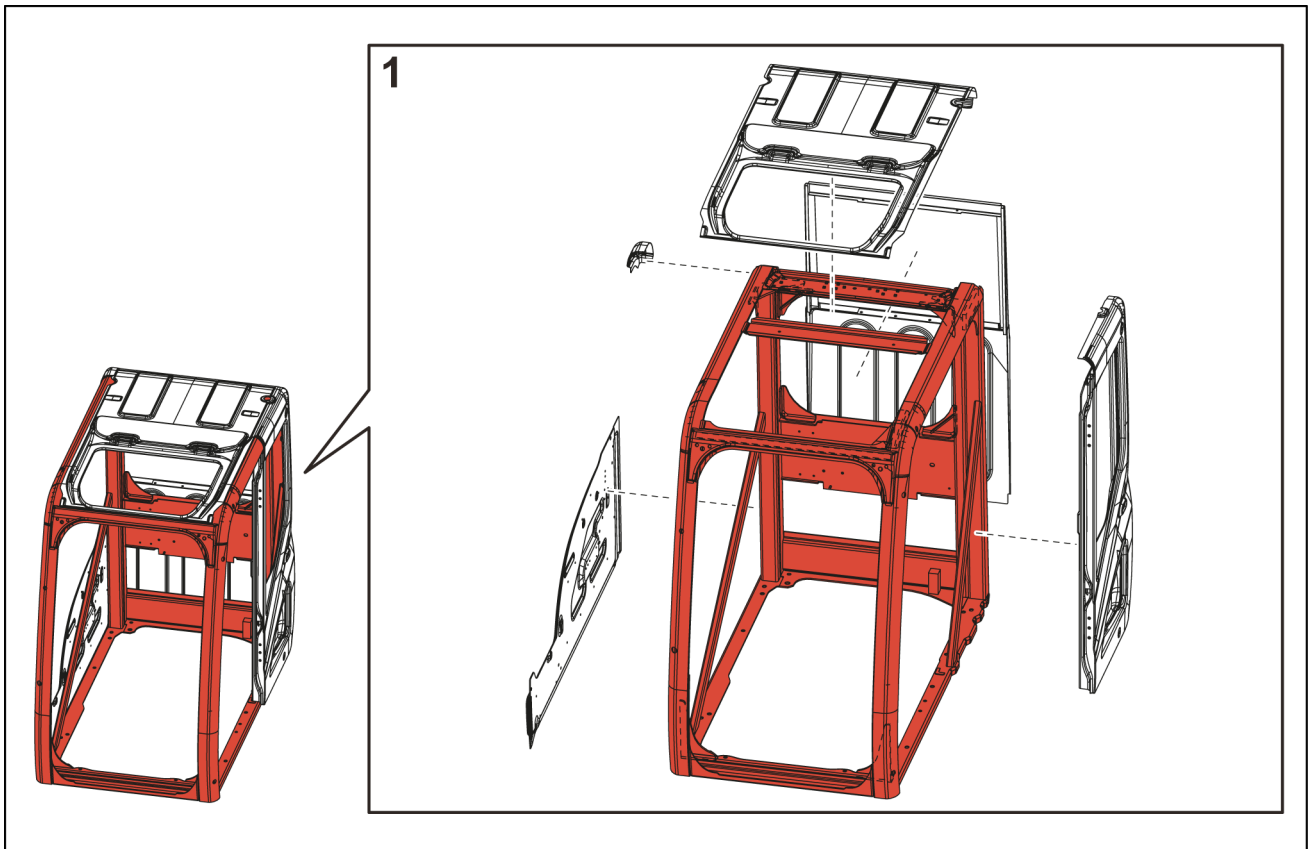

SMIL14CEX2003FA 4

The high cab is not supported basically. (Since it varies for each model, consultation with us is required in each case.)

Torque – Bolt and nut

- Tighten alternating between left and right and top and bottom so that uniform tightening force is applied.

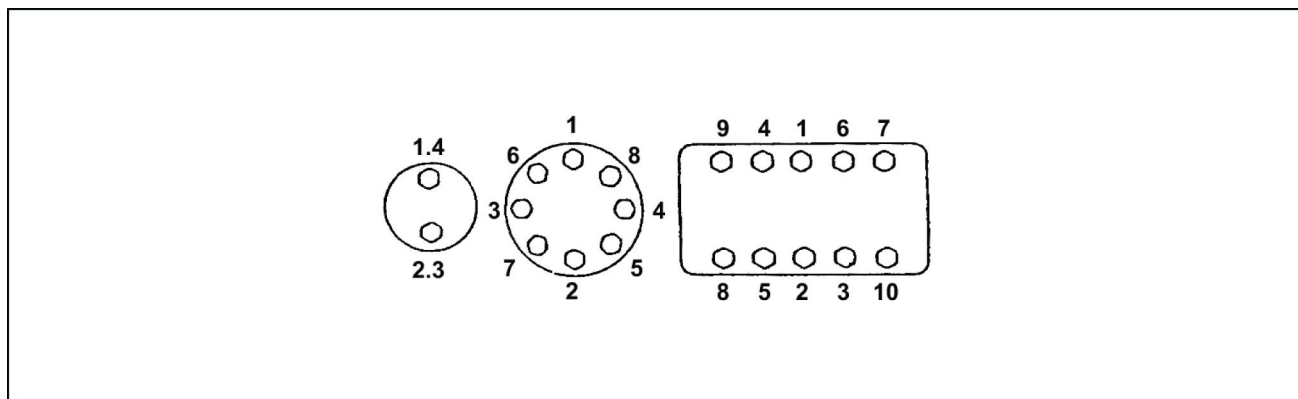

LPIL12CX00005EA 1

- If **LOCTITE®** was used on a removed bolt (there is something white sticking to the bolt when it is removed), clean the old **LOCTITE®** off with cleaning fluid, dry the bolt, then apply 2 - 3 drops of **LOCTITE®** to the thread section of the bolt.

Torque table

Bolt nominal diameter (size)		M6	M8	M10	M12	M14	M16	M18	M20
Hexagon bolt	Wrench	10 mm	13 mm	17 mm	19 mm	22 mm	24 mm	27 mm	30 mm
	Tightening torque	6.9 N·m (5.089 lb ft)	19.6 N·m (14.456 lb ft)	39.2 N·m (28.912 lb ft)	58.8 N·m (43.369 lb ft)	98.1 N·m (72.355 lb ft)	156.9 N·m (115.72 m (144.63 3 lb ft)	196.1 N·m (144.63 6 lb ft)	294.2 N·m (216.99 1 lb ft)
Hexagon socket head bolt	Wrench	5 mm	6 mm	8 mm	10 mm	12 mm	14 mm	14 mm	17 mm
	Tightening torque	8.8 N·m (6.491 lb ft)	21.6 N·m (15.931 lb ft)	42.1 N·m (31.051 lb ft)	78.5 N·m (57.899 lb ft)	117.7 N·m (86.811 lb ft)	176.5 N·m (130.18 0 lb ft)	245.2 N·m (180.85 0 lb ft)	343.2 N·m (253.13 1 lb ft)

Torque – Special torque setting

Code	Retightening location		Nominal bolt diameter	Wrench	Tightening torque
1*	Travel motor		M24	36 mm	900 - 1051 N·m (664 - 775 lb ft)
2*	Drive sprocket		M20	30 mm	521 - 608 N·m (384.27 - 448.44 lb ft)
3*	Take-up roller		M16	24 mm	267 - 312 N·m (196.93 - 230.12 lb ft)
4*	Upper roller		M20	30 mm	521 - 608 N·m (384.27 - 448.44 lb ft)
5*	Lower roller		M24	36 mm	902 - 1049 N·m (665 - 774 lb ft)
6*	Track guard		M24	36 mm	902 - 1049 N·m (665 - 774 lb ft)
7	Shoe		M24	32 mm	1236 - 1510 N·m (912 - 1114 lb ft)
8	Counterweight		M33	50 mm	1862 - 2058 N·m (1373.34 - 1517.90 lb ft)
9*	Turntable bearing		M24	36 mm	900 - 1050 N·m (664 - 774 lb ft)
10*	Swing unit		M24	36 mm	900 - 1050 N·m (664 - 774 lb ft)
11*	Engine	Mount	M20	30 mm	289 - 337 N·m (213 - 249 lb ft)
12*		Front bracket	M10	17 mm	64 - 73 N·m (47 - 54 lb ft)
13*		Rear bracket	M12	19 mm	109 - 127 N·m (80 - 94 lb ft)
14*	Radiator		M16	24 mm	147 - 176 N·m (108 - 130 lb ft)
15*	Hydraulic pump	Flange	M10	17 mm	64 - 73 N·m (47 - 54 lb ft)
16*		Pump	M20	17 mm hexagon socket head	367 - 496 N·m (270.69 - 365.83 lb ft)
17*	Hydraulic oil tank		M16	24 mm	233 - 276 N·m (172 - 204 lb ft)
18*	Fuel tank		M16	24 mm	233 - 276 N·m (172 - 204 lb ft)
19*	Control valve		M16	24 mm	267 - 312 N·m (196.93 - 230.12 lb ft)
20*	Center joint	Lock bar	M16	24 mm	267 - 312 N·m (196.93 - 230.12 lb ft)
21*		Joint	M12	19 mm	109 - 127 N·m (80.39 - 93.67 lb ft)
22	Cab		M16	24 mm	149 - 173 N·m (109.90 - 127.60 lb ft)
23	Battery		M10	17 mm	20 - 29 N·m (15 - 21 lb ft)

⚠ CAUTION:

- Make sure to apply **LOCTITE® 262™** or equivalent to the locations with the * mark, and tighten according to the specified torque.
- Tightening torque: $N \cdot m \div 9.8 = \text{kgf} \cdot m$

Tighten bolts and nuts that are not specified in the above table, as follows:

Nominal bolt diameter (Size)		M6	M8	M10	M12	M14	M16	M18	M20
Hexagon bolt	Wrench	10 mm	13 mm	17 mm	19 mm	22 mm	24 mm	27 mm	30 mm
	Tightening torque	6.9 N·m	19.6 N·m	39.2 N·m	58.8 N·m	98.1 N·m	156.9 N·m	196.1 N·m	294.2 N·m
Hexagon socket head bolt	Wrench	5 mm	6 mm	8 mm	10 mm	12 mm	14 mm	14 mm	17 mm
	Tightening torque	8.8 N·m	21.6 N·m	42.1 N·m	78.5 N·m	117.7 N·m	176.5 N·m	245.2 N·m	343.2 N·m

INTRODUCTION

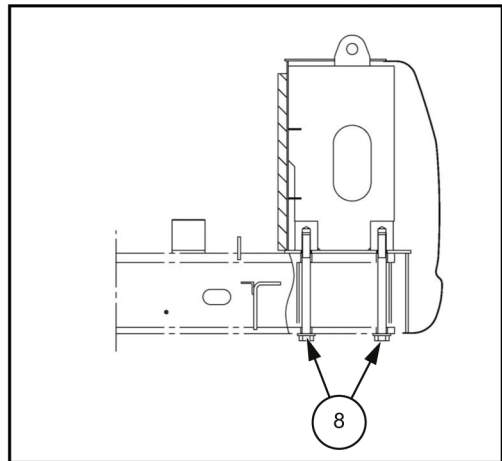
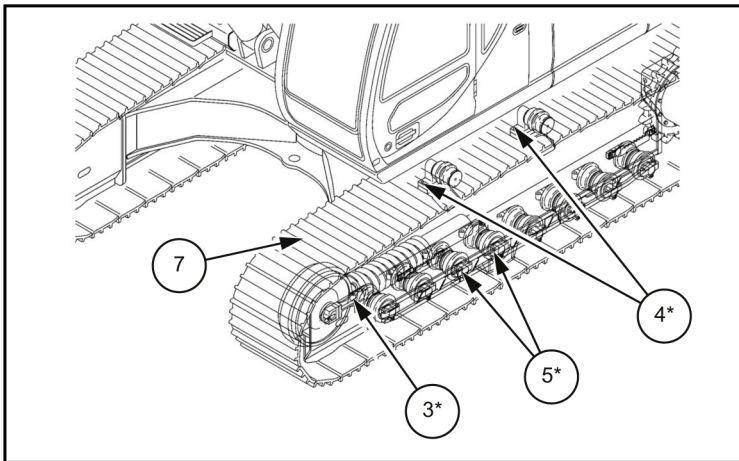
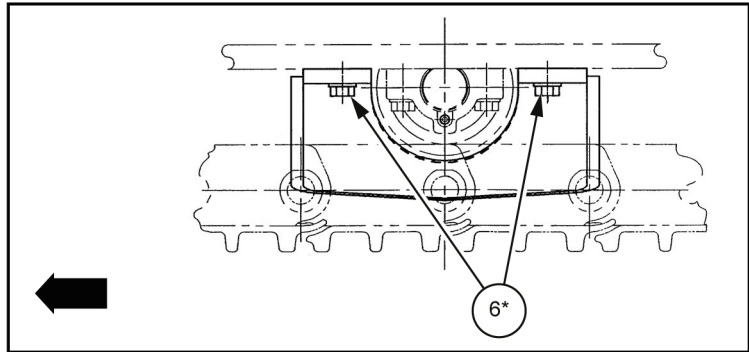
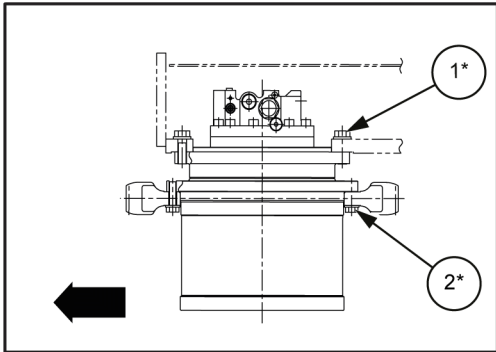
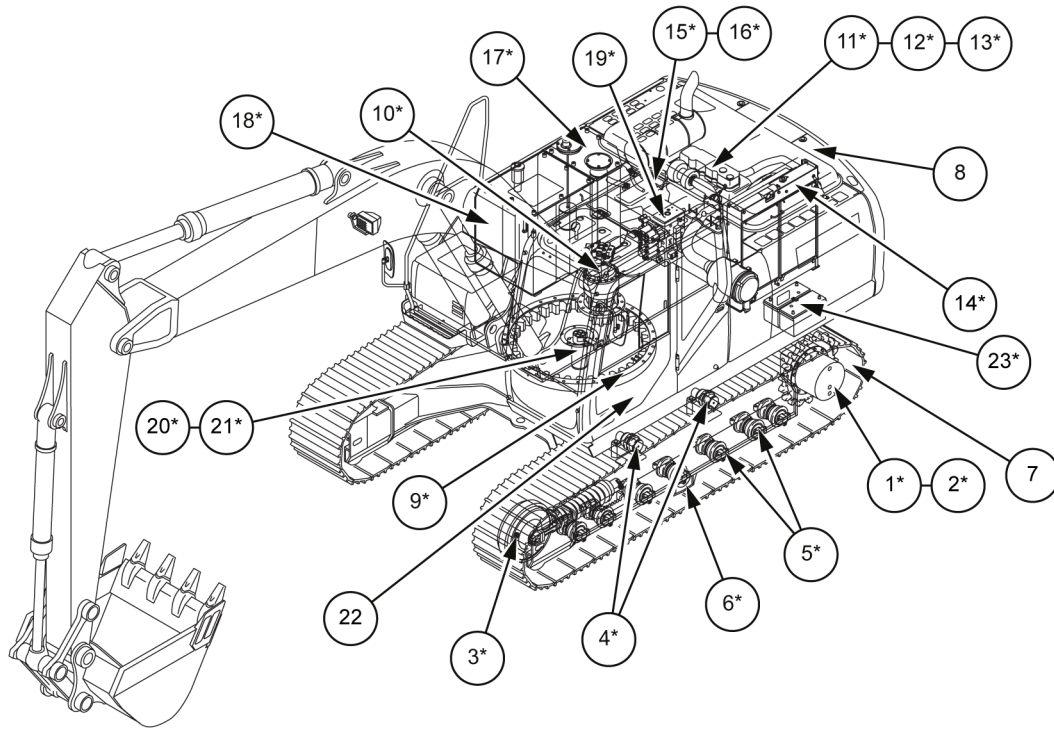

SMIL14CEX2929HB 1

INTRODUCTION

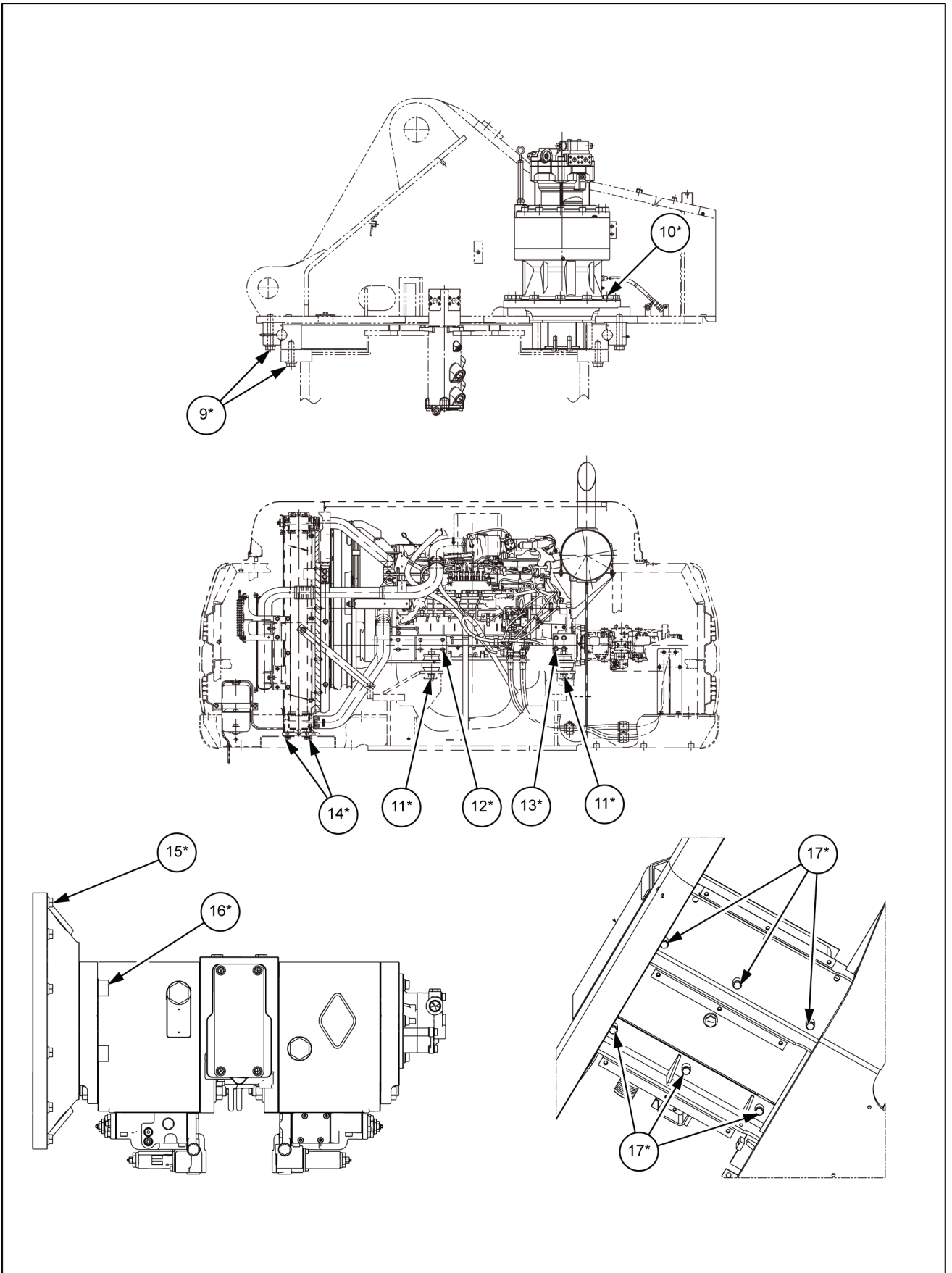

SML14CEX2930HB 2

INTRODUCTION

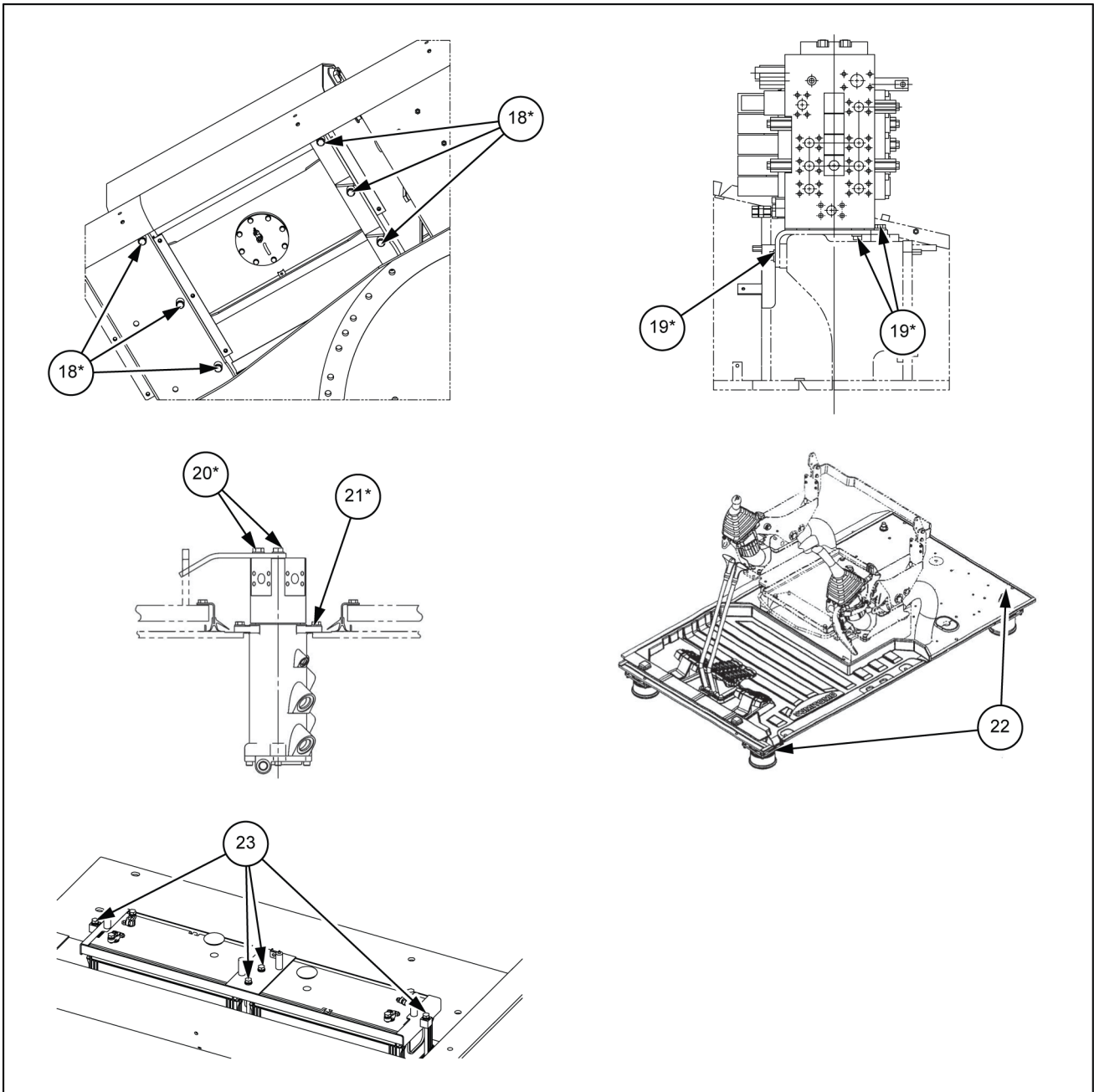

SMIL14CEX2931GB 3

Basic instructions - Shop and assembly

Shimming

For each adjustment operation, select adjusting shims and measure the adjusting shims individually using a micrometer, then add up the recorded values. Do not rely on measuring the entire shimming set, which may be incorrect, or the rated value shown on each shim.

Rotating shaft seals

For correct rotating shaft seal installation, proceed as follows:

1. Before assembly, allow the seal to soak in the oil it will be sealing for at least thirty minutes.
2. Thoroughly clean the shaft and check that the working surface on the shaft is not damaged.
3. Position the sealing lip facing the fluid.

NOTE: *With hydrodynamic lips, take into consideration the shaft rotation direction and position the grooves so that they will move the fluid towards the inner side of the seal.*

4. Coat the sealing lip with a thin layer of lubricant (use oil rather than grease). Fill the gap between the sealing lip and the dust lip on double lip seals with grease.
5. Insert the seal in its seat and press down using a flat punch or seal installation tool. Do not tap the seal with a hammer or mallet.
6. While you insert the seal, check that the seal is perpendicular to the seat. When the seal settles, make sure that the seal makes contact with the thrust element, if required.
7. To prevent damage to the seal lip on the shaft, position a protective guard during installation operations.

O-ring seals

Lubricate the O-ring seals before you insert them in the seats. This will prevent the O-ring seals from overturning and twisting, which would jeopardize sealing efficiency.

Sealing compounds

Apply a sealing compound on the mating surfaces when specified by the procedure. Before you apply the sealing compound, prepare the surfaces as directed by the product container.

Spare parts

Only use CNH Original Parts or CASE CONSTRUCTION Original Parts.

Only genuine spare parts guarantee the same quality, duration, and safety as original parts, as they are the same parts that are assembled during standard production. Only CNH Original Parts or CASE CONSTRUCTION Original Parts can offer this guarantee.

When ordering spare parts, always provide the following information:

- Machine model (commercial name) and Product Identification Number (PIN)
- Part number of the ordered part, which can be found in the parts catalog

Protecting the electronic and/or electrical systems during charging and welding

To avoid damage to the electronic and/or electrical systems, always observe the following practices:

1. Never make or break any of the charging circuit connections when the engine is running, including the battery connections.
2. Never short any of the charging components to ground.
3. Always disconnect the ground cable from the battery before arc welding on the machine or on any machine attachment.
 - Position the welder ground clamp as close to the welding area as possible.
 - If you weld in close proximity to a computer module, then you should remove the module from the machine.
 - Never allow welding cables to lie on, near, or across any electrical wiring or electronic component while you weld.
4. Always disconnect the negative cable from the battery when charging the battery in the machine with a battery charger.

NOTICE: *If you must weld on the unit, you must disconnect the battery ground cable from the machine battery. The electronic monitoring system and charging system will be damaged if this is not done.*

5. Remove the battery ground cable. Reconnect the cable when you complete welding.

⚠ WARNING

Battery acid causes burns. Batteries contain sulfuric acid.

Avoid contact with skin, eyes or clothing. Antidote (external): Flush with water. Antidote (eyes): flush with water for 15 minutes and seek medical attention immediately. Antidote (internal): Drink large quantities of water or milk. Do not induce vomiting. Seek medical attention immediately.

Failure to comply could result in death or serious injury.

W0111A

Special tools

The special tools that CASE CONSTRUCTION suggests and illustrate in this manual have been specifically researched and designed for use with CASE CONSTRUCTION machines. The special tools are essential for reliable repair operations. The special tools are accurately built and rigorously tested to offer efficient and long-lasting operation.

By using these tools, repair personnel will benefit from:

- Operating in optimal technical conditions
- Obtaining the best results
- Saving time and effort
- Working in safe conditions

General specification

CX350D Crawler excavators LC version (TIER4 FINAL) - MEA Market	MEA
---	-----

Engine

Type	Water-cooled, 4-cycle diesel, 6-cylinder in line, High pressure common rail system (electric control), Turbocharger with air cooled intercooler, SCR system	
Model	ISUZU AQ-6HK1X	
Rated flywheel horse power		
	ISO 9249	200 kW (272 Hp) at 1900 RPM
	ISO 14396	210 kW (286 Hp) at 1900 RPM
Piston displacement	7790 cm³ (475 in³)	
Maximum torque		
	ISO 9249	988 N·m (729 lb ft) at 1500 RPM
	ISO 14396	1020 N·m (752 lb ft) at 1500 RPM
Bore and stroke	115 - 125 mm (4.53 - 4.92 in)	
Voltage	24 V	
Alternator	50 A	
Starter	24 V 5.0 kW	

Hydraulic system

Main pumps	2 variable displacement axial piston pumps with regulating system	
	Max. oil flow	2 × 300.0 L (79.3 US gal) at 1900 RPM
	Working circuit pressure	Boom/Arm/Bucket 34.3 MPa (4975 psi)
		Swing circuit 37.3 MPa (5410 psi) with auto power up
		Travel circuit 30.4 MPa (4410 psi)
		34.3 MPa (4975 psi)
Pilot pump	1 gear pump	
	Max. oil flow	28.5 L (7.5 US gal)
	Working circuit pressure	3.9 MPa (566 psi)
Control valves	With Boom/Arm holding valve	
	One 4-spool valve for Right track travel, Bucket, Boom and Arm acceleration	
	One 5-spool valve for Left track travel, Auxiliary, Swing, Boom acceleration and Arm	
Swing device		
	Motor	Fixed displacement axial piston motor
	Brake	Mechanical disc brake
	Final drive	Planetary gear reduction
	Turn table bearing	Ball bearing type with internal gear
	Maximum swing speed	9.7 RPM
	Swing torque	112.000 N·m (82.607 lb ft)
Cylinders	NO. of cylinders – bore X Rod diameter X Stroke	
	Boom	2 x Ø 145 mm (5.709 in) - Ø 100 mm (3.937 in) - 1495 mm (58.858 in)
	Arm	1 x Ø 170 mm (6.693 in) - Ø 120 mm (4.724 in) - 1748 mm (68.819 in)
	Bucket	1 x Ø 150 mm (5.906 in) - Ø 105 mm (4.134 in) - 1210 mm (47.638 in)
Cooling system		
	Fan	Ø 850 mm (33.5 in) with 6-blades
	Radiator capacity	85.7 kW (73,700 kcal/h)
		fin type Corrugated fin (wavy type)
		fin space 1.75 mm (0.06890 in)
	Long life coolant	Coolant 55 % , Water 45 %

INTRODUCTION

Oil cooler capacity		52.9 kW (45,500 kcal/h)
	fin type	Corrugated fin (wavy type)
	fin space	1.75 mm (0.06890 in)
Intercooler capacity		25.7 kW (22,100 kcal/h)
	fin type	Corrugated fin (wavy type)
	fin space	2.5 mm (0.0984 in)
Fuel cooler capacity		1.7 kW (1,410 kcal/h)
	fin type	Corrugated fin (wavy type)
	fin space	2.0 mm (0.0787 in)
Filters		
	Suction filter	105 µm
	Return filter	6 µm
	Pilot line filter	8 µm

Hydraulic controls

Boom/Arm/Bucket/Swing	Pilot pressure control system (ISO control pattern)
Travel	Pilot pressure control system
Work mode select	SP - mode
	H - mode
	Auto - mode
Travel mode select	2-speed travel
Attachment cushion control	
Hydraulic lock (gate lock, left side tilt console)	

Electrical system

Engine control		
	Dial type throttle control	
	One touch idle / Auto deceleration / Auto idle shutdown system	
	Emergency stop	
Monitor system		
	Message display (Caution, condition, etc.)	
	Work mode display (SP, H, Auto)	
	Machine condition (Power boost, etc.)	
	Alarm display and buzzer	
	Water temperature	
	Hydraulic oil temperature	
	Fuel level	
	Diagnosis system	
	Rear view camera image	
	Urea water level	
Wire harness		
	Waterproof type connector	
Safety		
	Travel alarm	
	Double horn	
Battery	2 X 12 V 128 A·h/5HR	
Lights		
Working light	Upper	24 V 70 W X 1
	Boom	24 V 70 W X 1
	Cab	24 V 70 W X 2
Operator's cab room		24 V 70 W X 1

Operator environment

Operator's cab		
	Smooth and round shape design cab, fabricated by press work	
	Safety glass for all windows	
	Shock-less cab suspension by 4-point fluid mounting	
	Sliding front window with auto lock	
	Built-in type full-color LCD monitor display	
	Membrane switch on monitor display	
	Windshield wiper & washer	
	Floor mat	
	Polycarbonate roof hatch & Sun shade	
	Auto air-conditioner	
	Rain deflector	
	Sun visor	
	Roll-over protective structure (ROPS)	
	Top guard OPG level 1 (in CAB structure)	
	Top guard OPG level 2 (additional guard)	
Operator's seat		
	Low frequency air suspension with air springs and double acting hydraulic damper. (Achieves ISO7096 in category EM6)	
	With following features	
	Manual weight adjustment	Backrest angle adjustment
	Seat height adjustment	Adjustable pivoting armrests linked to consoles
	Adjustable headrest	Retractable seat belt
	Adjustable lumbar support	Control consoles adjust independently of seat
Others		
	Rear view mirror (Cab side & Right side)	
	Rear view Camera	

Undercarriage

Travel motor	Variable displacement axial piston motor	
Brake	Mechanical disc brake	
Hydraulic service brake	Brake valve	
Final drive	Planetary gear reduction	
Travel speeds	High	5.5 km/h (3.4 mph) (Automatic travel speed shifting)
	Low	3.3 km/h (2.1 mph)
Drawbar pull	273 kN (61373 lb)	
Number of carrier rollers (each side)	2	
Number of track rollers (each side)	8	
Number of shoes (each side)	48	
Type of shoe	Triple grouser shoe	
Link pitch	216 mm (8.504 in)	
Width of shoe	600 mm (23.622 in) (S.T.D)	
Grade-ability	70 % (35 °)	

Mass

Operating mass	35800 kg (78925.49 lb)
	with 3.25 m (10.6627 ft) Arm, 1.4 m ³ Bucket, 600 mm (23.622 in) grouser shoe, operator, lubricant, coolant and full fuel tank
Shipping mass	34100 kg (75177.63 lb)
	Operating mass - (operator mass [75 kg (165.35 lb)] + 90 % of fuel mass [440 kg (970.03 lb)]+ bucket mass [1180 kg (2601.45 lb)])
Counter weight mass	6400 kg (14109.58 lb)

INTRODUCTION

Ground pressure	0.067 MPa (9.718 psi)
with 3.25 m (10.6627 ft) Arm, 1.4 m³ Bucket, 600 mm (23.622 in) grouser shoe	

Digging force (with 1.4 m³ bucket) (ISO 6015)

	3.25 m (10.6627 ft) Arm	2.21 m (7.2507 ft) Arm	2.63 m (8.6286 ft) Arm	4.04 m (13.2546 ft) Arm
Arm digging force	164.5 kN (36981.1 lb)	225.3 kN (50649.5 lb)	194.7 kN (43770.3 lb)	140.0 kN (31473.3 lb)
With auto power up	178.8 kN (40195.8 lb)	245.0 kN (55078.2 lb)	211.7 kN (47592.1 lb)	152.2 kN (34215.9 lb)
Bucket digging force	229.7 kN (51638.6 lb)	229.7 kN (51638.6 lb)	229.7 kN (51638.6 lb)	229.7 kN (51638.6 lb)
With auto power up	249.8 kN (56157.3 lb)	249.8 kN (56157.3 lb)	249.8 kN (56157.3 lb)	249.8 kN (56157.3 lb)

Dimensions

	3.25 m (10.6627 ft) Arm	2.21 m (7.2507 ft) Arm	2.63 m (8.6286 ft) Arm	4.04 m (13.2546 ft) Arm
Overall length (without attachment)	6010 mm (236.614 in)	6010 mm (236.614 in)	6010 mm (236.614 in)	6010 mm (236.614 in)
Overall length (with attachment)	11170 mm (439.764 in)	11250 mm (442.913 in)	11220 mm (441.732 in)	11190 mm (440.551 in)
Overall height (to top of boom)	3470 mm (136.614 in)	3620 mm (142.520 in)	3630 mm (142.913 in)	3620 mm (142.520 in)
Overall height (to top of Cab)	3260 mm (128.346 in)	3260 mm (128.346 in)	3260 mm (128.346 in)	3260 mm (128.346 in)
Overall height (to top of guardrail)	3470 mm (136.614 in)	3470 mm (136.614 in)	3470 mm (136.614 in)	3470 mm (136.614 in)
Upper structure overall width	3030 mm (119.291 in)	3030 mm (119.291 in)	3030 mm (119.291 in)	3030 mm (119.291 in)
Swing (rear end) radius	3550 mm (139.764 in)	3550 mm (139.764 in)	3550 mm (139.764 in)	3550 mm (139.764 in)
Clearance height under upper structure	1210 mm (47.638 in)	1210 mm (47.638 in)	1210 mm (47.638 in)	1210 mm (47.638 in)
Minimum ground clearance	470 mm (18.504 in)	470 mm (18.504 in)	470 mm (18.504 in)	470 mm (18.504 in)
Wheel base (Center to center of wheels)	4040 mm (159.055 in)	4040 mm (159.055 in)	4040 mm (159.055 in)	4040 mm (159.055 in)
Crawler overall length	4980 mm (196.063 in)	4980 mm (196.063 in)	4980 mm (196.063 in)	4980 mm (196.063 in)
Track gauge	2600 mm (102.362 in)	2600 mm (102.362 in)	2600 mm (102.362 in)	2600 mm (102.362 in)
Undercarriage overall width [with 600 mm (23.622 in) shoes]	3200 mm (125.984 in)	3200 mm (125.984 in)	3200 mm (125.984 in)	3200 mm (125.984 in)
Crawler tracks height	1090 mm (42.913 in)	1090 mm (42.913 in)	1090 mm (42.913 in)	1090 mm (42.913 in)

Working ranges

	3.25 m (10.6627 ft) Arm	2.21 m (7.2507 ft) Arm	2.63 m (8.6286 ft) Arm	4.04 m (13.2546 ft) Arm
Boom length	6450 mm (253.937 in)	6450 mm (253.937 in)	6450 mm (253.937 in)	6450 mm (253.937 in)
Bucket radius	1680 mm (66.142 in)	1680 mm (66.142 in)	1680 mm (66.142 in)	1680 mm (66.142 in)
Bucket wrist action	173 °	173 °	173 °	173 °
Maximum reach at GRP	10980 mm (432.283 in)	9970 mm (392.520 in)	10450 mm (411.417 in)	11710 mm (461.024 in)
Maximum reach	11170 mm (439.764 in)	10180 mm (400.787 in)	10650 mm (419.291 in)	11900 mm (468.504 in)

INTRODUCTION

Product: 2018 Case CX350D CX370D Crawler Excavator Service Manual 51481238

Full Download: <https://www.arepairmanual.com/downloads/2018-case-cx350d-cx370d-crawler-excavator-service-manual-51481238/>

~~70d-crawler-excavator-service-manual-51481238/~~

Max. digging depth	7340 mm (288.976 in)	6300 mm (248.031 in)	6720 mm (264.567 in)	8140 mm (320.472 in)
Max. digging height	10380 mm (408.661 in)	9830 mm (387.008 in)	10280 mm (404.724 in)	10650 mm (419.291 in)
Max. dumping height	7240 mm (285.039 in)	6730 mm (264.961 in)	7110 mm (279.921 in)	7530 mm (296.457 in)

Sample manual. Download All pages at:

<https://www.arepairmanual.com/downloads/2018-case-cx350d-cx370d-crawler-excavator-service-manual-51481238/>