

Accessories and Body, Cab

Body Collision Repair

00 - GENERAL, TECHNICAL DATA

VEHICLE IDENTIFICATION

Type plate / Vehicle Identification Number (VIN)

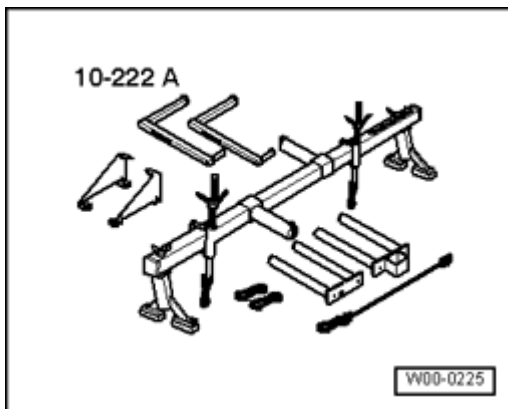
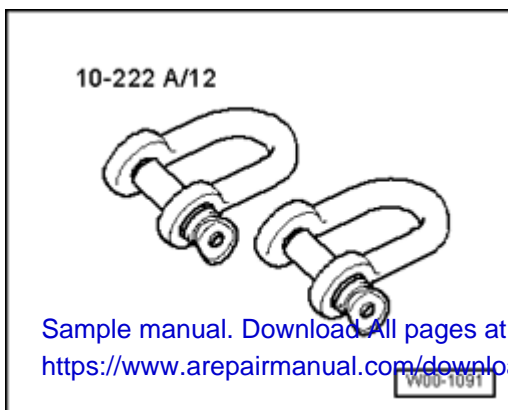

Fig. 1: Type Plate / Vehicle Identification Number (VIN)
 Courtesy of VOLKSWAGEN UNITED STATES, INC.

The vehicle identification number - **A** - (VIN) is stamped on the engine compartment bulkhead. It is visible via a window in the plenum chamber cover.

Type plate - **B** - is attached to the plenum chamber behind the right strut tower.

Vehicle data label



Sample manual. Download All pages at:
<https://www.arepairmanual.com/downloads/2006-audi-tt-car-service-repair-workshop-manual/>

Fig. 2: Identifying Vehicle Data Sticker

Courtesy of VOLKSWAGEN UNITED STATES, INC.

The vehicle data label is located in the spare wheel well at the rear of the vehicle.

BODY DIMENSIONS

Floor group, front

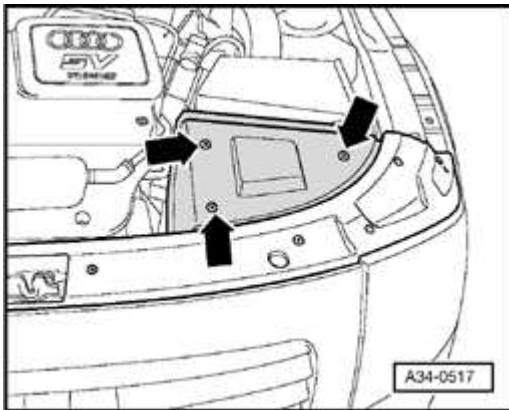

Fig. 3: Body Dimensions - Floor Group, Front
Courtesy of VOLKSWAGEN UNITED STATES, INC.

Distance between front attachment points of front suspension

a - 956 2mm

Diagonal distance between front longmember and mounting points of front axle

b - 949 2mm

Distance between front mounting points of front axle

c - 753 2mm

Diagonal distance between mounting points of front axle

d - 772 2mm

Sample manual. Download All pages at:
<https://www.repairmanual.com/downloads/2006-audi-tt-car-service-repair-workshop-manual/>

Distance between rear mounting points of front axle

e - 610 2mm

Floor group, center

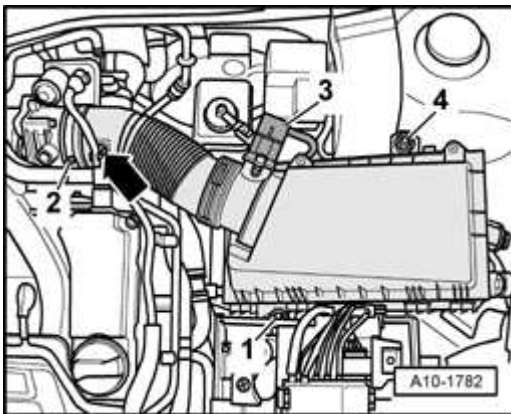

Fig. 4: Body Dimensions - Floor Group, Center
Courtesy of VOLKSWAGEN UNITED STATES, INC.

Diagonal distance between rear mounting points of front suspension and rear axle mount

f - 1620 2mm

Diagonal distance between rear mounting points of front suspension and rear axle mount

g - 1360 2mm

Distance between axle mounts

h - 1360 2mm

Distance between rear sections of front longmembers

j - 830 2mm

Floor group, rear

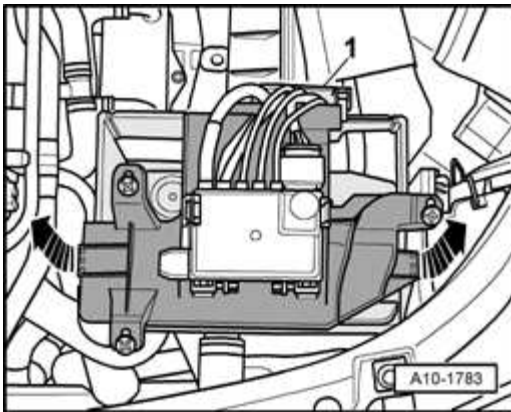

Fig. 5: Body Dimensions - Floor Group, Rear
Courtesy of VOLKSWAGEN UNITED STATES, INC.

Distance between axle mounts

k - 1270 2mm

Diagonal distance between axle mount and longmember

l - 1753 2mm

Diagonal distance between rear mounting point of rear axle and rear longmember

m - 1853 2mm

Diagonal distance between factory mounting point and longmember

n - 962 2mm

Body, front

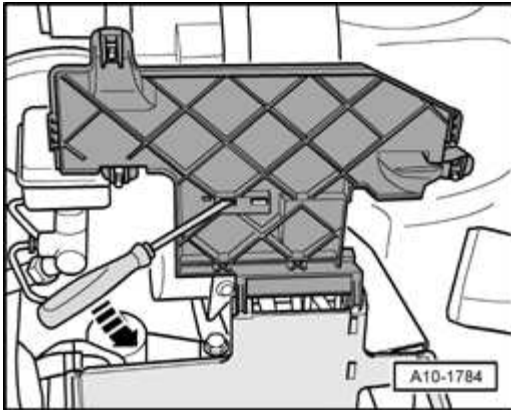

Fig. 6: Body Dimensions - Body, Front (1 Of 2)
Courtesy of VOLKSWAGEN UNITED STATES, INC.

Distance between front longmembers

a -867 2mm

Distance between fender mounts at rear

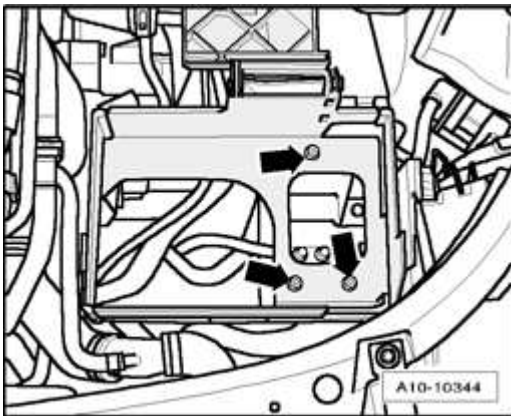

Fig. 7: Body Dimensions - Body, Front (2 Of 2)
Courtesy of VOLKSWAGEN UNITED STATES, INC.

b -1480 2mm

Distance between fender mounts

c -1360 2mm

Diagonal distance between fender mounts and strut tower mounts

d -1320 2mm

Distance between strut tower mounts

e -1130 2mm

Body, center

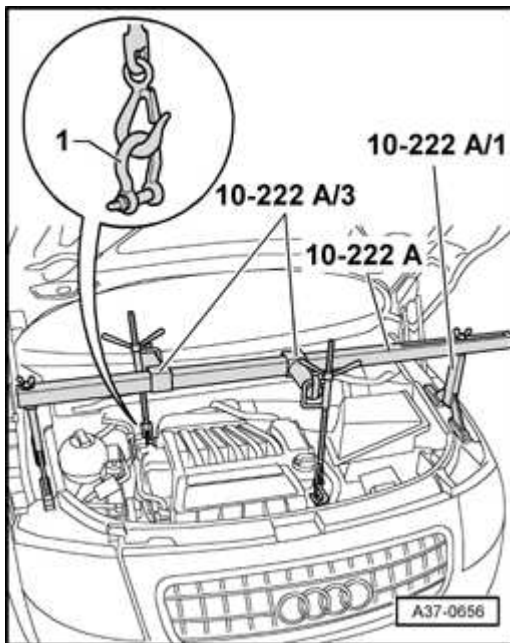

Fig. 8: Body Dimensions - Body, Center

Courtesy of VOLKSWAGEN UNITED STATES, INC.

Distance between A-pillars

f -1400 2mm

Distance between A-pillar and B-pillar

g -1100 2mm

Distance between B-pillars

h -1320 2mm

Height of door opening

j -870 2mm

Body, center (Roadster)

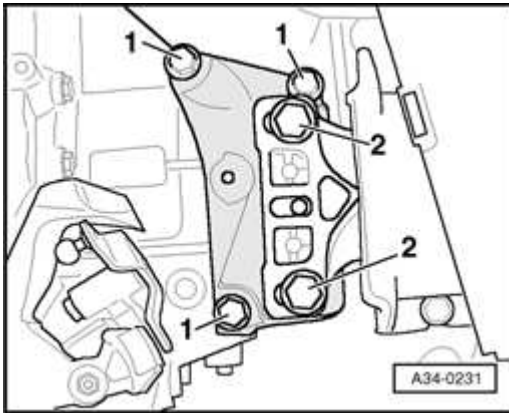

Fig. 9: Body Dimensions - Body, Center (Roadster)
Courtesy of VOLKSWAGEN UNITED STATES, INC.

Distance between A-pillar and B-pillar

p - 777 2mm

Body, rear

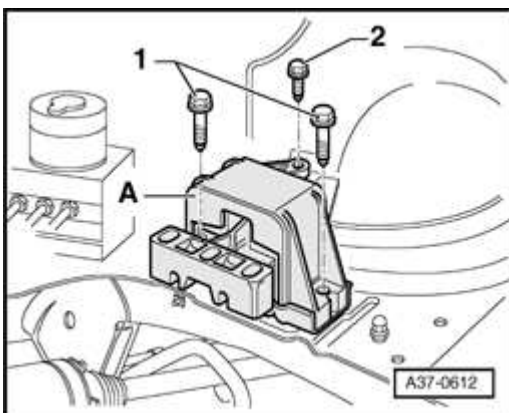

Fig. 10: Body Dimensions - Body, Rear (1 Of 2)
Courtesy of VOLKSWAGEN UNITED STATES, INC.

Distance between rear longmembers

k -1048 2mm

2006 Audi TT

Accessories and Body, Cab Body Collision Repair

Distance between cross panel to window crossmember

l -1245 2mm

Distance between tail light mounts

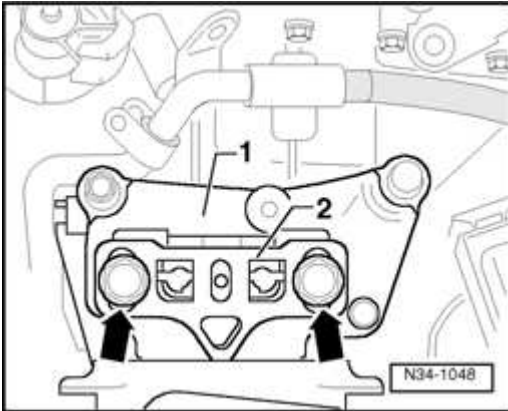

Fig. 11: Body Dimensions - Body, Rear (2 Of 2)
Courtesy of VOLKSWAGEN UNITED STATES, INC.

m -1080 2mm

Distance between lower side panels

n -995 2mm

Distance between upper side panels

o - 1068 2mm

Body, rear (Roadster)

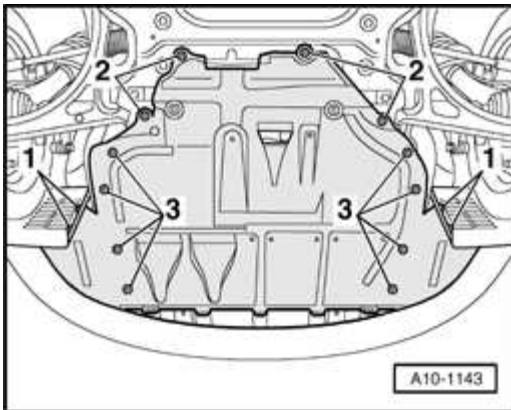

Fig. 12: Body Dimensions - Body, Rear (Roadster) (1 Of 2)
Courtesy of VOLKSWAGEN UNITED STATES, INC.

Distance between lower side panels

q - 992 2mm

Distance between upper side panels

r - 1050 2mm

Distance between mounting points of gas-filled struts

s - 988 2mm

Trunk opening height

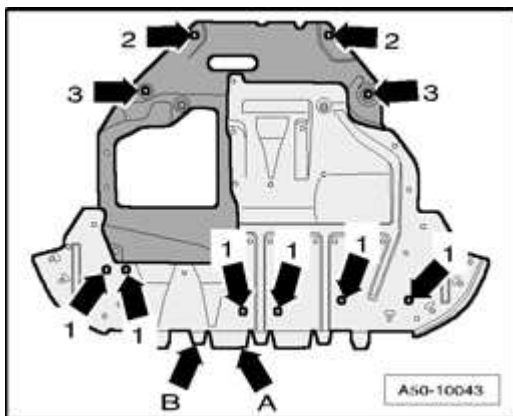

Fig. 13: Body Dimensions - Body, Rear (Roadster) (2 Of 2)
Courtesy of VOLKSWAGEN UNITED STATES, INC.

t - 538 2mm

BODY PANEL GAPS

Body, front

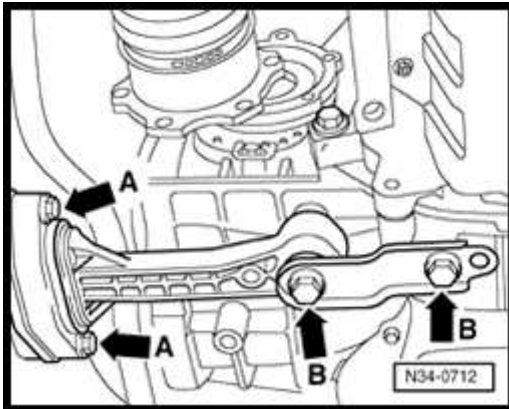

Fig. 14: Body Panel Gaps - Body, Front
Courtesy of VOLKSWAGEN UNITED STATES, INC.

3371 adjustment gauge is used to check or adjust gaps.

C 1.5 mm

F 3.0 mm

H 4.0 mm

K 5.0 mm

Body, center

2006 Audi TT

Accessories and Body, Cab Body Collision Repair

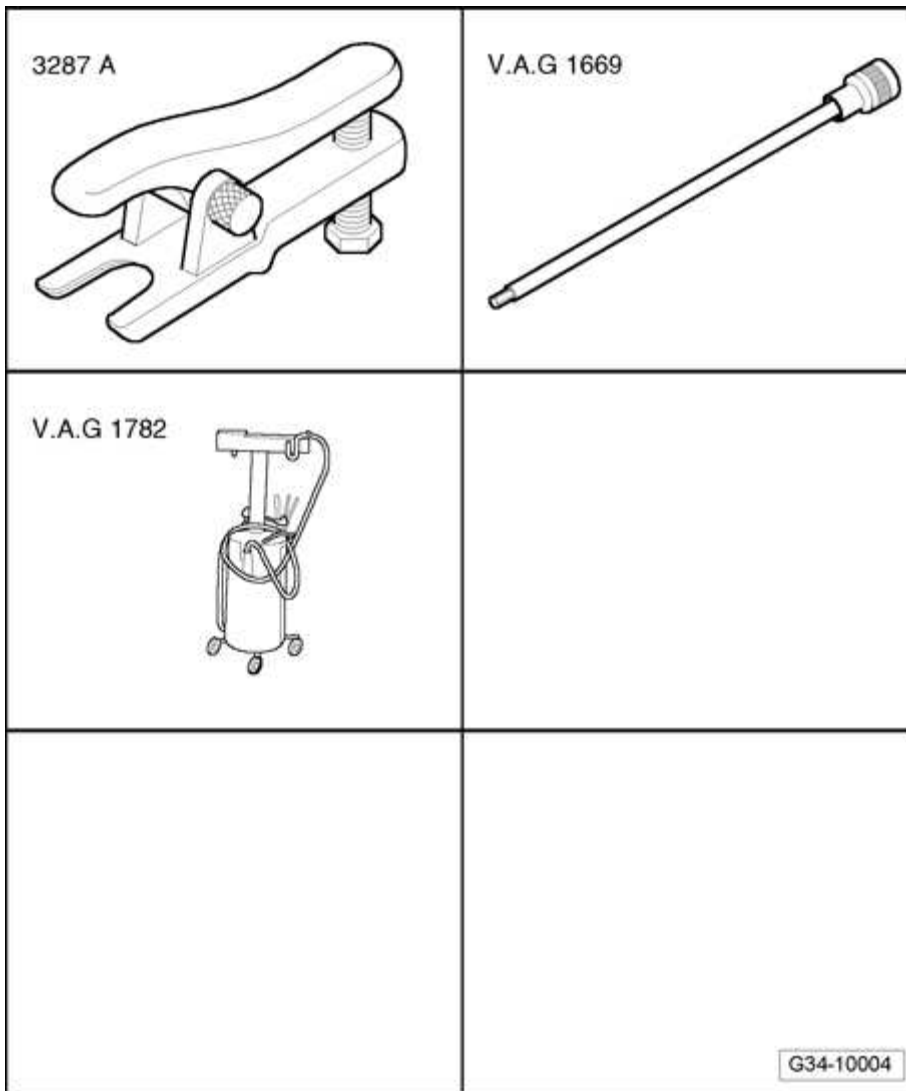

Fig. 15: Body Panel Gaps - Body, Center
Courtesy of VOLKSWAGEN UNITED STATES, INC.

A 1.0 mm

D 2.0 mm

G 3.5 mm

H 4.0 mm

J 4.5 mm

Body, rear

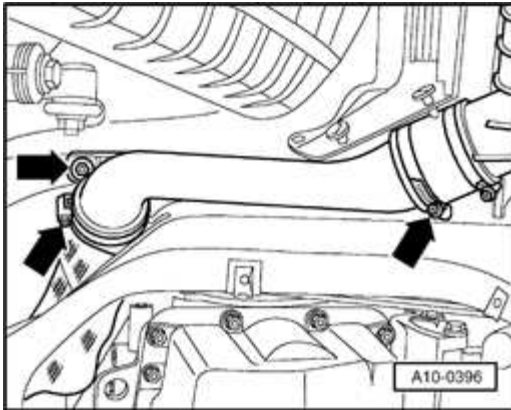

Fig. 16: Body Panel Gaps - Body, Rear
Courtesy of VOLKSWAGEN UNITED STATES, INC.

C 1.5 mm

D 2.0 mm

E 2.5 mm

F 3.0 mm

G 3.5 mm

J 4.5 mm

K 5.0 mm

Body (Roadster)

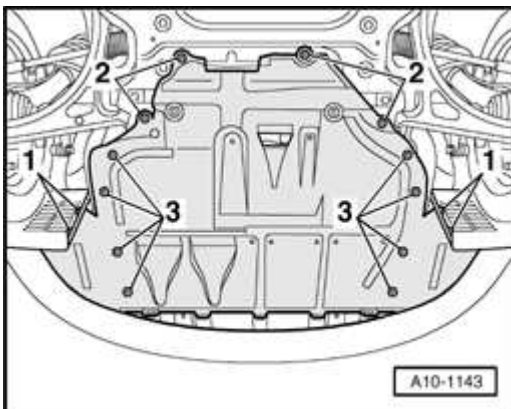

Fig. 17: Body Panel Gaps - Body (Roadster)

Courtesy of VOLKSWAGEN UNITED STATES, INC.

N - 0.0 mm

D 2.0 mm

E 2.5 mm

F 3.0 mm

G 3.5 mm

H 4.0 mm

M 6.0 mm (only for hardtop)

K 5.0 mm

O 8.0 mm

CORROSION PROTECTION MEASURES

Corrosion protection measures

The body is made from sheet metal panels that are zinc-coated (galvanized) on both sides.

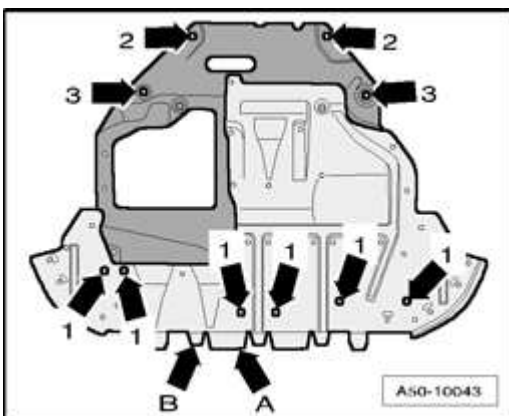

Fig. 18: Corrosion Protection Measures

Courtesy of VOLKSWAGEN UNITED STATES, INC.

Certain areas are cavity-treated and have to be re-sealed after repair work has been carried out.

FOAM-FILLED CAVITIES

Foam-filled cavities

The following areas of the body are foam-filled for acoustic reasons:

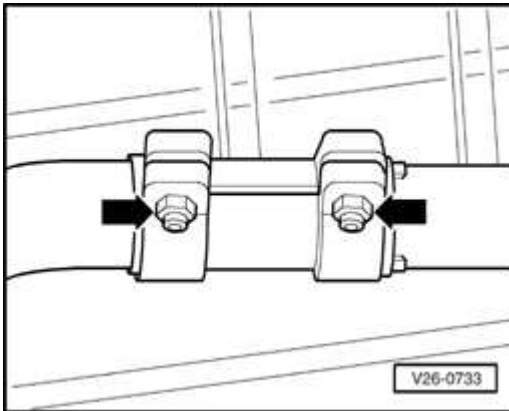

Fig. 19: Foam-Filled Cavities

Courtesy of VOLKSWAGEN UNITED STATES, INC.

A-pillar

a = Foam-filling hole

b = Foam-filling hole

ALUMINUM PANELS

Aluminum panels

Aluminum panels are installed in the following body areas:

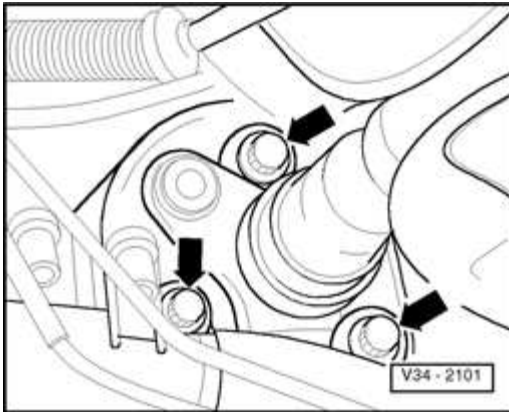

Fig. 20: Aluminum Panels

Courtesy of VOLKSWAGEN UNITED STATES, INC.

Hood

REINFORCED (HIGH-STRENGTH) BODY PANELS

Reinforced (high-strength) body panels

Reinforced (high-strength) panels are installed in the following body areas:

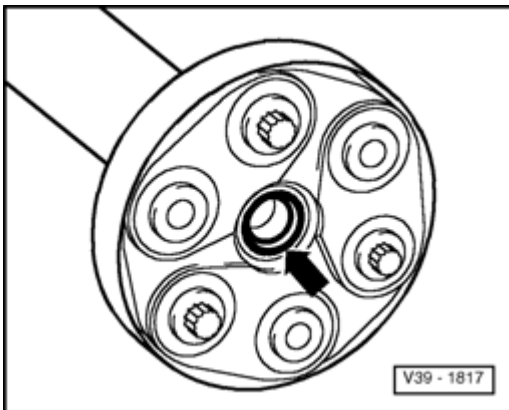

Fig. 21: Reinforced (High-Strength) Body Panels

Courtesy of VOLKSWAGEN UNITED STATES, INC.

Roof and reinforcements of sidewall frame, A-pillar hinge and seat belt guide console.

BONDED JOINTS

Bonded joints

The Audi TT body has bonded and spot-welded bonded joints which increases the vehicles rigidity and strength.

Bonded joints

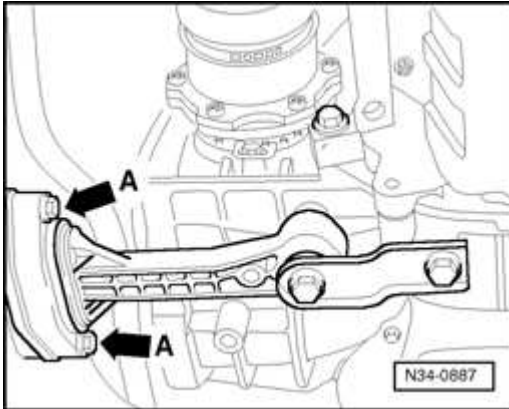

Fig. 22: Bonded Joints

Courtesy of VOLKSWAGEN UNITED STATES, INC.

For bonded joints, the sheet metal pieces are connected only with adhesive.

Spot welded bonded joints

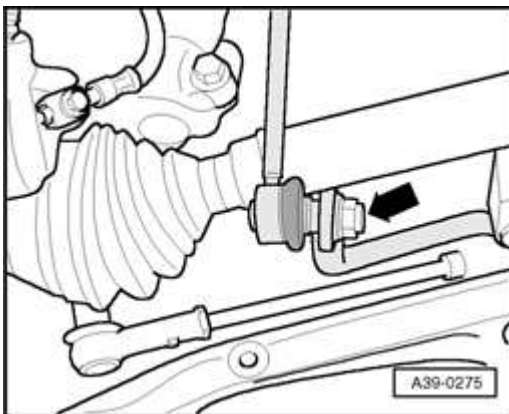

Fig. 23: Spot Welded Bonded Joints

Courtesy of VOLKSWAGEN UNITED STATES, INC.

In spot welded bonded joints, an electrically conductive adhesive is used between the panels which allows good root penetration for spot welding.

For spot weld bonding operations the welding current must not be increased. The pre-pressing time must be extended to about 30-50 cycles because of the

displacement of the adhesive. The resulting gasses must be extracted with a fume extractor.

Spot weld bonding is not carried out in the service sector.

Bonded joints, inspecting and repairing

Particular attention should be paid to these areas when diagnosing accident damage and carrying out body repairs.

The following points must be noted:

Do not use a chisel to test the strength of a joint or attempt to relieve stresses by hammering otherwise this will destroy the bonded joint.

These joints should be inspected particularly closely when diagnosing accident damage and after carrying out straightening work on the body.

If the area is not accessible with pop rivets, it must be repaired with an arc-welded seam (SG). If welding is used to repair the joint, the entire area must be re-welded since the heat produced by welding destroys the adhesive in the bonded joint. SG plug weld seams must be worked from thinner to thicker sheet metal. The resulting gasses must be extracted with a fume extractor.

Repair methods for replacing body parts

When making repairs, welded joints can be used in place of all spot welded bonded joints and certain bonded joints if no suitable body adhesive is available.

Do not make the repair with only the same spot welds or seams as originally used in production as these alone are not adequate.

The repair methods are presented in detail in the sections which follow.

NOTE:

- **If the instruction calls for additional spot welds, these should be applied in a single operation.**
- **Do not place new spot welds between original spot welds.**

- **SG plug welding should not be carried out until after spot welding.**
- **This avoids any increased shunt current when spot welding.**

Ensure good root penetration at all joints.

Seal off repaired joint flanges and apply cavity sealing where necessary.

Body, front

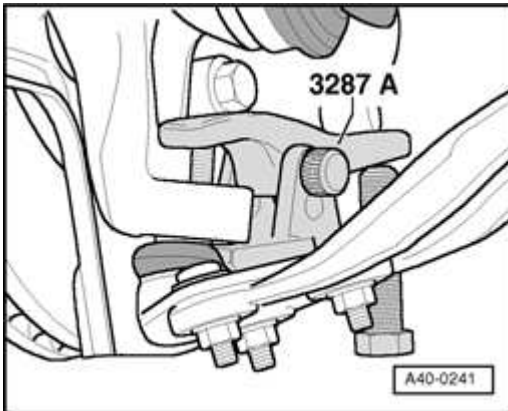

Fig. 24: Bonded Joints - Body, Front
Courtesy of VOLKSWAGEN UNITED STATES, INC.

- A = Inner A-pillar with outside sidewall frame. Additional 4 x SG plug weld seam to flange.

Body, center

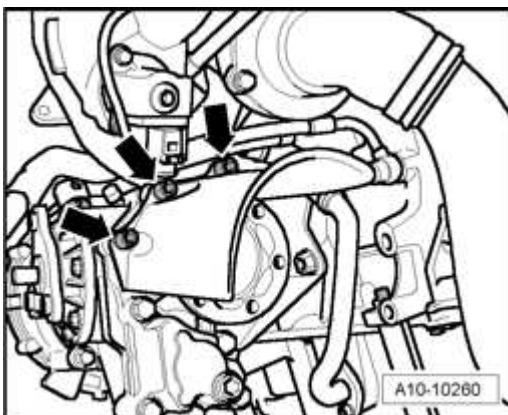

Fig. 25: Bonded Joints - Body, Center (1 Of 6)
Courtesy of VOLKSWAGEN UNITED STATES, INC.

- 1 = Front outside sidewall frame to inner upper A-pillar. SG continuous seam in recesses in place of bonded joint.
- 2 = Rear inside sidewall frame to reinforced hinge at bottom of trunk lid 2 x 10 mm SG seam at flange
- 3 = Roof to outer sidewall frame (inside) as original joint. Apply body adhesive and spot weld, but do not apply adhesive 15 mm to either side of spot welds.
- 4 = Rear inner sidewall frame to front outer sidewall frame. SG continuous seam in recesses in place of bonded joint.
- 5 = Front floor to frame mounting plate. In place of bonded joint make 4 x 20 mm, SG continuous seam.

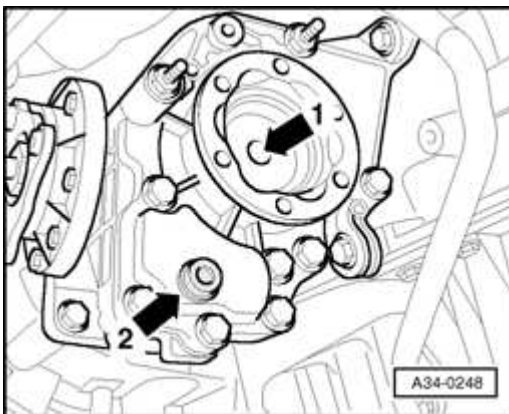

Fig. 26: Bonded Joints - Body, Center (2 Of 6)
Courtesy of VOLKSWAGEN UNITED STATES, INC.

- 6 = Front floor to frame mounting plate. In place of bonded joint at notches, make SG continuous seam.
- 7 = Front outside sidewall frame to inner A-pillar. In place of bonded joint at notches, make SG continuous seam.
- 8 = Outer side to side member. In place of bonded joint make 4 x 20 mm, SG continuous seam.

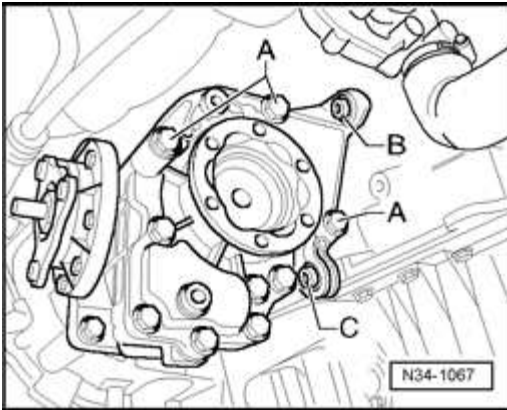

Fig. 27: Bonded Joints - Body, Center (3 Of 6)
 Courtesy of VOLKSWAGEN UNITED STATES, INC.

- 9 = Outer side to side member. In place of bonded joint, make additional 8 x SG plug weld seam.
- 10 = Outer rear wheelhousing to side member. In place of bonded joint, double the welding spots in addition.
- 11 = Side member connecting piece to side member. In place of bonded joint, double the welding spots in addition.
- 12 = Outside sidewall frame to outer side. In place of bonded joint, double the welding spots in addition.
- 13 = Roof to rear roof frame, in place of 3 x plugs, SG weld seam.

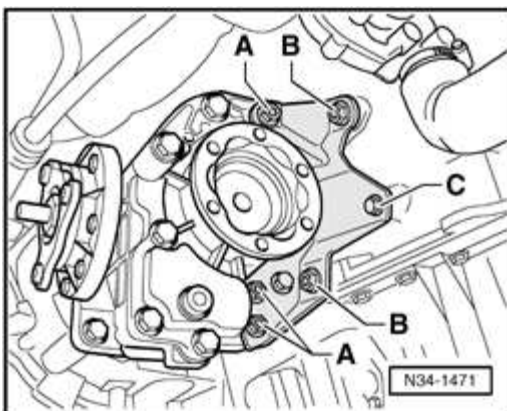

Fig. 28: Bonded Joints - Body, Center (4 Of 6)
 Courtesy of VOLKSWAGEN UNITED STATES, INC.

- 14 = Roof to outer sidewall frame (inside) as original joint. Apply body

adhesive and spot-weld, but do not apply adhesive 15 mm to either side of welding points.

- 15 = Hinge reinforcement bottom to top. In place of bonded joint, make 3 x SG plug weld seam.
- 16 = Hinge reinforcement to sidewall frame, instead of bonded joint make 3 x plug weld seam.
- 17 = Hinge reinforcement to roof frame, instead of bonded joint make 3 x plug weld seam.
- 18 = Roof to rear roof frame connection as original joint. Insert butyl tape and set roof in place.
- 19 = Roof with rear roof frame connection as original. Insert butyl tape and set roof in place.
- 20 = Apply floor locking piece side member at sidewall frame connection using original chassis adhesive and spot weld, but do not apply adhesive 15 mm to either side of spot-welding points.

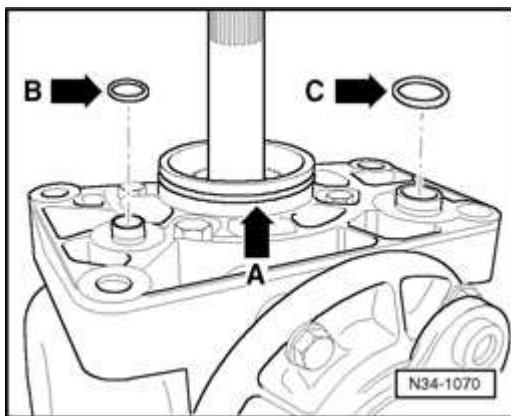

Fig. 29: Bonded Joints - Body, Center (5 Of 6)

Courtesy of VOLKSWAGEN UNITED STATES, INC.

- 21 = Rear floor rear section to rear longmember wheelhousing. In place of bonded joint, make 2 x 20 mm SG continuous seam.
- 22 = Rear floor to reinforcement tie-down eyelet. In place of bonded joint make 2 x 20 mm SG continuous seam.
- 23 = Rear section of rear floor to reinforcement rear cross panel In place of bonded joint, make 3 x 20 mm SG continuous seam.

- 24 = Floor crossmember to rear floor. In place of bonded joint, make 4 x 20 mm SG continuous seam.
- 25 = Front section of rear floor / rear section of rear floor with longmember at rear wheelhousing. In place of bonded joint, make 6 x 20 mm SG continuous seam.
- 26 = Outer side to outside sidewall frame. In place of bonded joint, double the weld spots in addition.

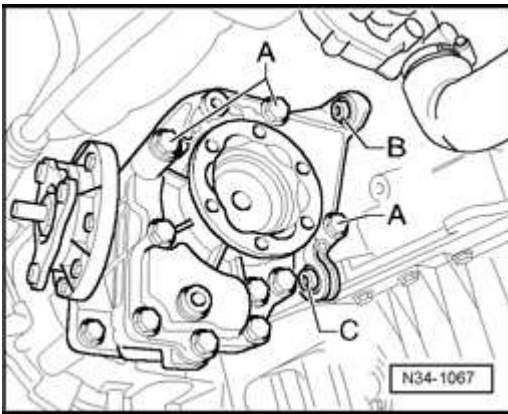

Fig. 30: Bonded Joints - Body, Center (6 Of 6)
Courtesy of VOLKSWAGEN UNITED STATES, INC.

- 27 = Sheet metal piece to inner sidewall frame. In place of bonded joint make additional 2 x RP spot weld seam.
- 28 = Outer side to outside sidewall frame. In place of bonded joint make additional 8 x RP spot weld seam.
- 29 = Rear inner sidewall frame to rear outer sidewall frame. In place of bonded joint at notches, make SG continuous seam.

Body, center (Roadster)

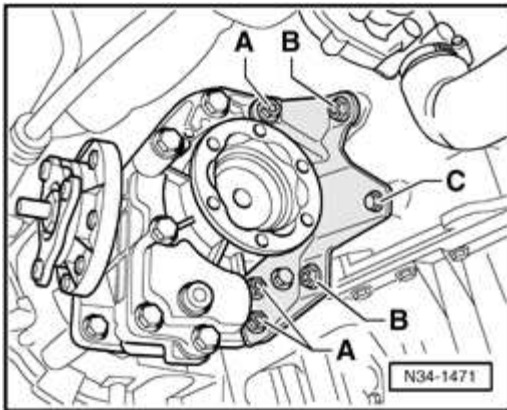

Fig. 31: Bonded Joints - Body, Center (Roadster) (1 Of 2)
 Courtesy of VOLKSWAGEN UNITED STATES, INC.

- 30 = longmember to front floor. In place of bonded joint, make 4 x 20 mm SG continuous seam.
- 31 = Outer side to side member. In place of bonded joint, make 4 x 20 mm SG continuous seam.

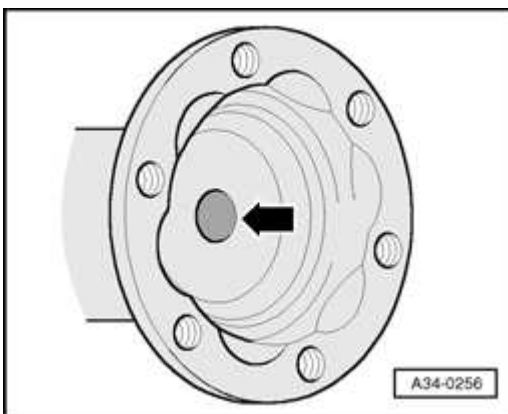

Fig. 32: Bonded Joints - Body, Center (Roadster) (2 Of 2)
 Courtesy of VOLKSWAGEN UNITED STATES, INC.

- 32 = Outer side to side member. In place of bonded joint, make additional 8 x SG plug weld seam.
- 33 = Outer rear wheelhousing to side member. In place of bonded joint, double the welding spots in addition.

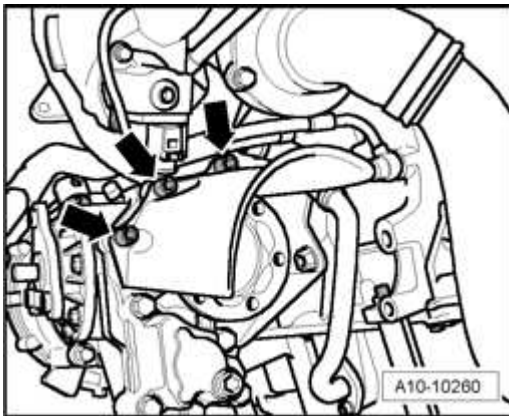

Fig. 33: Bonded Joints - Body, Rear (1 Of 2)

Courtesy of VOLKSWAGEN UNITED STATES, INC.

- A = As in original joint, apply adhesive and bead over edge of wheel housing. If the adhesive bond is damaged, re-work as follows:
- Brush area, restore paint structure and apply cavity sealing. If the adhesive bond is damaged over a length of more than 100 mm, make a 10 mm SG seam every 50 mm. Re-work wheel housing liner if necessary.
- B = Rear wheelhousing liner to rear wheel housing, make additional 4 x 30 mm SG seam.
- C = Rear wheelhousing liner to rear floor, RP spot weld seam with double the number of welds.
- D = Rear longmember to rear wheelhousing, RP spot weld seam with double the number of welds.
- E = Rear wheelhousing liner to rear wheelhousing RP spot weld seam with 25 mm spacing.
- F = Rear wheelhousing liner to rear wheelhousing, make 2 additional spot welds.
- G = Install replacement part taillight mount to rear cross panel. In place of bonded joint make 3 x SG plug weld seam.

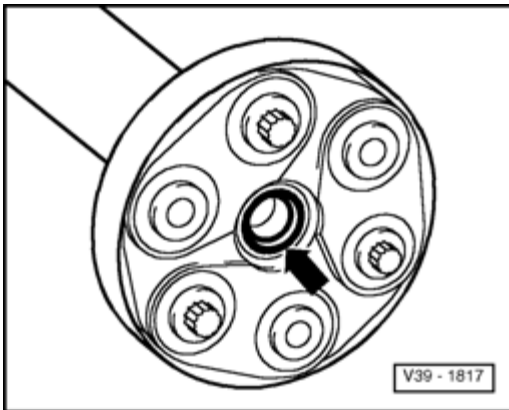

Fig. 34: Bonded Joints - Body, Rear (2 Of 2)
Courtesy of VOLKSWAGEN UNITED STATES, INC.

STRAIGHTENING JIG

Overview

NOTE:

- The item numbers in the illustrations are identical with the end numbers on the straightening jig mounts.
- The circled item numbers on the straightening jig mounts are for checking the body with or without mechanical units installed.
- Alignment brackets must be checked for freedom of movement before setting them on the straightening jig. Components that are in the way must be loosened or removed if necessary.
- The required basic set size is given for straightening jig mounts.

Alignment bracket set VAS 5020

Alignment bracket set VAS 5020/6

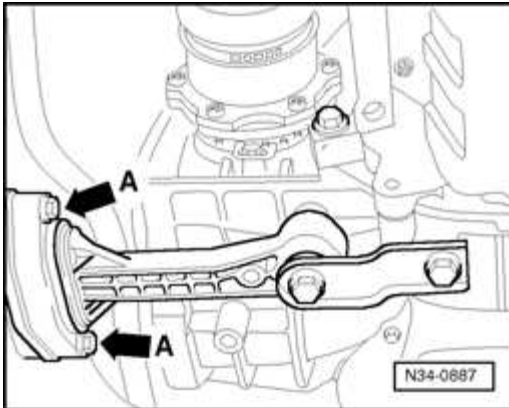

Fig. 35: Straightening Jig - Overview

Courtesy of VOLKSWAGEN UNITED STATES, INC.

2 - MZ 200 and TV 400

64 - MZ 200 and alignment bracket mount - 2 -

6 - MZ 142

8 - MZ 260

10 - MZ 200

13 - Centering piece, identical at left and right

14 - MZ 601

16 - Centering piece, identical at left and right

18 - MZ 140

-

26 - MZ 140

28 - MZ 080

30 - MZ 080 and mounting plate - 31 -

32 - MZ 602

30 - MZ 200

66 - Backing plate

34 - MZ 200

67 - Backing plate

Overview and allocation of MZ components

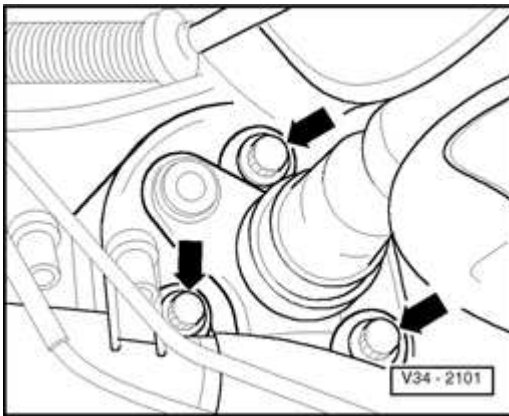

Fig. 36: Straightening Jig - Overview And Allocation Of MZ Components
Courtesy of VOLKSWAGEN UNITED STATES, INC.

2 - MZ 200 and TV 400

6 - MZ 142

8 - MZ 260

10 - MZ 200

14 - MZ 601

18 - MZ 140

24 - MZ 080

26 - MZ 140

2006 Audi TT

Accessories and Body, Cab Body Collision Repair

28 - MZ 080

30 - MZ 080

32 - MZ 602

34 - MZ 200

66 - Backing plate

67 - Backing plate

Overview of the alignment bracket position with MZ-components for vehicles with mechanical components installed

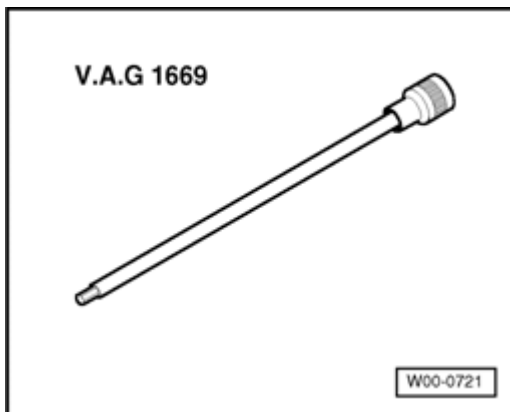

Fig. 37: Straightening Jig - Overview Of The Alignment Bracket Position With MZ-Components For Vehicles With Mechanical Components Installed
Courtesy of VOLKSWAGEN UNITED STATES, INC.

6 - MZ 142

12 - MZ 080

18 - MZ 080

19 - Centering piece, identical at left and right

26 - MZ 140

28 - MZ 080

30 - MZ 080

34 - MZ 200

66 - Backing plate.

67 - Backing plate.

Overview of front alignment bracket positions

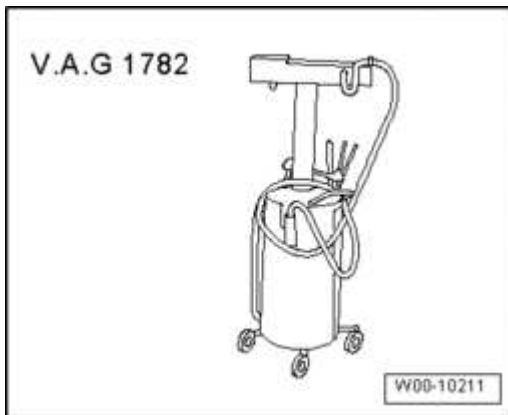

Fig. 38: Straightening Jig - Overview Of Front Alignment Bracket Positions
Courtesy of VOLKSWAGEN UNITED STATES, INC.

2 - Front longmember

When checking body, bolt on this MZ last, as the longitudinal position of the impact absorber mount can vary by several mm due to production tolerances if necessary do not bolt down.

64 - Front longmember / front end of wheel housing

Overview of front alignment bracket positions

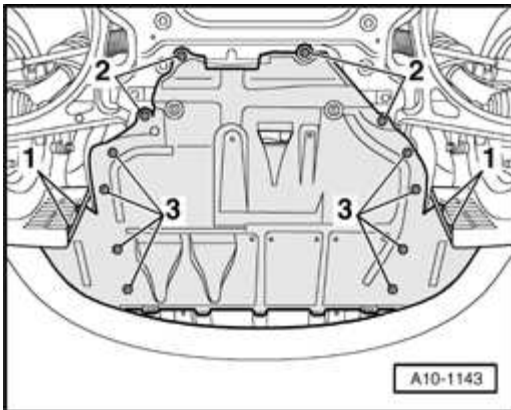

Fig. 39: Straightening Jig - Overview Of Front Alignment Bracket Positions
Courtesy of VOLKSWAGEN UNITED STATES, INC.

Overview of front alignment bracket positions

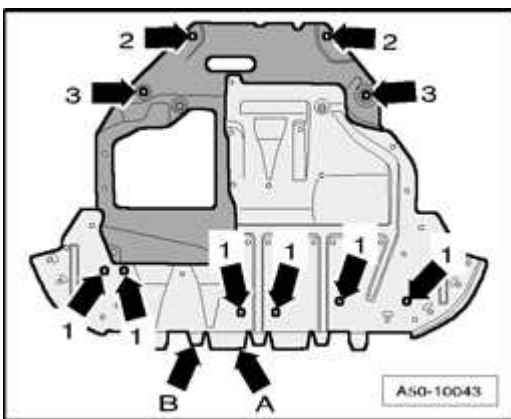

Fig. 40: Straightening Jig - Overview Of Front Alignment Bracket Positions
Courtesy of VOLKSWAGEN UNITED STATES, INC.

8 - Mount for engine support

9 - Mount for engine support

Overview of front alignment bracket positions